

SURFACE MOUNT SUPER FAST RECOVERY RECTIFIER

FEATURES

- For surface mounted applications
- Low profile package
- Glass Passivated Chip Junction
- Superfast reverse recovery time
- Lead free in comply with EU RoHS 2011/65/EU directives

MECHANICAL DATA

- Case: SMBF
- Terminals: Solderable per MIL-STD-750, Method 2026
- Approx. Weight: 57mg / 0.002oz

PINNING

PIN	DESCRIPTION
1	Cathode
2	Anode

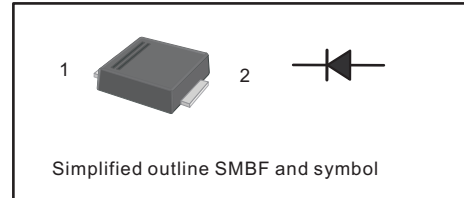

ABSOLUTE MAXIMUM RATINGS AND CHARACTERISTICS

Ratings at 25 °C ambient temperature unless otherwise specified. Single phase, half wave, 60 Hz, resistive or inductive load. For capacitive load, derate current by 20%.

Parameter	Symbols	ES3ABF	ES3BBF	ES3CBF	ES3DBF	ES3EBF	ES3GBF	ES3JBF	Units
Maximum Repetitive Peak Reverse Voltage	V_{RRM}	50	100	150	200	300	400	600	V
Maximum RMS voltage	V_{RMS}	35	70	105	140	210	280	420	V
Maximum DC Blocking Voltage	V_{DC}	50	100	150	200	300	400	600	V
Maximum Average Forward Rectified Current at $T_L = 100\text{ }^\circ\text{C}$	$I_{F(AV)}$	3							A
Peak Forward Surge Current 8.3 ms Single Half Sine Wave Superimposed on Rated Load (JEDEC Method)	I_{FSM}	100							A
Maximum Forward Voltage at 3A	V_F	1				1.25		1.68	V
Maximum DC Reverse Current at Rated DC Blocking Voltage $T_a = 25\text{ }^\circ\text{C}$ $T_a = 125\text{ }^\circ\text{C}$	I_R					5 100			μA
Typical Junction Capacitance	C_j					45			pF
Maximum Reverse Recovery Time at $I_F=0.5\text{A}$, $I_R=1\text{A}$, $I_{rr}=0.25\text{A}$	t_{rr}					35			ns
Typical Thermal Resistance ²⁾	$R_{\theta JA}$					55			$^\circ\text{C/W}$
Operating and Storage Temperature Range	T_j, T_{stg}					-55 ~ +150			$^\circ\text{C}$

Note :

1. Measured with $I_F = 0.5\text{ A}$, $I_R = 1\text{ A}$, $I_{rr} = 0.25\text{ A}$
2. P.C.B. mounted with 0.5 X 0.5" (12.7 X 12.7 mm) copper pad areas.

SURFACE MOUNT SUPER FAST RECOVERY RECTIFIER

Fig.1 Reverse Recovery Time Characteristic And Test Circuit Diagram

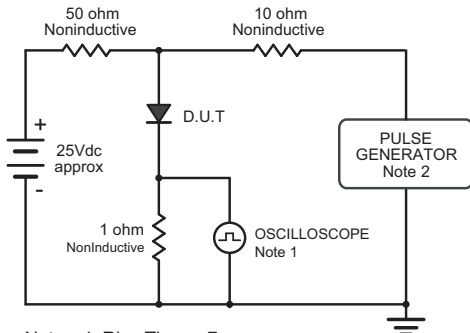

Note: 1. Rise Time = 7ns, max.
Input Impedance = 1megohm, 22pF.
2. Rise Time = 10ns, max.
Source Impedance = 50 ohms.

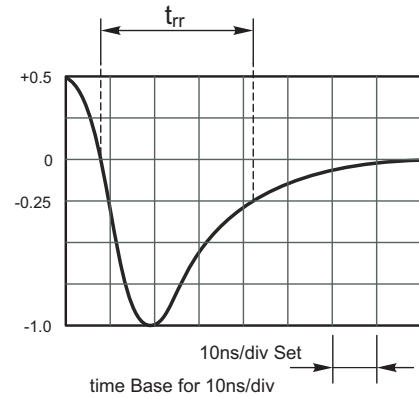

Fig.2 Maximum Average Forward Current Rating

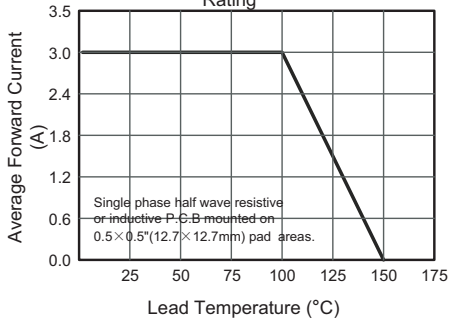

Fig.3 Typical Reverse Characteristics

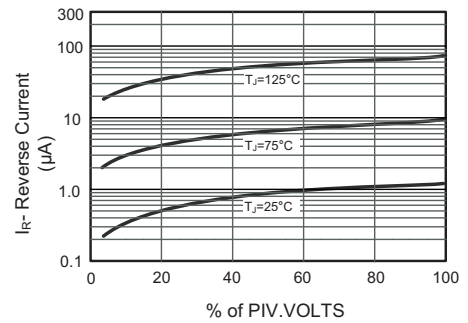

Fig.4 Typical Forward Characteristics

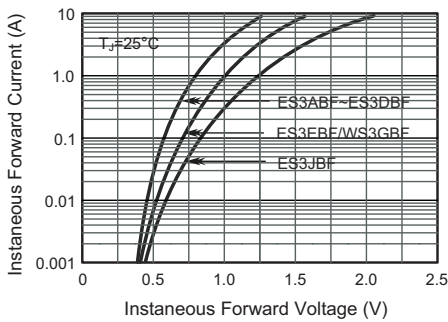

Fig.5 Typical Junction Capacitance

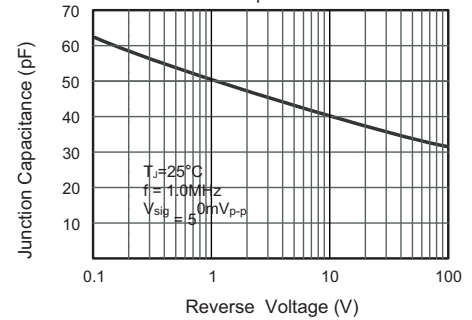
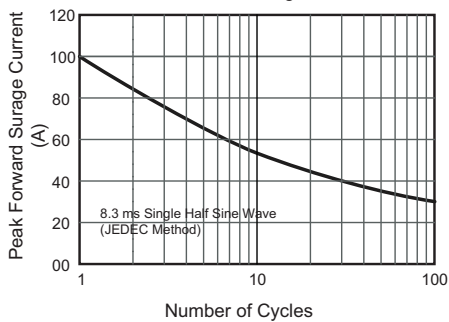

Fig.6 Maximum Non-Repetitive Peak Forward Surge Current



SURFACE MOUNT SUPER FAST RECOVERY RECTIFIER

PACKAGE OUTLINE

Plastic surface mounted package; 2 leads

SMBF

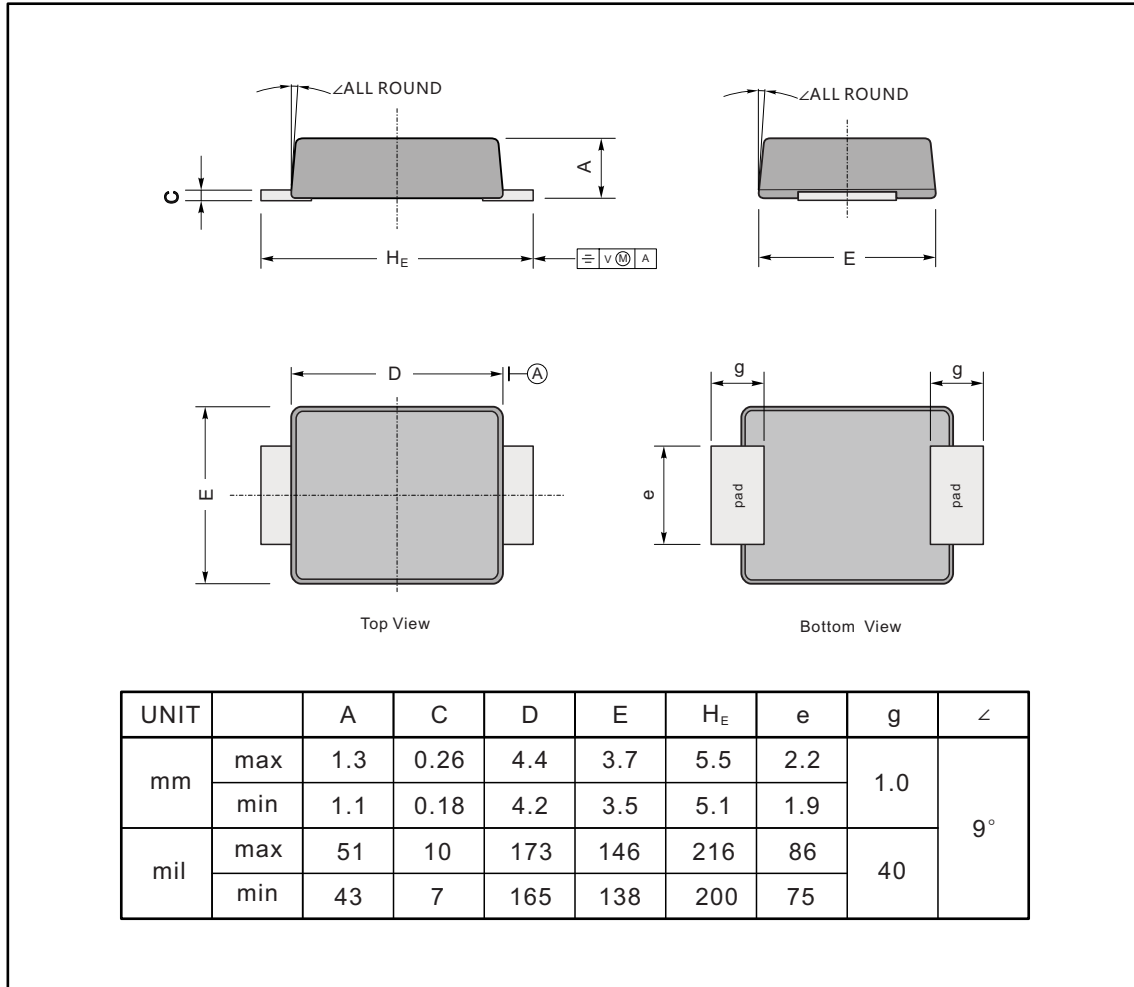

The recommended mounting pad size

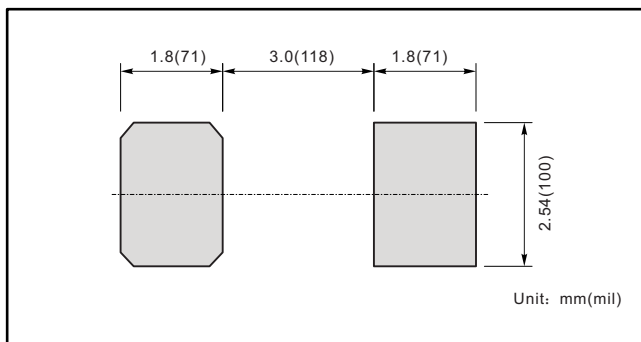

Marking

Type number	Marking code
ES3ABF	E3AB
ES3BBF	E3BB
ES3CBF	E3CB
ES3DBF	E3DB
ES3EBF	E3EB
ES3GBF	E3GB
ES3JBF	E3JB

Disclaimer

All product, product specifications and data are subject to change without notice to improve reliability, function or design or otherwise.