



DESCRIPTION

The ES4810SAA Digital Audio Processor (DAP™3) is an SOC chip designed for automotive audio applications. It integrates a servo controller, RF amplifier, servo DSP, MP3 and WMA decoders, USB 2.0 Driver, 2 channels audio DAC, 2 channels of audio ADC for Karaoke, SD/MS/MMC card reader and MP3 encoder. The ES4810 has the largest feature set and is the most highly integrated and cost-effective solution currently available.

The ES4810 provides auxiliary control pins for AM/FM tuner control, LCD driver and system management. The ES4810's internal RISC processor can be used in place of a microcontroller to provide all system controls and user interface.

The ES4810 digital audio processor is available in a 208-pin Low-profile Quad Flat Pack (LQFP) package with lead-free leads. The silicon is qualified for an extended temperature range of -40 to 85 °C for automotive applications.

FEATURES

- CD Optical loader with integrated servo controller and RF amplifier.
- Disc format supports CD-R/RW, CD.
- File system supports ISO9660, UDF, NTFS, and FAT32.
- Audio DSP decodes MP3, WMA, AAC, and OGG. Can also encode MP3 and store into USB flash or memory cards.
- USB 2.0 FS to support USB flash drive for music playback.
- Digital audio SPDIF In and Out.
- VDAC for file browsing and management.
- 2-channel audio DAC, 2-channel ADC.
- 2-channel PWM supports class D digital amplifiers.
- SD/MMC/MS card reader interface.
- Audio equalizer and bass enhancements support.
- LCD panel control and FM/AM tuner control.
- Serial UART port.
- 1.5V power supply with 3.3V tolerant I/Os, power consumption < 1W.
- Lead-free leads.

SYSTEM BLOCK DIAGRAM

A sample system block diagram for the ES4810 digital audio board design is shown in Figure 1.

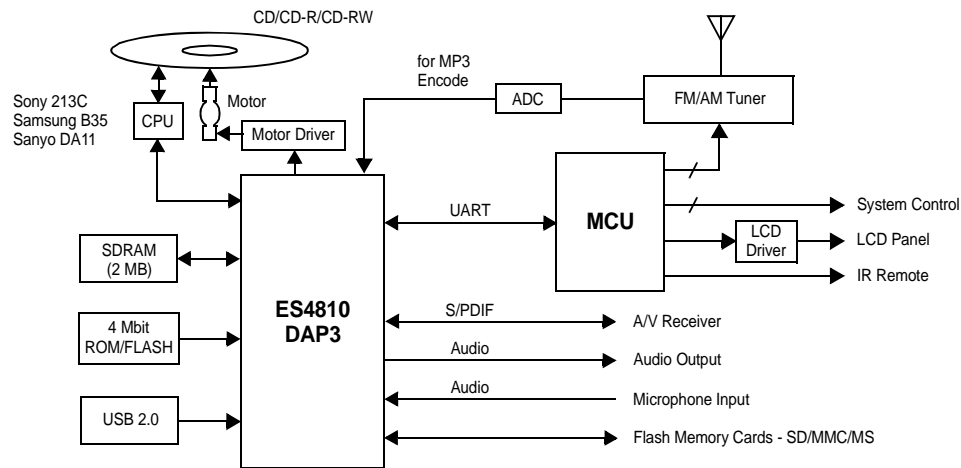
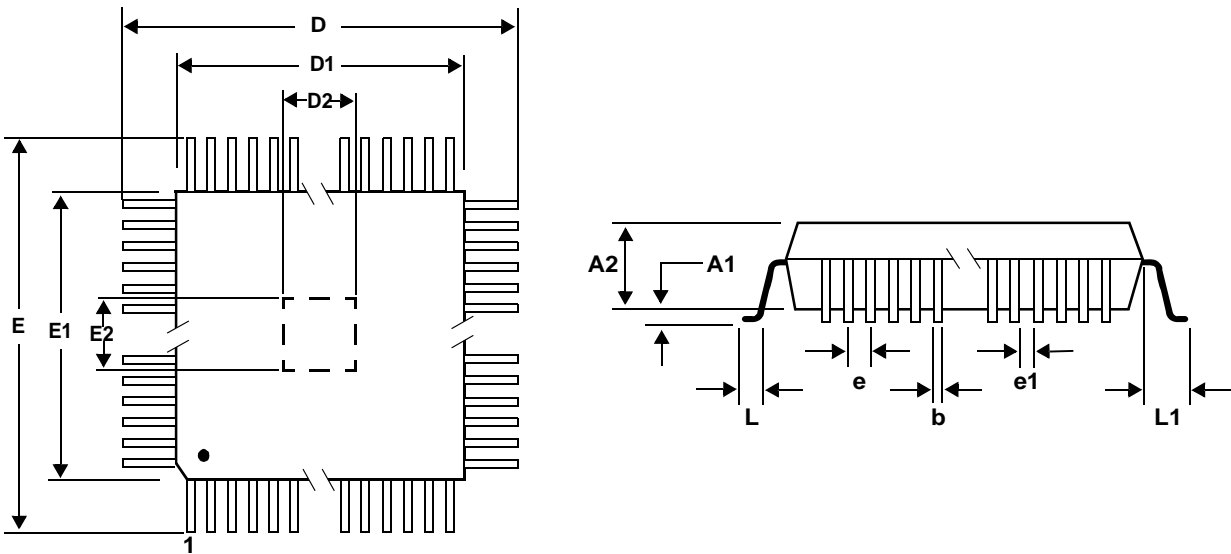

Figure 1 ES4810 System Block Diagram

MECHANICAL DIMENSIONS

The mechanical dimensions for the ES4810 are shown in Figure 2.



Symbol	Descriptions	Millimeters		
		Minimum	Nominal	Maximum
D	Lead to lead, X-axis	29.85	30.00	30.15
D1	Package's outside, X-axis	27.90	28.00	28.10
D2	Exposed pad, X-axis	—	7.0 ⁽¹⁾	—
E	Lead to lead, Y-axis	29.85	30.00	30.15
E1	Package's outside, Y-axis	27.90	28.00	28.10
E2	Exposed pad, Y-axis	—	7.0 ⁽¹⁾	—
A1	Board standoff	0.05	0.10	0.15
A2	Package thickness	1.35	1.40	1.45
b	Lead width	0.17	0.22	0.27
e	Lead pitch (center to center)	—	0.50	—
e1	Lead gap	0.23	0.28	0.33
L	Foot length	0.45	0.60	0.75
L1	Lead length	0.90	1.00	1.10
—	Foot angle	0°	—	7°
—	Coplanarity	—	—	0.102
—	Number of leads in X-axis	—	52	—
—	Number of leads in Y-axis	—	52	—
—	Total number of leads	—	208	—
—	Package type	—	LQFP	—

⁽¹⁾ Depending on the assembly house, the D2 and E2 dimensions may vary slightly.

For lead-free devices, the solder paste and PCB finish/plating must be 100% lead free in order to ensure proper solderability.

Figure 2 208-pin Low-profile Quad Flat Package (LQFP)

P C BOARD LAYOUT CONSIDERATIONS

Required Printed Circuit Board Layout

The ES4810 LQFP package requires additional heat sinking to prevent heat-caused damage to the chip. To accomplish this heat dissipation in an economical manner, the following printed circuit board (PCB) layout is required.

The land pattern for the chips still use the standard 208-pin LQFP footprint on the PCB with the addition of the heat sink, as shown in Figure 3. Required for heat dissipation is the addition of a solid copper fill on the top and bottom layers of the PCB, along with 1mm square solder mask exposures and via in the center of each exposure.

The metal land on the underside of the IC must have more than 90% of its surface area directly soldered onto the PCB (i.e., the solder mask openings as shown below) for the heat dissipation to be effective.

It is not recommended to route any traces between the land pattern and metal land.

The specifications for the LQFP heat sinking is listed in Table 1

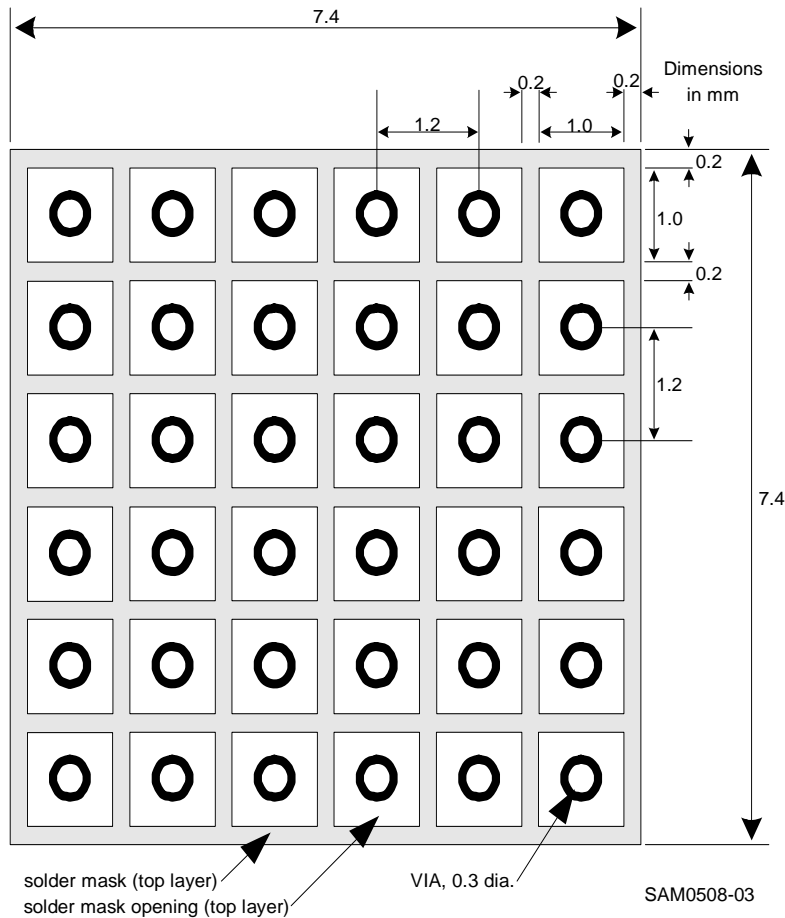

Figure 3 Required PCB Layout for Heat Dissipation

Table 1 LQFP Heat Sink Specifications

Parameters	Dimensions	Parameters	Dimensions
PCB Layers	4, minimum	Via diameter	0.3 mm
Solder mask opening (top layer)	1.0 × 1.0 mm	Via spacing (center to center)	1.2 mm
Solder mask width	0.2 mm	Via plating	must be plugged

ORDERING INFORMATION

Part Number	Description	Package
ES4810SAA	Digital Audio Processor with extended temperature range for automotive applications	208-pin LQFP
ES4810FAA	Digital Audio Processor	208-pin PQFP

The first letter F in the part number identifies the package type PQFP.

The first letter S in the part number identifies the package type LQFP.



ESS Technology, Inc.
48401 Fremont Blvd.
Fremont, CA 94538
Tel: (510) 492-1088
Fax: (510) 492-1898

No part of this publication may be reproduced, stored in a retrieval system, transmitted, or translated in any form or by any means, electronic, mechanical, manual, optical, or otherwise, without the prior written permission of ESS Technology, Inc.

ESS Technology, Inc. makes no representations or warranties regarding the content of this document.

All specifications are subject to change without prior notice.

ESS Technology, Inc. assumes no responsibility for any errors contained herein.

U.S. patents pending.

MPEG is the Moving Picture Experts Group of the ISO/IEC. References to MPEG in this document refer to the ISO/IEC JTC1 SC29 committee draft ISO 11172 dated January 9, 1992.

Vibratto, SmartBright, SmartLogo, SmartColor, and Music Slideshow are trademarks of ESS Technology, Inc.

Dolby is a trademark of Dolby Laboratories, Inc.

Trusurround, Trusurround XT, SRS, and (o) symbol are trademarks of SRS Labs., Inc.

All other trademarks are trademarks of their respective companies and are used for identification purposes only.