



## 12-pin, 24-Bit Stereo D/A Converter for PCM Audio

### GENERAL DESCRIPTION

The ES7149 is a low cost 12-pin stereo digital to analog converter. The ES7149 can accept I<sup>2</sup>S serial audio data format up to 24-bit word length. The device uses advanced multi-bit  $\Delta$ - $\Sigma$  modulation technique to convert data into two channel analog outputs. The multi-bit  $\Delta$ - $\Sigma$  modulator makes the device with very low sensitivity to clock jitter and very low out of band noise.

### FEATURES

- 106 dB SNR
- -85 dB THD+N
- Up to 100 kHz sampling frequency
- Support USB clocks or non standard audio clocks like 25 MHz or 26 MHz
- I<sup>2</sup>S audio data format, 16-24 bits
- Single power supply 3V to 3.6V

### APPLICATIONS

- Digital Photo Frame
- Set top box
- Digital TV
- DVD player
- Audio player

### ORDERING INFORMATION

ES7149    -40°C ~ +85°C    QFN-12

### BLOCK DIAGRAM

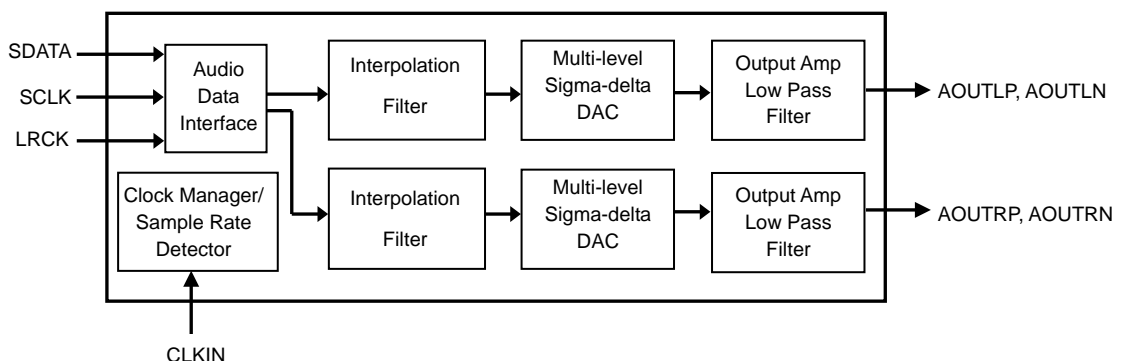

1. PIN DESCRIPTIONS

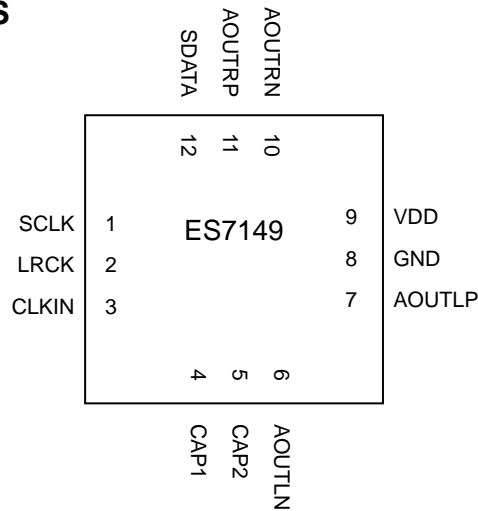

PIN	PIN	I/O	DESCRIPTION
1	SCLK	I	Bit clock input
2	LRCK	I	Left and right channel clock input indicating input data sampling rate (Fs) and channel selection
3	CLKIN	I	System clock input
4	CAP1	O	Filtering capacitor
5	CAP2	O	Filtering capacitor
6	AOUTLN	O	Analog N output of left channel
7	AOUTLP	O	Analog P output of left channel
8	GND	I	Ground
9	VDD	I	Device power supply
10	AOUTRN	O	Analog N output of right channel
11	AOUTRP	O	Analog P output of right channel
12	SDATA	I	Serial audio data input

2. RECOMMENDED APPLICATION CIRCUIT

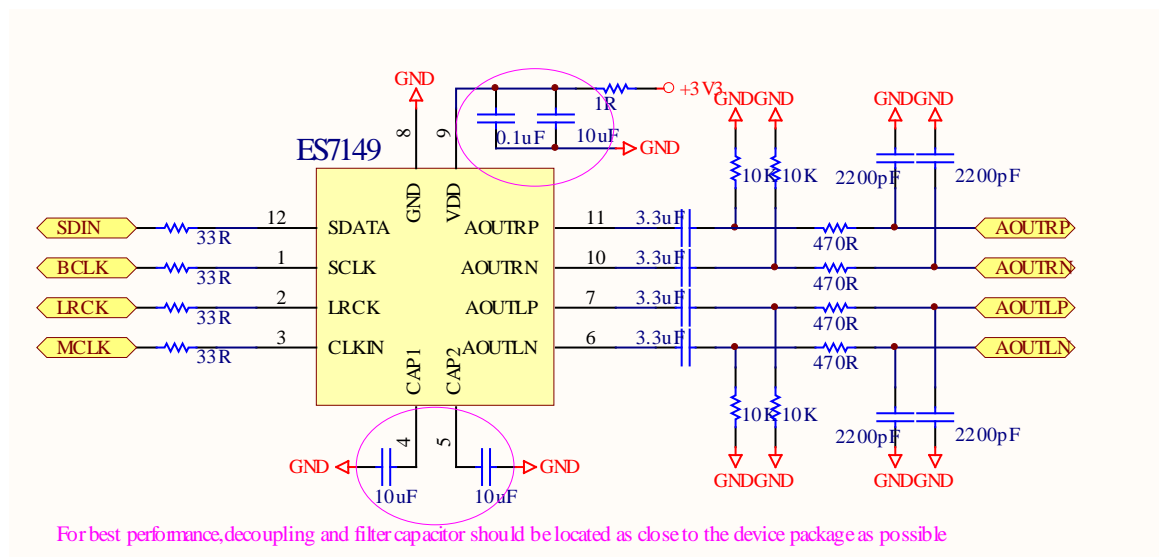

Figure 1 Recommended Application Circuit

### 3. APPLICATION DESCRIPTIONS

#### Sampling Rate and Input Clocks

According to the sampling rate, the device can work in two speed modes, single speed and double speed. Table 1 lists the typical clock modes supported by the device. The device supports USB clocks or non standard audio clocks like 25 MHz or 26 MHz.

**Table 1 Speed Mode and CLKIN/LRCK Ratio**

MODE	Sampling Rate	CLKIN/LRCK Ratio
Single Speed	8kHz – 50kHz	32, 64, 128, 192, 256, 384, 512, 768, 1024
Double Speed	84kHz – 100kHz	128, 192, 256, 384, 512, 768, 1024

#### Audio Data Input

The ES7149 can accept I<sup>2</sup>S serial audio input data from 16-bit to 24-bit. The device can detect the data word length automatically. The relationship of SDATA, SCLK and LRCK for the format is illustrated through Figures 2.

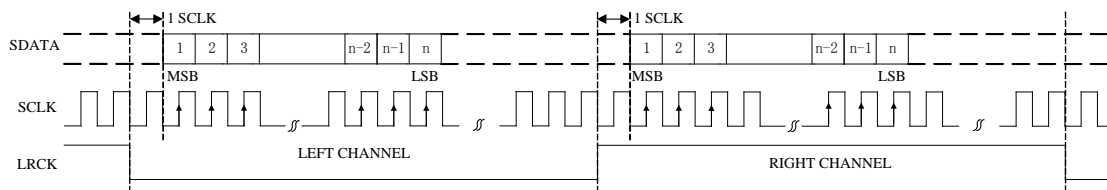

Figure 2 I<sup>2</sup>S serial audio data format up to 24-bit

#### Power Up and Power Down

Upon applying VDD, the device will reset itself and enter power down state. During this state, the device clamps outputs to ground and power down the device operation except for clock management unit. Once proper CLKIN and LRCK clocks are applied, the device will leave power down state, and the device outputs ramp from ground to common mode voltage softly. Then the device enters the normal operation.

## 4. ELECTRICAL CHARACTERISTICS

### Absolute Maximum Ratings

At or beyond this condition, operating continuously may cause permanent damage to the device. The performance and functions of the device are not guaranteed at these extremes.

PARAMETER	MIN	MAX
Supply Voltage Level	-0.3V	+5.0V
Input Voltage Range	GND-0.3V	VDD+0.3V
Operating Temperature Range	-40°C	+85°C
Storage Temperature	-65°C	+150°C

### Recommended Operating Conditions

PARAMETER	MIN	TYP	MAX	UNIT
Supply Voltage Level	3	3.3	3.6	V

### Analog Characteristics

Test conditions: VDD=3.3V, GND=0V, ambient temperature=25°C, Fs=48KHz, CLKIN/LRCK=256, input 0dB 1KHz sinewave

PARAMETER	MIN	TYP	MAX	UNIT
<b>DAC Performance</b>				
Signal to Noise Ratio (Note 1)	95	106		dB
THD+N		-85	-80	dB
Channel Separation (1KHz)		100		dB
Dynamic Range		106		dB
Interchannel Gain Mismatch		0		dB
Frequency Response (20Hz-20KHz)	-0.02		+0.08	dB
<b>Filter Frequency Response characteristics</b>				
<b>Single Speed</b>				
Passband	0		0.454	Fs
Stopband	0.547			Fs
Passband Ripple		±0.05		dB
Stopband Attenuation	-53			dB
<b>Double Speed</b>				
Passband	0		0.417	Fs
Stopband	0.583			Fs
Passband Ripple		±0.005		dB

Stopband Attenuation	-56			dB
<b>Quad Speed</b>				
Passband	0		0.2083	Fs
Stopband	0.792			Fs
Passband Ripple		$\pm 0.006$		dB
Stopband Attenuation	-50			dB
<b>Analog Output Characteristics</b>				
Full Scale Output Level		$0.7 \cdot V_{DD}$		Vpp
Output Impedance		120		$\Omega$
Minimum Load Resistance		2		K $\Omega$
Maximum Capacitance		100		pF

Note 1. A-weighted filter is used in measurement.

## Serial Audio Port Switching Characteristics

PARAMETER	SYMBOL	MIN	MAX	UNIT
CLKIN Frequency			51.2	MHz
CLKIN Duty Cycle		40	60	%
LRCK Frequency			200	KHz
LRCK Duty Cycle		40	60	%
SCLK Frequency			26	MHz
SCLK Pulse Width Low	$T_{SCKL}$	15		ns
SCLK Pulse Width High	$T_{SCKH}$	15		ns
SCLK Rising to LRCK Edge Delay	$T_{LRH}$	10		ns
SCLK Rising to LRCK Edge Setup Time	$T_{RSU}$	10		ns
SDATA Valid to SCLK Rising Setup Time	$T_{SDS}$	10		ns
SCLK Rising to SDATA Hold Time	$T_{SDH}$	10		ns

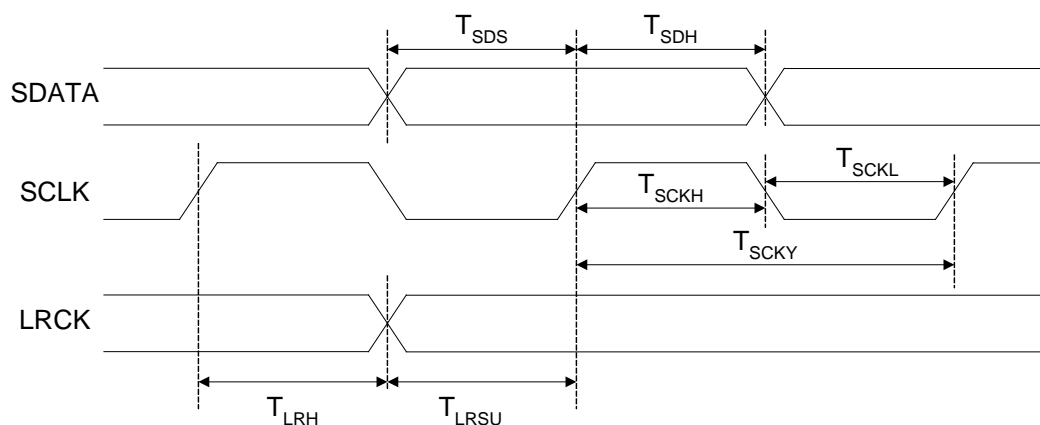
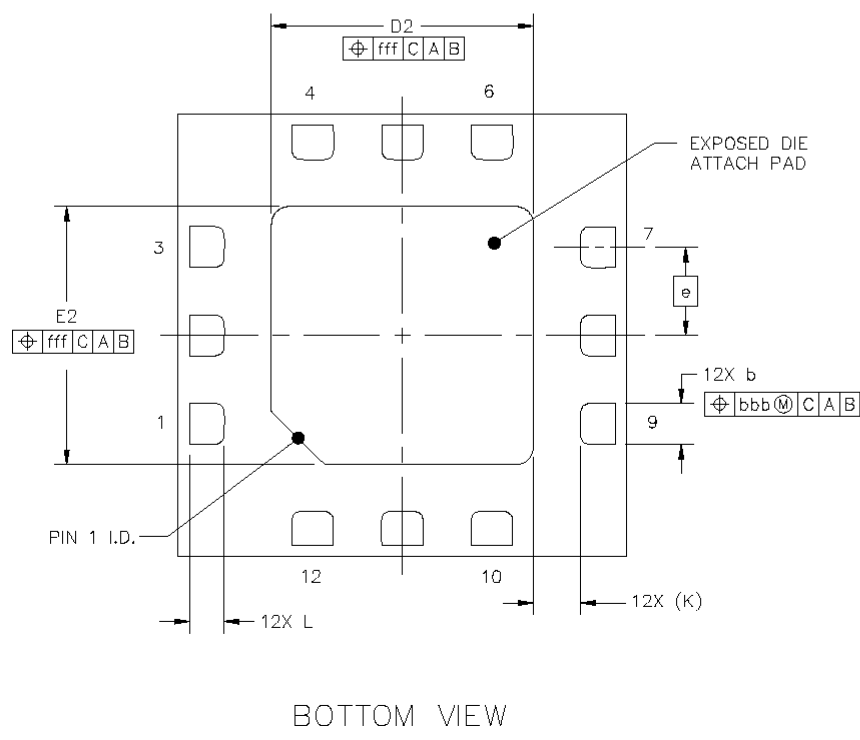
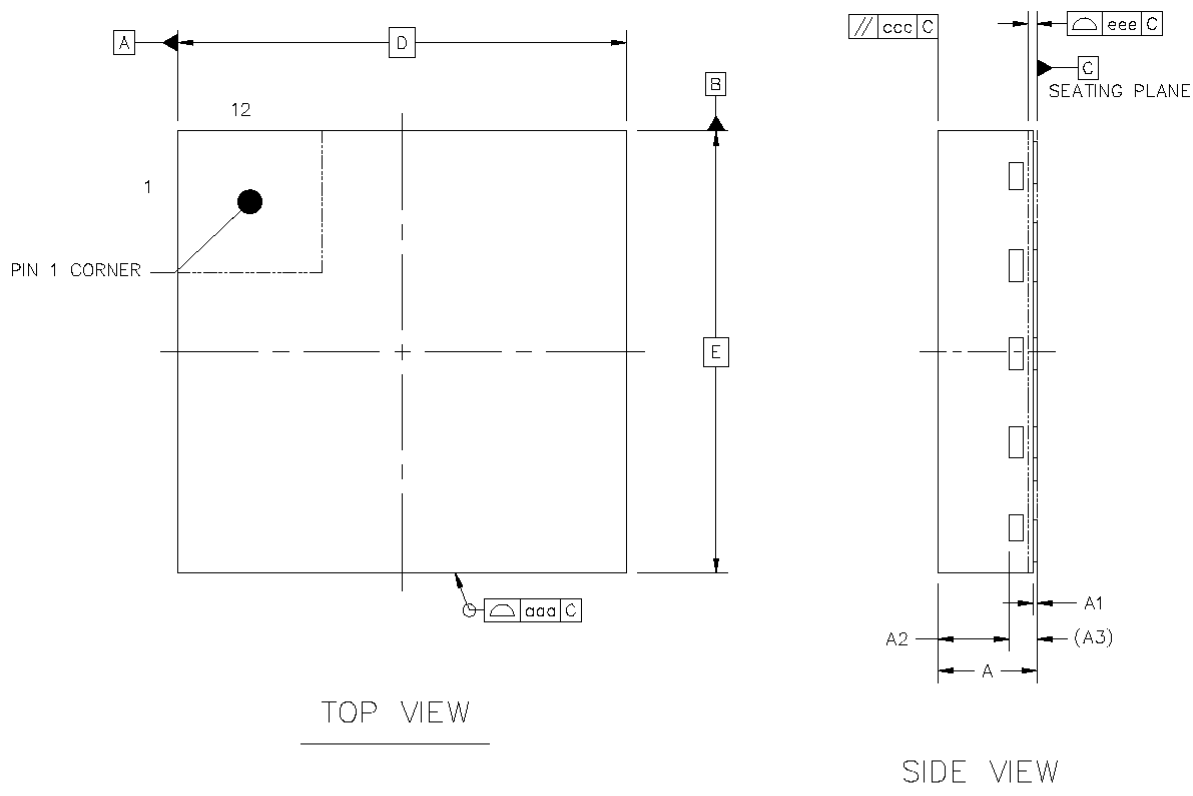

Figure 3 Serial Audio Port Timing

## DC Characteristics

PARAMETER	MIN	TYP	MAX	UNIT
<b>Normal Operation Mode</b>				
VDD Current VDD=3.3V		15		mA
<b>Power Down Mode</b>				
VDD Current VDD=3.3V		5		mA
<b>Digital Voltage Level</b>				
Input High-level Voltage	2.0			V
Input Low-level Voltage			0.8	V
Output High-level Voltage		VDD		V
Output Low-level Voltage		0		V

5. PACKAGE INFORMATION



		SYMBOL	MIN	NOM	MAX
TOTAL THICKNESS		A	0.5	0.55	0.6
STAND OFF		A1	0	0.02	0.05
MOLD THICKNESS		A2	---	0.4	---
L/F THICKNESS		A3	0.152 REF		
LEAD WIDTH		b	0.18	0.23	0.28
BODY SIZE	X	D	2.5 BSC		
	Y	E	2.5 BSC		
LEAD PITCH		e	0.5 BSC		
EP SIZE	X	D2	1.36	1.46	1.56
	Y	E2	1.36	1.46	1.56
LEAD LENGTH		L	0.1425	0.1925	0.2425
LEAD TIP TO EXPOSED PAD EDGE		K	0.265 REF		
PACKAGE EDGE TOLERANCE		aaa	0.1		
MOLD FLATNESS		ccc	0.1		
COPLANARITY		eee	0.05		
LEAD OFFSET		bbb	0.1		
EXPOSED PAD OFFSET		fff	0.1		



**6. Contact Information:**

Everest Semiconductor Co., Ltd.

苏州工业园区金鸡湖大道 1355 号国际科技园, 邮编 215021

Email: [info@everest-semi.com](mailto:info@everest-semi.com)

