



ES8218E

Low Power Audio ADC

FEATURES

System

- High performance and low power multi-bit delta-sigma audio ADC
- I²S/PCM master or slave serial data port
- Two pairs of analog input with differential input option
- 256/384Fs and USB 12/24 MHz system clocks
- Fast power up time
- I²C interface

ADC

- 24-bit, 8 to 96 kHz sampling frequency
- 96 dB signal to noise ratio, -85 dB THD+N
- Low noise pre-amplifier
- Auto level control (ALC) and noise gate
- High PSRR
- Shelving filter to compensate mic frequency response
- Support digital mic

Low Power

- 1.8V to 3.3V operation
- 9 mW record
- Low standby current

APPLICATIONS

- Wireless remote
- Portable audio

ORDERING INFORMATION

ES8218E -40°C ~ +85°C
QFN-20

1. BLOCK DIAGRAM

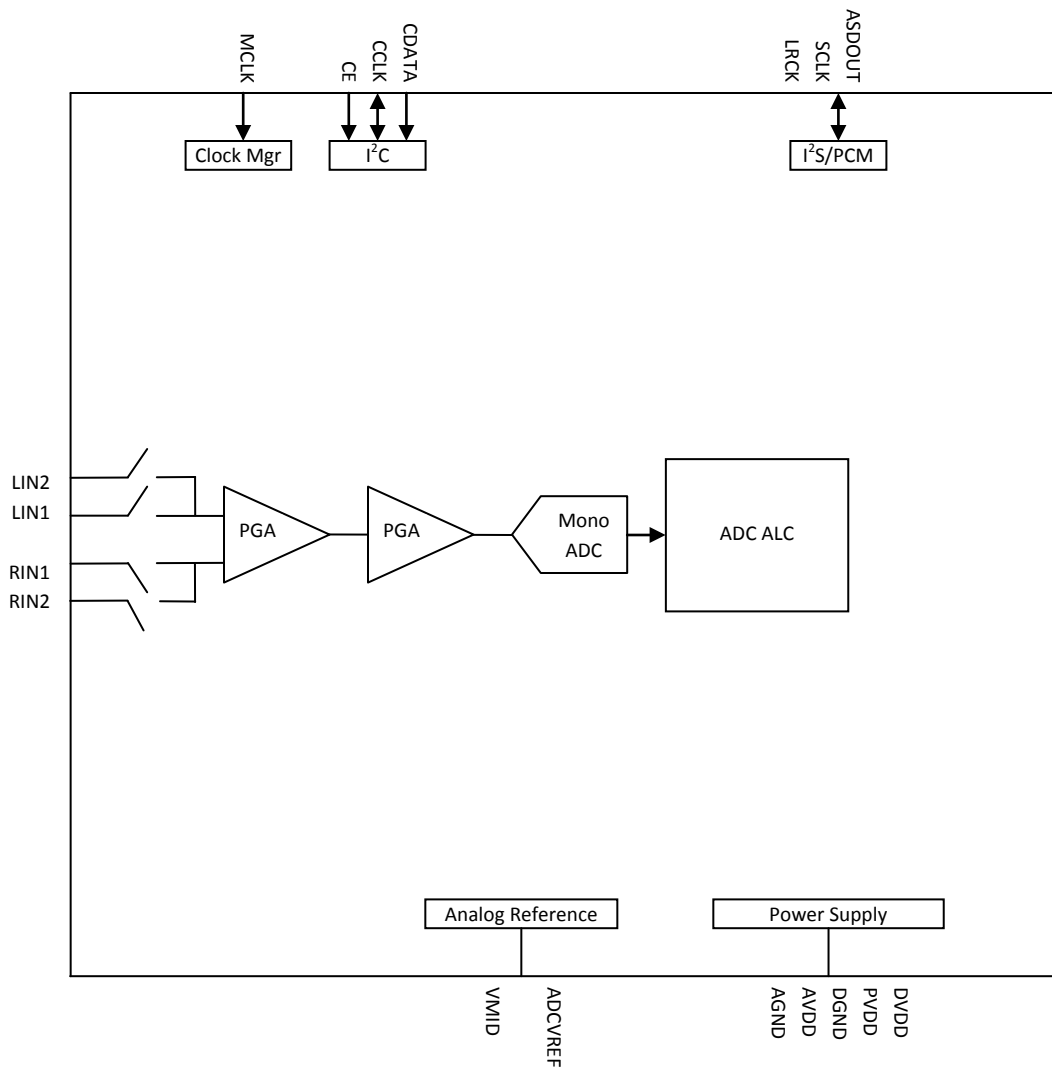

2. PIN OUT AND DESCRIPTION

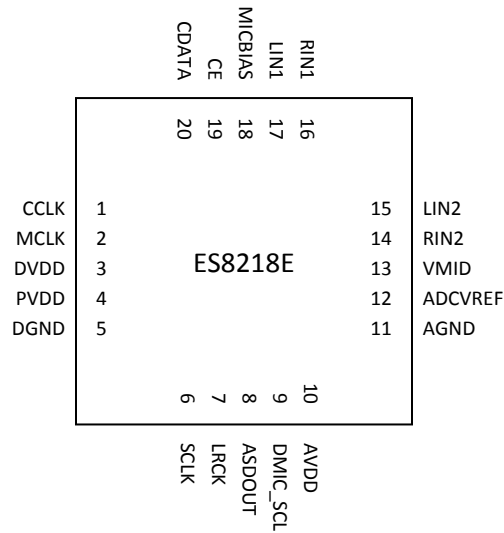

PIN	NAME	I/O	DESCRIPTION
1	CCLK	I	I ² C clock input
2	MCLK	I	Master clock
3	DVDD	Supply	Digital core supply
4	PVDD	Supply	Digital IO supply
5	DGND	Supply	Digital ground
6	SCLK	I/O	Audio data bit clock
7	LRCK	I/O	Audio data left and right clock
8	ASDOUT	O	ADC audio data
9	DMIC_SCL		Digital mic clock
10	AVDD	Supply	Analog supply
11	AGND	Supply	Analog ground
12	ADCVREF	O	Decoupling capacitor
13	VMID	O	Decoupling capacitor
14	RIN2	I	Right analog input
15	LIN2	I	Left analog input
16	RIN1	I	Right analog input
17	LIN1	I	Left analog input
18	MICBIAS		Mic bias
19	CE	I	I ² C device address selection
20	CDATA	I/O	I ² C data input or output

3. TYPICAL APPLICATION CIRCUIT

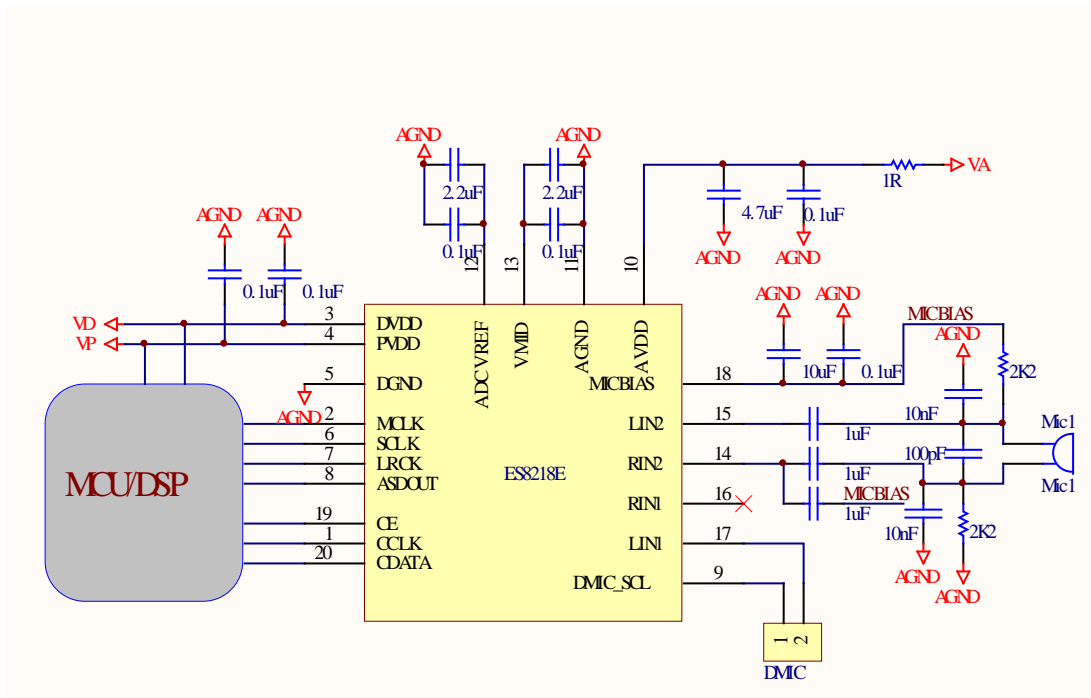

4. CLOCK MODES AND SAMPLING FREQUENCIES

The device supports two types of clocking: standard audio clocks (256Fs, 384Fs, 512Fs, etc), and USB clocks (12/24 MHz).

According to the serial audio data sampling frequency (F_s), the device can work in two speed modes: single speed mode or double speed mode. In single speed mode, F_s normally ranges from 8 kHz to 48 kHz, and in double speed mode, F_s normally range from 64 kHz to 96 kHz.

The device can work either in master clock mode or slave clock mode. In slave mode, LRCK and SCLK are supplied externally, and LRCK and SCLK must be synchronously derived from the system clock with specific rates. In master mode, LRCK and SCLK are derived internally from device master clock.

5. MICRO-CONTROLLER CONFIGURATION INTERFACE

The device supports standard I²C micro-controller configuration interface. External micro-controller can completely configure the device through writing to internal configuration registers.

I²C interface is a bi-directional serial bus that uses a serial data line (SDA) and a serial clock line (SCL) for data transfer. The timing diagram for data transfer of this interface is given in Figure 1. Data are transmitted synchronously to SCL clock on the SDA line on a byte-by-byte basis. Each bit in a byte is sampled during SCL high with MSB bit being transmitted firstly. Each transferred byte is followed by an acknowledge bit from receiver to pull the SDA low. The transfer rate of this interface can be up to 100 kbps.

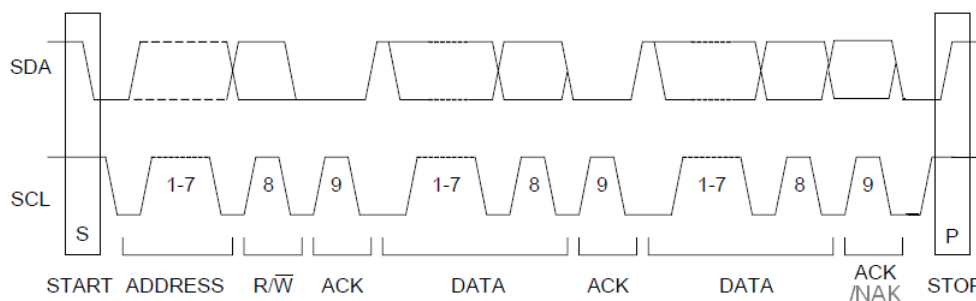

Figure 1 Data Transfer for I²C Interface

A master controller initiates the transmission by sending a “start” signal, which is defined as a high-to-low transition at SDA while SCL is high. The first byte transferred is the slave address. It is a seven-bit chip address followed by a RW bit. The chip address must be 001000x, where x equals ADO. The RW bit indicates the slave data transfer direction. Once an acknowledge bit is received, the data transfer starts to proceed on a byte-by-byte basis in the direction specified by the RW bit. The master can terminate the communication by generating a “stop” signal, which is defined as a low-to-high transition at SDA while SCL is high.

In I²C interface mode, the registers can be written and read. The formats of “write” and “read” instructions are shown in Table 1 and Table 2. Please note that, to read data from a register, you must set R/W bit to 0 to access the register address and then set R/W to 1 to read data from the register.

Table 1 Write Data to Register in I²C Interface Mode

Chip Address		R/W		Register Address		Data to be written
001000	AD0	0	ACK	RAM	ACK	DATA

Table 2 Read Data from Register in I²C Interface Mode

Chip Address		R/W		Register Address
001000	AD0	0	ACK	RAM
Chip Address		R/W		Data to be read
001000	AD0	1	ACK	Data

6. DIGITAL AUDIO INTERFACE

The device provides many formats of serial audio data interface to the output from the ADC through LRCK, BCLK (SCLK) and ADCDAT pins. These formats are I²S, left justified and DSP/PCM mode. ADC data is out at ADCDAT on the falling edge of SCLK. The relationships of SDATA (ADCDAT), SCLK and LRCK with these formats are shown through Figure 2 to Figure 6.

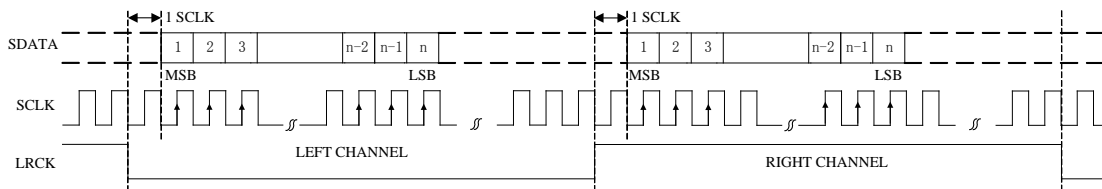

Figure 2 I²S Serial Audio Data Format Up To 24-bit

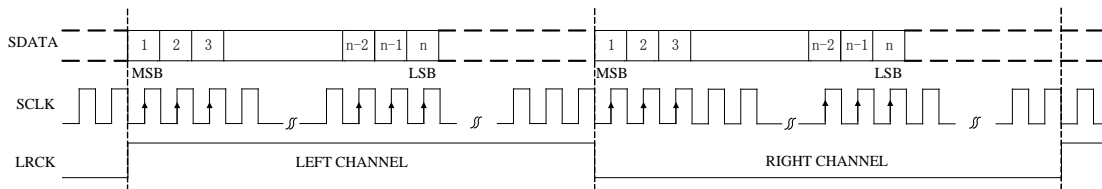

Figure 3 Left Justified Serial Audio Data Format Up To 24-bit

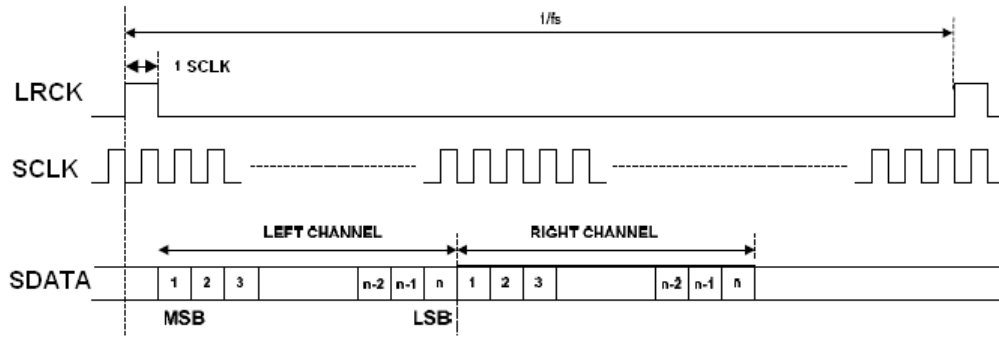

Figure 5 DSP/PCM Mode A

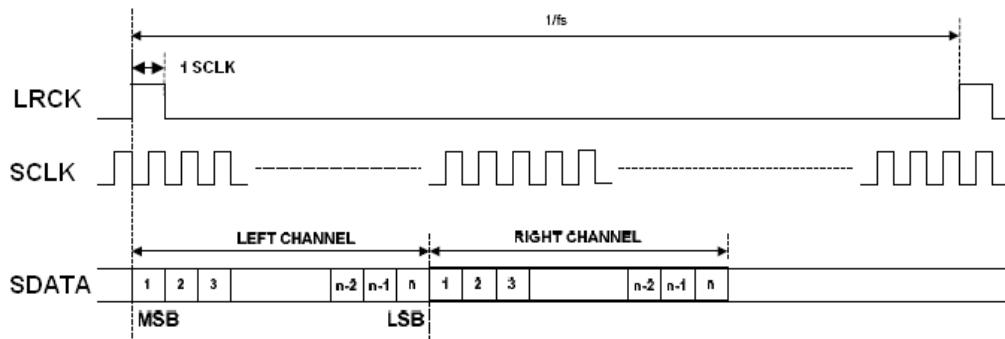

Figure 6 DSP/PCM Mode B

7. ELECTRICAL CHARACTERISTICS

ABSOLUTE MAXIMUM RATINGS

Continuous operation at or beyond these conditions may permanently damage the device.

PARAMETER	MIN	MAX
Analog Supply Voltage Level	-0.3V	+5.0V
Digital Supply Voltage Level	-0.3V	+5.0V
Input Voltage Range	DGND-0.3V	DVDD+0.3V
Operating Temperature Range	-40°C	+85°C
Storage Temperature	-65°C	+150°C

RECOMMENDED OPERATING CONDITIONS

PARAMETER	MIN	TYP	MAX	UNIT
Analog Supply Voltage Level	1.6	3.3	3.6	V
Digital Supply Voltage Level	1.6	1.8	3.6	V

ADC ANALOG AND FILTER CHARACTERISTICS AND SPECIFICATIONS

Test conditions are as the following unless otherwise specify: AVDD=3.3V, DCVDD=1.8V, AGND=0V, DGND=0V, Ambient temperature=25°C, Fs=48 KHz, 96 KHz or 192 KHz, MCLK/LRCK=256.

PARAMETER	MIN	TYP	MAX	UNIT
ADC Performance				
Signal to Noise ratio (A-weight)	90	96	98	dB
THD+N	-88	-85	-75	dB
Gain Error			±5	%
Filter Frequency Response – Single Speed				
Passband	0		0.4535	Fs
Stopband	0.5465			Fs
Passband Ripple			±0.05	dB
Stopband Attenuation	50			dB
Filter Frequency Response – Double Speed				
Passband	0		0.4167	Fs
Stopband	0.5833			Fs
Passband Ripple			±0.005	dB
Stopband Attenuation	50			dB
Analog Input				
Full Scale Input Level		AVDD/3.3		Vrms
Input Impedance		20		KΩ

POWER CONSUMPTION CHARACTERISTICS

PARAMETER	MIN	TYP	MAX	UNIT
Normal Operation Mode				
DVDD=1.8V, PVDD=1.8V, AVDD=1.8V:		9		mW
DVDD=3.3V, PVDD=3.3V, AVDD=3.3V:		28		
Power Down Mode				
DVDD=1.8V, PVDD=1.8V, AVDD=1.8V		0.1		uA
DVDD=3.3V, PVDD=3.3V, AVDD=3.3V		0.1		uA

SERIAL AUDIO PORT SWITCHING SPECIFICATIONS

PARAMETER	Symbol	MIN	MAX	UNIT
MCLK frequency			51.2	MHz
MCLK duty cycle		40	60	%
LRCK frequency			200	KHz
LRCK duty cycle		40	60	%
SCLK frequency			26	MHz
SCLK pulse width low	TSCLKL	15		ns
SCLK Pulse width high	TSCLKH	15		ns
SCLK falling to LRCK edge	TSLR	-10	10	ns
SCLK falling to SDOUT valid	TSDO	0		ns
SDIN valid to SCLK rising setup time	TSDIS	10		ns
SCLK rising to SDIN hold time	TSDIH	10		ns

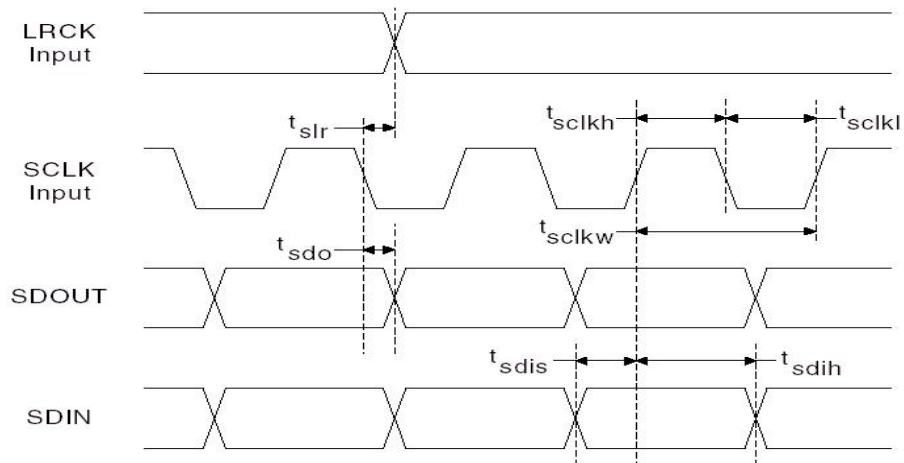

Figure 8 Serial Audio Port Timing

I²C SWITCHING SPECIFICATIONS

PARAMETER	Symbol	MIN	MAX	UNIT
SCL Clock Frequency	FSCL		400	KHz
Bus Free Time Between Transmissions	TTWID	1.3		us
Start Condition Hold Time	TTWSTH	0.6		us
Clock Low time	TTWCL	1.3		us
Clock High Time	TTWCH	0.4		us
Setup Time for Repeated Start Condition	TTWSTS	0.6		us
SDA Hold Time from SCL Falling	TTWDH		900	ns
SDA Setup time to SCL Rising	TTWDS	100		ns
Rise Time of SCL	TTWR		300	ns
Fall Time SCL	TTWF		300	ns

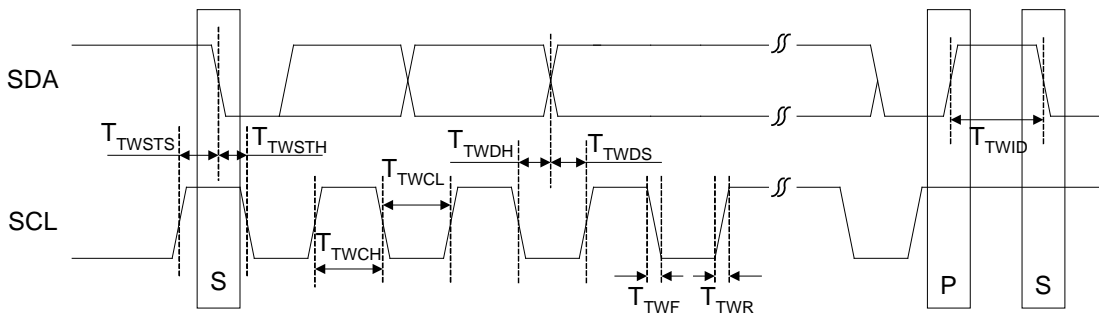
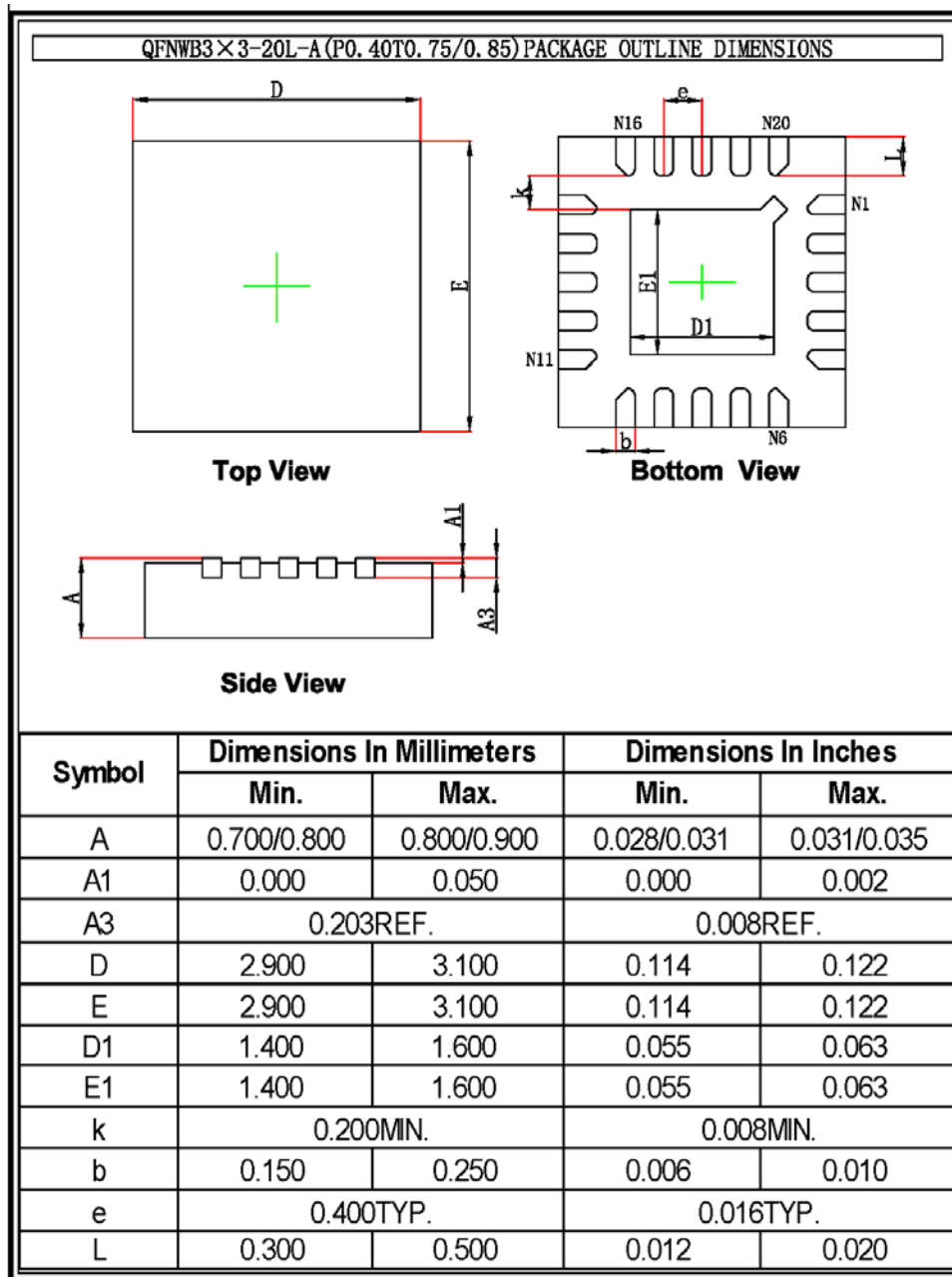

Figure 10 I²C Timing

8. PACKAGE



9. CORPORATE INFORMATION

Everest Semiconductor Co., Ltd.

No. 1355 Jinjihu Drive, Suzhou Industrial Park, Jiangsu, P.R. China, Zip Code 215021

苏州工业园区金鸡湖大道 1355 号国际科技园, 邮编 215021

Email: info@everest-semi.com

