

## Compact Push-Type Power Switches

Malaysia

Series: **R1**  
 Type: **ESB92S**

Highly-reliable type, applicable to wide range of purposes

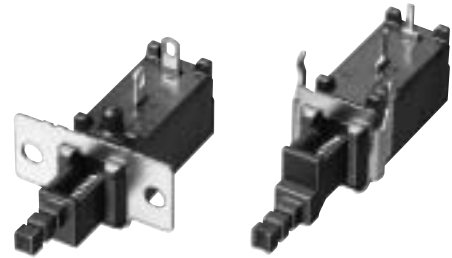

### ■ Features

- Power switches exclusively for SPST use
- Withstands inrush current up to 128 A
- Special heat resistant structure
- Meets the world's major safety standards
- Rapid switching structure, applicable to IEC60065 6th edition (Refer to the notes.)
- Cadmium-free contact

### ■ Recommended Applications

- AV Equipment: TVs and Audio Systems
- OA Equipment: Personal Computers, Display Monitors, Printers, etc.

### ■ Explanation of Part Numbers

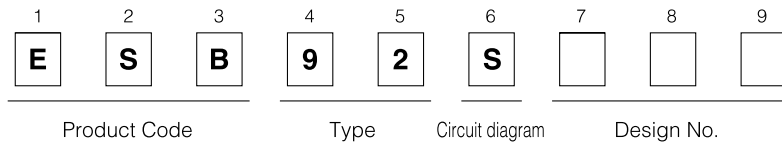

### ■ Major Specifications

Rating	TV-5, 5 A 250 Vac (UL, CSA) 4 A/128 A 250 Vac (European standards)		
Safety Standards	UL, CSA, VDE, BEAB, SEMKO, FIMKO, SEV, DEMKO, NEMKO		
Circuit Diagram	SPST		
Operating Force	Circuit	Lock Travel	
		1.5 mm	2.5 mm
	SPST	6.0 N±2.0 N	6.0 N±2.0 N
Travel	Lock Travel: 2.5 mm, Full Travel: 3.5 mm		
	Lock Travel: 1.5 mm, Full Travel: 2.5 mm		
Minimum Quantity/Packing Unit	50 pcs. (Vinyl Bag)		
Quantity/Carton	600 pcs.		

\* OA equipment: Personal computers, display monitors, printers etc.

Design and specifications are each subject to change without notice. Ask factory for the current technical specifications before purchase and/or use. Should a safety concern arise regarding this product, please be sure to contact us immediately.

■ Dimensions in mm (not to scale)

### No. 1

Solder lug type

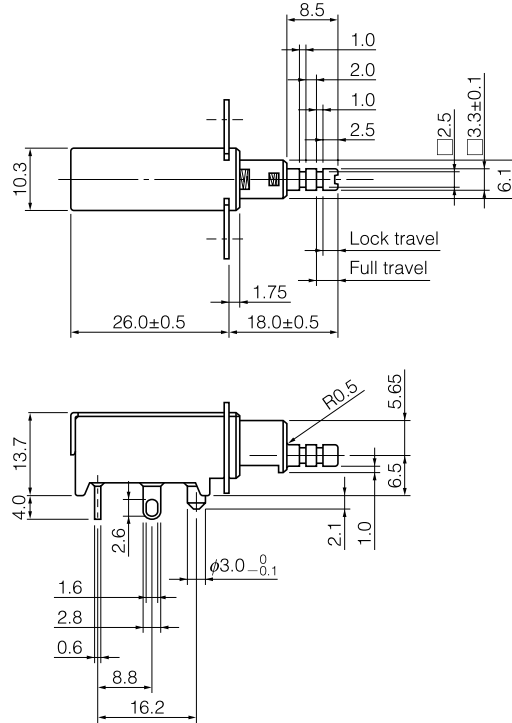

Part No.	Travel		Circuit Diagram
	Lock	Full	
ESB92S27B	2.5 mm	3.5 mm	SPST
ESB92S17B	1.5 mm	2.5 mm	

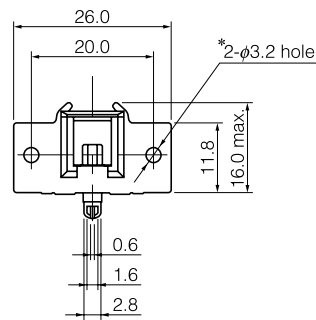

\*Mounting Spec with M3 Top

### No. 2

PWB mount type

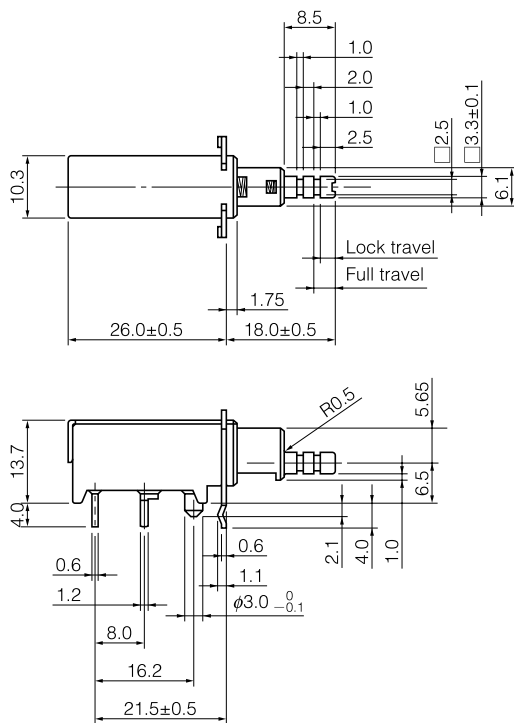

Part No.	Travel		Circuit Diagram
	Lock	Full	
ESB92S21B	2.5 mm	3.5 mm	SPST
ESB92S11B	1.5 mm	2.5 mm	

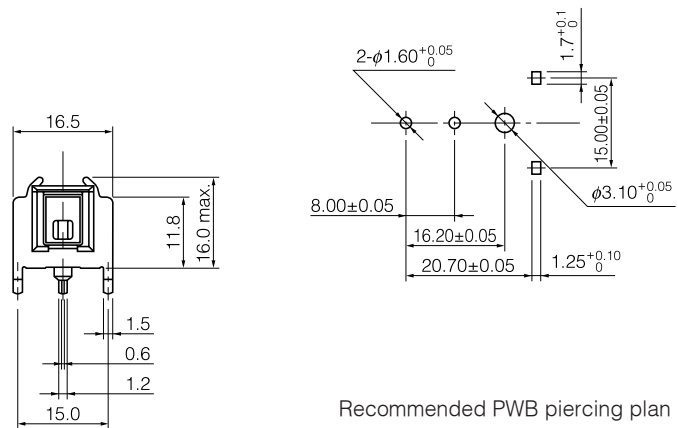

Recommended PWB piercing plan  
View from terminal side

■ Dimensions in mm (not to scale)

