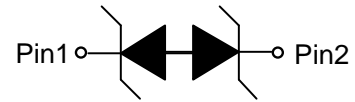

ESD56131W
1-Line, Bi-directional, Transient Voltage Suppressor
<http://www.sh-willsemi.com>
Descriptions

The ESD56131W is a Bi-directional TVS (Transient Voltage Suppressor). It is specifically designed to protect sensitive electronic components which are connected to power lines from over-stress caused by ESD (Electrostatic Discharge), EFT (Electrical Fast Transients) and Lightning.

The ESD56131W may be used to provide ESD protection up to $\pm 30\text{kV}$ (contact and air discharge) according to IEC61000-4-2, and with high surge capability used to protect USB voltage bus pin according to IEC61000-4-5.

The ESD56131W is available in SOD-323F package. Standard products are Pb-free and Halogen-free.

SOD-323F (Bottom View)

Circuit diagram
Features

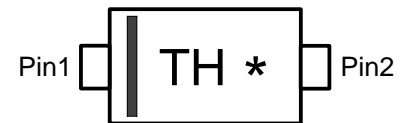
- Reverse stand-off voltage: $\pm 4.6\text{V}$
- Transient protection according to IEC61000-4-2 (ESD): $\pm 30\text{kV}$ (contact and air discharge)
IEC61000-4-4 (EFT): 80A (5/50ns)
IEC61000-4-5 (surge): 100A (8/20 μs)
- Capacitance: $C_J = 250\text{pF}$ typ.
- Low clamping voltage
- Solid-state silicon technology



TH = Device code

* = Month code

Marking (Top View)
Applications

- Power supply protection
- Power management

Order information

Device	Package	Shipping
ESD56131W-2/TR	SOD-323F	3000/Tape&Reel

Absolute maximum ratings

Parameter	Symbol	Rating	Unit
Peak pulse power ($t_p=8/20\mu s$)	P_{pk}	1400	W
Peak pulse current ($t_p = 8/20\mu s$)	I_{PP}	100	A
ESD according to IEC61000-4-2 air discharge	V_{ESD}	± 30	kV
ESD according to IEC61000-4-2 contact discharge		± 30	
Junction temperature	T_J	125	$^{\circ}C$
Operating temperature	T_{OP}	-40~85	$^{\circ}C$
Lead temperature	T_L	260	$^{\circ}C$
Storage temperature	T_{STG}	-55~150	$^{\circ}C$

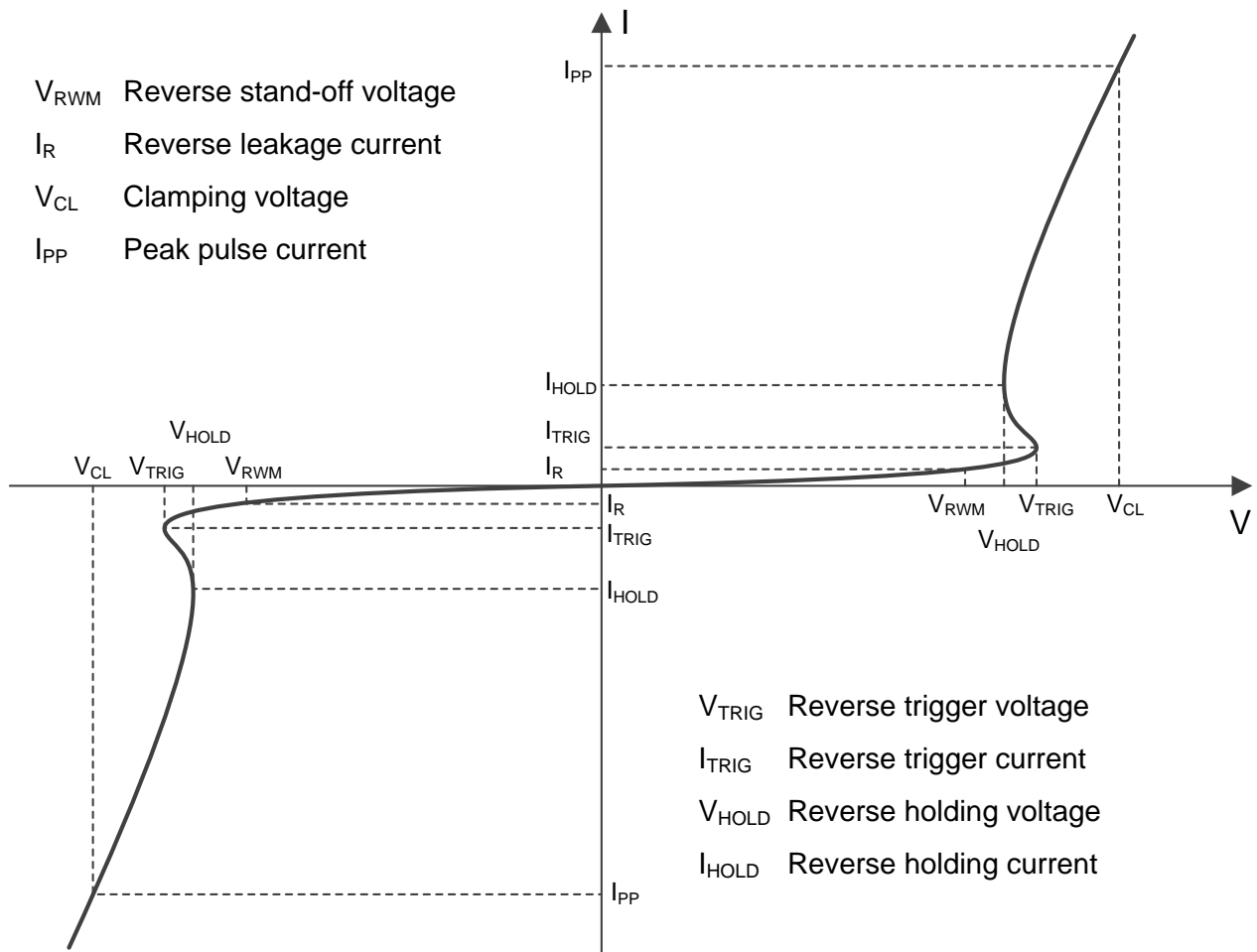
Electrical characteristics ($T_A = 25^{\circ}C$, unless otherwise noted)

Definitions of electrical characteristics

Electrical characteristics ($T_A = 25^\circ\text{C}$, unless otherwise noted)

Parameter	Symbol	Condition	Min.	Typ.	Max.	Unit
Reverse maximum working voltage	V_{RWM}				± 4.6	V
Reverse leakage current	I_R	$V_{RWM} = 4.6\text{V}$			1	μA
Reverse breakdown voltage	V_{BR}	$I_{BR} = 1\text{mA}$	4.8			V
Reverse holding voltage	V_{HOLD}	$I_{HOLD} = 50\text{mA}$	4.8			V
Clamping voltage ¹⁾	V_{CL}	$V_{ESD} = 8\text{kV}$		8.0		V
Clamping voltage ²⁾	V_{CL}	$I_{PP} = 1\text{A}, t_p = 8/20\mu\text{s}$			6	V
		$I_{PP} = 50\text{A}, t_p = 8/20\mu\text{s}$			10	V
		$I_{PP} = 100\text{A}, t_p = 8/20\mu\text{s}$			14	V
Junction capacitance	C_J	$V_R = 0\text{V}, f = 1\text{MHz}$		250	300	pF

Notes:

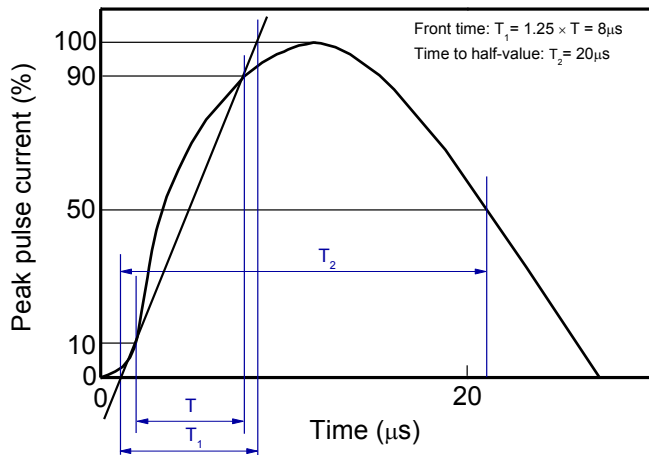
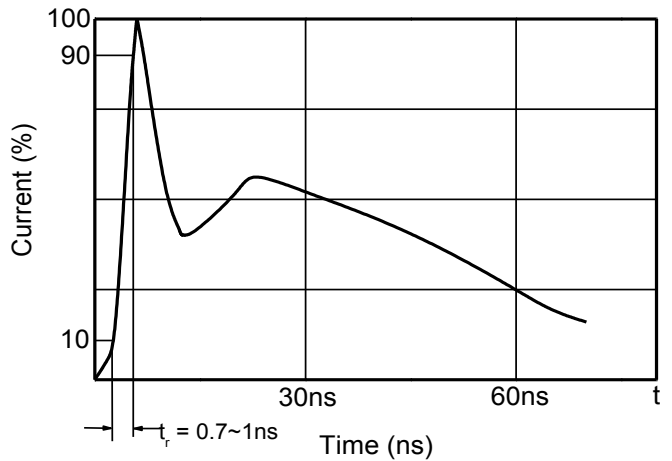
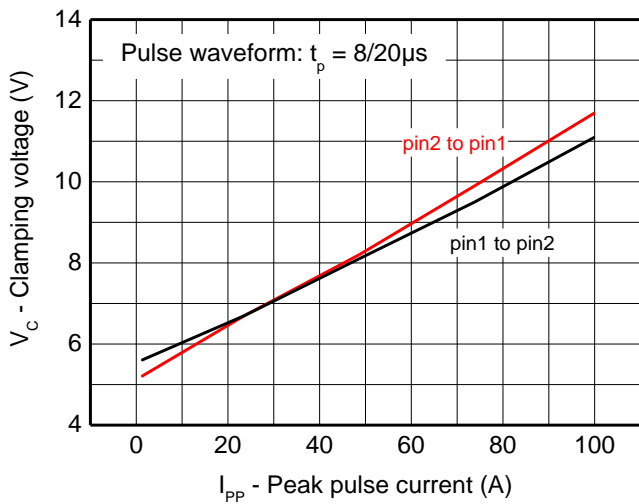
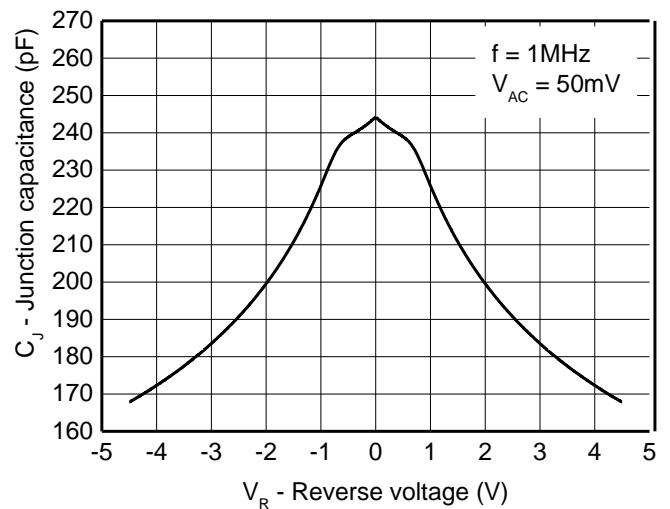
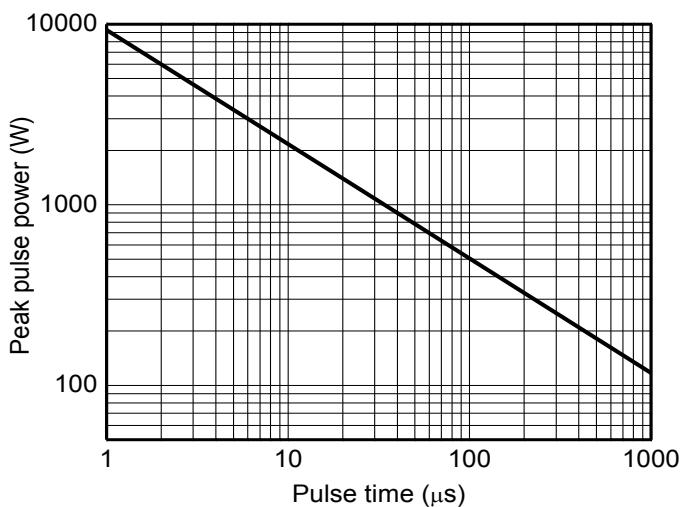
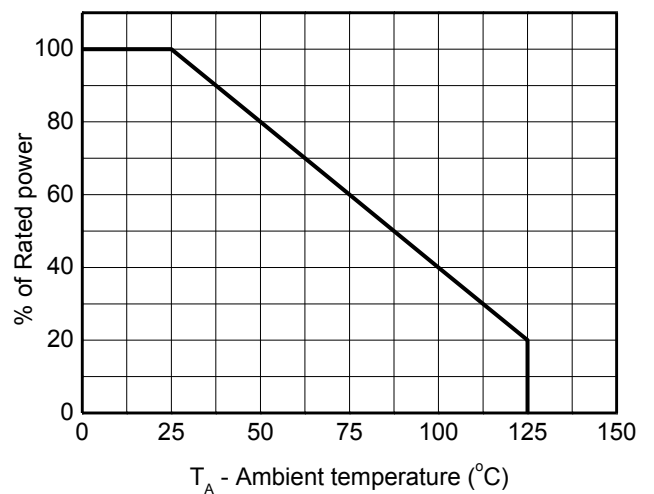
- 1) Contact discharge mode, according to IEC61000-4-2.
- 2) Non-repetitive current pulse, according to IEC61000-4-5.

Typical characteristics ($T_A = 25^\circ\text{C}$, unless otherwise noted)

8/20 μs waveform per IEC61000-4-5

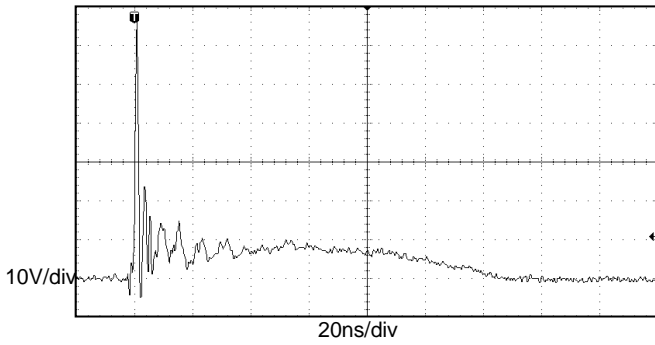
Contact discharge current waveform per IEC61000-4-2

Clamping voltage vs. Peak pulse current

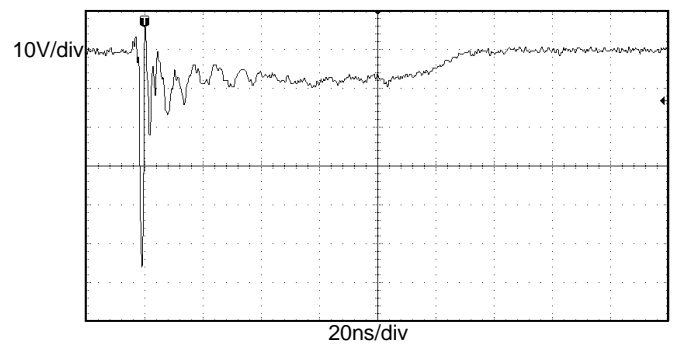
Capacitance vs. Reverse voltage

Non-repetitive peak pulse power vs. Pulse time

Power derating vs. Ambient temperature

Typical characteristics ($T_A=25^\circ\text{C}$, unless otherwise noted)



ESD clamping
(+8kV contact discharge per IEC61000-4-2)

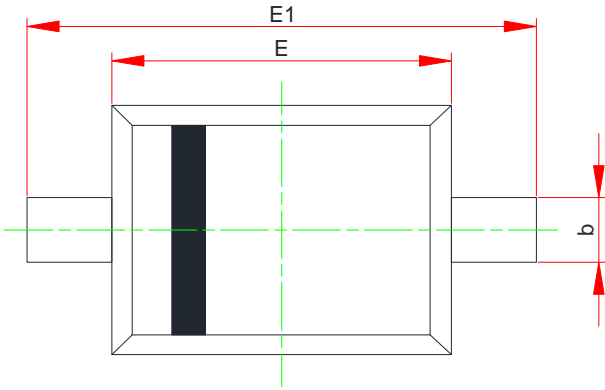
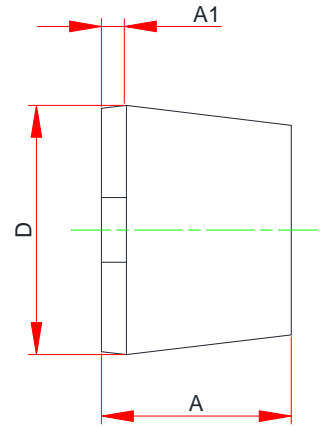
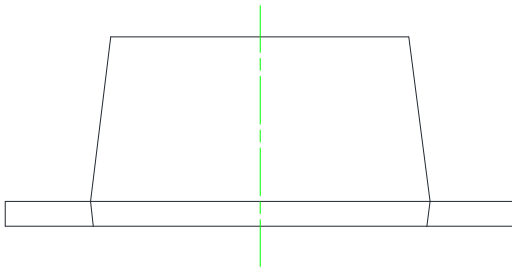

ESD clamping
(-8kV contact discharge per IEC61000-4-2)

Package outline dimensions
SOD-323F

Top View

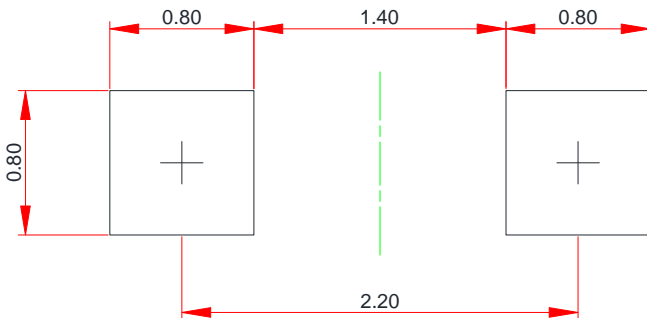
Side View

Side View

Symbol	Dimensions in Millimeters		
	Min.	Typ.	Max.
A	0.80	-	1.10
A1	0.10	-	0.15
D	1.15	-	1.35
E	1.60	-	1.80
E1	2.30	-	2.80
b	0.25	-	0.40

Recommend land pattern (Unit: mm)

Notes:

This recommended land pattern is for reference purposes only. Please consult your manufacturing group to ensure your PCB design guidelines are met.