

Features

- Ultra small package: 1.0x0.6x0.5mm
- Ultra low capacitance: 0.3pF typical (I/O-I/O)
- Ultra low leakage: nA level
- Low operating voltage: 5V
- Low clamping voltage
- 3-pin leadless package
- Up to 2-line protects
- Complies with following standards:
 - IEC 61000-4-2 (ESD) immunity test
Air discharge: $\pm 30\text{kV}$
Contact discharge: $\pm 25\text{kV}$
 - IEC61000-4-4 (EFT) 40A (5/50ns)
 - IEC61000-4-5 (Lightning) 5A (8/20 μs)
- RoHS Compliant

Mechanical Characteristics

- Package: DFN1006-3 (1.0x0.6x0.5mm)
- Lead Finish: NiPdAu
- Case Material: "Green" Molding Compound.
- UL Flammability Classification Rating 94V-0
- Moisture Sensitivity: Level 3 per J-STD-020
- Terminal Connections: See Diagram Below

Applications

- Cellular Handsets & Accessories
- Digital Visual Interface (DVI)
- Display Port
- MDDI Ports
- USB Ports
- PCI Express
- Serial ATA

Ordering Information

Part Number	Qty per Reel	Reel Size
ESD5V0U03-DFN3	10000	7"

Dimensions and Pin Configuration

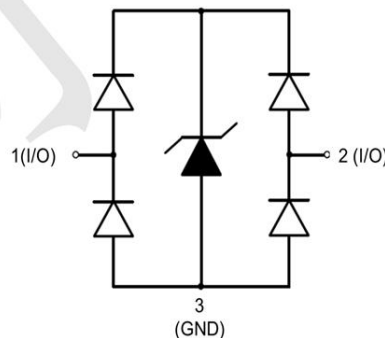
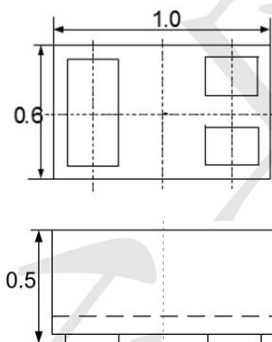

Marking:5*

*** =wafer tracking no**

Parameter	Symbol	Value	Unit
Peak Pulse Power (8/20 μ s)	Ppk	90	W
Peak Pulse Current (8/20 μ s)	I _{PP}	5	A
ESD per IEC 61000-4-2 (Air)	V _{ESD}	± 30	kV
ESD per IEC 61000-4-2 (Contact)		± 25	
Operating Temperature Range	T _J	-55 to +125	$^{\circ}$ C
Storage Temperature Range	T _{stg}	-55 to +150	$^{\circ}$ C

Parameter	Symbol	Min	Typ	Max	Unit	Test Condition
Reverse Working Voltage	V _{RWM}			5	V	Pin 1 or pin 2 to pin 3 and between pin 1 and pin 2
Breakdown Voltage	V _{BR}	6			V	I _T = 1mA, pin 1 or pin 2 to pin 3 and between pin 1 and pin 2
Reverse Leakage Current	I _R			0.5	μ A	V _{RWM} = 5V, Pin 1 or pin 2 to pin 3 and between pin 1 and pin 2
Clamping Voltage	V _c		10	12	V	I _{PP} = 1A (8 x 20 μ s pulse), pin 1 or pin 2 to pin 3
Clamping Voltage	V _c		13	15	V	I _{PP} = 5A (8 x 20 μ s pulse), pin 1 or pin 2 to pin 3
Junction Capacitance	C _J		0.3		pF	V _R = 0V, f = 1MHz, between pin 1 and pin 2
Junction Capacitance	C _J		0.6		pF	V _R = 0V, f = 1MHz, pin 1 or pin 2 to pin 3

Typical Performance Characteristics ($T_A=25^\circ\text{C}$ unless otherwise Specified)

Fig1. 8/20 μs Pulse Waveform

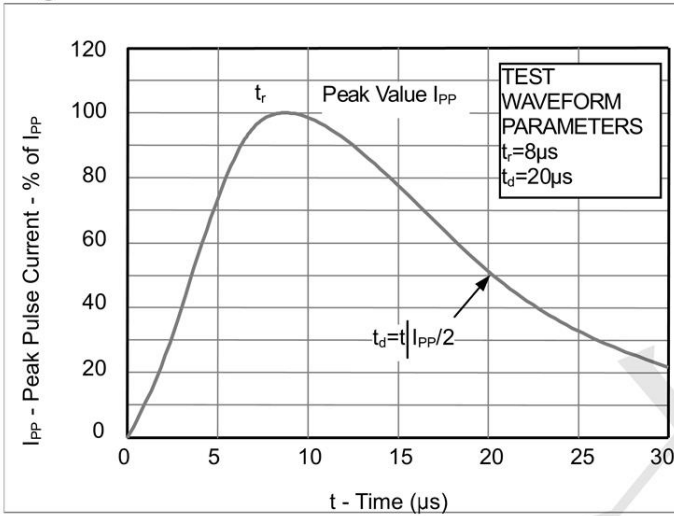

Fig2. ESD Pulse Waveform (according to IEC 61000-4-2)

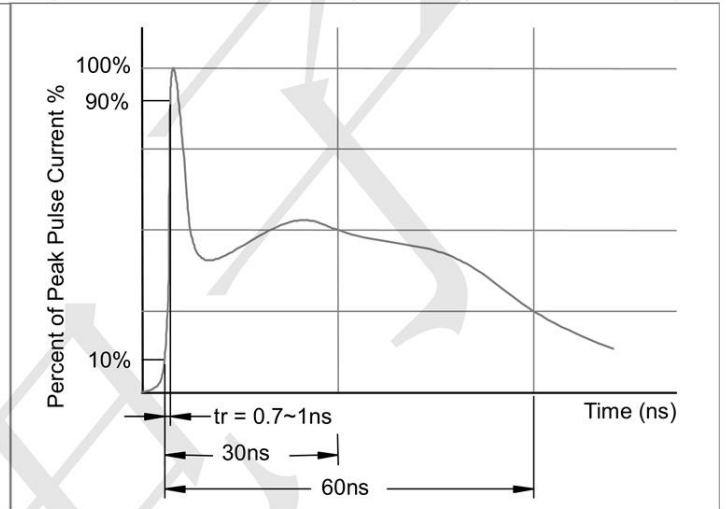
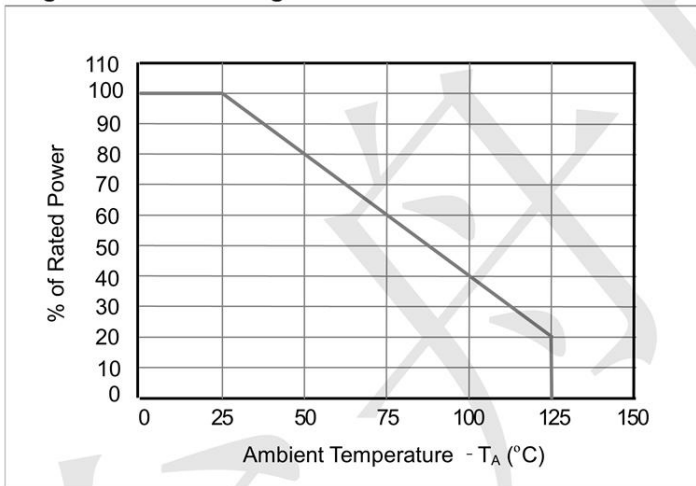
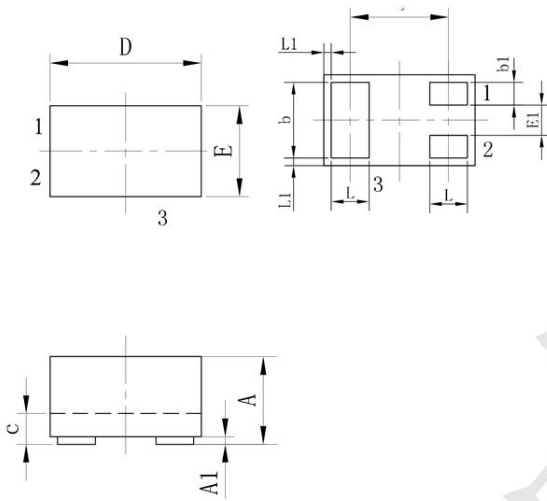

Fig3. Power Derating Curve



Outline Drawing - DFN1006-3



SYM	DIMENSIONS					
	MILLIMETERS			INCHES		
	MIN	NOM	MAX	MIN	NOM	MAX
A	0.45	0.50	0.55	0.018	0.020	0.022
A1	0.00	0.02	0.05	0.000	0.001	0.002
b	0.45	0.50	0.55	0.018	0.020	0.022
b1	0.10	0.15	0.20	0.004	0.006	0.008
c	0.12	0.15	0.18	0.005	0.006	0.007
D	0.95	1.00	1.05	0.037	0.039	0.041
e	0.65 BSC			0.026 BSC		
E	0.55	0.60	0.65	0.022	0.024	0.026
E1	0.15	0.20	0.25	0.006	0.008	0.010
L	0.20	0.25	0.30	0.008	0.010	0.012
L1	0.05 REF			0.0002 REF		

Land Pattern -DFN1006-3

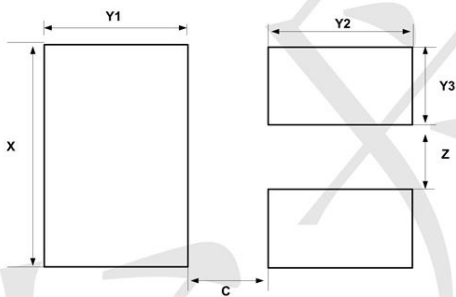

SYM	DIMENSIONS	
	MILLIMETERS	INCHES
C	0.25	0.010
X	0.65	0.024
Y1	0.50	0.020
Y2	0.50	0.020
Y3	0.25	0.010
Z	0.20	0.008