

Preliminary

ES/FMM5804YD

K,Ka-Band Power Amplifier MMIC

FEATURES

- High Output Power; P_{1dB} = 24.5 dBm (Typ.)
- High Linear Gain; G_L = 17 dB(Typ.)
- Frequency Band ; 17.5 - 30.0 GHz
- SMT Laminate Package (YD Package)
- Impedance Matched Z_{in}/Z_{out} = 50Ω

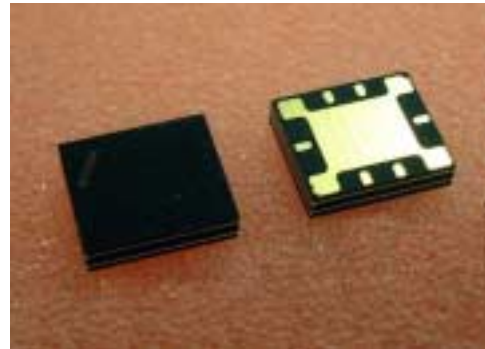

DESCRIPTION

The FMM5804YD is a power amplifier MMIC that contains a four stage amplifier, internally matched, for standard communications band in 17.5 to 30.0GHz frequency range. This product is well suited for P-to-P, Ka-band V-SAT applications.

Eudyna's stringent Quality Assurance Program assures the highest reliability and consistent performance.

ABSOLUTE MAXIMUM RATING

Item	Symbol	Condition	Unit
Drain-Source Voltage	V _{DD}	10	V
Gate-Source Voltage	V _{GG}	-3	V
Input Power	P _{in}	16	dBm
Storage Temperature	T _{stg}	-55 to +125	°C

RECOMMENDED OPERATING CONDITIONS

Item	Symbol	Recommend	Unit
Drain-Source Voltage	V _{DD}	<= 6	V
Input Power	P _{in}	<= +13	dBm
Operating Case Temperature	T _c	-40 to +85	°C

ELECTRICAL CHARACTERISTICS (Ambient Temperature T_a=25°C)

Item	Symbol	Test Conditions	Limits			Unit
			Min.	Typ.	Max.	
Output Power at 1dB G.C.P.	P _{1dB}	V _{DD} =6V typ. I _{DD(DC)} =250mA typ. Z _S =Z _L =50ohm	22.5	24.5	-	dBm
Power Gain at 1dB G.C.P.	G _{1dB}		13	16	-	dB
Power-added Efficiency at 1dB G.C.P.	η _{add}		-	10	-	%
Drain Current at 1dB G.C.P.	I _{DDRF}		-	350	430	mA
Input Return Loss (at Pin=-20dBm)	RL _{in}		-	-15	-	dB
Output Return Loss (at Pin=-20dBm)	RL _{out}		-	-8	-	dB

G.C.P. : Gain Compression Point

ESD	Class 0	~ 199V
-----	---------	--------

Note : Based on EIAJ ED-4701 C-111A(C=100pF, R=1.5kW)

Case Style	YD
------------	----

ES/FMM5804YD

K, Ka-Band Power Amplifier MMIC

Output Power vs. Frequency
@ VDD=6V, IDD(DC)=250mA

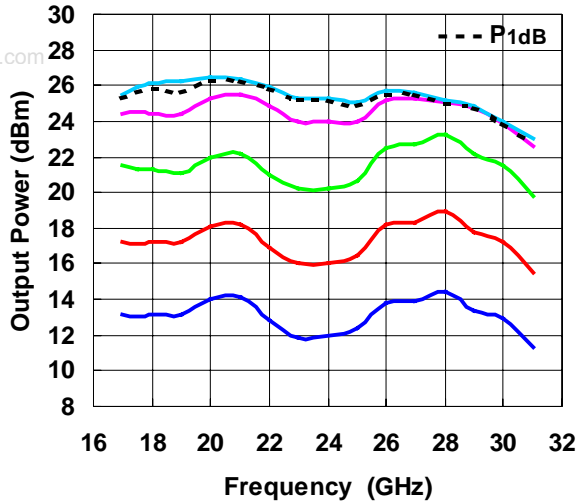

Pin=-4dBm 0dBm 4dBm
8dBm 12dBm

Power Added Efficiency vs. Frequency
@ VDD=6V, IDD(DC)=250mA

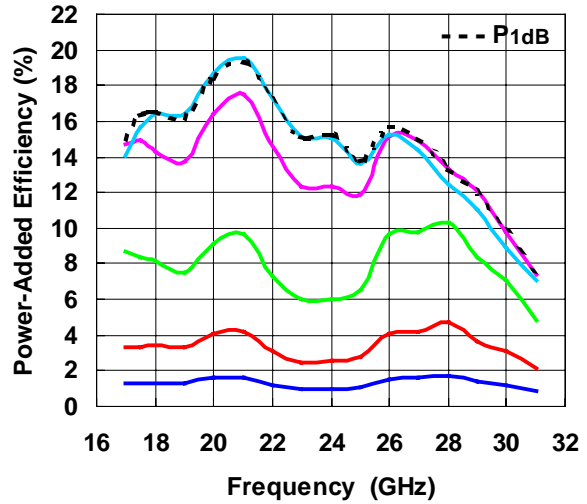

Pin=-4dBm 0dBm 4dBm
8dBm 12dBm

Output Power, Drain Current vs. Input Power
@ VDD=6V, IDD(DC)=250mA

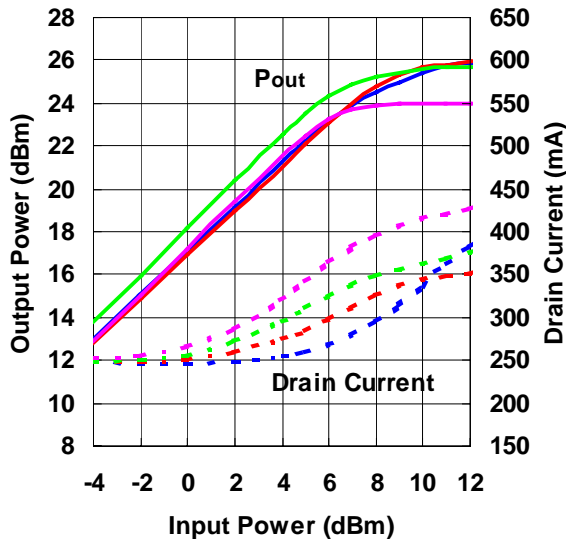

17.5GHz 22GHz 26GHz 30GHz

IMD Performance vs. Total Output Power
@ VDD=6V, IDD(DC)=250mA
 $\Delta f = +10\text{MHz}$, 2-Tone test

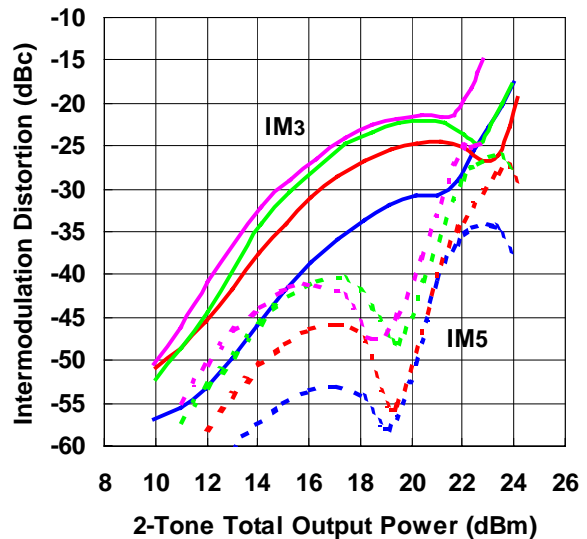

17.5GHz 22GHz 26GHz 30GHz

Eudyna

ES/FMM5804YD

K,Ka-Band Power Amplifier MMIC

Output Power, Drain Current vs. Input Power by Drain Current
@ freq.=17.5GHz, VDD=6V

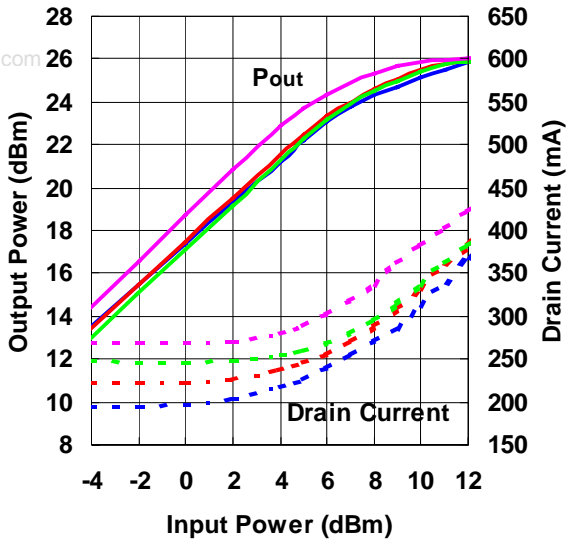

— 200mA — 225mA — 250mA — 275mA

Output Power, Drain Current vs. Input Power by Drain Current
@ freq.=22GHz, VDD=6V

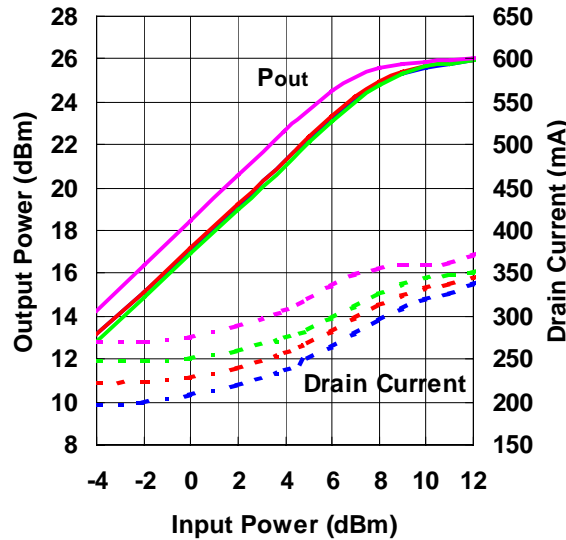

— 200mA — 225mA — 250mA — 275mA

Output Power, Drain Current vs. Input Power by Drain Current
@ freq.=26GHz, VDD=6V

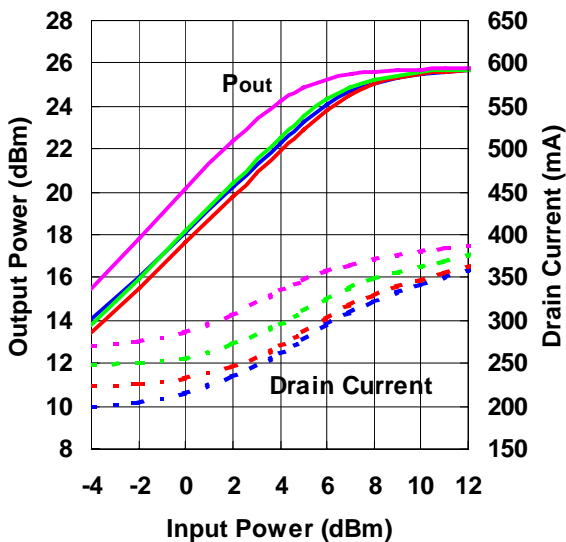

— 200mA — 225mA — 250mA — 275mA

Output Power, Drain Current vs. Input Power by Drain Current
@ freq.=30GHz, VDD=6V

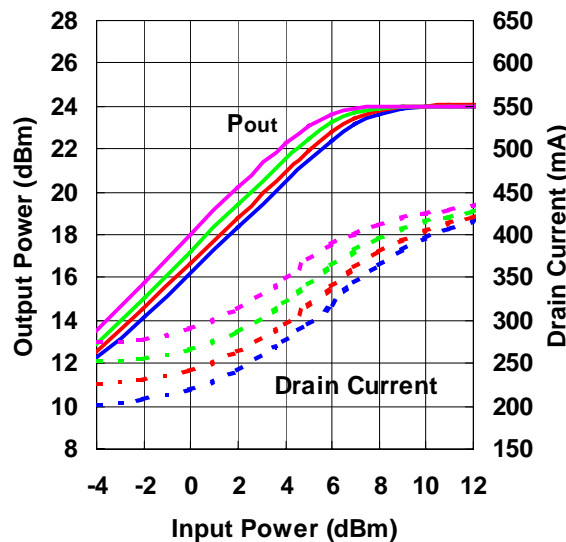

— 200mA — 225mA — 250mA — 275mA

ES/FMM5804YD

K, Ka-Band Power Amplifier MMIC

Output Power, Drain Current vs. Input Power by Drain Voltage @ freq.=17.5GHz, I_{DD}(DC)=250mA

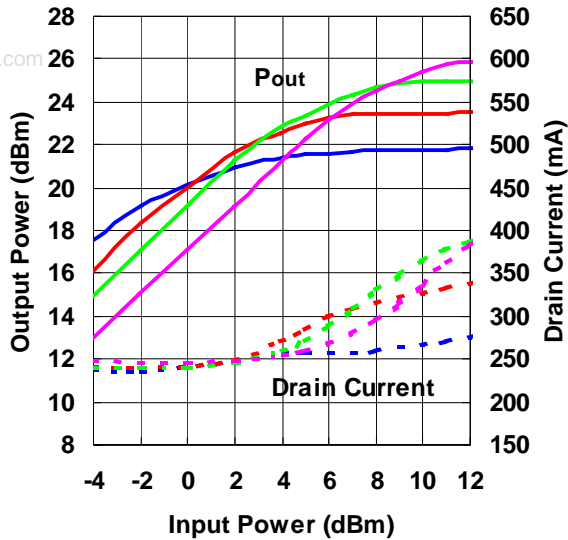

— 3V — 4V — 5V — 6V

Output Power, Drain Current vs. Input Power by Drain Voltage @ freq.=22GHz, I_{DD}(DC)=250mA

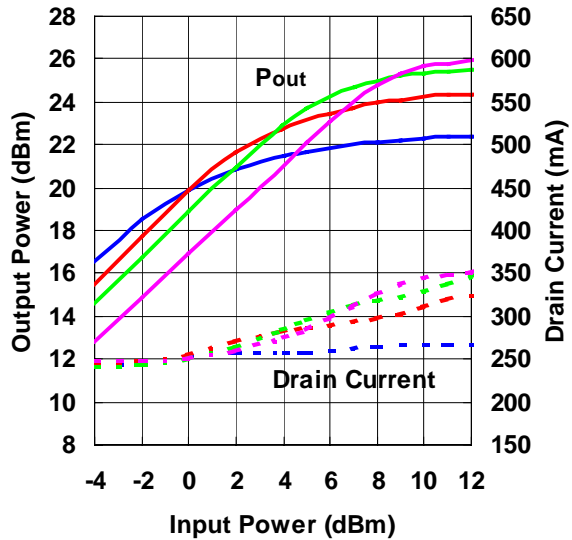

— 3V — 4V — 5V — 6V

Output Power, Drain Current vs. Input Power by Drain Voltage @ freq.=26GHz, I_{DD}(DC)=250mA

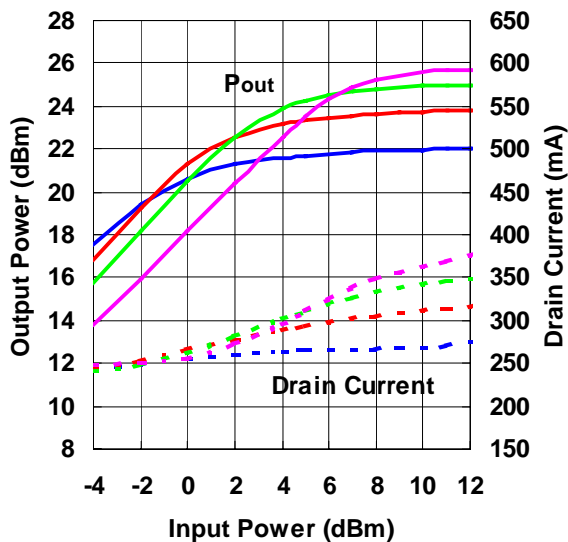

— 3V — 4V — 5V — 6V

Output Power, Drain Current vs. Input Power by Drain Voltage @ freq.=30GHz, I_{DD}(DC)=250mA

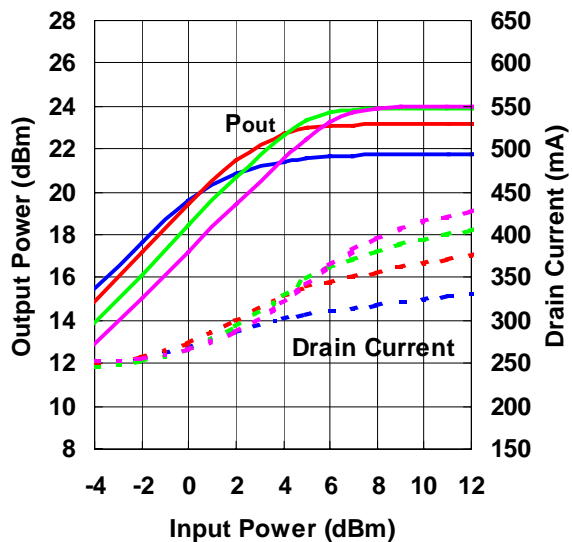

— 3V — 4V — 5V — 6V

ES/FMM5804YD
K,Ka-Band Power Amplifier MMIC

P1dB, G1dB vs. Drain Current
 @ freq.=17.5GHz, VDD=6V

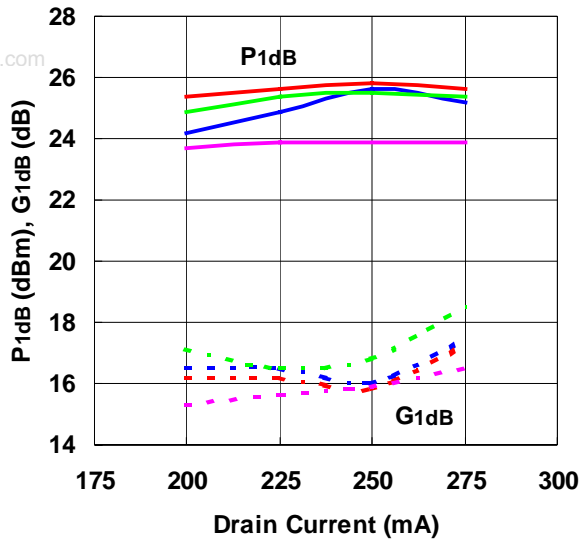

P1dB, G1dB vs. Drain Voltage
 @ freq.=22GHz, IDD(DC)=250mA

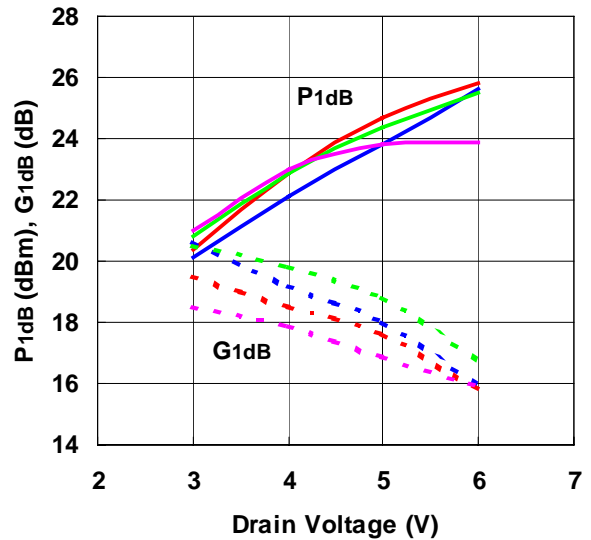

— 17.5GHz — 22GHz — 26GHz — 30GHz

— 17.5GHz — 22GHz — 26GHz — 30GHz

ES/FMM5804YD

K, Ka-Band Power Amplifier MMIC

IMD Performance vs. Total Output Power by Drain Current
@ freq.=17.5GHz, VDD=6V
 $\Delta f=+10\text{MHz}$, 2-tone test

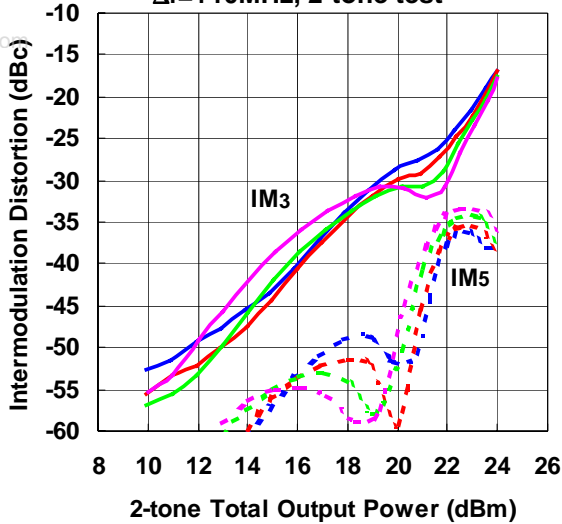

— 200mA — 225mA — 250mA — 275mA

IMD Performance vs. Total Output Power by Drain Current
@ freq.=22GHz, VDD=6V
 $\Delta f=+10\text{MHz}$, 2-tone test

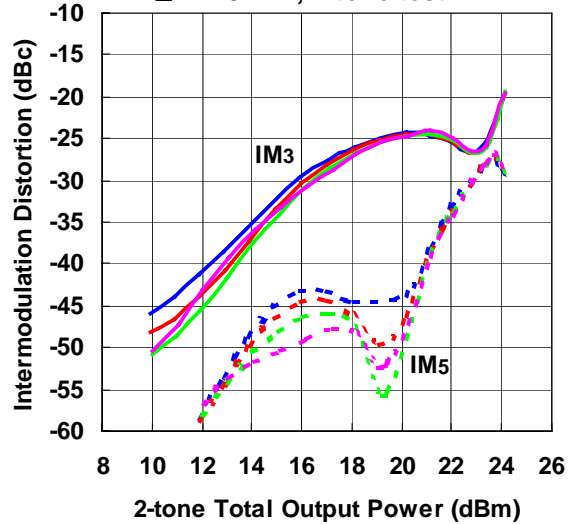

— 200mA — 225mA — 250mA — 275mA

IMD Performance vs. Total Output Power by Drain Current
@ freq.=26GHz, VDD=6V
 $\Delta f=+10\text{MHz}$, 2-tone test

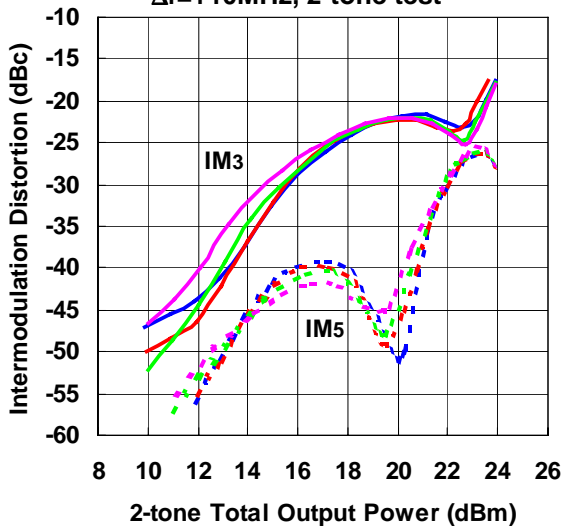

— 200mA — 225mA — 250mA — 275mA

IMD Performance vs. Total Output Power by Drain Current
@ freq.=30GHz, VDD=6V
 $\Delta f=+10\text{MHz}$, 2-tone test

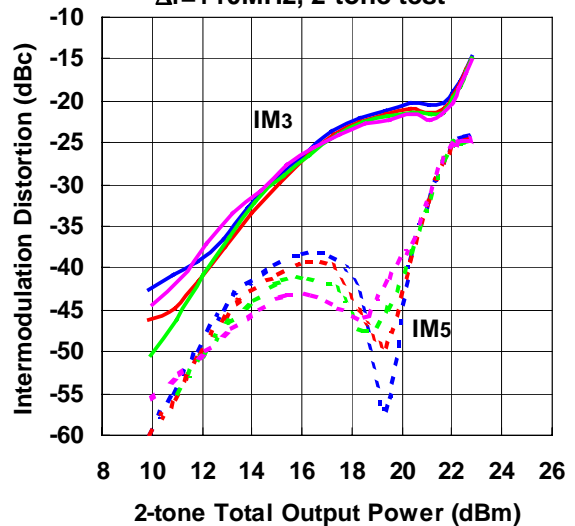

— 200mA — 225mA — 250mA — 275mA

ES/FMM5804YD

K,Ka-Band Power Amplifier MMIC

IMD Performance vs. Total Output Power by Drain Voltage
 @ freq.=17.5GHz, I_{DD}(DC)=250mA
 Δf=+10MHz, 2-tone test

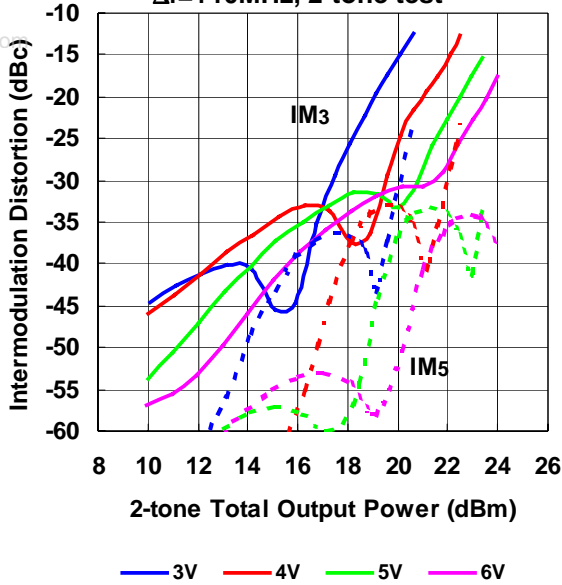

IMD Performance vs. Total Output Power by Drain Voltage
 @ freq.=22GHz, I_{DD}(DC)=250mA
 Δf=+10MHz, 2-tone test

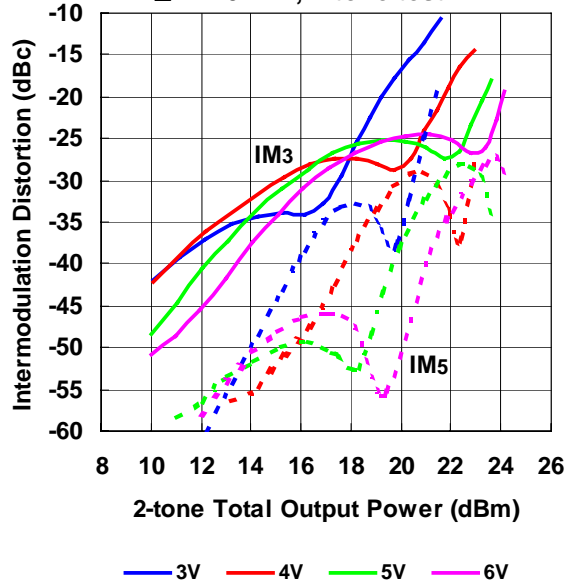

IMD Performance vs. Total Output Power by Drain Voltage
 @ freq.=26GHz, I_{DD}(DC)=250mA
 Δf=+10MHz, 2-tone test

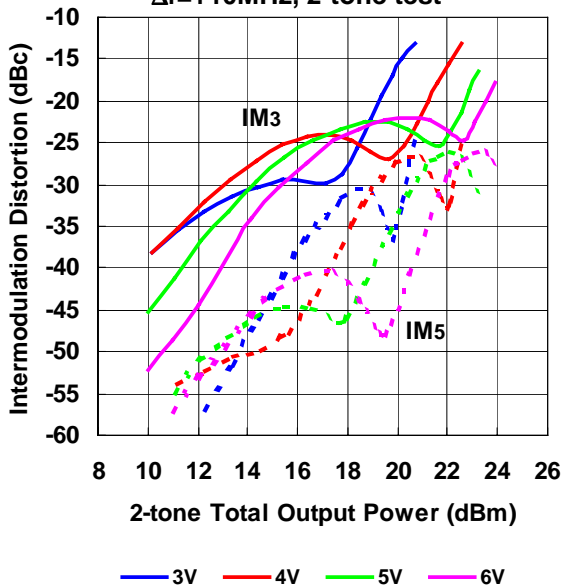

IMD Performance vs. Total Output Power by Drain Voltage
 @ freq.=30GHz, I_{DD}(DC)=250mA
 Δf=+10MHz, 2-tone test

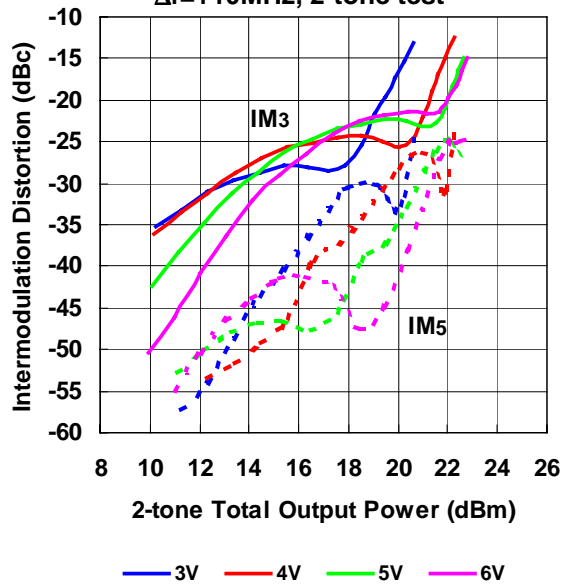

ES/FMM5804YD

K, Ka-Band Power Amplifier MMIC

Small Signal Gain vs. Frequency
@ VDD=6V, IDD(DC)=250mA

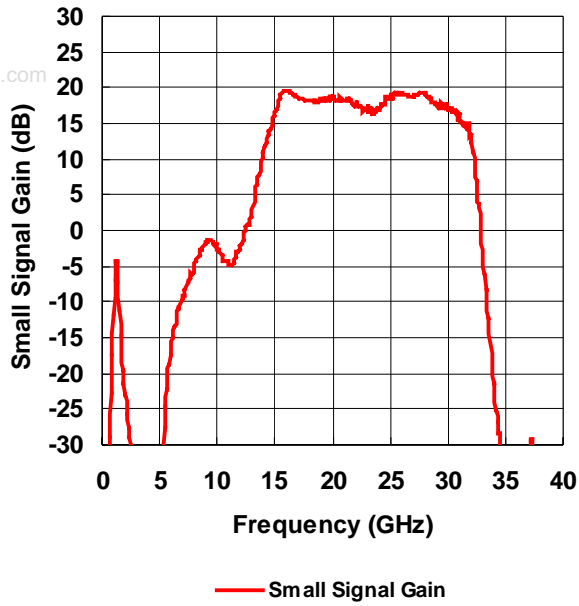

Return Loss vs. Frequency
@ VDD=6V, IDD(DC)=250mA

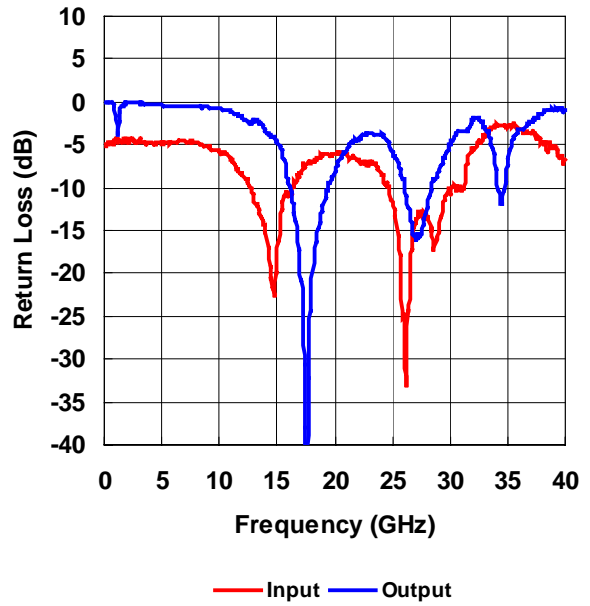

ES/FMM5804YD

K,Ka-Band Power Amplifier MMIC

■ S-Parameters

@ V_{DD}=6V, I_{DD(DC)}=250mA

FREQ. [MHz]	S11		S21		S12		S22	
	mag.	ang.	mag.	ang.	mag.	ang.	mag.	ang.
1000	0.607	141.1	0.258	5.5	0.001	-120.2	0.835	-87.5
2000	0.583	100.0	0.070	-4.1	0.000	129.0	0.994	-130.4
3000	0.591	54.5	0.028	-62.0	0.001	-24.5	0.999	172.2
4000	0.577	10.3	0.022	-72.4	0.004	-23.9	0.974	121.5
5000	0.574	-30.7	0.016	-78.4	0.004	-51.4	0.959	71.8
6000	0.582	-70.4	0.154	-94.9	0.005	-72.3	0.947	23.2
7000	0.590	-105.6	0.347	170.6	0.005	-87.7	0.944	-24.5
8000	0.575	-138.3	0.554	84.9	0.006	-94.3	0.947	-68.5
9000	0.552	-169.3	0.820	-2.6	0.005	-107.6	0.938	-109.2
10000	0.506	164.9	0.761	-87.0	0.005	-65.6	0.917	-145.6
11000	0.460	137.2	0.601	-137.9	0.007	-88.3	0.879	-179.5
12000	0.374	109.7	0.771	-169.9	0.007	-103.3	0.809	148.8
13000	0.274	85.5	1.366	142.2	0.009	-95.3	0.790	119.8
14000	0.172	73.4	3.505	73.6	0.007	-99.8	0.681	82.7
15000	0.129	137.6	6.838	-16.2	0.010	-113.4	0.587	46.5
16000	0.290	98.6	9.513	-125.7	0.006	-67.6	0.340	0.8
17000	0.390	68.6	8.599	143.0	0.009	-118.1	0.105	-42.2
18000	0.449	39.5	8.189	63.0	0.006	-102.4	0.084	103.9
19000	0.496	8.2	8.098	-14.0	0.006	-100.4	0.249	66.2
20000	0.503	-24.1	8.316	-93.7	0.007	-99.9	0.397	29.7
21000	0.483	-54.8	8.051	-172.5	0.008	-100.8	0.533	-9.8
22000	0.462	-85.4	7.427	108.2	0.008	-113.5	0.607	-50.5
23000	0.464	-113.8	6.774	32.2	0.009	-149.0	0.662	-89.5
24000	0.378	-145.3	7.104	-36.3	0.006	153.5	0.646	-128.7
25000	0.253	176.0	8.354	-118.1	0.010	46.2	0.506	-179.5
26000	0.057	138.3	9.016	153.5	0.016	7.6	0.345	127.0
27000	0.212	-137.3	8.667	65.2	0.023	-30.1	0.156	82.8
28000	0.209	142.8	9.179	-29.5	0.024	-62.7	0.241	19.3
29000	0.174	62.2	7.605	-126.1	0.018	-65.0	0.393	-42.8
30000	0.287	-24.6	7.114	125.1	0.026	-86.9	0.564	-80.9
31000	0.307	-65.9	6.564	9.4	0.021	-130.5	0.673	-121.1
32000	0.532	-91.7	4.711	-141.2	0.003	-117.6	0.792	-148.9
33000	0.630	-115.8	0.696	59.2	0.018	-50.9	0.712	163.0
34000	0.739	-147.1	0.085	-59.4	0.021	-103.4	0.402	91.2
35000	0.732	-171.0	0.015	-153.7	0.018	-158.0	0.424	-85.2
36000	0.700	170.6	0.019	100.1	0.014	90.6	0.694	-149.9
37000	0.657	148.5	0.030	0.6	0.015	-1.4	0.764	-177.9
38000	0.581	132.1	0.022	-53.3	0.016	-38.7	0.858	158.4
39000	0.545	118.6	0.005	-38.3	0.013	-56.7	0.909	135.9
40000	0.464	97.9	0.013	-64.6	0.010	-63.0	0.887	114.4

www.DataSheet4U.com

ES/FMM5804YD

K, Ka-Band Power Amplifier MMIC

■ Package Outline

www.DataSheet4U.com

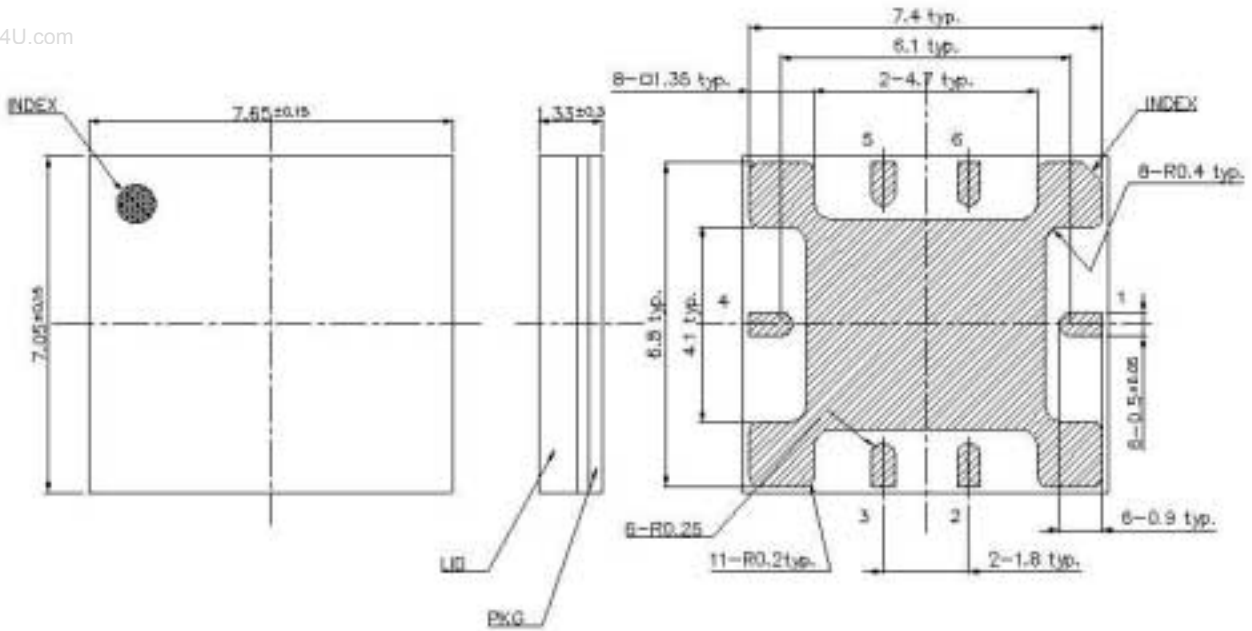

Pin Assignment

- 1 : RF-in
- 2 : VDD1
- 3 : VDD2
- 4 : RF-out
- 5 : VGG
- 6 : N.C.

ES/FMM5804YD

K,Ka-Band Power Amplifier MMIC

■ Block Diagram and External Component

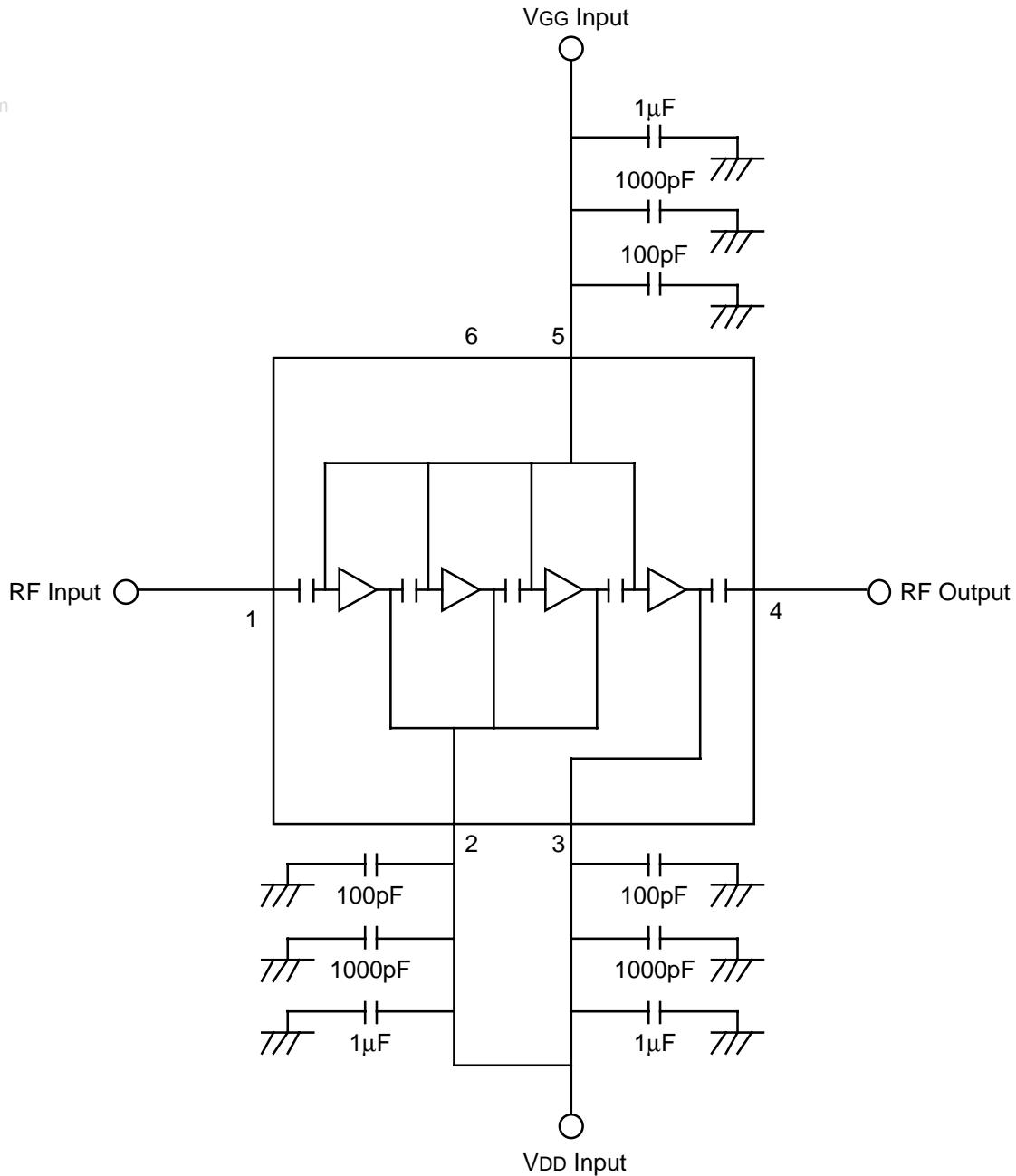

Note) : The capacitors are recommended on the bias supply line, close to the package, in order to prevent video oscillations which could damage the module.



ES/FMM5804YD

K, Ka-Band Power Amplifier MMIC

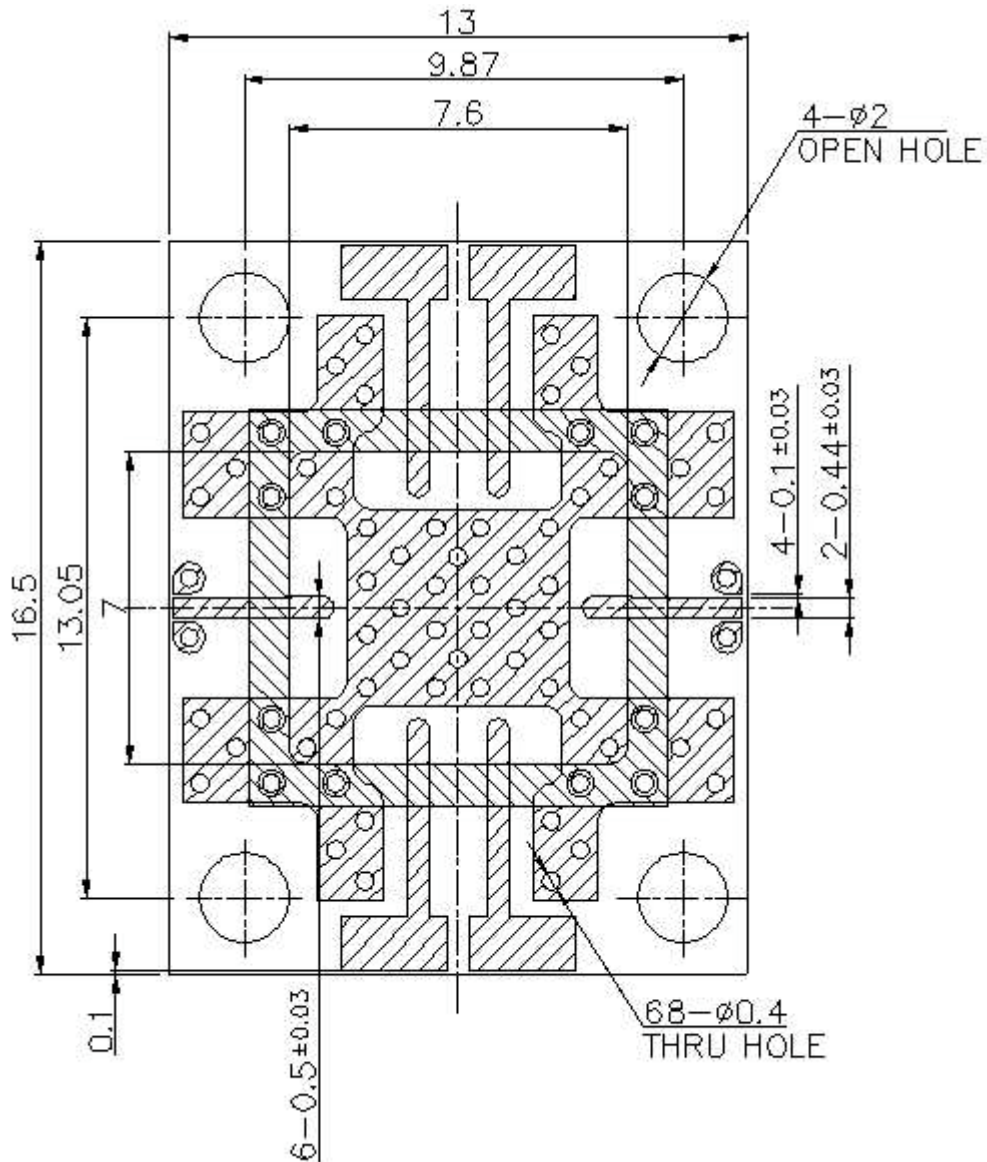
■ Recommended Foot Pattern Layout



Notes :

- 1.LAMINATE : Rogers Corporation RO4003, Thickness $t=0.2\text{mm}$, Cu Foil $18\ \mu\text{m}$
2.  : Finish to copper foil ; Ni $0.1\ \mu\text{m}$ min./Au $0.1\pm 0.08\ \mu\text{m}$ (Both side)
3.  : Resist

Eudyna

ES/FMM5804YD
K,Ka-Band Power Amplifier MMIC

For further information please contact :

Eudyna Devices USA Inc.

2355 Zanker Rd.
San Jose, CA 95131-1138, U.S.A.
TEL: +1 408 232-9500
FAX: +1 408 428-9111

Eudyna Devices Europe Ltd.

Network House
Norreys Drive
Maidenhead, Berkshire SL6 4FJ
United Kingdom
TEL: +44 (0) 1628 504800
FAX: +44 (0) 1628 504888

Eudyna Devices International Srl

Via Teglio 8/2 - 20158
Milano, Italy
TEL: +39-02-8738-1695

Eudyna Devices Asia Pte. Ltd.

Hong Kong Branch
Suite 1906B, Tower 6, China Hong Kong City
33 Canton Road, Tsimshatsui, Kowloon
Hong Kong
TEL: +852-2377-0227
FAX: +852-2377-3921

Eudyna Devices Inc.

1000 Kamisukiahara, showa-cho
Nakakomagun, Yamanashi
409-3883, Japan
(Kokubo Industrial Park)
TEL +81-55-275-4411
FAX +81-55-275-9461

Sales Division

1, Kanai-cho, Sakae-ku
Yokohama, 244-0845, Japan
TEL +81-45-853-8156
FAX +81-45-853-8170

CAUTION

Eudyna Devices Inc. products contain **gallium arsenide (GaAs)** which can be hazardous to the human body and the environment. For safety, observe the following procedures:

- Do not put these products into the mouth.
- Do not alter the form of this product into a gas, powder, or liquid through burning, crushing, or chemical processing as these by-products are dangerous to the human body if inhaled, ingested, or swallowed.
- Observe government laws and company regulations when discarding this product. This product must be discarded in accordance with methods specified by applicable hazardous waste procedures.

Eudyna Devices Inc. reserves the right to change products and specifications without notice. The information does not convey any license under rights of Eudyna Devices Inc. or others.

© 2005 Eudyna Devices Inc.