

PRODUCT SPECIFICATION

2.6" a-Si TFT LCD MODULE MODEL: ET013-A1 Ver:1.1

< ◇ > Preliminary Specification

< ◆ > Finally Specification

CUSTOMER'S APPROVAL	
CUSTOMER :	
SIGNATURE:	DATE:

APPROVED BY	PM REVIEWED	PD REVIEWED	PREPARED By
冯学亮 2010.1.13	邓臣德 2010.1.13	/	张天

Revision Status

Version	Revise Date	Page	Content	Modified By
Ver1.0	2009-12-22		First Issued	
Ver1.0	2010-01-13		Changed the PIN	

Table of Contents

No.	Contents	Page
1.	GENERAL DESCRIPTION	4
2.	MODULE PARAMETERS	4
3.	ELECTRICAL SPECIFICATIONS	4
4.	TERMINAL FUNCTIONS AND BLOCK DIAGRAM	7
5.	OUTLINE DRAWING	8
6.	RELIABILITY SPECIFICATION	9
7.	PRECAUTIONS FOR USE	9
8.	PACKAGE	10

1. General Description

The specification is a transmissive type color active matrix liquid crystal display (LCD) which uses amorphous thin film transistor (TFT) as switching devices. This product is composed of a TFT-LCD panel, driver lcs ,a touch panel and a backlight unit.

2. Module Parameters

No.	Item	Specification	Unit
1	Panel Size	2.6"	inch
2	Number of Pixels	240 RGB x 320	pixels
3	Active Area	38.88(H) x 51.84(V)	mm
4	Pixel Pitch	0.18(W)x0.18(H)	mm
5	Outline Dimension	46.00(W) × 64.00 (H) × 3.4(T)	mm
6	Number of Colors	262k	-
7	Pixel Arrangement	RGB Vertical Stripe	-
8	Display Mode	Normally White TN Tranmissive	-
9	Brightness	200 (Typ.)	cd/m ²
10	Contrast Ratio	120(Typ.)	-
11	Response time (Tr+Tf)	25(Typ.)	ms
12	Viewing Direction	6 o'clock	-
13	Input Interface	16-bits or 8-bits bus interface	-
14	Viewing Angle (H/V)	45/45 (H) ; 15/35 (V)	degree
15	Backlight unit	White(4 LED) / parallel	-
16	Surface Treatment	Normal	-
17	Driver IC	HX8347D	-
18	Weight	TBD	g

3. Electrical Specifications

3-1 Absolute Maximum Ratings

(Ta = 25 °C)

Item	Symbol	Values		Unit	Remark
		Min	Max.		
	VDD	-0.3	3.0	V	GND=0
Input signal voltage	Vin	-0.5	VDD+0.3	V	
LED Forward Voltage	V _F	3.2		V	One LED (IF=20mA)
LED Forward Current	IF	20		mA	One LED
Operating Temperature	Top	-20	70	°C	
Storage Temperature	Tst	-30	80	°C	

3-2 DC Characteristics

Item	Symbol	Values			Unit	Remark
		Min	Typ	Max.		
Operating voltage	IOVDD	2.6	2.8	3.0	V	
Input high voltage	V _{IH}	0.8 VDD	-	VDD	V	
Input low voltage	V _{IL}	-0.3	-	0.2 VDD	V	
Current Consumption	I _{VCI}	-	-	-	mA	VDD=2.8V

3-3. Backlight Characteristics

Item	Symbol	Values			Unit	Remark
		Min	Typ	Max.		
Power Supply Voltage	VF	3.0	3.2	3.3	V	Note1
Power Supply Current	IF	-	60	-	mA	
Power Consumption	P _{LED}	-	192	-	mW	

Note: LEDs should be always be driven by an external constant current source

3-4. Optical Characteristics

Item	Symbol	Condition	Min.	Typ.	Max.	Unit	Remark	
Brightness	L _v		150	200	-	cd/m ²	Note5	
Contrast Ratio	CR	At optimized viewing angle	100	120	-	-	Note4	
Response time	Tr+Tf	θ=0	-	25	40	ms	Note3	
Viewing Angle	Top	φ _H	Center CR ≥ 10	10	15	-	degree	Note2
	Bottom	φ _L		30	35	-		
	Left	θ _L		40	45	-		
	Right	θ _R		40	45	-		
Color Coordinate	White	X _w	Viewing normal angle φ, θ=0	-	0.314	-	-	-
		Y _w		-	0.334	-		
	Red	X _R		-	0.571	-		
		Y _R		-	0.352	-		
	Green	X _G		-	0.345	-		
		Y _G		-	0.557	-		
	Blue	X _B		-	0.148	-		
Y _B		-	0.128	-				
Uniformity	Un		80	85	-	%	-	

Note.1: After stabilizing and leaving the panel alone at a given temperature for 30 minutes, the measurement should be executed. Measurement should be executed in a stable, windless, and dark room. Optical specifications are measured by Topcon BM-7(fast) with a viewing angle of 1° at a distance of 50cm and normal direction.

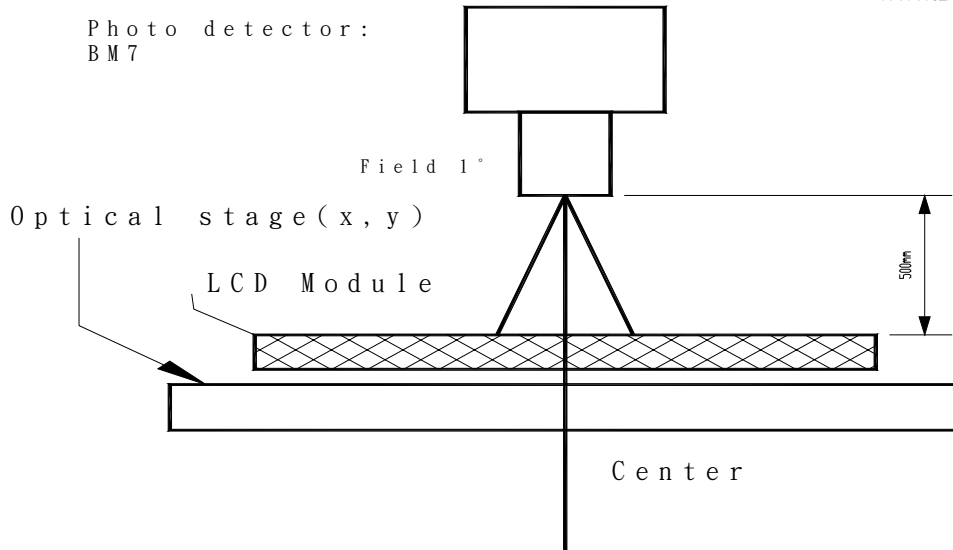

Note.2: Definition of Viewing Angle: Refer to figure as below:

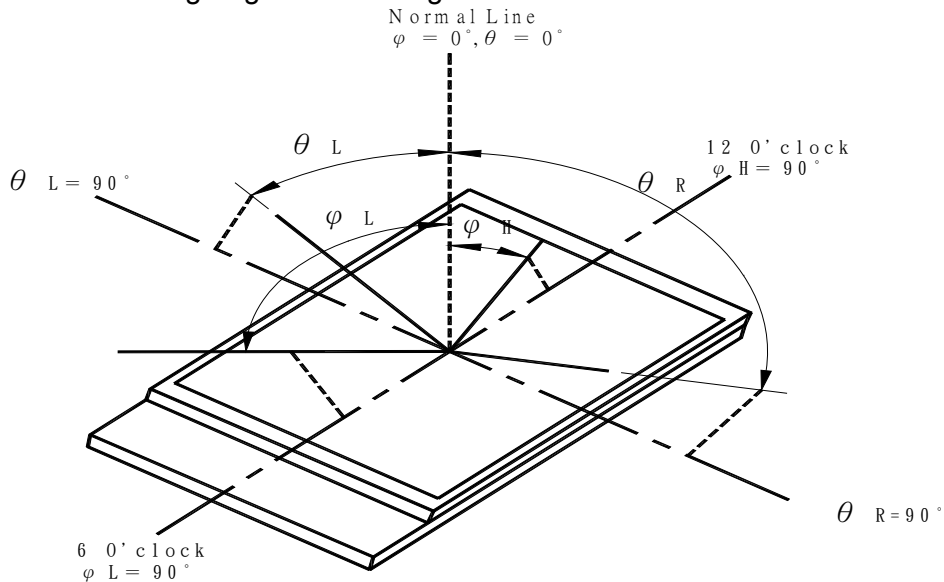

Note.3: Definition of Response Time: TR and TF

The figure below is the output signal of the photo detector.

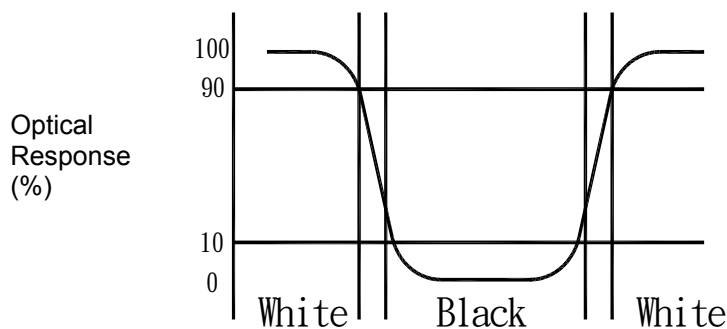

Note.4: Definition of Contrast Ratio (CR)

Ratio of gray max (G max)& gray min(G min)

Contrast ratio (CR) =(G max) / (G min)

(G max)=luminance with all pixel white

(G min)=luminance with all pixel black

Note.5: Measured at the center area of the panel when all the input terminals of LCD panel are electrically opened.

4. Terminal Functions and Block Diagram

4-1 Interface Pin Function Description

No.	Symbol	Function	Remark
1~4	DB0~DB3	Data Bus DB0~DB3	
5	GND	Ground	
6	VCC	Logic supply power	
7	CS/	Chip select signal (Low: active)	
8	RS	Data/Commander selection	
9	/WR	Write	
10	/RD	Read	
11	IMO	Select the MPU interface mode	
12	YD	Touch screen terminal	
13	XR	Touch screen terminal	
14	YU	Touch screen terminal	
15	XL	Touch screen terminal	
16	LED+	LED anode	
17~20	LEDK1~LEDK4	LED cathode 1~4	
21	FMARK	Output a frame head pulse signal	
22	DB4	Data Bus DB4	
23~30	DB8~DB15	Data Bus DB8~DB15	
31	/RESET	Reset	
32	VCI	Logic supply power	
33	IOVCC	Logic supply power	
34	GND	Ground	
35~37	DB5~DB7	Data Bus DB5~DB7	

4-2 Block Diagram

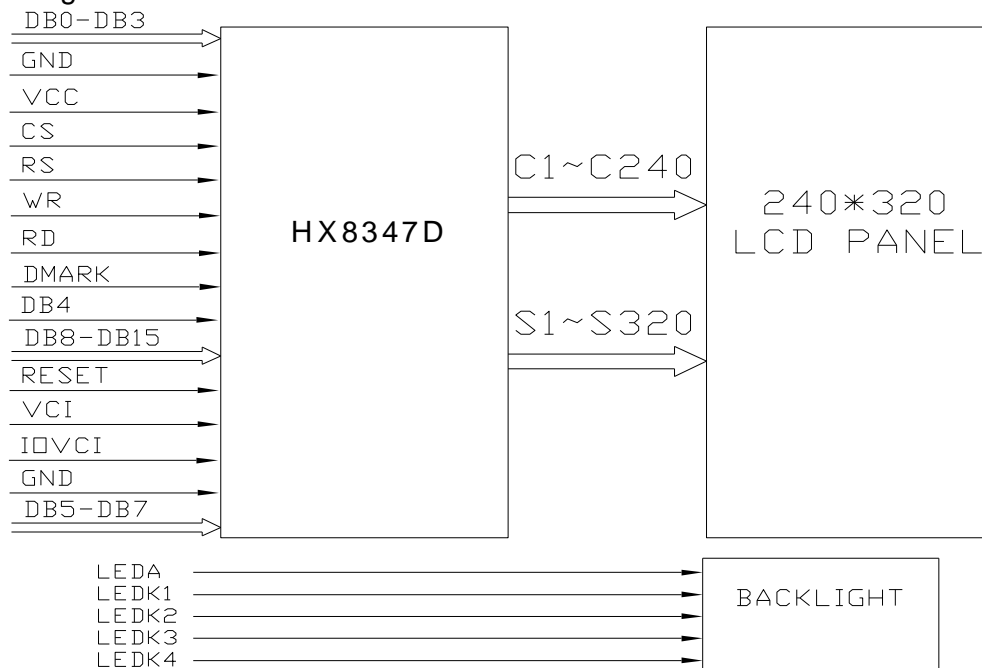

5. Outline Drawing

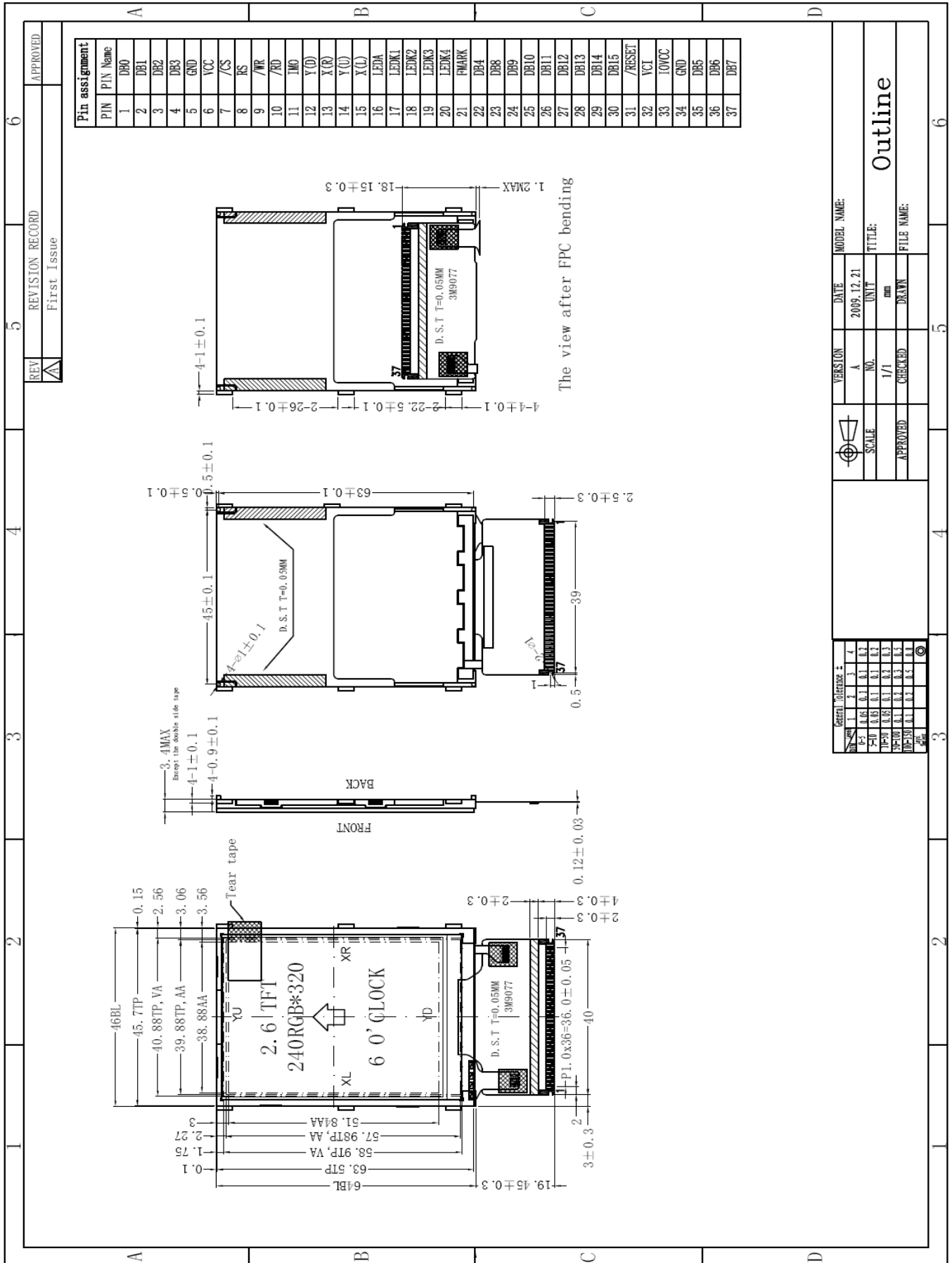

REVISION RECORD	APPROVED	
REV	First Issue	
VERSION	DATE	MODEL NAME:
A	2009.12.21	
NO.	UNIT	TITLE:
1/1	mm	Outline
CHECKED	DRAWN	FILE NAME:
APPROVED		

General Tolerance ±				
ITEM	1	2	3	4
D-F	0.05	0.1	0.1	0.2
F-H	0.05	0.1	0.1	0.2
I-P	0.05	0.1	0.2	0.3
Q-R	0.1	0.1	0.2	0.5
S-V	0.1	0.1	0.2	0.4
W-X	0.1	0.1	0.2	0.4
Y-Z	0.1	0.1	0.2	0.4
ALL				

6. Reliability Specification

NO.	Item	Condition	Criterion
1	High Temperature Operating	70°C, 48Hrs	No defect in cosmetic and operational function allowable. Total current Consumption should be below double of initial value.
2	Low Temperature Operating	-20°C, 48Hrs	
3	High Humidity	50°C, 90%RH, 48Hrs	
4	High Temperature Storage	80°C, 48Hrs	
5	Low Temperature Storage	-30°C, 48Hrs	
6	Thermal shock	-20°C, 30min~70°C, 30min, 10 cycles.	

Note: 1) Above conditions are suitable for our company standard products.

2) For restrict products, the test conditions listed as above must be revised.

7. Precautions for Use

7.1 Safety

- (1) Do not swallow any liquid crystal, even if there is no proof that liquid crystal is poisonous.
- (2) If the LCD panel breaks, be careful not to get liquid crystal to touch your skin.
- (3) If skin is exposed to liquid crystal, wash the area thoroughly with alcohol or soap.

7.2 Storage Conditions

- (1) Store the panel or module in a dark place where the temperature is $23\pm 5^{\circ}\text{C}$ and the humidity is below $50\pm 20\%\text{RH}$.
- (2) Store in anti-static electricity container.
- (3) Store in clean environment, free from dust, active gas, and solvent.
- (4) Do not place the module near organics solvents or corrosive gases.
- (5) Do not crush, shake, or jolt the module.

7.3 Handling Precautions

- (1) Avoid static electricity which can damage the CMOS LSI.
- (2) The polarizing plate of the display is very fragile. So, please handle it very carefully.
- (3) Do not give external shock.
- (4) Do not apply excessive force on the surface.
- (5) Do not wipe the polarizing plate with a dry cloth, as it may easily scratch the surface of plate.
- (6) Do not use ketonics solvent & Aromatic solvent, use with a soft cloth soaked with a cleaning naphtha solvent.
- (7) Do not operate it above the absolute maximum rating.
- (8) Do not remove the panel or frame from the module.

7.4 Warranty

The period is within twelve months since the date of shipping out under normal using and storage conditions.

8. Package

TBD