

3 CHANNEL DIFFERENTIAL AMPLIFIER-COMPARATOR

(Lower hysteresis version of standard ET9570)

www.DataSheet4U.com
ET9570LH

FEATURES

- Supply Voltage Range 4.5V to 30V
- Operation to 1MHz
- Designed for photodiode inputs
- Index gated by A and B channels
- Current sink for LED drive (see application note

APP-D2)

- Outputs short circuit protected
- 25mA peak drive current
- Comparator hysteresis only 1.1 : 1

APPLICATIONS

- High Speed Optical Encoders
- Industrial Controls

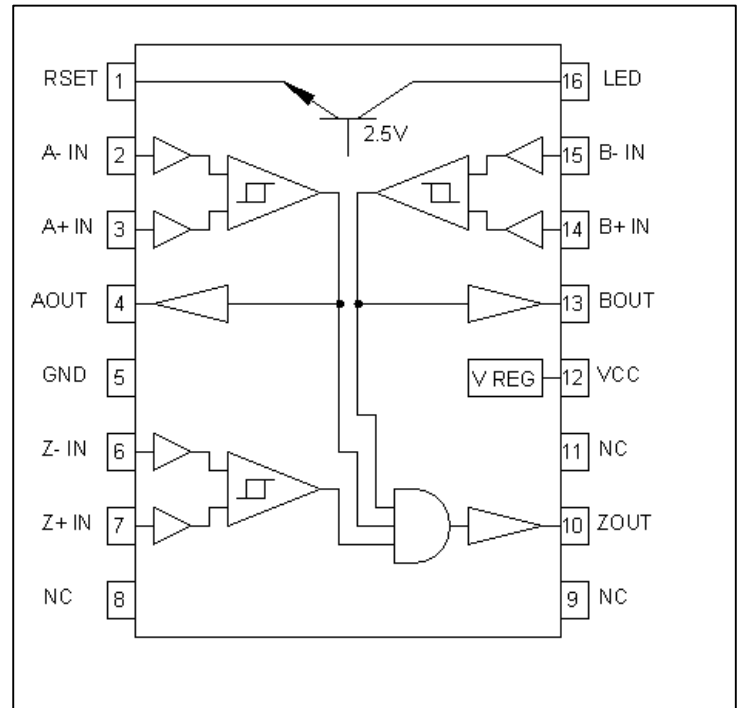

DESCRIPTION

These devices are specifically designed as receiver circuits for the photodiode signals available in optical encoders. Connect the anode of the photodiodes to the input pins, with the cathode(s) connected to Vcc for reverse-bias operation. The input amplifiers have a dynamic range of nearly 1000:1, and allow contrast ratios of encoded signal to common mode signal of as low as 2:1. Differential inputs enhance noise rejection and performance over temperature. Gating of the Z channel provides synchronization of the reference pulse to the data channel phasing. Hysteresis ratio of comparators is 1.1:1, instead of the 1.25:1 on the standard device.

ABSOLUTE MAXIMUM RATINGS

Parameter	Symbol	Min.	Max.	Units	Ref.
Operating Temperature Range	T _A	-40	125	°C	Note 1
Supply Voltage Range	V _{CC}	4.5	30	V	

ETIC RESERVES THE RIGHT TO MAKE CHANGES AT ANY TIME TO IMPROVE THE DESIGN AND TO SUPPLY THE BEST PRODUCT.

ELECTRICAL CHARACTERISTICS

Unless otherwise specified, typical values given at $V_{CC}=12V$, $T_A = 25^{\circ}C$, with LED and RSET open.

Parameters	Symbol	Min.	Typ.	Max.	Units	Test Conditions
Supply Current	I _{CC1}	4.5	7.2	11.5	mA	V _{CC} = 4.5 V
	I _{CC2}	5.0	8.0	12.5		V _{CC} = 30.0V
Input Common Mode Voltage	V _{CM}		1.35		V	
Average Photocurrent Input	I _{IA}	0.066	0.3	40	μA	Each input
Peak Photocurrent Input	I _{IP}	0.13	0.5	60	μA	Each input
Dark Cell Level	I _{ID}	0.02	0.1	20	μA	Each input
Photocurrent Contrast Ratio	I _{IR}	2:1	5:1			Peak:Dark Cell
Comparator Threshold			1.1:1			Ratio of Differential Inputs
Output High Level Voltage	V _{OH}	2.5 28.0	3.0 28.5		V	I _{OH} = -4mA, V _{CC} = 4.5V I _{OH} = -4mA, V _{CC} = 30V
Output Low Level Voltage	V _{OL}		199	400	mV	V _{CC} = 4.5V-30V I _{OL} = 8mA
Output Short-Circuit Current Driving High (All Outputs)	I _{OS}	15	25	50	mA	V _{CC} = 5V, V _{OUT} = 0V
Output Short-Circuit Current Driving Low (All Outputs)	I _{OS}	30	70	120	mA	V _{CC} = 5V, V _{OUT} = 5V
RSET Voltage	V _{RSET}	1.3	1.7	2.1	V	R = 180 ohms

AC SWITCHING CHARACTERISTICS

Values given at $V_{CC} = 5V$, $T_A = 25^{\circ}C$, $C_L = 15pF$ on all outputs.

Parameters	Symbol	Min.	Typ.	Max	Units	Test Conditions
Pre-Amplifier Bandwidth	BW _{PA}		900		KHz	Photocurrent = 1μA Minimum
Propagation delay from Comparator Input to Output	T _{PD}		850		ns	
Output Rise Time	T _R		100		ns	
Output Fall Time	T _F		20		ns	

NOTES:

www.DataSheet4U.com

- This is not a test parameter, but for information only.

PACKAGE

Chip Only
16 Lead SOIC

SUFFIX

-C
-SOP

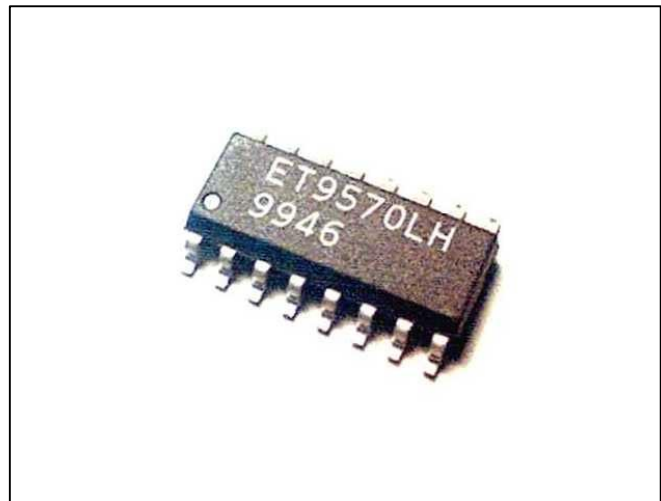

ETIC RESERVES THE RIGHT TO MAKE CHANGES AT ANY TIME TO IMPROVE THE DESIGN AND TO SUPPLY THE BEST PRODUCT.

© 2000, Rev A1

iC-Haus GmbH

Integrated Circuits

Am Kuemmerling 18, D-55294 Bodenheim

Tel +49-6135-9292-0

Fax +49-6135-9292-192

http://www.ichaus.com