

2A, 22V Step-Up Regulator

DESCRIPTION

The ETA1611 is a high efficiency step-up converter with an internally integrated 22V power MOSEFT. It runs with an optimal 1MHz frequency that enables the use of small external components while still providing the best efficiency. It can drive up to 2A output current. The incorporated true PWM-Dimming feature through EN pin enable one further digitally program the output voltage lower. For maximum protection, the ETA1611 has an OVP protection feature that prevents the output voltage exceeding the maximum rating of the ETA1611 and the output cap during open conditions.

ETA1611 is available in a space-saving SOT23-6 package.

FEATURES

- **Up to 95% Efficiency**
- **22V OVP protection**
- **True PWM Brightness Control**
- **200mV Feedback Voltage**
- **2.8A current limit**
- **SOT23-6 Package**

APPLICATIONS

- Portable power bank
- Powering 3G module
- Large LCD display backlight driving up to 90 LEDs
- Satellite STB
- Bluetooth Speaker
- Large TFT screen bias
- Other application which needs high voltage and high current generation

TYPICAL APPLICATION

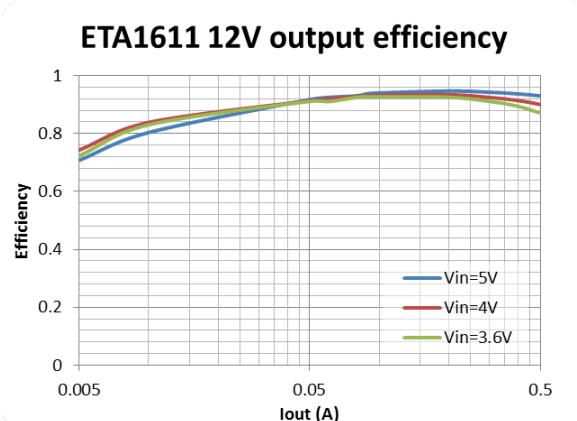
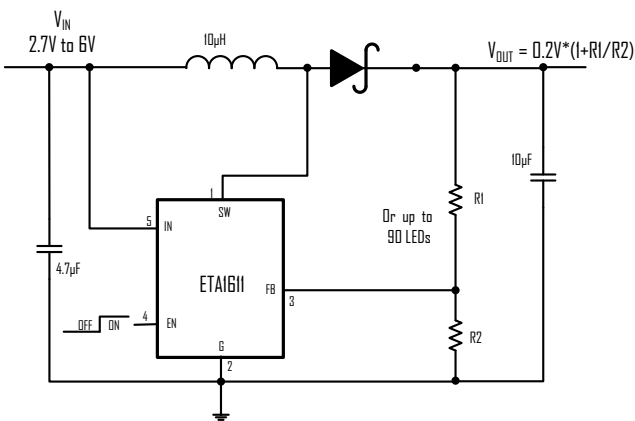

ORDERING INFORMATION

PART No.	PACKAGE	TOP MARK	Pcs/Reel
ETA1611S2G	SOT23-6	GVY <u>W</u>	3000

PIN CONFIGURATION

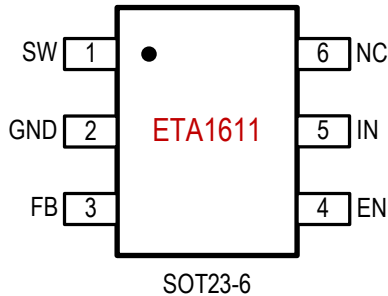

ABSOLUTE MAXIMUM RATINGS

(Note: Exceeding these limits may damage the device. Exposure to absolute maximum rating conditions for long periods may affect device reliability.)

SW Voltage.....	-0.3V to 25V
All Other PIN Voltages.....	-0.3V to 6.5V
SW to ground current	Internally limited
Junction Temperature	150°C
Storage Temperature Range	-55°C to 150°C
Thermal Resistance θ_{JA} θ_{JC}	
SOT23-6.....	134.....50°C/W

Recommended Operating Conditions

(Note: The device is not guaranteed to function outside its operating conditions.)

Ambient Temperature Range	-40°C to 85°C
Junction Temperature Range	-40°C to 125°C

ELECTRICAL CHARACTERISTICS

($V_{IN} = 3.6V$, unless otherwise specified. Typical values are at $T_A = 25^\circ C$.)

PARAMETER	CONDITIONS	MIN	TYP	MAX	UNITS
Input Voltage Range		2.7		6	V
Input UVLO	Rising	2.00	2.32	2.6	V
UVLO HYS			140		mV
FB Feedback Voltage	$V_{IN} = V_{EN} = 3.6V$	194	200	206	mV
FB Input Current				50	nA
Quiescent Current at IN	Switching at $I_{out}=0$		1.8		mA
	No Switching		0.25		mA
Shutdown Supply Current at IN	$V_{EN}=GND$		0	5	μA
Switching Frequency	$V_{IN}<4.3V$	0.8	1	1.2	MHz
Maximum Duty Cycle			90		%
NMOS Switch On Resistance	$I_{SW} = 100mA$		0.1		Ω
NMOS Switch Current Limit			2.8		A
SW Leakage Current	$V_{SW}=0$ or $20V$, $V_{EN}=GND$			10	μA
EN Input Low Voltage				0.6	V
EN Input High Voltage		1.2			V
Thermal Shutdown	Rising, Hysteresis= $10^\circ C$		150		$^\circ C$

PIN DESCRIPTION

PIN #	NAME	DESCRIPTION
1	SW	Inductor Connection. Connect an inductor Between SW and IN.
2	GND	Ground Pin
3	FB	Feedback Input for Current. Connect an external resistor FB to GND to set I_{OUT}
4	EN	Control pin for the IC. It is a multi-functional pin for enable control, PWM dimming. If the pin is floating will disable the IC.
5	IN	Input Supply pin. Bypass with a 4.7 μ F or larger ceramic capacitor to GND
6	NC	Not connected, leave this PIN floating

TYPICAL CHARACTERISTICS

(Typical values are at TA = 25°C unless otherwise specified.)

ETA1611 5V output efficiency

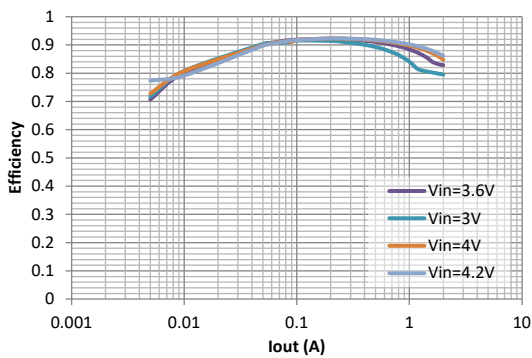

ETA1611 12V output efficiency

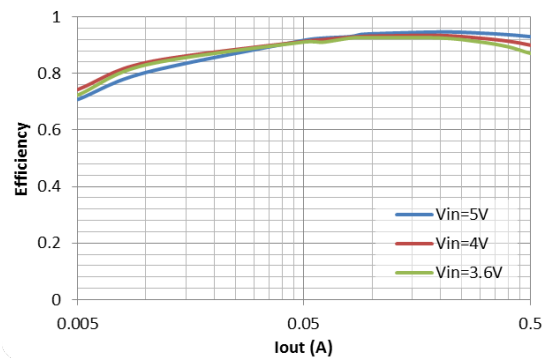

FB Voltage VS PWM Duty Cycle

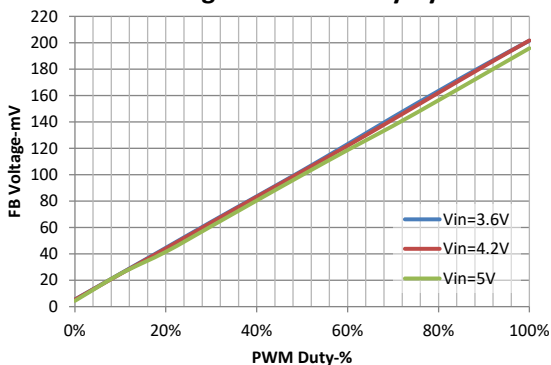

Switch Frequency VS. Supply Voltage

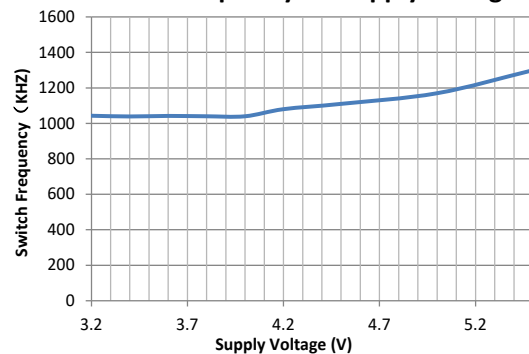

TYPICAL CHARACTERISTICS Cont'd

(Typical values are at TA = 25°C unless otherwise specified.)

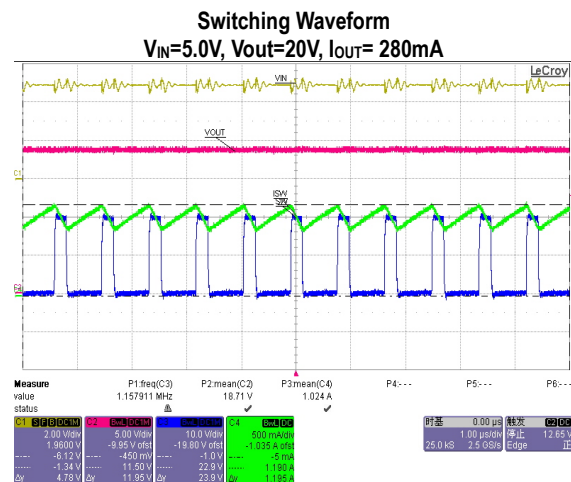
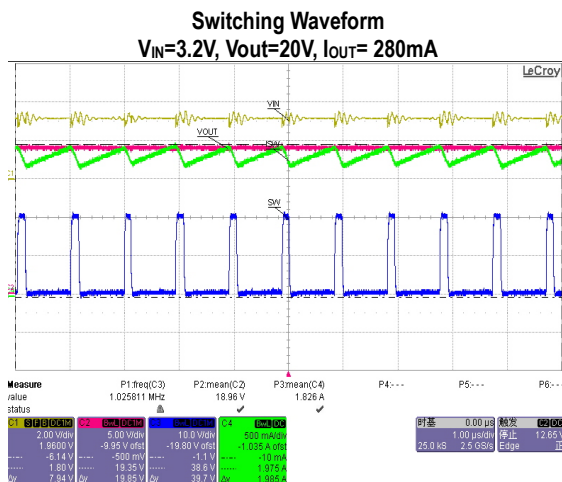

FUNCTIONAL DESCRIPTIONS

The ETA1611 is a high efficiency, high output voltage boost converter in a small package size. The device is ideal for delivering 1-2A current when boosting up the output voltage. The device integrates 22V/2.8A switch FET and operates in pulse width modulation (PWM) with 1MHz fixed switching frequency. For operation details, please check the block diagram at the “Block Diagram” chapter. The duty cycle of the converter is set by the error amplifier output and the current signal applied to the PWM control comparator. The feedback loop regulates the FB pin to a low reference voltage (200mV typical), reducing the power dissipation in the current sense resistor.

Output Open Circuit Protection

Output open circuit protection circuitry prevents IC damage as the result of output open circuit (e.g. LED string absence). The ETA1611 monitors the voltage at the SW pin and FB pin during each switching cycle. The circuitry turns off the switch FET and shuts down the IC when both of the following conditions persist for 8 switching clock cycles: (1) the SW voltage exceeds the VOVP threshold, which is 25V and (2) the FB voltage is less than half of regulation voltage. As a result, the output voltage falls to the level of the input supply. The device remains in shutdown mode until it is enabled by toggling the EN pin logic. The output voltage plus the 200mV reference voltage cannot exceed the minimum OVP threshold or $OUTPUT\ VOLTAGE + 200\ mV \leq VOVP(MIN)$.

Shutdown

The ETA1611 enters shutdown mode when the EN voltage is logic low for more than 2.5ms. During shutdown, the input supply current for the device is less than 1µA (max). Although the internal FET does not switch in shutdown, there is still a DC current path between the input and the output through the inductor and Schottky diode.

For LED driving application, the minimum forward voltage of the LED array must exceed the maximum input voltage to ensure that the LEDs remain off in shutdown. However, in the typical application with two or more LEDs, the forward voltage is large enough to reverse bias the Schottky and keep leakage current low.

ETA1611

Output Voltage Setting

The FB voltage is regulated by a low 0.2V reference voltage. The output voltage is set externally by using a resistor divider. The value of the R1/R2 divider is calculated using Equation 1.1:

$$V_{OUT} = V_{FB}/R_2 \cdot (R_1 + R_2) \quad (1.1)$$

Where

V_{OUT} = output voltage, R_2 = resistance between FB and GND, R_1 = resistance between OUT and FB.

The output current tolerance depends on the FB accuracy and the current sensor resistor accuracy.

LED Driving Current Setting

The FB voltage is regulated by a low 0.2V reference voltage. The LED current is set externally using a current-sense resistor in series with the LED string. The value of the RSET is calculated using Equation 1.2:

$$I_{LED} = V_{FB}/R_{SET} \quad (1.2)$$

Where

I_{LED} = output current of LEDs, R_{SET} = current sense resistor

The output current tolerance depends on the FB accuracy and the current sensor resistor accuracy.

PWM Dimming Control or Output Voltage Programming

When the EN pin is constantly high, the FB voltage is regulated to 200mV typically. However, the EN pin allows a PWM signal to reduce this regulation voltage; therefore, it achieves LED brightness dimming or output voltage programming (only to make output voltage lower). The relationship between the duty cycle and FB voltage is given by Equation 1.3:

$$V_{FB} = \text{Duty} \cdot 200 \text{ mV} \quad (1.3)$$

Where

Duty = duty cycle of the PWM signal, 200 mV = internal reference voltage

This PWM dimming eliminates the audible noise which often occurs when the output current is pulsed in replica of the frequency and duty cycle of PWM control. Unlike other scheme which filters the PWM signal for analog dimming, ETA1611 regulation voltage is independent of the PWM logic voltage level which often has large variations for optimum performance, use the PWM dimming frequency in the range of 25kHz to 100kHz.

APPLICATION INFORMATION

Inductor Selection

Using an inductor with a smaller inductance value forces discontinuous PWM when the inductor current ramps down to zero before the end of each switching cycle. This reduces the boost converter’s maximum output current, causes large input voltage ripple and reduces efficiency. Large inductance value provides much more output current and higher conversion efficiency. For these reasons, a 4.7 μ H to 10 μ H inductor value range is recommended. A 10 μ H inductor optimized the efficiency for most application while maintaining low inductor peak to peak ripple. Below table lists the recommended inductor for the ETA1611.

Recommended Inductors for ETA1611

Part #	L(μ H)	Saturation Current (mA)	Vendor
SWRH3D16S	4.7 - 10	>2500	Sunlord

Schottky Diode Selection

A high-speed rectifying Schottky is recommended for ETA1611 for maximum efficiency due to its high switching frequency. The diode average and peak current rating must be larger than the average output current and peak inductor current to ensure reliability. In addition, the diode’s reverse breakdown voltage must exceed the open LED protection voltage.

Input and Output Capacitor Selection

The output capacitor is mainly selected to meet the requirements for the output ripple and loop stability. The output requires a capacitor in the range of 10 μ F to 22 μ F.

BLOCK DIAGRAM

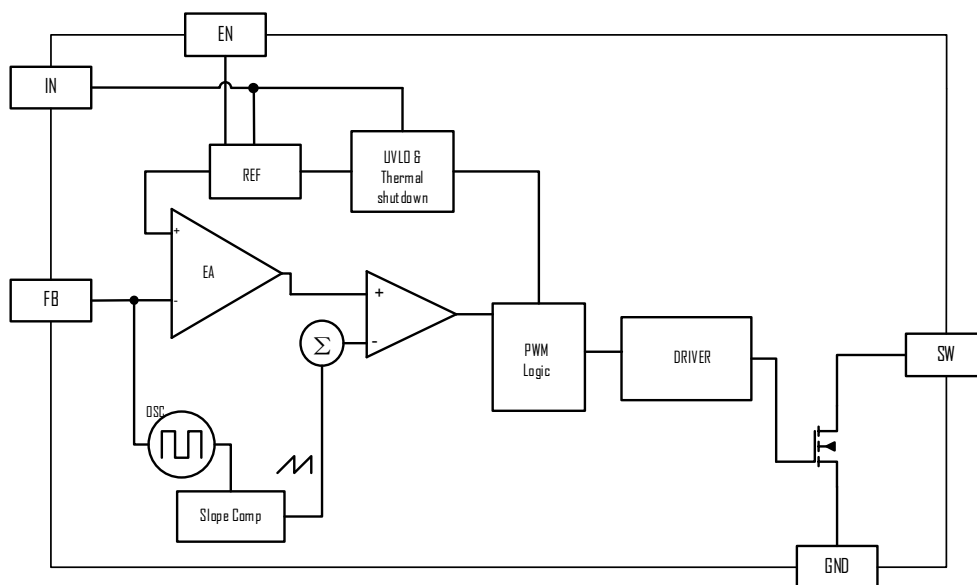

PACKAGE OUTLINE

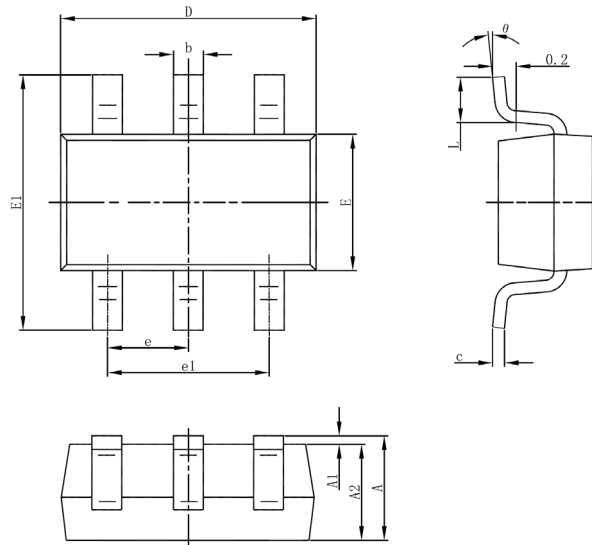

Symbol	Dimensions In Millimeters		Dimensions In Inches	
	Min	Max	Min	Max
A	1.050	1.250	0.041	0.049
A1	0.000	0.100	0.000	0.004
A2	1.050	1.150	0.041	0.045
b	0.300	0.500	0.012	0.020
c	0.100	0.200	0.004	0.008
D	2.820	3.020	0.111	0.119
E	1.500	1.700	0.059	0.067
E1	2.650	2.950	0.104	0.116
e	0.950(BSC)		0.037(BSC)	
e1	1.800	2.000	0.071	0.079
L	0.300	0.600	0.012	0.024
θ	0°	8°	0°	8°