

## 1A, 3MHz Step-Down Converter in SOT563 Package

### DESCRIPTION

The ETA3415 is a high-efficiency, DC to DC step-down switching regulator, capable of delivering up to 1A of output current. The devices operate from an input voltage range of 2.6V to 7V and provide output voltages from 0.6V to VIN, making the ETA3415 ideal for low voltage power conversions. Running at a fixed frequency of 3MHz allows the use of small inductance value and low DCR inductors, thereby achieving higher efficiencies. Other external components, such as ceramic input and output caps, can also be small due to higher switching frequency, while maintaining exceptional low noise output voltages. Built-in EMI reduction circuitry makes this converter ideal power supply for RF applications. Internal soft-start control circuitry reduces inrush current. Short-circuit and thermal-overload protection improves design reliability. ETA3415 is housed in SOT563 and DFN1.6x1.6-6 packages.

### FEATURES

- ◆ Up to 96% Efficiency
- ◆ Up to 1A Max Output Current
- ◆ 3MHz Switching Frequency
- ◆ Light Load operation
- ◆ Internal Compensation
- ◆ SOT563 Package
- ◆ DFN1.6x1.6-6 Package
- ◆ RoHS Compliant

### APPLICATIONS

- ◆ LCD TV
- ◆ Set Top Box
- ◆ IP CAM

### TYPICAL APPLICATION

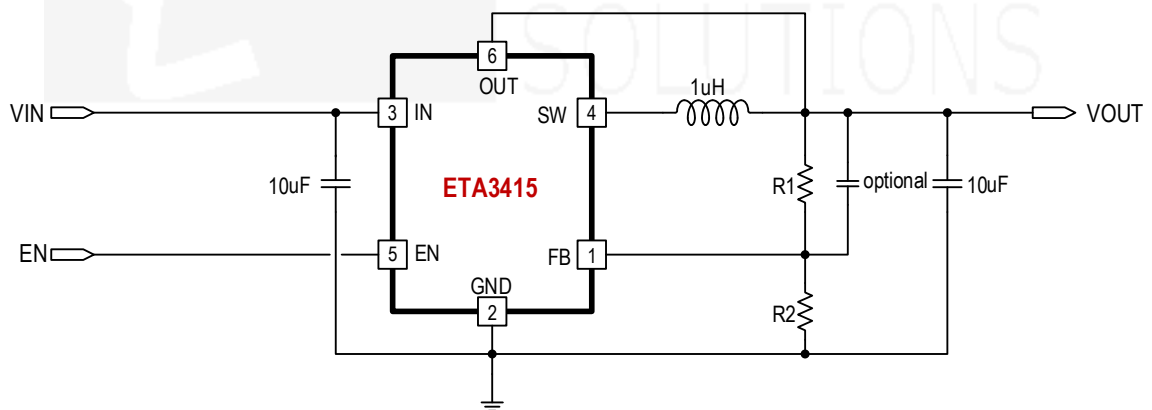

$$V_{out} = \frac{R1+R2}{R2} \times 0.6(V)$$

### ORDERING

PART No.	PACKAGE	TOP MARK	Pcs/Reel
ETA3415S6G	SOT563	IKYW	3000
ETA3415DCG	DFN1.6x1.6-6	IKYW	3000

### INFORMATION

## PIN CONFIGURATION

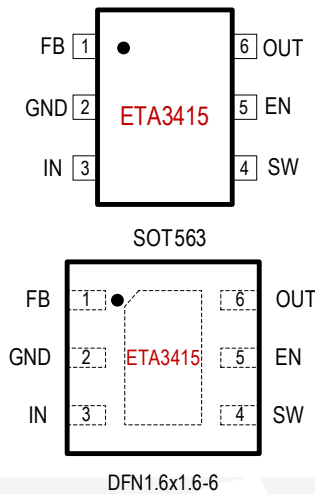

## ABSOLUTE MAXIMUM RATINGS

(Note: Exceeding these limits may damage the device. Exposure to absolute maximum rating conditions for long periods may affect device reliability.)

VIN, EN, SW Voltage .....	9V
FB Voltage.....	6V
Operating Temperature Range .....	-40°C to 85°C
Storage Temperature Range .....	-55°C to 150°C
Thermal Resistance $\theta_{JA}$ $\theta_{JC}$	
SOT563.....	130.....60..... °C/W
DFN1.6x1.6-6.....	46.5.....18.6..... °C/W
Lead Temperature (Soldering 10sec) .....	260°C

## ELECTRICAL CHARACTERISTICS

(VIN = 3.6V, unless otherwise specified. Typical values are at TA = 25°C.)

PARAMETER	CONDITIONS	MIN	TYP	MAX	UNIT
Input Voltage Range		2.6		6.5	V
Input UVLO	Rising, Hysteresis=300mV		2.35	2.45	V
OVP	Rising, Hysteresis=400mV		7		V
Input Supply Current	VFB=0.65V, no switching		20	40	µA
Input Shutdown Current				1	µA
FB Voltage	2.5V ≤ VIN ≤ 5.5V	0.588	0.6	0.612	V
FB Input Current	VFB=1V		0.01		µA
Output Voltage Range		0.6		VIN	V
Load Regulation	VOUT = 1.8V, IOUT from 0.1A to 1A		0.1		%/A
Line Regulation	VIN=2.7V to 5.0V and IOUT=0.5A		0.1		%/V
Switching Frequency			3		MHz
PMOS Switch On Resistance	ISW=200mA		200		mΩ
NMOS Switch On Resistance	ISW=200mA		180		mΩ
High Side Current Limit		1.5			A
SW Leakage Current	VIN=5.5V, VSW=0 or 5.5V, EN= GND			5	µA
EN Rising Threshold	Rising,	1.2			V
EN Falling Threshold	Falling			0.4	V
EN Input Current	VEN=5V		1	2	µA
Thermal Shutdown			160		°C

1. Product parametric performance is indicated in the Electrical Characteristics for the listed test conditions, unless otherwise noted. Product performance may not be indicated by the Electrical Characteristics if operated under different conditions. 2. Guaranteed by design, no production test

## PIN DESCRIPTION

PIN #	NAME	DESCRIPTION
1	FB	Feedback Input. Connect an external resistor divider from the output to FB and GND to set the output to a voltage between 0.6V and $V_{IN}$
2	GND	Ground
3	IN	Supply Voltage. Bypass with a 10 $\mu$ F ceramic capacitor to GND
4	SW	Inductor Connection. Connect an inductor Between SW and the regulator output.
5	EN	Enable pin for the IC. Drive this pin high to enable the part, low to disable. Default low when floating
6	OUT	Output

## TYPICAL CHARACTERISTICS

(Typical values are at  $T_A = 25^\circ\text{C}$  unless otherwise specified.)

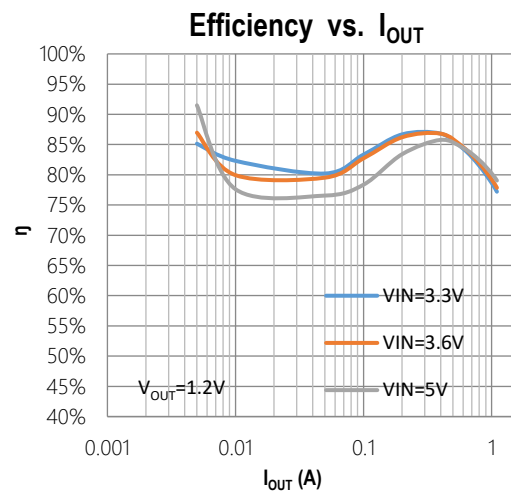
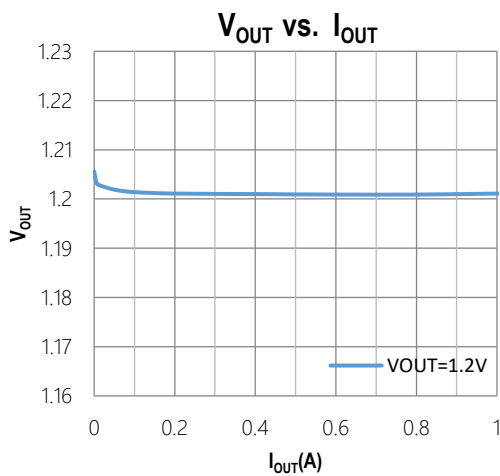
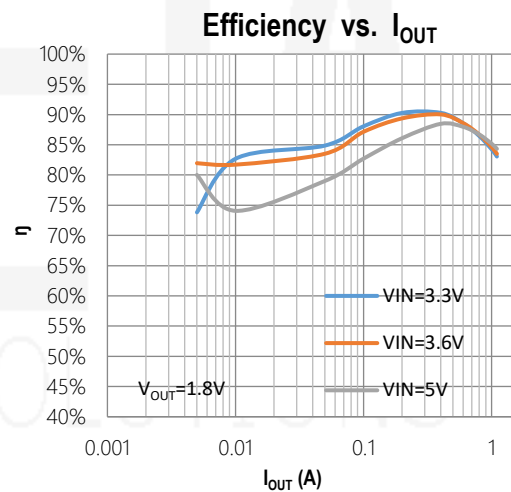
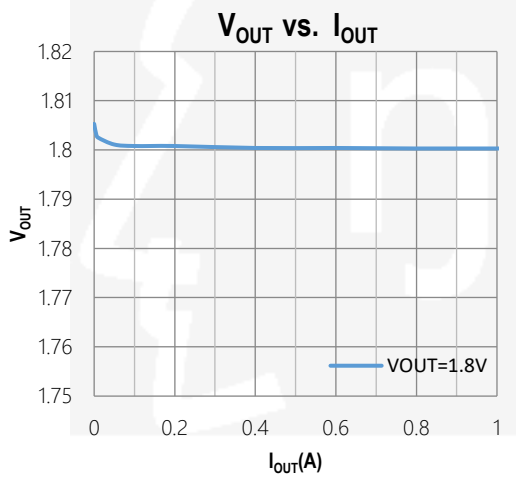

## TYPICAL CHARACTERISTICS (cont')

(Typical values are at  $T_A = 25^\circ\text{C}$  unless otherwise specified.)

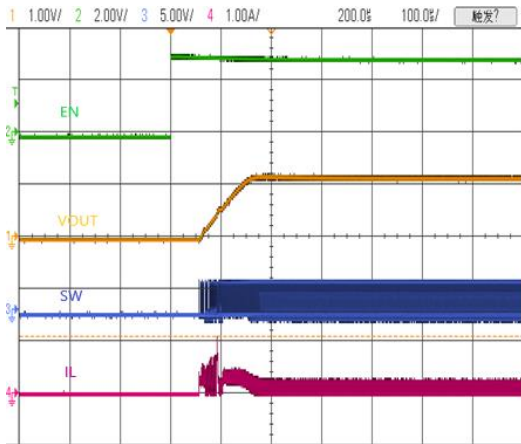

Power-on at  $V_{in}=3.3\text{V}$ , 0.1Amp loading

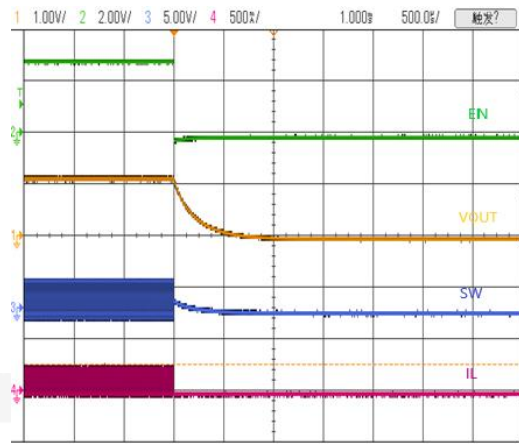

Power-off at  $V_{in}=3.3\text{V}$ , 0.1Amp loading

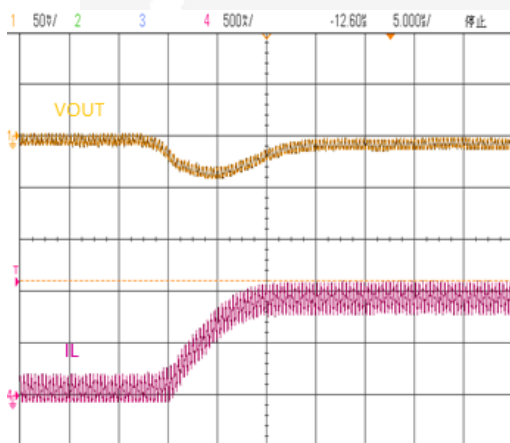

Transient ripple at 0.1A~1A

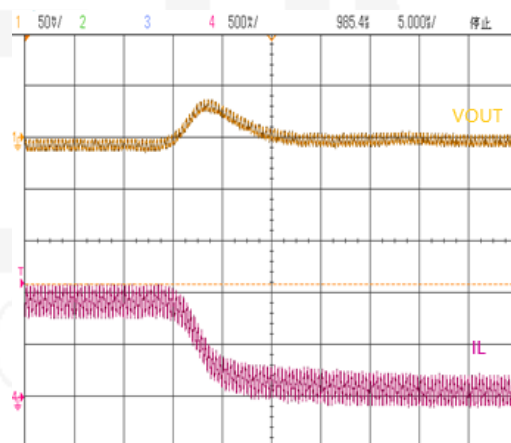

Transient ripple at 1A~0.1A

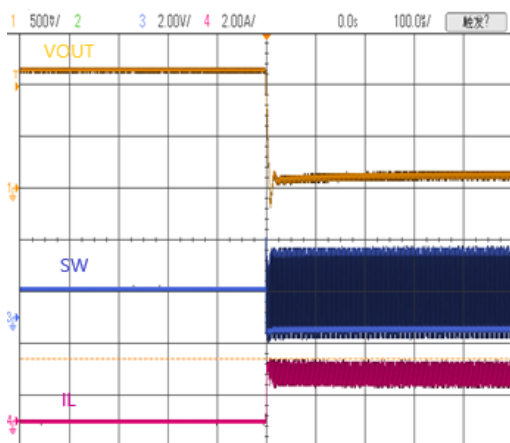

Short circuit protection

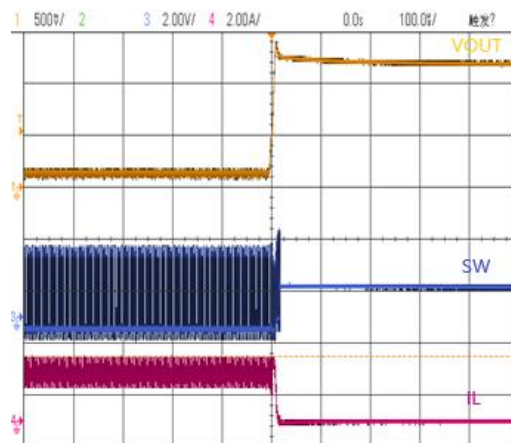

Short circuit recovery

## FUNCTIONAL BLOCK DIAGRAM

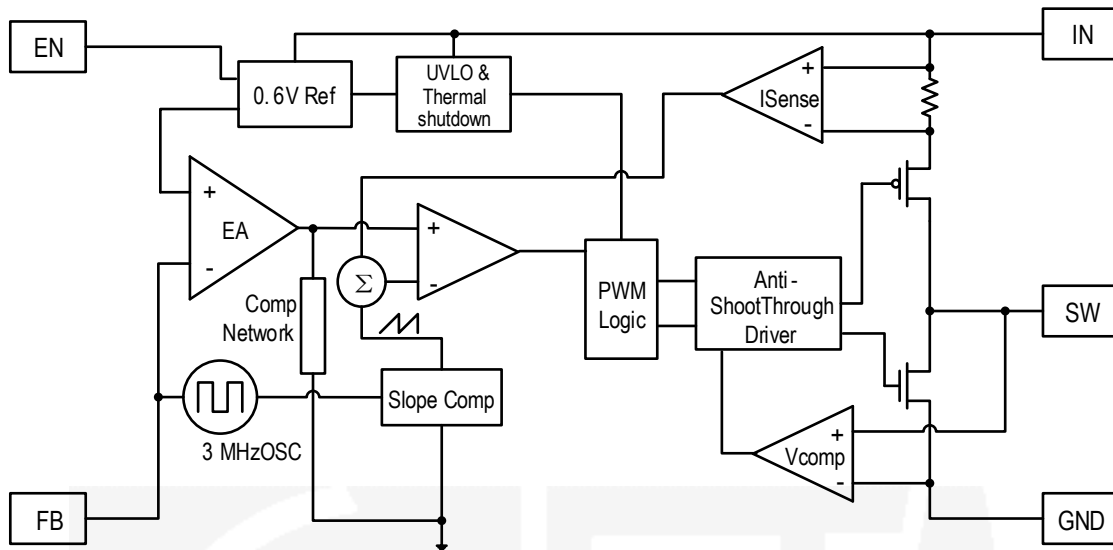

## FUNCTIONAL DESCRIPTION

The ETA3415 high efficiency switching regulator is a small, simple, DC-to-DC step-down converter capable of delivering up to 1A of output current. The device operates in pulse-width modulation (PWM) at 3MHz from a 2.6V to 7V input voltage and provides an output voltage from 0.6V to  $V_{IN}$ , making the ETA3415 ideal for on-board post-regulation applications. An internal synchronous rectifier improves efficiency and eliminates the typical Schottky free-wheeling diode. Using the on resistance of the internal high-side MOSFET to sense switching currents eliminates current-sense resistors, further improving efficiency and cost.

### Loop Operation

ETA3415 uses a PWM current-mode control scheme. An open-loop comparator compares the integrated voltage-feedback signal against the sum of the amplified current-sense signal and the slope compensation ramp. At each rising edge of the internal clock, the internal high-side MOSFET turns on until the PWM comparator terminates the on cycle. During this on-time, current ramps up through the inductor, sourcing current to the output and storing energy in the inductor. The current mode feedback system regulates the peak inductor current as a function of the output voltage error signal. During the off cycle, the internal high-side P-channel MOSFET turns off, and the internal low-side N-channel MOSFET turns on. The inductor releases the stored energy as its current ramps down while still providing current to the output.

### Current Sense

An internal current-sense amplifier senses the current through the high-side MOSFET during on time and produces a proportional current signal, which is used to sum with the slope compensation signal. The summed signal then is compared with the error amplifier output by the PWM comparator to terminate the on cycle.

### Current Limit

There is a cycle-by-cycle current limit on the high-side MOSFET. When the current flowing out of SW exceeds this limit, the high-side MOSFET turns off and the synchronous rectifier turns on. ETA3415 utilizes a frequency fold-back mode to prevent overheating during short-circuit output conditions. The device enters frequency fold-

back mode when the FB voltage drops below 200mV, limiting the current to  $I_{PEAK}$  and reducing power dissipation. Normal operation resumes upon removal of the short-circuit condition.

### *Soft-start*

ETA3415 has an internal soft-start circuitry to reduce supply inrush current during startup conditions. When the device exits under-voltage lockout (UVLO), shutdown mode, or restarts following a thermal-overload event, the soft-start circuitry slowly ramps up current available at SW.

### *UVLO and Thermal Shutdown*

If  $I_N$  drops below 2.05V, the UVLO circuit inhibits switching. Once  $I_N$  rises above 2.35V, the UVLO clears, and the soft-start sequence activates. Thermal-overload protection limits total power dissipation in the device. When the junction temperature exceeds  $T_J = +160^\circ\text{C}$ , a thermal sensor forces the device into shutdown, allowing the die to cool. The thermal sensor turns the device on again after the junction temperature cools by  $20^\circ\text{C}$ , resulting in a pulsed output during continuous overload conditions. Following a thermal-shutdown condition, the soft-start sequence begins.

## DESIGN PROCEDURE

### *Setting Output Voltages*

Output voltages are set by external resistors. The FB threshold is 0.6V.

$$R_{TOP} = R_{BOTTOM} \times [(V_{OUT} / 0.6) - 1]$$

### *Input Capacitor and Output Capacitor Selection*

The input capacitor in a DC-to-DC converter reduces current peaks drawn from the battery or other input power source and reduces switching noise in the controller. The impedance of the input capacitor at the switching frequency should be less than that of the input source so high-frequency switching currents do not pass through the input source. Input ripple with a ceramic capacitor is approximately as follows:

$$V_{RIPPLE} = I_{L(PEAK)} [1 / (2\pi \times f_{OSC} \times C_{IN})]$$

If the capacitor has significant ESR, the output ripple component due to capacitor ESR is as follows:

$$V_{RIPPLE(ESR)} = I_{L(PEAK)} \times ESR$$

The output capacitor keeps output ripple small and ensures control-loop stability. The output capacitor must also have low impedance at the switching frequency. Ceramic, polymer, and tantalum capacitors are suitable, with ceramic exhibiting the lowest ESR and high-frequency impedance.

### *Inductor Selection*

A reasonable inductor value ( $L_{IDEAL}$ ) can be derived from the following:

$$L_{IDEAL} = [2(V_{IN}) \times D(1 - D)] / I_{OUT} \times f_{OSC}$$

## PCB LAYOUT GUIDE

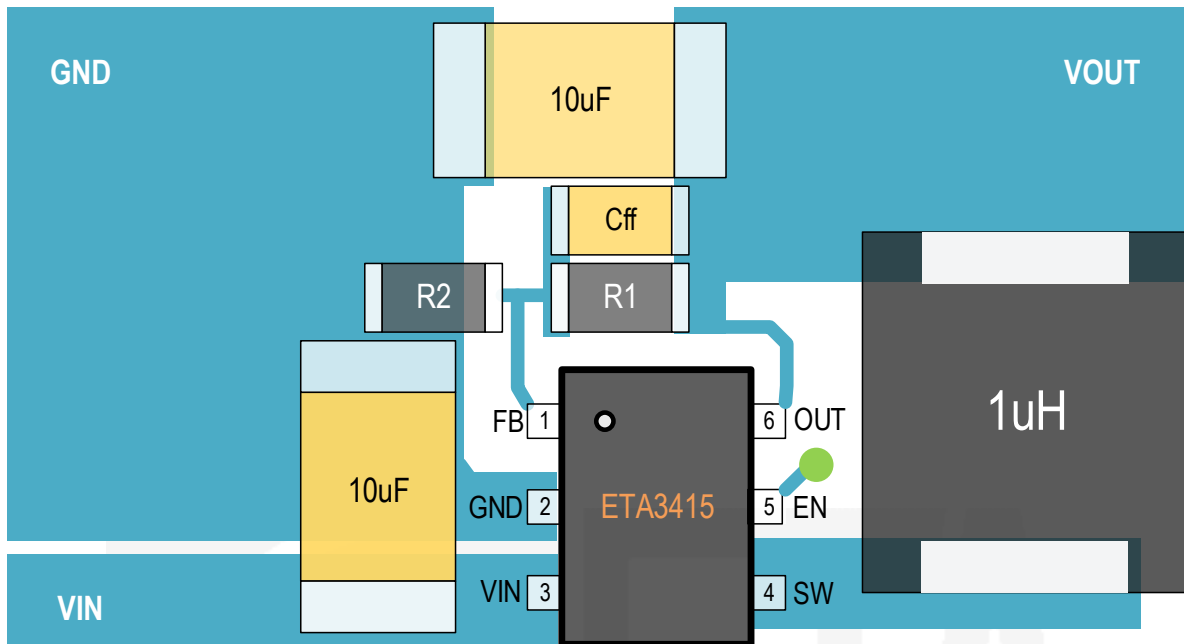

## PACKAGE OUTLINE

Package: SOT563

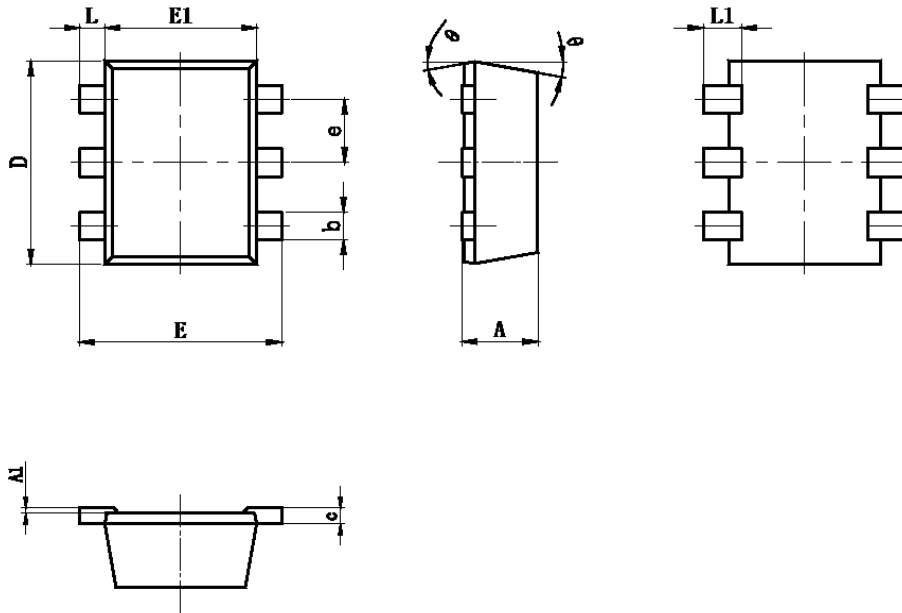

Symbol	Dimensions In Millimeters		Dimensions In Inches	
	Min.	Max.	Min.	Max.
A	0.525	0.600	0.021	0.024
A1	0.000	0.050	0.000	0.002
e	0.450	0.550	0.018	0.022
c	0.090	0.180	0.004	0.007
D	1.500	1.700	0.059	0.067
b	0.170	0.270	0.007	0.011
E1	1.100	1.300	0.043	0.051
E	1.500	1.700	0.059	0.067
L	0.100	0.300	0.004	0.012
L1	0.200	0.400	0.008	0.016
$\theta$	9° REF.		9° REF.	

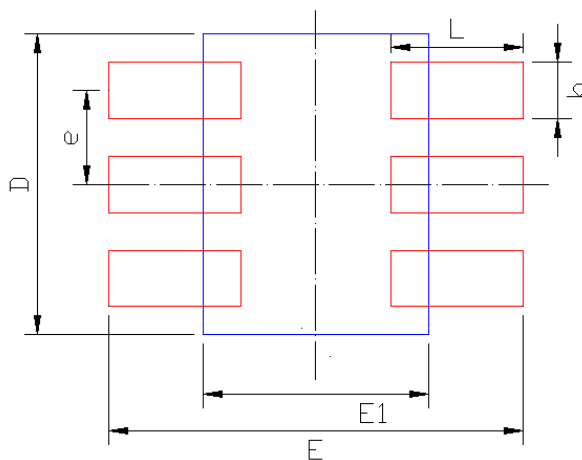

Dimensions	Value (in mm)
D	1.6
E	2.2
E1	1.2
e	0.5
b	0.3
L	0.7

RECOMMENDED LAND PATTERN



## PACKAGE OUTLINE

Package: DFN1.6x1.6-6

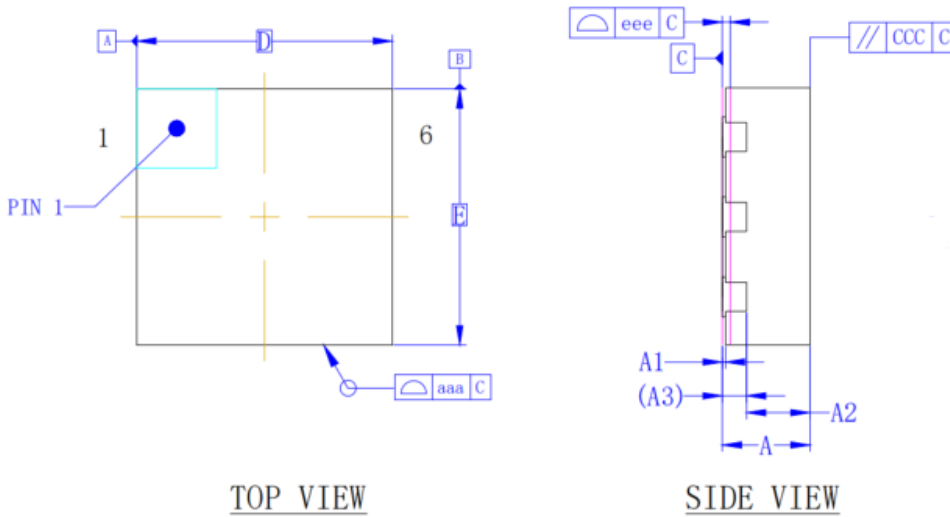

TOP VIEW

SIDE VIEW

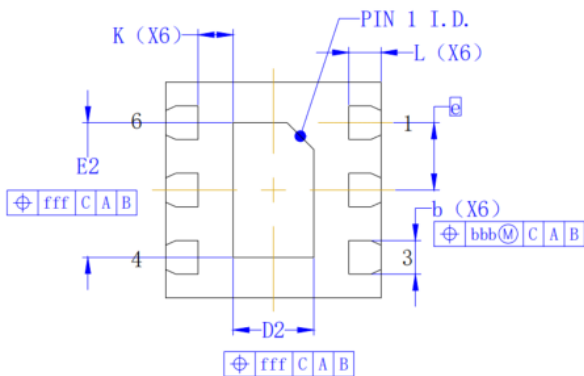

BOTTOM VIEW

Item	Symbol	Minimum	Normal	Maximum
Body Size	X	D		
	Y	E		
1.6 BSC				
Exposed Pad Size	X	D2		
	Y	E2		
0.50 0.60 0.70				
Total Thickness	A	0.50	0.55	0.60
Stand Off	A1	0	0.02	0.05
Molding Thickness	A2	0.40		
LF Thickness	A3	0.152 REF		
Lead Width	b	0.20	0.25	0.30
Lead Length	L	0.19	0.24	0.29
Lead Pitch	e	0.50 BSC		
Lead tip to Exposed Pad	K	0.26 REF		
Package Edge Tolerance	aaa	0.10		
Lead Offset	bbb	0.10		
Molding Flatness	ccc	0.10		
Coplanarity	eee	0.05		
Exposed Pad Offset	fff	0.10		

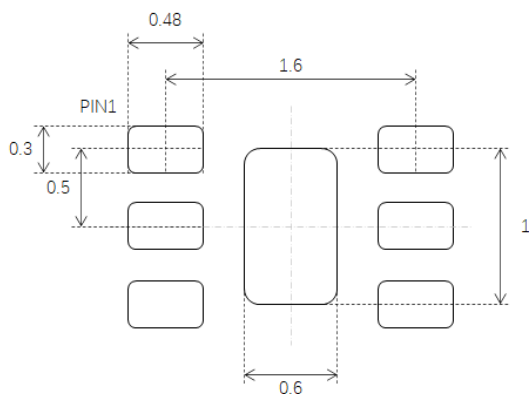

RECOMMENDED LAND PATTERN

## TAPE AND REEL INFORMATION

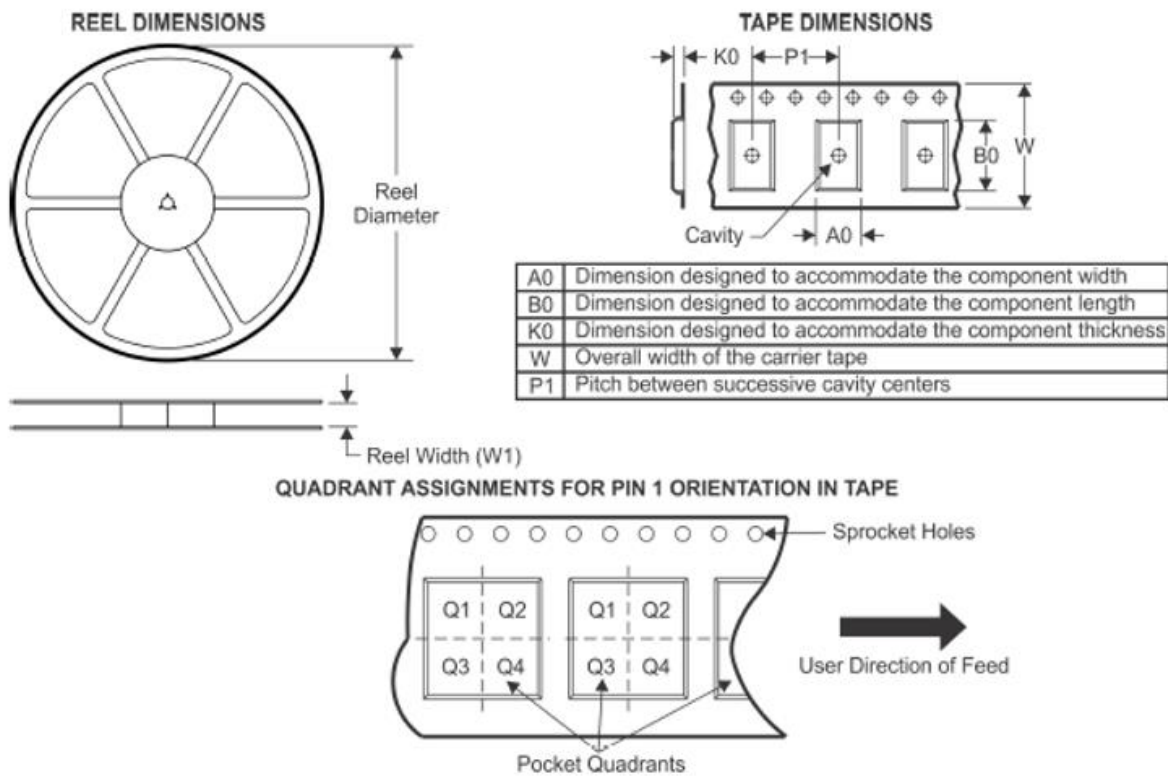

Device	Package Type	Pins	SPQ	Reel Diameter (mm)	Reel Width W1 (mm)	A0 (mm)	B0 (mm)	K0 (mm)	P1 (mm)	W (mm)	Pin1 Quadrant
ETA3415S6G	SOT563	6	3000	178	9.5	1.78	1.78	0.69	4	8	Q3
ETA3415DCG	DFN1.6x1.6-6	6	3000	180	9.5	1.73	1.73	0.72	4	8	Q1