

## Single Inductor, 2.5A Switch Mode Battery Charger with 1.5A USB OTG

### DESCRIPTION

ETA6095 is a switching Li-Ion battery charger capable of delivering up to 2.5A of charging current to the battery and also capable of delivering up to 1.5A in boost OTG operation, with high efficiency in both charging mode and OTG mode. For charging, it uses a proprietary control scheme that eliminates the current sense resistor for conventional constant current control, maximizing efficiency, reducing charging time and reducing costs. It can also output a 5V voltage in the reversed direction by boosting from the battery. It only needs a single inductor to provide power bi-directionally. ETA6095 is an ideal all-in-one solution for battery charging and discharge applications, such as power banks, smart phones, and tablets with only one USB port that can be used for both charging battery and USB OTG function.

ETA6095 is suitable for charging a 4.2V Li-ion battery. And ETA6095 is in DFN2x3-8 package.

### FEATURES

- ◆ Bi-Directional Power conversion with Single Inductor
- ◆ Switching Charger
- ◆ 5V Synchronous Boost
- ◆ Up to 95% Efficiency
- ◆ Up to 2.5A Max charging current and 1.5A discharging
- ◆ No-Battery detection
- ◆ No External Sense resistor

### APPLICATIONS

- ◆ Tablet, MID
- ◆ Smart Phone
- ◆ Power Bank

### TYPICAL APPLICATION

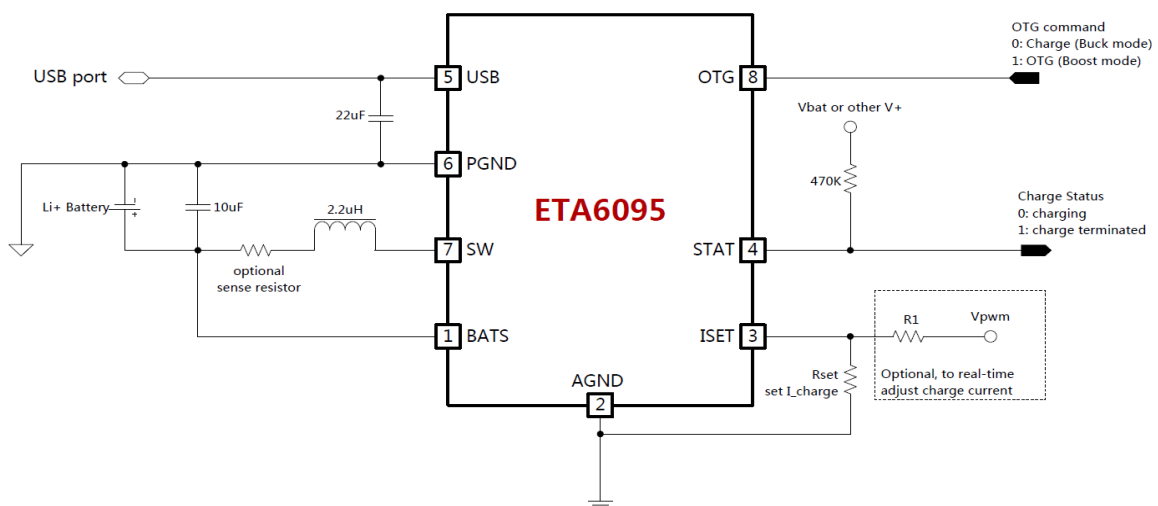

### ORDERING INFORMATION

| PART No.   | PACKAGE  | TOP MARK | Pcs/Reel |
|------------|----------|----------|----------|
| ETA6095D6I | DFN2x3-8 | JXYW     | 3000     |

## PIN CONFIGURATION

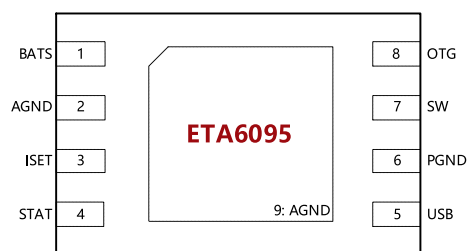

DFN2x3-8

## ABSOLUTE MAXIMUM RATINGS

(Note: Exceeding these limits may damage the device. Exposure to absolute maximum rating conditions for long periods may affect device reliability.)

|  |                                     |
|--|-------------------------------------|
| USB Voltage .....                              | -0.3V to 6V                         |
| All Other Pin Voltage .....                    | $V_{USB} - 0.3V$ to $V_{USB} + 0.3$ |
| SW, USB to ground current.....                 | Internally limited                  |
| Operating Temperature Range .....              | -40°C to 85°C                       |
| Storage Temperature Range .....                | -55°C to 150°C                      |
| Thermal Resistance $\theta_{JC}$ $\theta_{JA}$ |                                     |
| DFN2X3-8.....                                  | 20.....70 ..... °C/W                |
| Lead Temperature (Soldering, 10ssec) .....     | 260°C                               |
| ESD HBM (Human Body Mode) .....                | 2KV                                 |
| ESD MM (Machine Mode) .....                    | 200V                                |

## ELECTRICAL CHARACTERISTICS

( $V_{IN} = 5V$ , unless otherwise specified. Typical values are at  $T_A = 25°C$ .)

| PARAMETER                        | CONDITIONS                    | MIN  | TYP  | MAX  | UNITS   |
|----------------------------------|-------------------------------|------|------|------|---------|
| <b>BUCK MODE</b>                 |                               |      |      |      |         |
| USB Range                        |                               | 4.5  |      | 5.5  | V       |
| USB UVLO Voltage                 | Rising, Hys=500mV             |      | 4.5  |      | V       |
| USB OVP Voltage                  | Rising, Hys=320mV             | 5.89 | 6.08 | 6.27 | V       |
| USB Operating Current as BUCK    | Switcher Enable, Switching    |      | 5    |      | mA      |
|                                  | Switcher Enable, No Switching |      | 800  |      | $\mu$ A |
| <b>BATTERY CHARGER</b>           |                               |      |      |      |         |
| Battery CV Voltage               | $I_{BAT} = 0mA$ , default     | 4.17 | 4.21 | 4.25 | V       |
| Charger Restart Threshold        | From DONE to Fast Charge      |      | 160  |      | mV      |
| Battery Pre-Condition Voltage    | $V_{BAT}$ Falling Hys=250mV   |      | 2.9  |      | V       |
| Pre-Condition Charge Current     |                               |      | 200  |      | mA      |
| Fast Charge Current              | $R_{ISET} = 82K\Omega$        |      | 2    |      | A       |
|                                  | $R_{ISET} = 150K\Omega$       |      | 1.2  |      | A       |
| Charge Termination Current       |                               |      | 130  |      | mA      |
| Charge Termination Blanking time |                               |      | 16   |      | S       |
| <b>BOOST MODE</b>                |                               |      |      |      |         |
| BATT Ok Threshold                | Rising, HYS=0.6 V             |      | 3.1  |      | V       |
| Output Voltage Range             | $I_{out} = 100mA$             | 5.0  | 5.1  | 5.2  | V       |
| Quiescent Current At BATT        | $V_{bat} = 3.6V$              |      | 80   |      | $\mu$ A |
| Switching Frequency              | $V_{IN} < 4.3V$               | 0.9  | 1.2  | 1.5  | MHz     |
| Inductor Current Limit           |                               |      | 2.4  |      | A       |
| Maximum Duty Cycle               |                               |      | 90   |      | %       |

| PARAMETER                             | CONDITIONS             | MIN | TYP  | MAX | UNITS |
|---------------------------------------|------------------------|-----|------|-----|-------|
| Highside Pmos Rdson                   | I <sub>sw</sub> =500mA |     | 120  |     | mΩ    |
| Lowside Nmos Rdson                    | I <sub>sw</sub> =500mA |     | 100  |     | mΩ    |
| Short Circuit Hiccup Current          |                        |     | 1.8  |     | A     |
| Short Circuit Hiccup Timer            | On Time                |     | 62.5 |     | ms    |
|                                       | Off Time               |     | 2000 |     |       |
| <b>ISET</b>                           |                        |     |      |     |       |
| ISET Voltage                          |                        |     | 0.8  |     | V     |
| <b>LOGIC INPUT DTG</b>                |                        |     |      |     |       |
| Logic Input High                      |                        | 1.2 |      |     | V     |
| Logic Input Low                       |                        |     |      | 0.6 | V     |
| <b>THERMAL PROTECTION</b>             |                        |     |      |     |       |
| Charging Thermal Regulation threshold |                        |     | 85   |     | °C    |
| Thermal Shutdown                      | Rising, Hys=20°C       |     | 150  |     | °C    |

## PIN DESCRIPTION

| PIN # | NAME | DESCRIPTION  |
|-------|------|--|
| 1     | BATS | Battery Voltage sense pin. Connect to the battery positive terminal with a separate sensing wire to avoid voltage drop to achieve accurate battery CV charging       |
| 2     | AGND | Analog Ground. Connect to USB Cap separately   |
| 3     | ISET | Buck Charging current setting pin. Connect a resistor between this pin and analog ground to set the current level.   |
| 4     | STAT | Charge status indication pin. When in charging, STAT is pulled low. And STAT become high-impedance when charging is completed.                                       |
| 5     | USB  | USB 5V output during boost and Adaptive input current limited pin during charging. This is a power pin, by pass with 2x22uF ceramic caps closed to the pin and PGND. |
| 6     | PGND | Power Ground pin   |
| 7     | SW   | Switching Pin. Connect with an inductor between this pin and positive terminal of battery  |
| 8     | DTG  | Manual Force Boost operation pin. DTG=1, force Boost Operation. When DTG=0, Boost Operation is disabled  |

## TYPICAL CHARACTERISTICS

( $V_{in}=5V$ ,  $T_A=25^{\circ}C$ , unless otherwise specified)

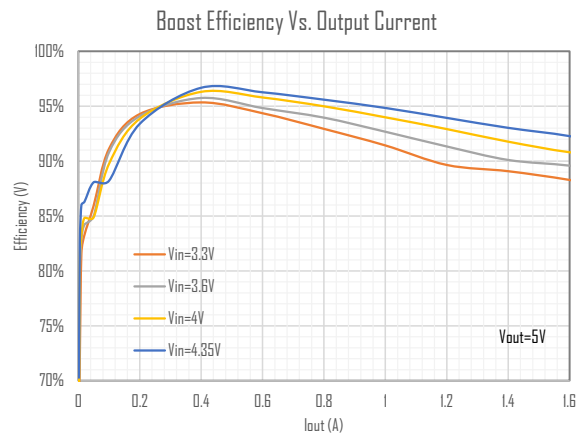
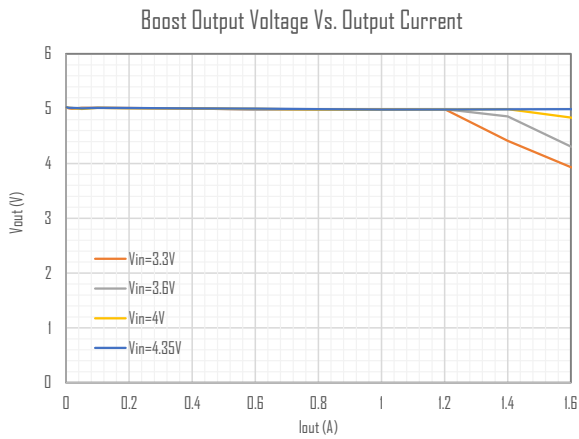
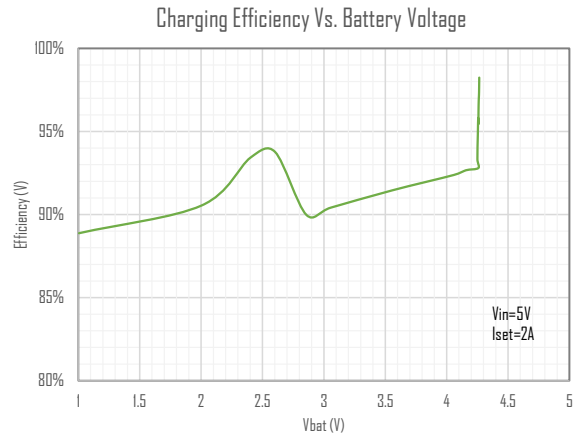
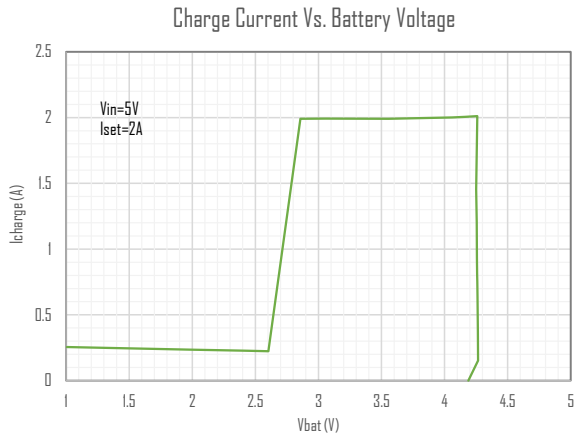

Complete charging cycle of a 5600mAH battery at 2.15A charge current

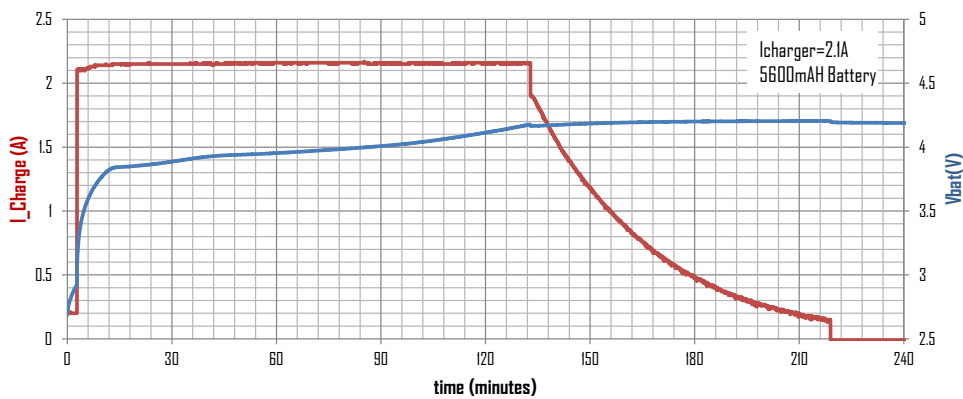

## FUNCTIONAL DESCRIPTION

ETA6095 is currently the most compact 2.5A switching charger together with 1.5A OTG current. It has only 8 pins, with an input OTG pin to set ETA6095 in charge mode (Buck conversion) when OTG pin is set "0" or OTG mode (Boost conversion) when OTG pin is set "1". Charge current can be set by an external resistor connecting to ISET pin, and charge status is output by STAT pin.

### Switching Battery Charger

ETA6095 is configured in charge mode (Buck conversion) when Vin is valid and OTG pin is set to "0". In this mode, a battery is charged with preconditioning, fast charge, top-off and end of charge (EOC).

#### CC/CV Regulation Loop

There are CC/CV regulation loops built in ETA6095, with regulates either current or voltage as necessary to ensure fast and safe charging of the battery. In a normal charge cycle, this loop regulates the current to the value set by the external resistor at the ISET pin. Charging continues at this current until the battery cell voltage reaches the termination voltage. At this point, the CV loop takes over, and charge current is allowed to decrease as necessary to maintain charging at the termination voltage.

#### Precondition Charge

A new charging cycle begins with the precondition state, and operation continues in this state until Vbat exceeds the precondition threshold voltage. When operating in precondition state, the cell is charged at 200mA. Once Vbat reaches the precondition threshold voltage, the state machine jumps to the fast charge state.

#### Fast Charge

If battery voltage is above preconditioning threshold, buck converter charges battery with constant current. In fast charge state, the ETA6095 charges at the current set by external resistor connected at ISET pin. For example, a 2A fast charge current can be achieved by setting the resistor to be 91K. During a normal charge cycle, fast charge continues in CC mode until Vbat reaches the charge termination voltage, at which point the ETA6095 enters into top off state.

#### Top off

With the battery voltage approaches the end of charge (EOC) voltage (4.2V, preset internally), charge current decreases as charging

continues. In the top off state, the cell is charged in constant voltage (CV) mode. During a normal charging cycle, charging proceeds until the charge current decreases below 130mA, the EOC threshold. And then, the state machine terminates the charge cycle and jumps to the EOC state.

#### End of charge

When charge current decreases to 130mA, the buck converter ceases and keep monitoring the battery voltage.

#### Recharge

When battery voltage drops by 160mV below the EOC voltage, the Buck converter is turned on again, and re-start the constant current charge cycle.

#### OTG mode – Synchronous Boost Converter

When OTG pin is set to "1", ETA6095 work as a synchronous boost converter, delivery 5V voltage to the USB pin with as much as 1.5A current. In this mode, the battery becomes the power input and USB as an output, current flows just the opposite way compared to the charge mode.

#### Sense resistor in serial with battery

One can connect a serial current sense resistor to battery to sense the charge and discharge current through the battery, as illustrated in the typical application circuit shown on page 1. The sense resistor is not a must for ETA6095 charge loop control or constant current control. In other words, ETA6095 does not rely on this resistor to control the charge current. So please use it only when charge and discharge current need to be measured for gas gauge purpose.

## ADJUSTING CHARGE CURRENT by PWM VOLTAGE

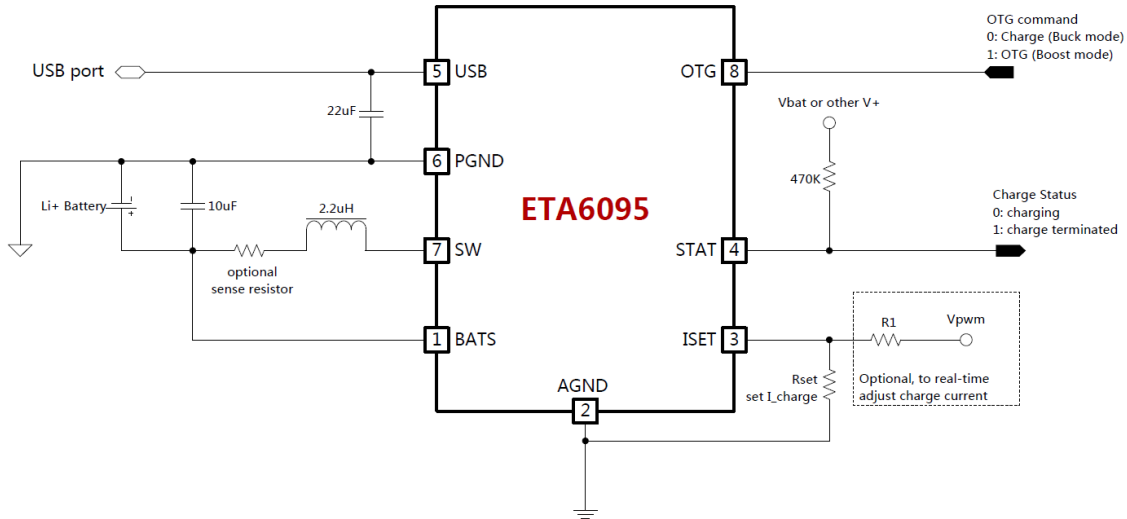

As given by above application circuit, one can real-time adjust the charge current by a PWM signal with different duty-cycle. The  $V_{pwm}$  is the RC filtered voltage of the PWM signal, and it will change linearly with the duty-cycle of the PWM signal. Followings are 2 examples of charge current's relationship to  $V_{pwm}$ . Please contact ETA engineers if one wants to have specific real-time charge current setting, the choosing of  $R1$  and  $Rset$  value will be provided quickly.

Charge Current Vs.  $V_{pwm}$  at  $R1=200K$ ,  $Rset=160K$

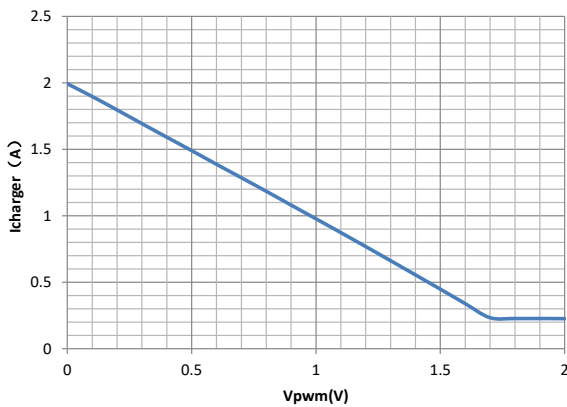

Charge Current Vs.  $V_{pwm}$  at  $R1=220K$ ,  $Rset=130K$

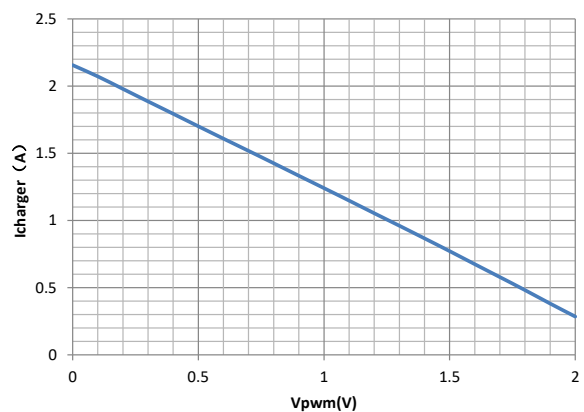

## OVER VOLTAGE PROTECTION

As such ETA6095 is always connected directly to the USB input interface, which occasionally suffers from high voltage spike caused by adapter's plugging in. A simple and cost-effective over-voltage circuit is proposed, please refer to the circuit on the next page. The NPN (8050) will turn on when input voltage is larger than 6.6V, and will switch off the NMOS (8205) very quickly, so that a very fast and effective over-voltage-protection (OVP) of the whole system board is achieved. As such protection is inserted at the Ground side, so please make sure there is **no other bypassing ground path** connected to USB V- without going through this OVP circuit.

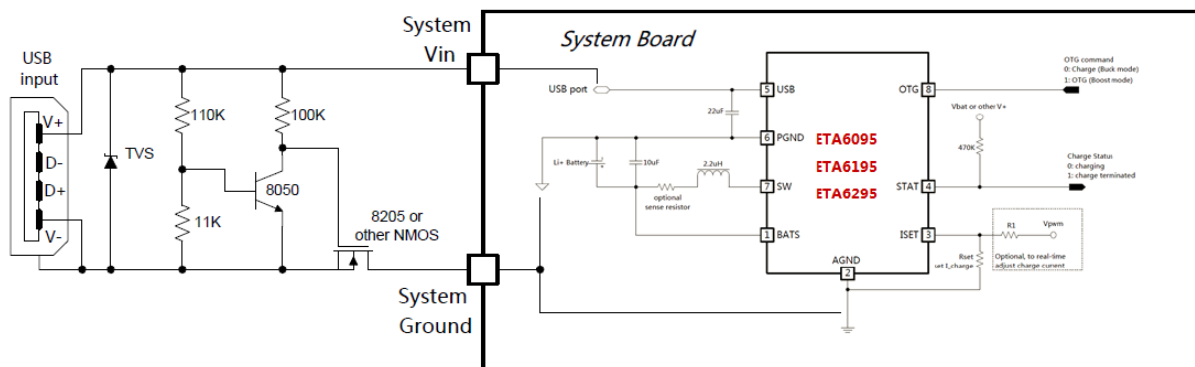

## PCB GUIDES

A Simple ETA6095 PCB illustration is shown below, Please place the output capacitor Cout1, Cout2 and Cout3 as close as possible to the ETA6095 pins. A good practice is just follow what is drawn below, with Cout1 and Cout2 connecting the ETA6095 USB and PGND pins and Cout3 connecting USB and AGND thru bottom head dissipation pad.

Please always place these 3 output capacitors as the first step, and all other peripheral devices are less crucial than these output capacitors.

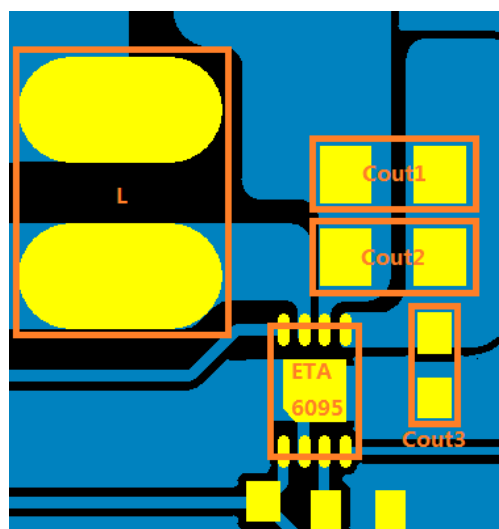

PACKAGE OUTLINE

DFN2x3-8

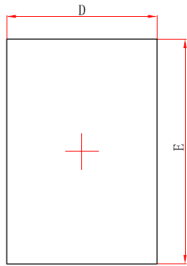

Top View

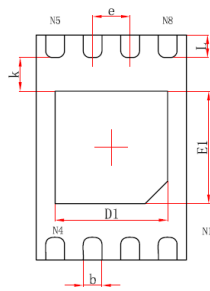

Bottom View

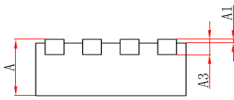

Side View

| Symbol | Dimensions In Millimeters |       | Dimensions In Inches |       |
|--------|---------------------------|-------|----------------------|-------|
|        | Min.                      | Max.  | Min.                 | Max.  |
| A      | 0.700                     | 0.800 | 0.028                | 0.031 |
| A1     | 0.000                     | 0.050 | 0.000                | 0.002 |
| A3     | 0.203REF.                 |       | 0.008REF.            |       |
| D      | 1.924                     | 2.076 | 0.076                | 0.082 |
| E      | 2.924                     | 3.076 | 0.115                | 0.121 |
| D1     | 1.400                     | 1.600 | 0.055                | 0.063 |
| E1     | 1.400                     | 1.600 | 0.055                | 0.063 |
| k      | 0.200MIN.                 |       | 0.008MIN.            |       |
| b      | 0.200                     | 0.300 | 0.008                | 0.012 |
| e      | 0.500TYP.                 |       | 0.020TYP.            |       |
| L      | 0.224                     | 0.376 | 0.009                | 0.015 |