

Power Management Unit for Power Banks

DESCRIPTION

The ETA9635 is a fully integrated power management unit specifically designed for Power Bank, Mobile Charger, Backup Battery Charger applications. It consists of a high efficiency synchronous step-up boost converter and a linear battery charger. The boost can provide up to 1A output current at 5V of from a Li-Ion battery input voltage, while the charger can charge up to 1A of current from an AC adapter input. The boost incorporates circuits that disconnect the input from output, during shutdown, short-circuit, output current overloading, or other events when output is higher than the input. This not only eliminates the need for an external MOSFET and its control circuitry to disconnect the input from output, also provides robust output overload protection. Using a patent pending technique to drive the charger LED indicator, it eliminates the need for a micro-controller normally needed in mobile chargers. While saving the cost of a micro-controller, since the whole units only consumes less than 50uA of quiescent current during no load, when considering standby time for one charge, it is a much superior solution comparing to the traditional solution that needs a micro-controller which

normally consumes up to 1mA current.
ETA9635 is available in SOP8 package.

FEATURES

- **Zin 1: A Synchronous boost plus A Charger**
- **Short-circuit Protection**
- **5W Output Power from the Boost**
- **Boost Output to Input Reversed Current Protection**
- **Up to 1A Charging**
- **Up to 96% Efficiency during Boosting**
- **50µA No load I_Q**
- **Programmable Charging Current**

APPLICATIONS

- Power Banks
- Mobile back-up Battery Chargers

ORDERING INFORMATION

PART #	PACKAGE PIN	TOP MARK
ETA9635S8A	SOP-8	ETA9635-Product Number YWWPL- Date Code

TYPICAL APPLICATION

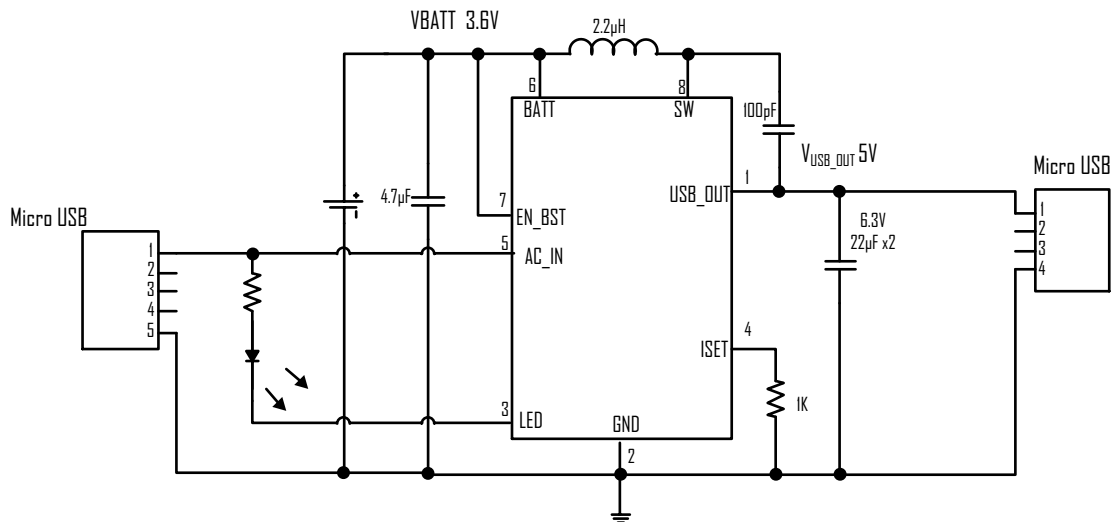

PIN CONFIGURATION

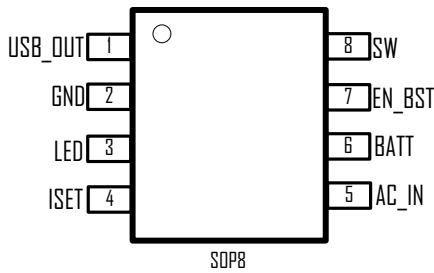

ABSOLUTE MAXIMUM RATINGS

(Note: Exceeding these limits may damage the device. Exposure to absolute maximum rating conditions for long periods may affect device reliability.)

SW Voltage.....	-0.3V to 5.5V
All Other PIN Voltages.....	-0.3V to 5V
SW to ground current	Internally limited
Operating Temperature Range	-40°C to 85°C
Storage Temperature Range	-55°C to 150°C
Thermal Resistance	θ_{JA} θ_{JC}
SOP8.....	90.....45°C/W

ELECTRICAL CHARACTERISTICS

($V_{IN} = 1.8V$, $V_{OUT} = 3.3V$, unless otherwise specified. Typical values are at $T_A = 25^\circ C$.)

PARAMETER	CONDITIONS	MIN	TYP	MAX	UNITS
SYNCHRONOUS BOOST					
Minimum Input Voltage			0.6		V
Startup Voltage	$I_{OUT}=0A$		0.85	1.1	V
FB Feedback Voltage	$V_{OUT} = 2.1$ to 5V	0.582	0.6	0.618	V
FB Input Current				50	nA
Output Voltage Range	External divider	2.1		5	V
Quiescent Current at IN	$V_{FB}=0.7V$		40		μA
Shutdown Supply Current at IN	$V_{EN}=GND$		0.5	5	μA
Switching Frequency	$V_{IN}<4.3V$	1.2	2	2.4	MHz
Maximum Duty Cycle		90			%
NMOS Switch On Resistance	$I_{SW} = 100mA$		0.15	0.35	Ω
PMOS Switch On Resistance	$I_{SW} = 100mA$		0.15	0.35	Ω
NMOS Switch Current Limit		1.2	1.5		A
Start-up Current Limit			0.5		A
Output to Input Reverse Leakage Current	$V_{EN}=GND$, Measure at IN pin		0.1	5	μA
SW Leakage Current	$V_{OUT}=5V, V_{SW}=0$ or 5V, $V_{EN}=GND$			10	μA
LINEAR CHARGER					
EN Input Current			0.1	1	μA
EN Input Low Voltage				0.3	V
EN Input High Voltage		0.6			V
Thermal Shutdown	Rising, Hysteresis= $10^\circ C$		165		$^\circ C$

PIN DESCRIPTION

PIN #	NAME	DESCRIPTION
1	EN	Enable pin for the IC. Drive this pin high to enable the part, low to disable.
2	FB	Feedback Input. Connect an external resistor divider from the output to FB and GND to set V_{OUT}
3	OUT	Output pin. Bypass with a 22 μF or larger ceramic capacitor closely between this pin and GND

PIN #	NAME	DESCRIPTION
4	GND	Ground Pin
5	SW	Inductor Connection. Connect an inductor Between SW and the regulator output.
6	IN	Input Supply Voltage. Bypass with a 4.7 μ F ceramic capacitor to GND

TYPICAL CHARACTERISTICS (BOOST)

(Typical values are at TA = 25 $^{\circ}$ C unless otherwise specified.)

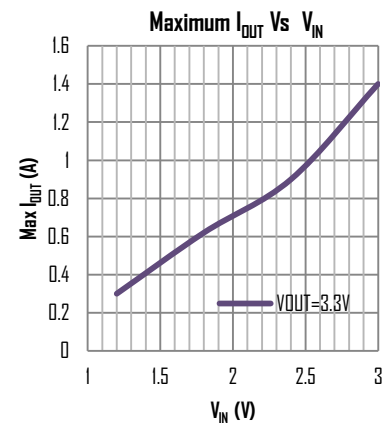
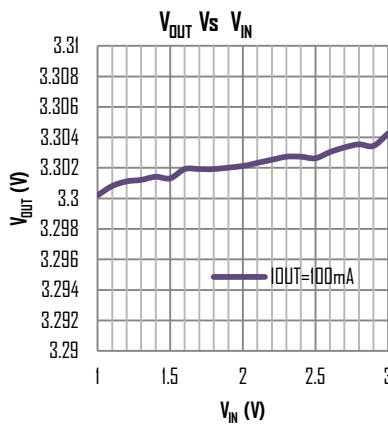
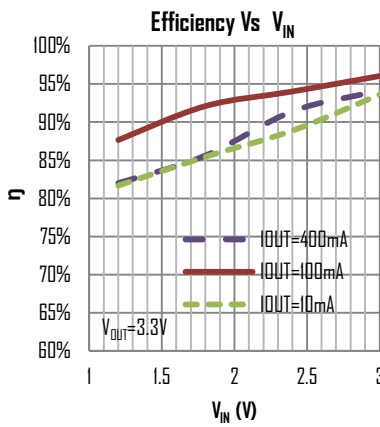
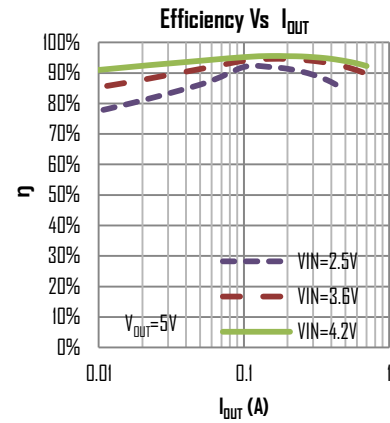
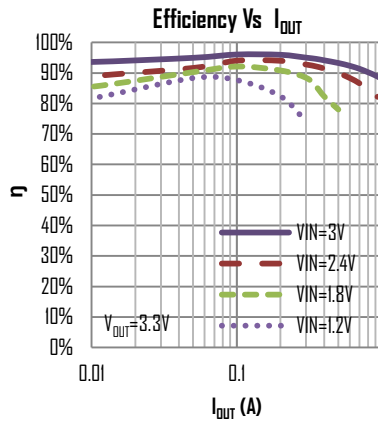
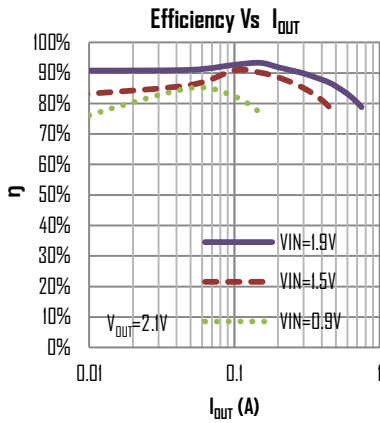

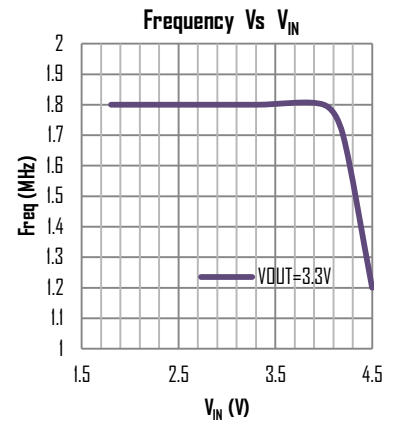
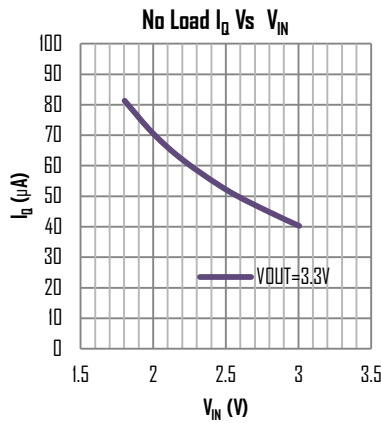
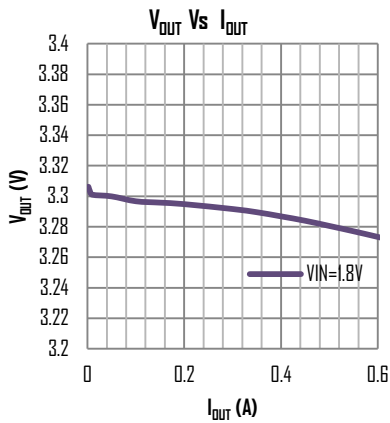

TYPICAL CHARACTERISTICS (BOOST)

(Typical values are at TA = 25°C unless otherwise specified.)

Heavy load Switching Waveform
VIN=1.8V, VOUT=3.3V, IOUT= 500mA

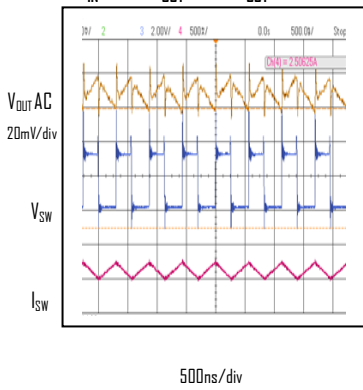

Light load Switching Waveform
VIN=1.8V, VOUT=3.3V, IOUT= 10mA

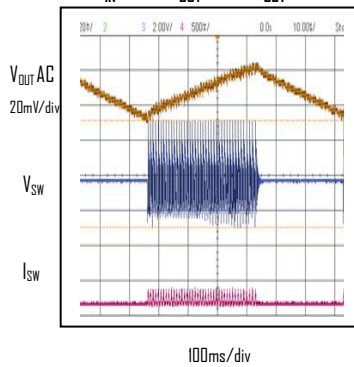

Short-Circuit Response
VIN=3V, VOUT=3.3V

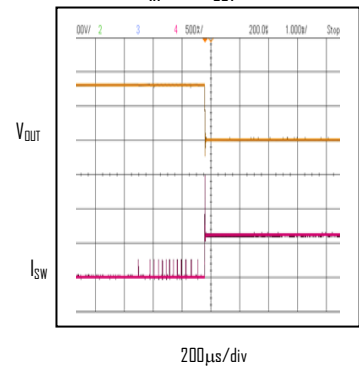

Short-Circuit Recovery
VIN=3V, VOUT=3.3V

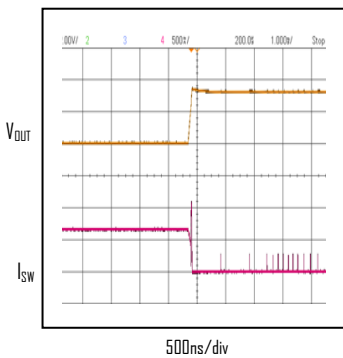

Start-Up Waveform
VIN=3.0V, VOUT=3.3V, IOUT= 500mA

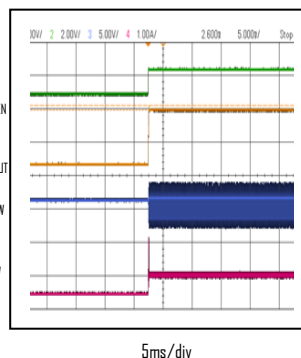

Shut Down Waveform
VIN=3.0V, VOUT=3.3V, IOUT= 500mA

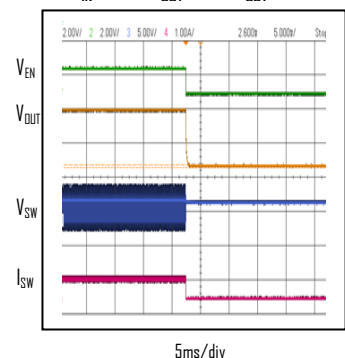

Load Transient Response
VIN=3V, VOUT=3.3V IOUT=0.1A to 0.5A

Load Transient Response
VIN=3V, VOUT=3.3V IOUT=0.1A to 1A

Line Transient Response
VOUT=3.3V, IOUT= 100mA VIN=1.2V to 3V

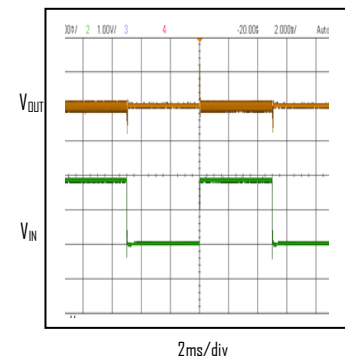
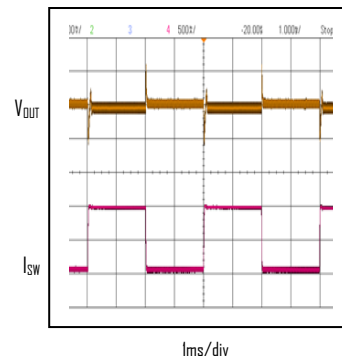
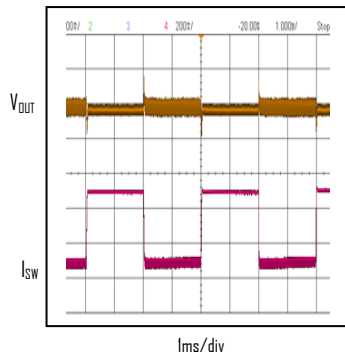

FUNCTIONAL DESCRIPTIONS

Loop Operation

The ETA9635 is a wide input range, high-efficiency, DC-to-DC step-up switching regulator, capable of delivering up to 3W of output power, integrated with a 150mΩ high side MOSFET and 150 mΩ synchronous rectifier. It uses a PWM current-mode control scheme. An error amplifier integrates error between the FB signal and the internal reference voltage. The output of the integrator is then compared to the sum of a current-sense signal and the slope compensation ramp. This operation generates a PWM signal that modulates the duty cycle of the power MOSFETs to achieve regulation for output voltage.

Light Load Operation

Traditionally, a fixed constant frequency PWM DC-DC regulator always switches even when the output load is small. When energy is shuffling back and forth through the power MOSFETs, power is lost due to the finite RDS(ON)s of the MOSFETs and parasitic capacitances. At light load, this loss is prominent and efficiency is therefore very low. ETA9635 employs a proprietary control scheme that improves efficiency in this situation by enabling the device into a power save mode during light load, thereby extending the range of high efficiency operation.

Short-Circuit Protection

Unlike most step-up converters, the ETA9635 allows for short circuits on the output. In the event of a short circuit, the device first turns off the NMOS when the sensed current reaches the current limit. After V_{OUT} drops below V_{IN} the device then enters a linear charge period with the current limited same as with the start-up period. In addition, the thermal shutdown circuits disable switching if the die temperature rises above 165°C.

Down Mode ($V_{IN} > V_{OUT}$) Operation

The ETA9635 will continue to supply the output voltage even when the input voltage exceeds the output voltage. Since the PMOS no longer acts as a low-impedance switch in this mode, power dissipation increases within the IC to cause a sharp drop in efficiency. Limit the maximum output current to maintain an acceptable junction temperature.

COMPLETE POWER BANK SOLUTION

PACKAGE OUTLINE

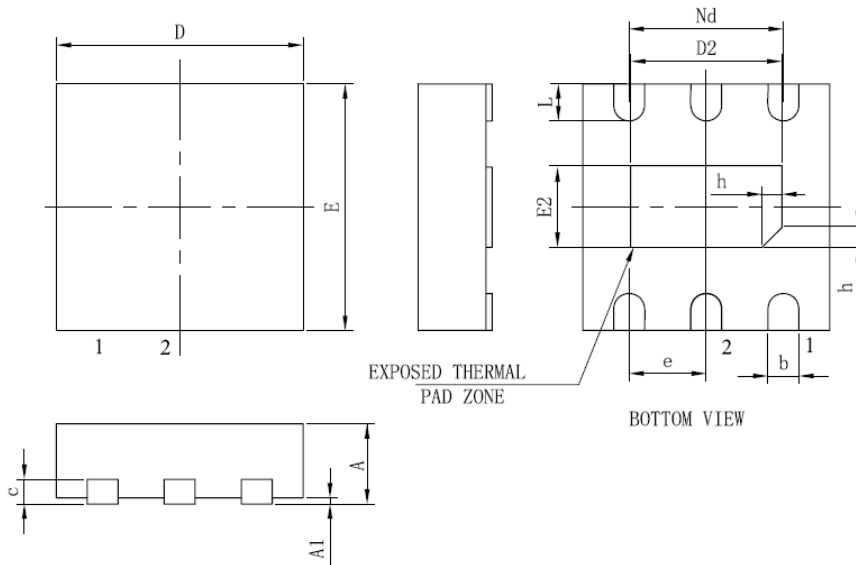

SYMBOL	MILLIMETER		
	MIN	NOM	MAX
A	0.70	0.75	0.80
A1	—	0.02	0.05
b	0.25	0.30	0.35
c	0.18	0.20	0.25
D	1.95	2.00	2.05
D2	1.00	—	1.45
e	0.65BSC		
Nd	1.30BSC		
E	1.95	2.00	2.05
E2	0.50	—	0.85
L	0.25	0.30	0.40
h	0.10	0.15	0.20