

ETD29 SERIES POWER TRANSFORMER MODULES

PRODUCT OVERVIEW:THT POWER TRANSFORMERS

Characteristics

High insulation type High efficiency
 IEC60950 Compatible
 Operating temperature range:-40°C to +85°C

Applications

Lighting
 metering
 industrial Controls
 White Goods
 Telecom
 Stand-by Power



Bobbin Winding Area

Width(mm)	Build(mm)	Perimeter(mm)
19.5	4.9	37.1

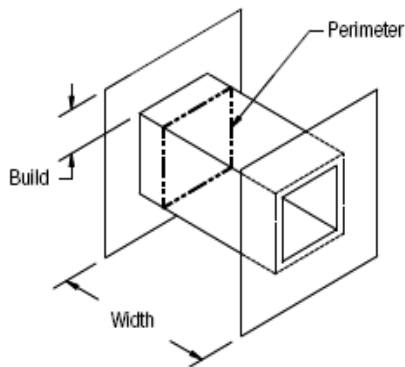

CORE DATA

Ae (mm ²)	Ve (mm ³)	Le (mm)
76.18	5357.74	70.33

POWER LEVEL (W)

Flyback	Forward	Push-pull
71	106	212

Test frequency:100KHz

THT Horizontal

Dimensions & Footprint

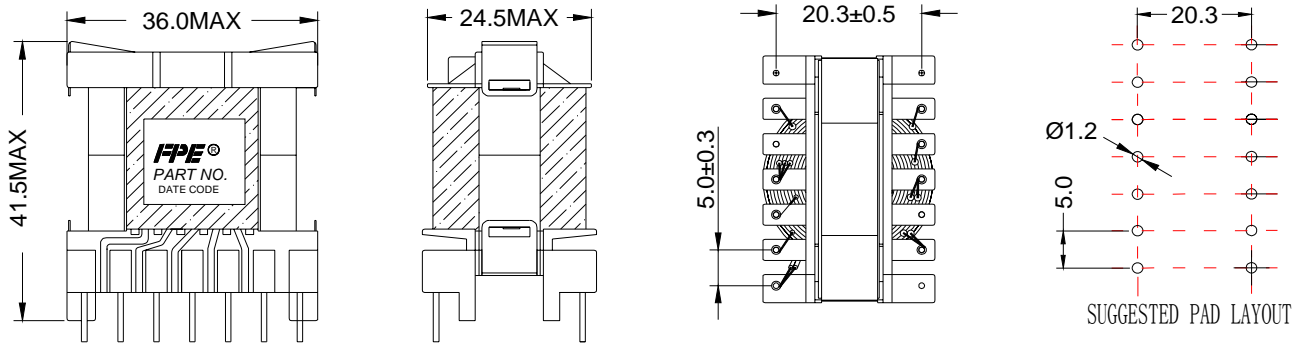

THT Vertical

Dimensions & Footprint

