

ETD34 SERIES POWER TRANSFORMER MODULES

PRODUCT OVERVIEW:THT POWER TRANSFORMERS

Characteristics

High insulation type High efficiency
 IEC60950 Compatible
 Operating temperature range:-40°C to +85°C

Applications

Lighting
 metering
 industrial Controls
 White Goods
 Telecom
 Stand-by Power



Bobbin Winding Area

Width (mm)	Build (mm)	Perimeter (mm)
21.5	6.8	35.8

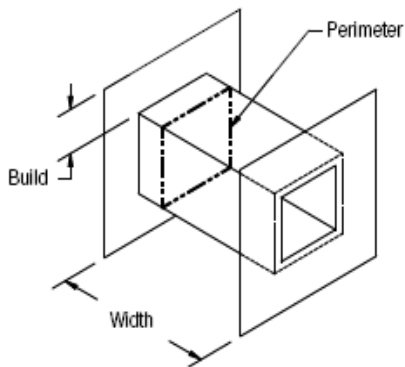

CORE DATA

Ae (mm ²)	Ve (mm ³)	Le (mm)
93.38	7374.69	78.98

POWER LEVEL (W)

Flyback	Forward	Push-pull
116	174	348

Test frequency:100KHz

THT Horizontal

Dimensions & Footprint

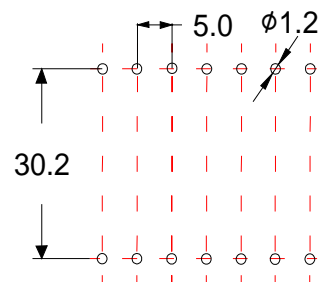
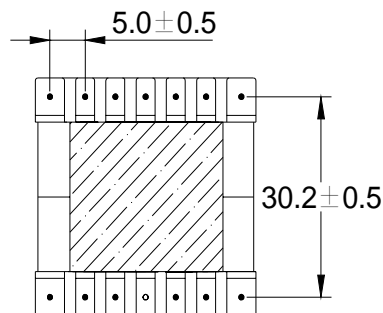
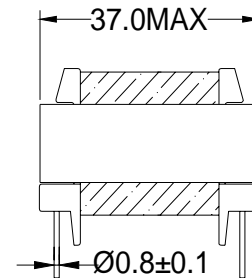
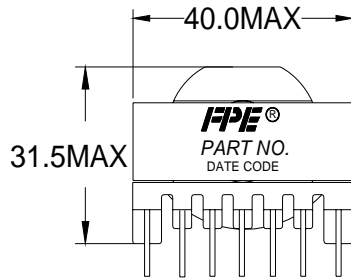

SUGGESTED PAD LAYOUT