

## ETD39 SERIES POWER TRANSFORMER MODULES

### PRODUCT OVERVIEW: THT POWER TRANSFORMERS

#### Characteristics

High insulation type High efficiency  
IEC60950 Compatible  
Operating temperature range: -40°C to +85°C

#### Applications

Lighting  
metering  
industrial Controls  
White Goods  
Telecom  
Stand-by Power



#### Bobbin Winding Area

Width (mm)	Build (mm)	Perimeter (mm)
25.9	6.6	47.1

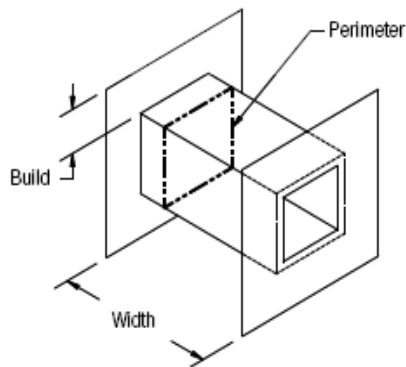

#### CORE DATA

Ae (mm <sup>2</sup> )	Ve (mm <sup>3</sup> )	Le (mm)
123.92	12078.48	97.47

#### POWER LEVEL (W)

Flyback	Forward	Push-pull
203	305	609

Test frequency: 100KHz

#### THT Horizontal

Dimensions & Footprint

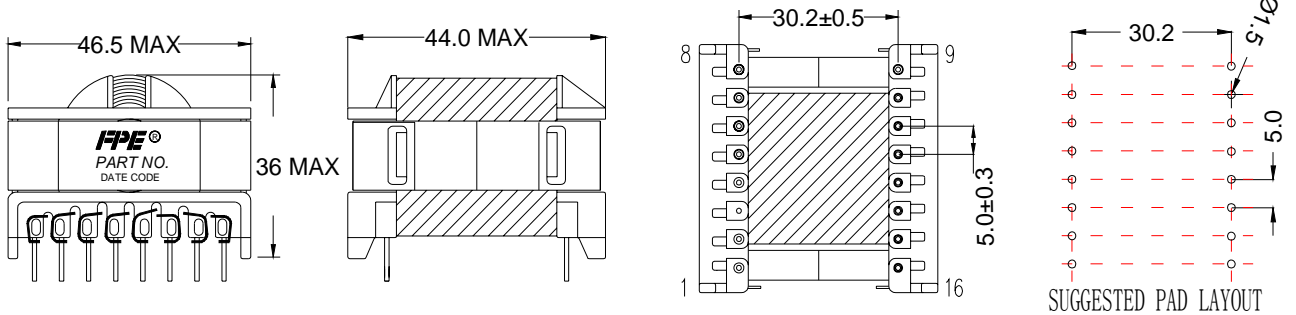

#### THT Vertical

Dimensions & Footprint

