

EXAMINED BY :	EMERGING DISPLAY TECHNOLOGIES CORPORATION	FILE NO . CAS-0007688
Lucica Lu		ISSUE : JAN.06, 2015
APPROVED BY:		TOTAL PAGE : 28
Vincent Wh		VERSION : 2

CUSTOMER ACCEPTANCE SPECIFICATIONS

MODEL NO. :  
ETM057010BDHU  
 (RoHS)  
 FOR MESSRS :  
 \_\_\_\_\_

CUSTOMER'S APPROVAL

DATE :  
 \_\_\_\_\_

BY :  
 \_\_\_\_\_

EMERGING DISPLAY  
TECHNOLOGIES CORPORATION

MODEL NO.	VERSION	PAGE
ETM057010BDHU	2	0-1

RECORDS OF REVISION	DOC . FIRST ISSUE	FEB.26, 2013
---------------------	-------------------	--------------

DATE	REVISED PAGE NO.	SUMMARY								
JAN.06 ,2015	14	10.2 CN2 SIGNAL INTERFACES								
		<table border="1"> <tr> <td>PIN NO.</td> <td>FUNCTION</td> <td>PIN NO.</td> <td>FUNCTION</td> </tr> <tr> <td>8</td> <td>EXTERNAL INTERRUPT FROM THE HOST</td> <td>8</td> <td>FOR EDT INTERNAL USE (CUSTOMER DON'T USE)</td> </tr> </table>	PIN NO.	FUNCTION	PIN NO.	FUNCTION	8	EXTERNAL INTERRUPT FROM THE HOST	8	FOR EDT INTERNAL USE (CUSTOMER DON'T USE)
PIN NO.	FUNCTION	PIN NO.	FUNCTION							
8	EXTERNAL INTERRUPT FROM THE HOST	8	FOR EDT INTERNAL USE (CUSTOMER DON'T USE)							
<p>CONFIDENTIAL</p> <p>Authorized for</p> <p>Emerging Display Technologies Corporation Only.</p> <p>Do not distribute without authorization.</p>										

TABLE OF CONTENTS

NO.	ITEM	PAGE
1.	GENERAL SPECIFICATIONS -----	1
2.	MECHANICAL SPECIFICATIONS -----	1, 2
3.	ABSOLUTE MAXIMUM RATINGS -----	3
4.	ELECTRICAL CHARACTERISTICS -----	4
5.	TIMING CHARACTERISTICS -----	5 ~ 7
6.	OPTICAL CHARACTERISTICS -----	8, 9
7.	OUTLINE DIMENSIONS -----	10
8.	BLOCK DIAGRAM -----	11
9.	DETAIL DRAWING OF DOT MATRIX -----	12
10.	INTERFACE SIGNALS -----	13, 14
11.	POWER SUPPLY -----	15
12.	CAPACITIVE TOUCH PANEL SPECIFICATION -----	16 ~ 18
13.	INSPECTION CRITERION -----	19 ~ 28

CONFIDENTIAL  
Authorized for  
Emerging Display Technologies Corporation Only.  
Do not distribute without authorization.

## 1. GENERAL SPECIFICATIONS

### 1.1 DATA SHEETS FOR LCD PANEL CONTROLLER/DRIVER

PLEASE REFER TO :

HIMAX HX8250

HIMAX HX8678

### 1.2 DATA SHEETS FOR CAPACITIVE TOUCH PANEL

CONTROLLER/DRIVER PLEASE REFER TO :

FOCALTECH FT5406EE8

### 1.3 MATERIAL SAFETY DESCRIPTION

ASSEMBLIES SHALL COMPLY WITH EUROPEAN ROHS REQUIREMENTS, INCLUDING PROHIBITED MATERIALS/COMPONENTS CONTAINING LEAD, MERCURY, CADMIUM, HEXAVALENT CHROMIUM, POLYBROMINATED BIPHENYLS (PBB) AND POLYBROMINATED DIPHENYL ETHERS (PBDE)

## 2. MECHANICAL SPECIFICATIONS

### 2.1 TFT LCD MODULE MECHANICAL SPECIFICATIONS

( 1 ) DIAGONALS -----	5.7 inch
( 2 ) NUMBER OF DOTS -----	640W * (RGB) * 480H DOTS
( 3 ) MODULE SIZE -----	147.6W * 100.0H * 11.7D (MAX) mm (WITHOUT FPC)
( 4 ) EFFECTIVE AREA -----	117.2W * 88.4H mm
( 5 ) ACTIVE AREA -----	115.2W * 86.4H mm
( 6 ) DOT SIZE -----	0.06W * 0.18H mm
( 7 ) PIXEL SIZE -----	0.18W * 0.18H mm
( 8 ) LCD TYPE -----	TFT , TRANSMISSIVE
( 9 ) COLOR -----	16.7M
( 10 ) VIEWING DIRECTION -----	12 O'CLOCK
( 11 ) BACK LIGHT -----	LED , COLOR : WHITE
( 12 ) INTERFACE MODE -----	RGB 24BIT PARALLEL (DE/SYNC MODE)

MODEL NO.	VERSION	PAGE
ETM057010BDHU	2	2

2.2 CAPACITIVE TOUCH PANEL MECHANICAL SPECIFICATIONS

- (1) TOUCH PANEL SIZE ----- 5.7 inch
- (2) OUTER DIMENSION ----- 124.7W \* 100H \* 1.56D mm  
(WITHOUT FPC)
- (3) ACTIVE AREA ----- 116.57W \* 88.77H mm
- (4) INPUT TYPE ----- MULTI-TOUCH
- (5) NUMBER OF TOUCH SENSOR ----- 22\*16 SENSORS
- (6) INTERFACE MODE ----- I2C
- (7) RESOLUTION ----- 1408\*1024

CONFIDENTIAL  
Authorized for  
Emerging Display Technologies Corporation Only.  
Do not distribute without authorization.

### 3. ABSOLUTE MAXIMUM RATINGS

#### 3.1 LCD MODULE ELECTRICAL ABSOLUTE MAXIMUM RATINGS

VSS=0V

PARAMETER	SYMBOL	MIN.	MAX.	UNIT	REMARK
POWER SUPPLY VOLTAGE	VCC	-0.3	7.0	V	
	VDD	-0.3	7.0	V	
INPUT VOLTAGE	V <sub>in</sub>	-0.3	VCC+0.3	V	
LED BACKLIGHT DISSIPATION	PD	—	1.28	W	
LED BACKLIGHT CURRENT	IF	—	0.06	A	
LED BACKLIGHT REVERSE VOLTAGE	VR	—	45	V	

#### 3.2 CAPACITIVE TOUCH PANEL ELECTRICAL ABSOLUTE MAXIMUM RATINGS

PARAMETER	SYMBOL	MIN.	MAX.	UNIT	REMARK
POWER SUPPLY FOR DRIVER	VDD1-VSS1	-0.3	3.6	V	
INPUT VOLTAGE	VIN	-0.3	IOVCC+0.3	V	NOTE (1)

NOTE (1) : IOVCC IS SET TO VDD1 BY SOFTWARE CONFIGURATION.

#### 3.3 ENVIRONMENTAL ABSOLUTE MAXIMUM RATINGS

ITEM	OPERATING		STORAGE		REMARK
	MIN.	MAX.	MIN.	MAX.	
AMBIENT TEMPERATURE	-20°C	70°C	-30°C	80°C	NOTE (1), (2)
HUMIDITY	NOTE (3)		NOTE (3)		WITHOUT CONDENSATION
VIBRATION	—	2.45 m/s <sup>2</sup> (0.25 G)	—	11.76 m/s <sup>2</sup> (1.2 G)	10~100 Hz XYZ DIRECTIONS 1 Hr. EACH
SHOCK	—	29.4 m/s <sup>2</sup> (3 G)	—	490.0 m/s <sup>2</sup> (50 G)	10 ms XYZ DIRECTIONS 1 TIME EACH
CORROSIVE GAS	NOT ACCEPTABLE		NOT ACCEPTABLE		

NOTE (1) : Ta AT -30°C : 48HRS MAX.

80°C : 168HRS MAX.

NOTE (2) : BACKGROUND COLOR CHANGES SLIGHTLY DEPENDING ON AMBIENT TEMPERATURE  
THIS PHENOMENON IS REVERSIBLE.

NOTE (3) : Ta ≤ 60°C : 90%RH MAX (96HRS MAX.)

Ta > 60°C : ABSOLUTE HUMIDITY MUST BE LOWER THAN THE HUMIDITY OF 90%RH  
AT 60°C. (96HRS MAX.)

#### 4. ELECTRICAL CHARACTERISTICS

##### 4.1 LCD MODULE ELECTRICAL CHARACTERISTICS

Ta = 25 °C

PARAMETER	SYMBOL	CONDITION	MIN.	TYP.	MAX.	UNIT	REMARK
POWER SUPPLY VOLTAGE FOR VCOM	VCC	—	3	3.3	3.6	V	
POWER SUPPLY VOLTAGE FOR LCD	VDD	—	3	3.3	3.6	V	
POWER SUPPLY CURRENT FOR VCOM	ICC	VCC = 3.3V LED B/L = ON	—	510	600	mA	
POWER SUPPLY CURRENT FOR LCD	IDD	VDD = 3.3V	—	8	12	mA	NOTE(1)
LOW LEVEL INPUT VOLTAGE	VIL	—	0	—	0.3*VCC	V	NOTE(2)
HIGH LEVEL INPUT VOLTAGE	VIH	—	0.7*VCC	—	VCC	V	NOTE(2)
FRAME FREQUENCY	fFRAME	—	50	60	72	Hz	
LED LIFE TIME	—	I <sub>LED</sub> =20mA (PER.LED)	30K	—	—	hrs	NOTE(3) NOTE(4)

NOTE ( 1 ) : THE DISPLAY PATTERN IS ALL “WHITE”.

NOTE ( 2 ) : APPLIED TO TERMINALS /RESET, B0~B7, G0~G7, R0~R7, DCLK, HSYNC, VSYNC, ENB.

NOTE ( 3 ) : CONDITIONS; TA=25 °C, CONTINUOUS LIGHTING

NOTE ( 4 ) : DEFINITIONS OF FAILURE

A. LCD LUMINANCE BECOMES HALF OF THE MINIMUM VALUE.

B. LED DOESN'T LIGHT NORMALLY

NOTE ( 5 ) : AMBIENT TEMP. VS. ALLOWABLE FORWARD CURRENT. (PER LED)

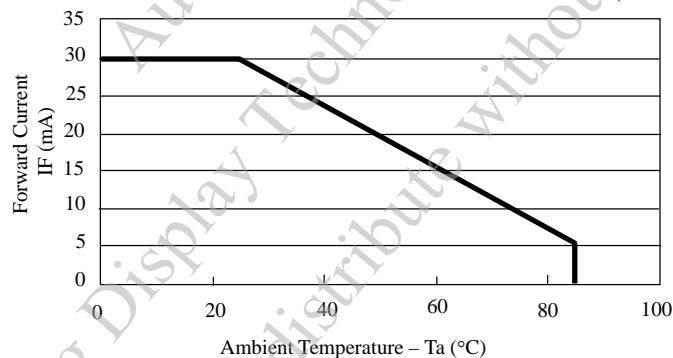

##### 4.2 CAPACITIVE TOUCH PANEL ELECTRICAL CHARACTERISTICS

Ta=25°C

ITEM	SYMBOL	CONDITION	MIN.	TYP.	MAX.	UNIT
POWER SUPPLY FOR DRIVER	VDD1-VSS1	—	2.8	3.3	3.6	V
POWER SUPPLY CURRENT CONSUMPTION FOR OPERATION	I <sub>DD1</sub>	VDD1=3.3V	—	13	20	mA
POWER SUPPLY CURRENT CONSUMPTION FOR SLEEP MODE	I <sub>SB</sub>	VDD1=3.3V	—	50	100	μA
INPUT HIGH-LEVEL VOLTAGE	VIH	—	0.7*IOVCC	—	IOVCC	V
INPUT LOW-LEVEL VOLTAGE	VIL	—	-0.3	—	0.3*IOVCC	V
OUTPUT HIGHT-LEVEL VOLTAGE	VOH	IOH=-0.1mA	0.7*IOVCC	—	—	V
OUTPUT LOW-LEVEL VOLTAGE	VOL	IOH=0.1mA	—	—	0.3*IOVCC	V

5. TIMING CHARACTERISTICS

5.1 LCD MODULE DIGITAL PARALLEL RGB INTERFACE (SYNC MODE)

ITEM	SYMBOL	MIN.	TYP.	MAX.	UNIT
DCLK FREQUENCY	$F_{CPH}$	22.66	25.175	27.69	MHz
DCLK PERIOD	$T_{CPH}$	36.11	39.7	44.13	ns
DCLK PULSE DUTY	$T_{CWH}$	40	50	60	%
HSYNC PERIOD	$T_H$	750	800	850	$T_{CPH}$
HSYNC PULSE WIDTH	$T_{WH}$	5	30	—	$T_{CPH}$
HSYNC FIRST HORIZONTAL DATA TIME	$T_{HS}$	112	144	175	$T_{CPH}$
HORIZONTAL ACTIVE DATA AREA	$T_{HA}$	—	640	—	$T_{CPH}$
VSYNC PULSE WIDTH	$T_{WV}$	1	3	5	$T_H$
FIRST LINE DATA INPUT TIME	$T_{STV}$	—	35	—	$T_H$
VSYNC PERIOD	$T_V$	515	525	535	$T_H$

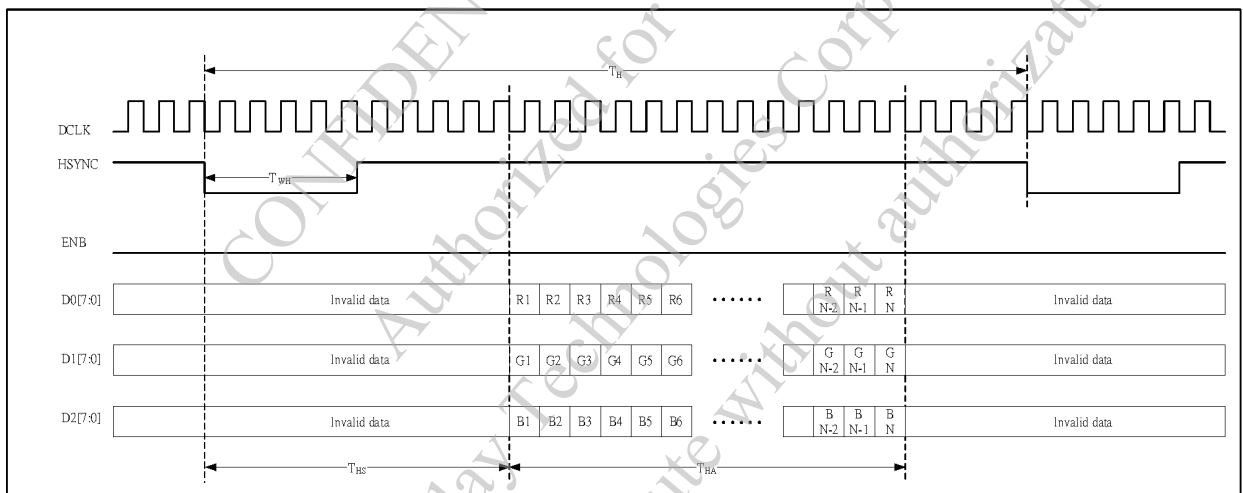

HORIZONTAL TIMING

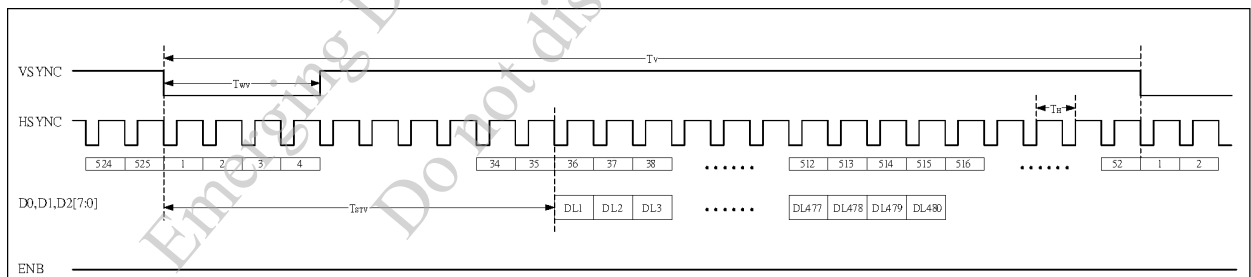

VERTICAL TIMING



5.2 LCD MODULE DIGITAL PARALLEL RGB INTERFACE (DE MODE)

ITEM	SYMBOL	MIN.	TYP.	MAX.	UNIT
DCLK FREQUENCY	$F_{CPH}$	22.66	25.175	27.69	MHz
DCLK PERIOD	$T_{CPH}$	36.11	39.7	44.13	ns
DCLK PULSE DUTY	$T_{CWH}$	40	50	60	%
ENB PERIOD	$T_{DEN}$	750	800	850	$T_{CPH}$
ENB PULSE WIDTH	$T_{EP}$	—	640	—	$T_{CPH}$
ENB FRAME ACTIVE TIME	$T_{DEA}$	—	480	—	$T_H$
ENB FRAME BLANKING TIME	$T_{DEB}$	10	45	110	$T_H$

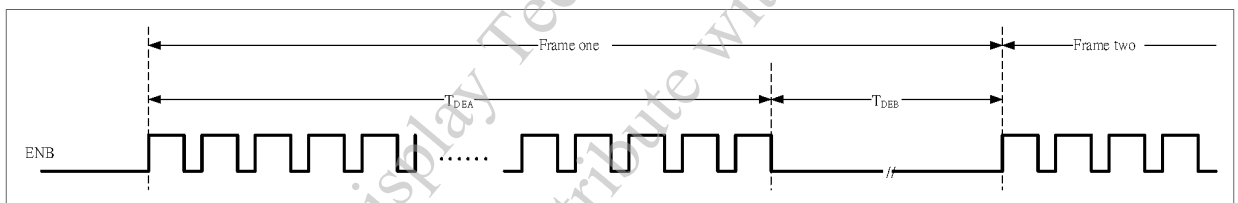
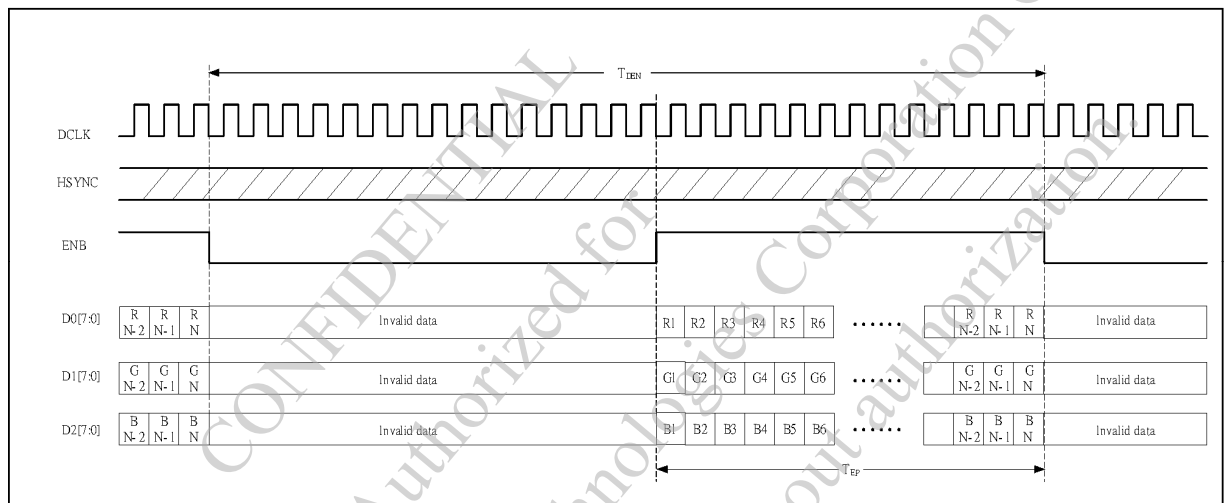

### 5.3 CAPACITIVE TOUCH PANEL MODULE I2C INTERFACE TIMING CHARACTERISTICS

ITEM	MIN.	TYP.	MAX.	UNIT
SCL FREQUENCY	0	—	400	KHz
BUS FREE TIME BETWEEN A STOP AND START CONDITION	4.7	—	—	us
HOLD TIME (REPEATED) START CONDITION	4.0	—	—	us
DATA SETUP TIME	250	—	—	ns
SETUP TIME FOR A REPEATED START CONDITION	4.7	—	—	us
SETUP TIME FOR STOP CONDITION	4.0	—	—	us

### 5.4 CAPACITIVE TOUCH PANEL MODULE I2C BUS TIMING

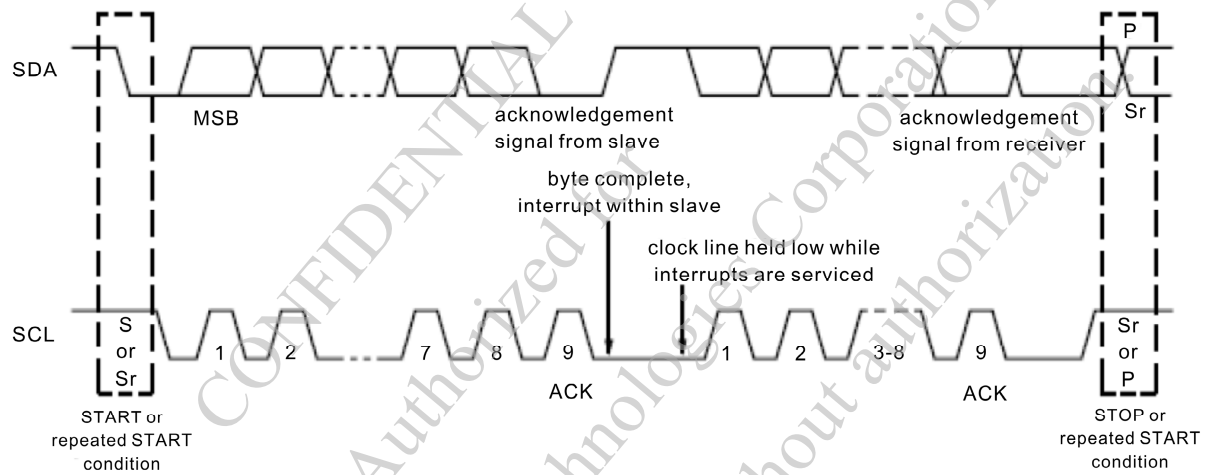

6. OPTICAL CHARACTERISTICS (NOTE1)

6.1 OPTICAL CHARACTERISTICS

Ta = 25 ± 2 °C

ITEM	SYMBOL	CONDITION	MIN.	TYP.	MAX.	UNIT	REMARK	
VIEWING ANGLE	$\theta_{y+}$	CR ≥ 10	$\theta_x=0^\circ$	50	55	—	deg.	(2) (3)
	$\theta_{y-}$			47	52	—		
	$\theta_{x+}$		$\theta_y=0^\circ$	60	65	—		
	$\theta_{x-}$			60	65	—		
CONTRAST RATIO	CR	$\theta_x=0^\circ, \theta_y=0^\circ$	300	350	—	—	(3)	
RESPONSE TIME	T <sub>R</sub> ( rise )	$\theta_x=0^\circ, \theta_y=0^\circ$	—	15	30	msec	(4)	
	T <sub>F</sub> ( fall )		—	35	50			
THE BRIGHTNESS OF MODULE	B	$\theta_x=0^\circ, \theta_y=0^\circ$ IF = 40mA	340	380	—	cd/m <sup>2</sup>	(5)	
COLOR OF CIE COORDINATE	WHITE	$\theta_x=0^\circ, \theta_y=0^\circ$ IF = 40mA NTSC : 50 %	W <sub>x</sub>	0.26	0.31	0.36	—	(6)
			W <sub>y</sub>	0.30	0.35	0.40		
	RED		R <sub>x</sub>	0.56	0.61	0.66		
			R <sub>y</sub>	0.31	0.36	0.41		
	GREEN		G <sub>x</sub>	0.28	0.33	0.38		
			G <sub>y</sub>	0.51	0.56	0.61		
	BLUE		B <sub>x</sub>	0.09	0.14	0.19		
			B <sub>y</sub>	0.07	0.12	0.17		
THE UNIFORMITY OF MODULE	—	IF=40mA	75	80	—	%	—	

NOTE (1) : TEST EQUIPMENT SETUP :

AFTER STABILIZING AND LEAVING THE PANEL ALONE AT A GIVEN TEMPERATURE FOR 30 MINUTES. MEASUREMENT SHOULD BE EXECUTED IN A STABLE, WINDLESS, AND DARK ROOM. OPTICAL SPECIFICATIONS ARE MEASURED BY TOPCON BM-7 (FAST) WITH A VIEWING ANGLE OF 1° AT A DISTANCE OF 50cm AND NORMAL DIRECTION.

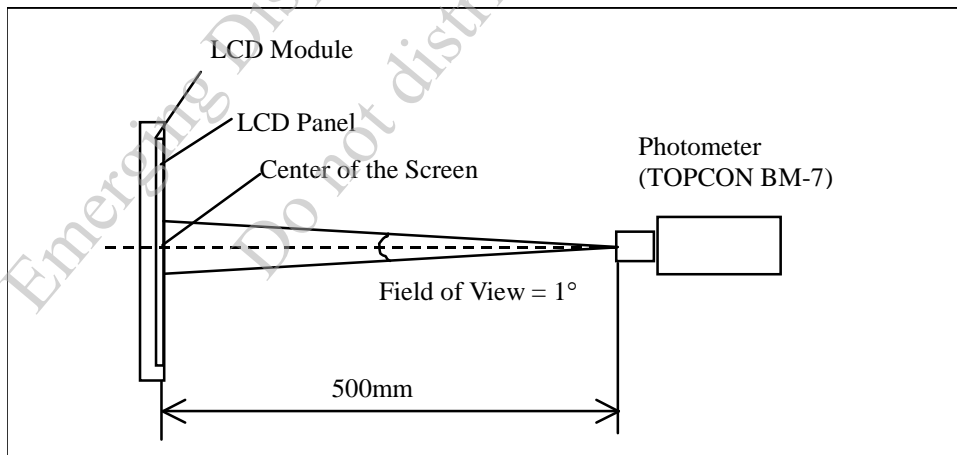

NOTE (2) : DEFINITION OF VIEWING ANGLE :

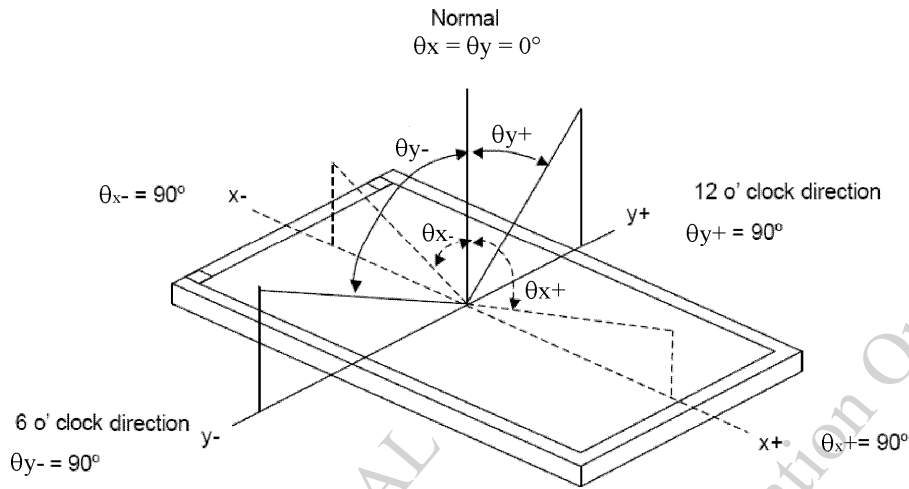

NOTE (3) : DEFINITION OF CONTRAST RATIO :

$$\text{CONTRAST RATIO (CR)} = \frac{\text{BRIGHTNESS MEASURED WHEN LCD IS AT "WHITE STATE"}}{\text{BRIGHTNESS MEASURED WHEN LCD IS AT "BLACK STATE"}}$$

NOTE (4) : DEFINITION OF RESPONSE TIME : TR AND TF

THE FIGURE BELOW IS THE OUTPUT SIGNAL OF THE PHOTO DETECTOR.

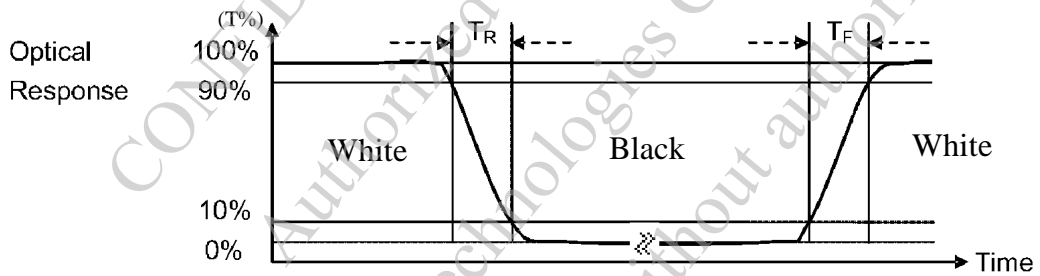

NOTE (5) : BRIGHTNESS MEASURED WHEN LCD IS AT "WHITE STATE"

NOTE (6) : THE 100% TRANSMISSION IS DEFINED AS THE TRANSMISSION OF LCD PANEL WHEN ALL THE INPUT TERMINALS OF MODULE ARE ELECTRICALLY OPENED.

## 6.2 THE TEST METHOD OF BRIGHTNESS AND UNIFORMITY

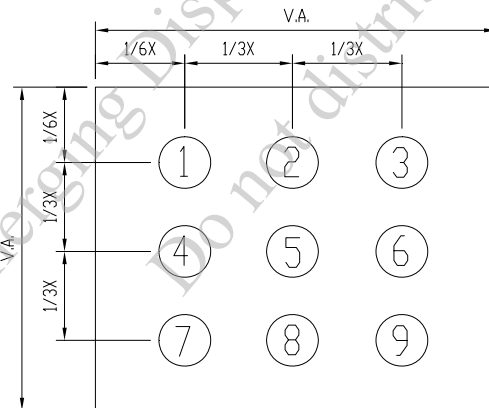

UNIT : mm

## 6.3 THE CALCULATING METHOD OF UNIFORMITY

$$\text{UNIFORMITY} = \left[ 1 - \frac{\text{MAXIMUM BRIGHTNESS} - \text{MINIMUM BRIGHTNESS}}{\text{AVERAGE BRIGHTNESS}} \right] \times 100\%$$

MODEL NO. ETM057010BDHU	VERSION 2	PAGE 10
----------------------------	--------------	------------

7. OUTLINE DIMENSIONS

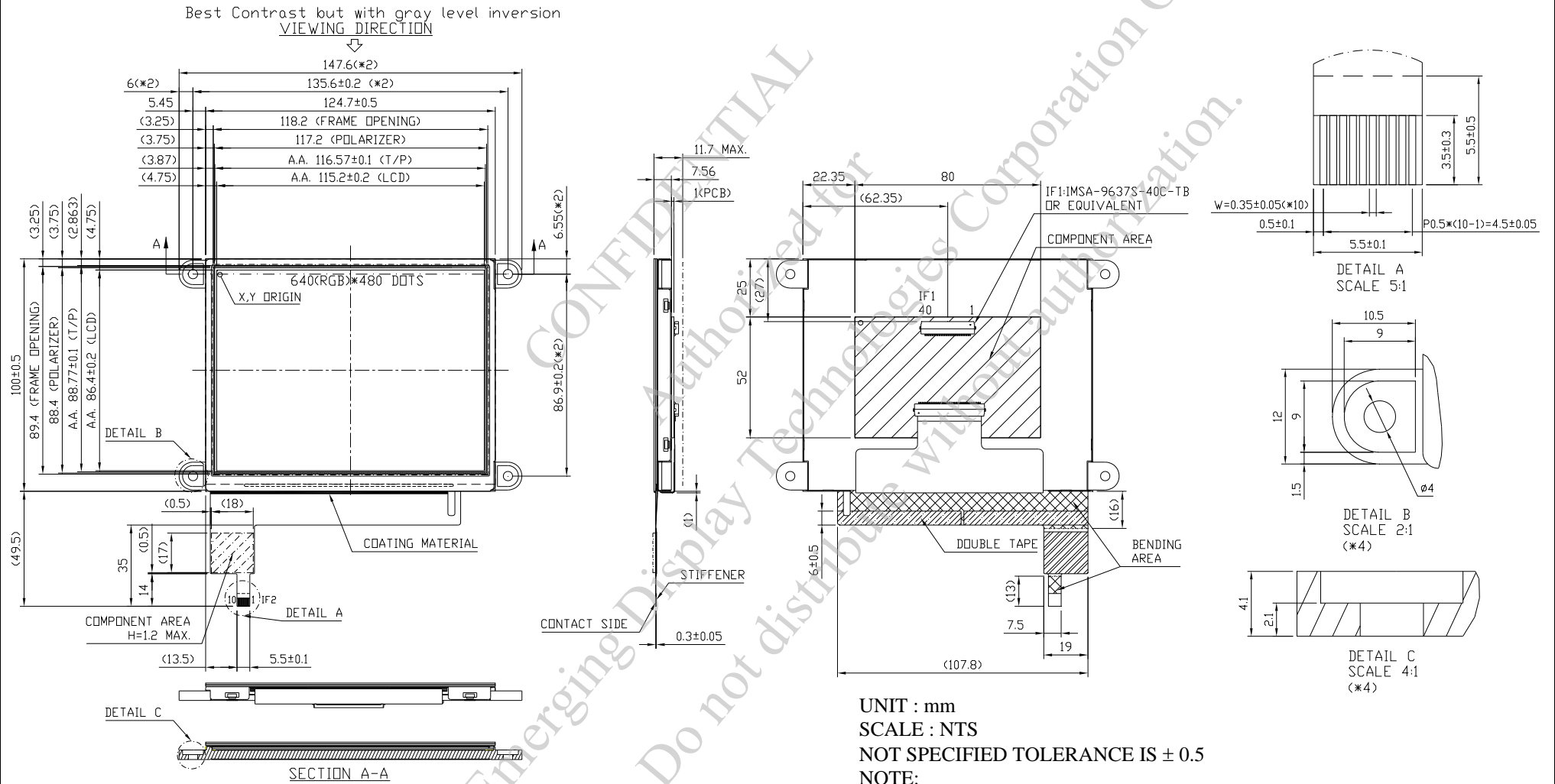

UNIT : mm  
SCALE : NTS  
NOT SPECIFIED TOLERANCE IS ± 0.5  
NOTE:  
1. IF2 RECOMMEND MATCH CONNECTOR KYOCERA:04 6240 010 SERIES

8. BLOCK DIAGRAM

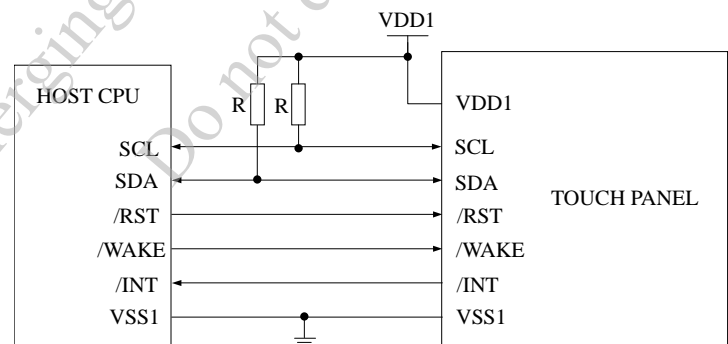
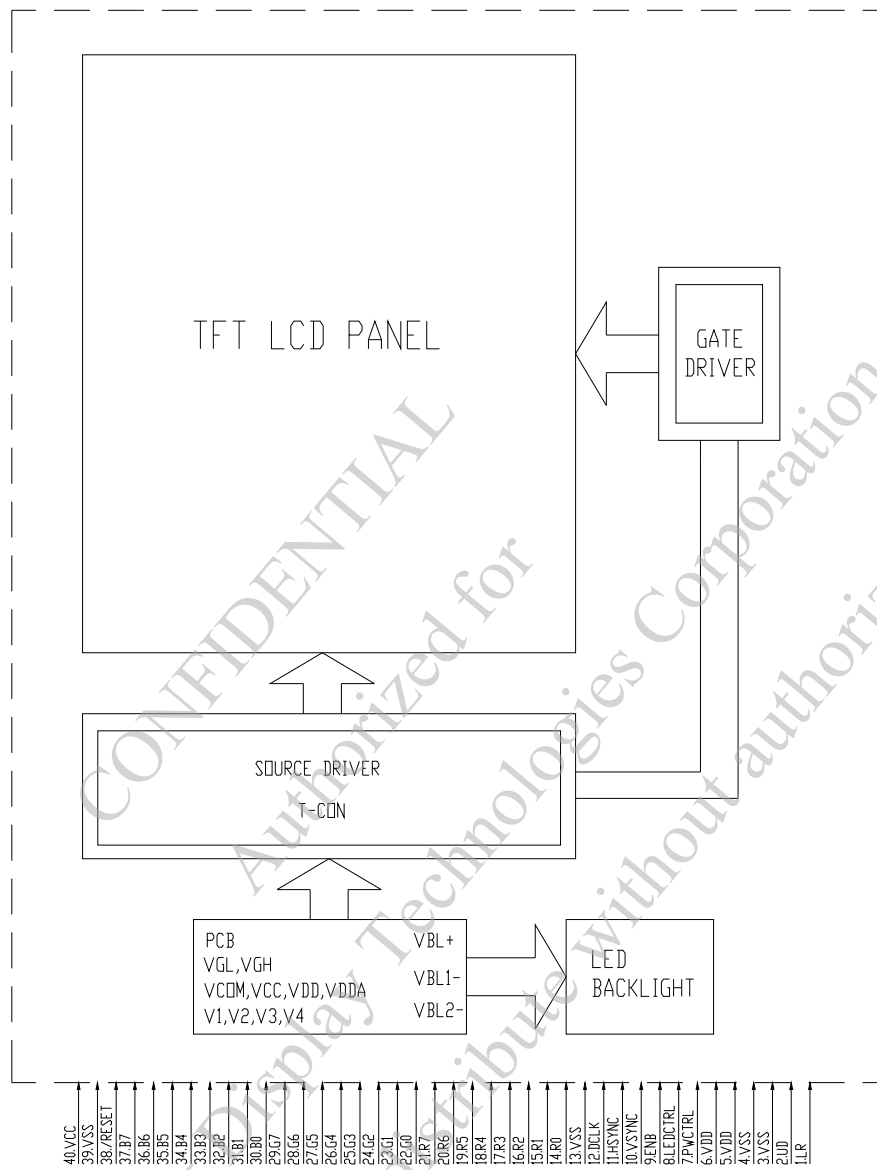

NOTE : VALUE OF PULL-UP RESISTORS(R) DEPENDS ON CLOCK SPEED, NUMBER OF CHIPS ON THE I2C BUS AND NOISE LEVEL. LOW SPEED 4.7K TO 10K OR HIGHER, HIGH SPEED 1K TO 4.7K OR HIGHER. SIGNALS SHOULD BE MEASURED WITH AN OSCILLOSCOPE TO VERIFY WAVEFORM AND HIGH / LOW LEVELS.

9. DETAIL DRAWING OF DOT MATRIX

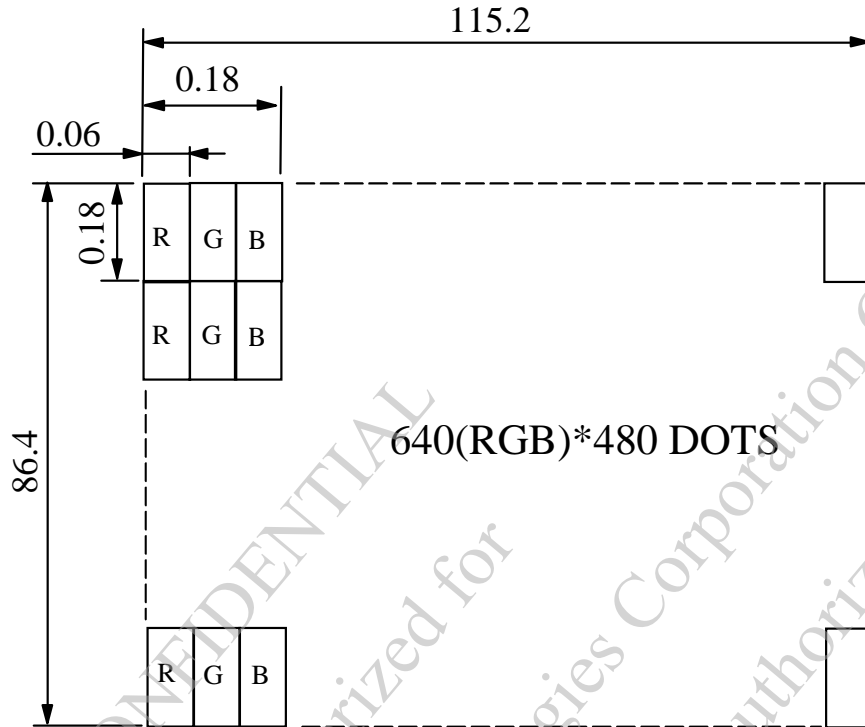

UNIT : mm  
 SCALE : NTS  
 NOT SPECIFIED TOLERANCE IS  $\pm 0.1$   
 DOTS MATRIX TOLERANCE IS  $\pm 0.01$

CONFIDENTIAL  
 Authorized for Emerging Display Technologies Corporation Only.  
 Do not distribute without authorization.

10. INTERFACE SIGNALS

10.1 CN1 SIGNAL INTERFACES

PIN NO.	SYMBOL	I/O	FUNCTION									
1	LR	I	LR=H:STH→S01→ ---- → S0960 → STHO LR=L:STH→S960→ ---- → S01 → STHO									
2	UD	I	UP/DOWN SCAN SETTING UD=H, REVERSE SCAN UD=L, NORMAL SCAN									
3, 4	VSS	P	GROUND									
5	VDD	P	POWER SUPPLY FOR DIGITAL CIRCUIT									
6	VDD	P	POWER SUPPLY FOR DIGITAL CIRCUIT									
7	PWCTRL	I	<table border="1"> <tr> <td rowspan="2">LOGIC LEVEL H=3.3V L=0V</td> <td>PWCTRL</td> <td>REMARK</td> </tr> <tr> <td>H</td> <td>POWER ON</td> </tr> <tr> <td>L</td> <td>SHUTDOWN</td> </tr> </table>	LOGIC LEVEL H=3.3V L=0V	PWCTRL	REMARK	H	POWER ON	L	SHUTDOWN		
					LOGIC LEVEL H=3.3V L=0V	PWCTRL	REMARK					
H	POWER ON											
L	SHUTDOWN											
8	LEDCTRL	I	BRIGHTNESS CONTROL FOR LED B/L									
9	ENB	I	DATA ENABLE INPUT	DE MODE & SYNC MODE SETTING DE MODE : ONLY ENB AND PIXEL CLOCK IS NECESSARY. SYNC MODE : ENB SHOULD BE CONNECTED TO VSS. HSYNC/YSYNC AND PIXEL CLOCK IS NECESSARY.								
10	VSYNC	I	VERTICAL SYNC INPUT									
11	HSYNC	I	HORIZONTAL SYNC INPUT									
12	DCLK	I	DOT DATA COLOCK									
13	VSS	P	GROUND									
14	R0	I	RED DATA BIT 0									
15	R1	I	RED DATA BIT 1									
16	R2	I	RED DATA BIT 2									
17	R3	I	RED DATA BIT 3									
18	R4	I	RED DATA BIT 4									
19	R5	I	RED DATA BIT 5									
20	R6	I	RED DATA BIT 6									
21	R7	I	RED DATA BIT 7									
22	G0	I	GREEN DATA BIT 0									
23	G1	I	GREEN DATA BIT 1									
24	G2	I	GREEN DATA BIT 2									
25	G3	I	GREEN DATA BIT 3									
26	G4	I	GREEN DATA BIT 4									
27	G5	I	GREEN DATA BIT 5									
28	G6	I	GREEN DATA BIT 6									
29	G7	I	GREEN DATA BIT 7									
30	B0	I	BLUE DATA BIT 0									



PIN NO.	SYMBOL	I/O	FUNCTION
31	B1	I	BLUE DATA BIT 1
32	B2	I	BLUE DATA BIT 2
33	B3	I	BLUE DATA BIT 3
34	B4	I	BLUE DATA BIT 4
35	B5	I	BLUE DATA BIT 5
36	B6	I	BLUE DATA BIT 6
37	B7	I	BLUE DATA BIT 7
38	/RESET	I	HARDWARE RESET
39	VSS	P	GROUND
40	VCC	P	POWER SUPPLY FOR VCOM DRIVER CIRCUIT

## 10.2 CN2 SIGNAL INTERFACES

PIN NO.	SYMBOL	FUNCTION
1	VSS1	GROUND
2	VDD1	POWER SUPPLY VOLTAGE
3	SCL	I2C CLOCK INPUT
4	NC	NON CONNECTION
5	SDA	I2C DATA INPUT AND OUTPUT
6	NC	NON CONNECTION
7	/RST	EXTERNAL RESET, LOW IS ACTIVE
8	/WAKE	FOR EDT INTERNAL USE (CUSTOMER DON'T USE)
9	/INT	EXTERNAL INTERRUPT TO THE HOST
10	VSS1	GROUND

## 11. POWER SUPPLY

### 11.1 POWER SUPPLY FOR LCM

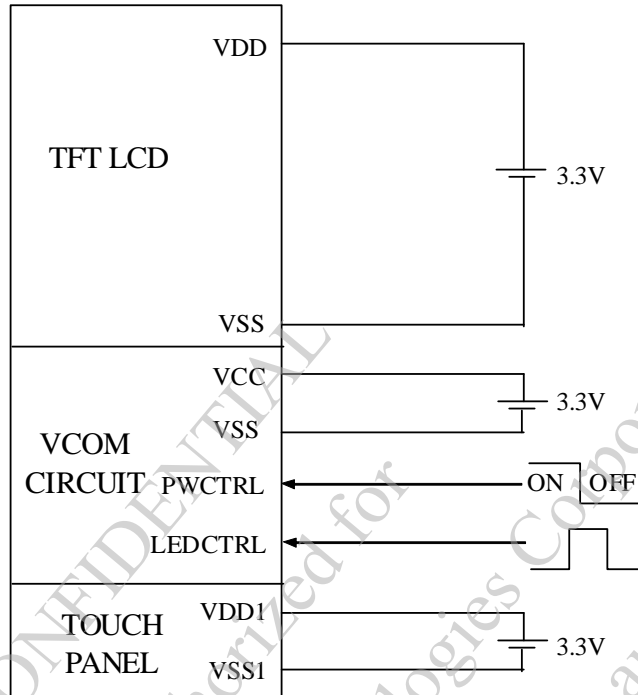

### 11.2 THE BRIGHTNESS CONTROLLED BY PWM SIGNAL OF LEDCTRL

11.2.1 IF THE DUTY IS BIGGER, THE BRIGHTNESS WILL BE LOWER.

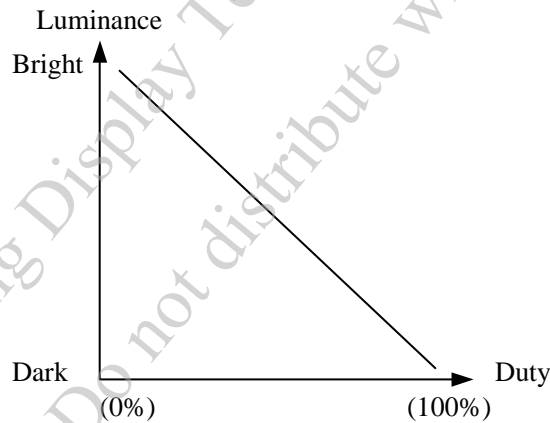

11.2.2 SIGNAL OPERATION FREQUENCY IS 1K ~ 2KHz.

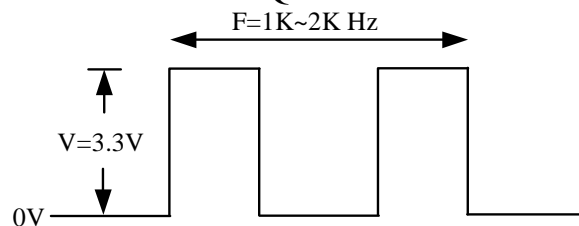

12. CAPACITIVE TOUCH PANEL SPECIFICATION

12.1 HARDNESS

ITEM	DESCRIPTION
SURFACE HARDNESS	7H (MIN.)

12.2 PROTOCOL

12.2.1 I2C READ

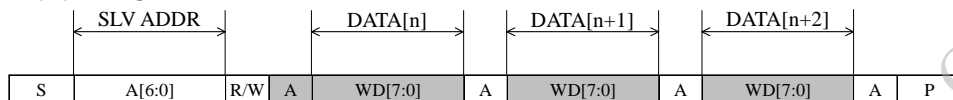

CHARACTER	DESCRIPTION
S	I2C START OR I2C RESTART
A[6:0]	SLAVE ADDRESS
R /W	“1”=READ ; “0”=WRITE
A	ACK SIGNAL
P	STOP SIGNAL (STOP SIGNAL IS OPTIONAL, RESTART SIGNAL IS ALSO OK FOR NEXT PACKET)

SLAVE ADDRESS=0x38

12.2.2 INTERRUPT SIGNAL FROM CTPM TO HOST

AS FOR STANDARD CTPM, HOST NEED TO USE BOTH INTERRUPT CONTROL SIGNAL AND SERIAL DATA INTERFACE TO GET THE TOUCH DATA.

HERE IS THE TIMING TO GET TOUCH DATA

WRITE N BYTES TO I2C SLAVE

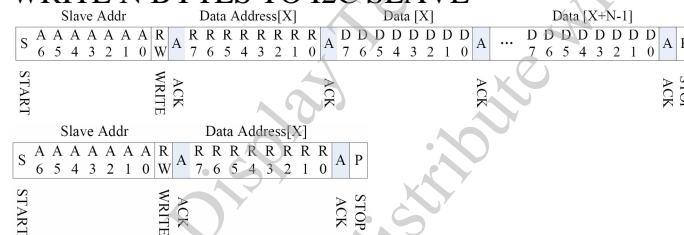

READ X BYTES FROM I2C SLAVE

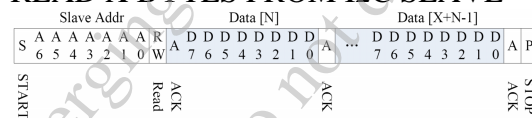

12.2.3 INTERRUPT SIGNAL FROM CTPM TO HOST

AS FOR STANDARD CTPM, HOST NEED TO USE BOTH INTERRUPT CONTROL SIGNAL AND SERIAL DATA INTERFACE TO GET THE TOUCH DATA. HERE IS THE TIMING TO GET TOUCH DATA.

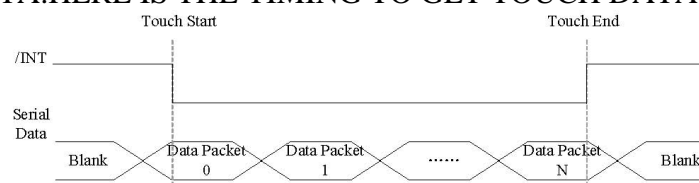



TOUCH DATA READ PROTOCOL

NAME	VALUE	DESCRIPTION
START CH	0xF9	START COMMAND FOR CTPM TOUCH DATA PACKET, HOST MUST SEND CTPM A START CH COMMAND BEFORE READ TOUCH DATA
1st READ BYTE ~ LAST READ BYTE		TOUCH DATA PACKET SENT BY CTPM, EACH BYTE HAS 8-BIT DATA, A TOUCH DATA PACKET CONSISTS OF N BYTE.

A DATA PACKET STARTS WITH A HEADER AND ENDS WITH CRC CODE. AS FOR 5 POINTS DATA PACKET, THE LENGTH OF THE PACKET IS ALWAYS 26 BYTES IN SPITE OF ACTUAL TOUCH POINTS.

NAME	LENGTH (BYTE)	VALUE	DESCRIPTION
HEAD	2	0xAAAA	HEADER OF TOUCH DATA
BYTE0	1	0b00xx_xxxx	THE PACKET LENGTH WHICH STORES IN THE LOWER 6 BIT, 26 HERE.
BYTE1	1	0b0000_xxxx	ACTUAL TOUCH POINTS WHICH STORES IN THE LOWER 4 BIT.
BYTE2	1	0x00	RESERVED.
X1	2	0x0XXX	HORIZONTAL COORDINATE OF TOUCH POINT 1(12 BIT), CORRESPONDING TO THE HORIZONTAL CORRDATE OF DISPLAY SCREEN.
Y1	2	0x0XXX	VERTICAL COORDINATE OF TOUCH POINT 1(12 BIT), CORRESPONDING TO THE HORIZONTAL CORRDATE OF DISPLAY SCREEN.
X2	2	0x0XXX	HORIZONTAL COORDINATE OF TOUCH POINT 2
Y2	2	0x0XXX	VERTICAL COORDINATE OF TOUCH POINT 2
X3	2	0x0XXX	HORIZONTAL COORDINATE OF TOUCH POINT 3
Y3	2	0x0XXX	VERTICAL COORDINATE OF TOUCH POINT 3
X4	2	0x0XXX	HORIZONTAL COORDINATE OF TOUCH POINT 4
Y4	2	0x0XXX	VERTICAL COORDINATE OF TOUCH POINT 4
X5	2	0x0XXX	HORIZONTAL COORDINATE OF TOUCH POINT 5
Y5	2	0x0XXX	VERTICAL COORDINATE OF TOUCH POINT 5
CRC	1	0xXXX	CRC CODE FOR PREVIOUS N-1 DATA, FOR THE DATA VALIDATION. CRC CODE IS EQUAL TO THE XOR RESULT OF PREVIOUS 25 BYTE.

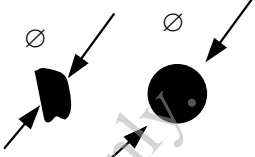
12.3 INSPECTION STANDARDS

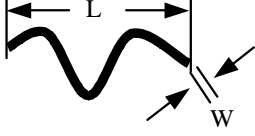
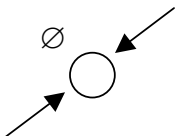
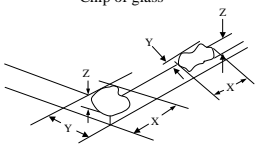
INSPECTION ITEMS	CRITERIA	REMARK								
BLACK/WHITE SPOT	THE FOLLOWING BLACK/WHITE SPOT ARE WITHIN THE VIEWING AREA. AVERAGE DIAMETER : D (mm)									
	<table border="1"> <thead> <tr> <th>SIZE D</th> <th>PERMISSIBLE NO.</th> </tr> </thead> <tbody> <tr> <td><math>D \leq 0.1\text{mm}</math></td> <td>IGNORE</td> </tr> <tr> <td><math>0.1\text{mm} &lt; D \leq 0.3\text{mm}</math></td> <td>5</td> </tr> <tr> <td><math>0.3\text{mm} &lt; D \leq 0.5\text{mm}</math></td> <td>5</td> </tr> <tr> <td><math>D &gt; 0.5\text{mm}</math></td> <td>0</td> </tr> </tbody> </table>		SIZE D	PERMISSIBLE NO.	$D \leq 0.1\text{mm}$	IGNORE	$0.1\text{mm} < D \leq 0.3\text{mm}$	5	$0.3\text{mm} < D \leq 0.5\text{mm}$	5
SIZE D	PERMISSIBLE NO.									
$D \leq 0.1\text{mm}$	IGNORE									
$0.1\text{mm} < D \leq 0.3\text{mm}$	5									
$0.3\text{mm} < D \leq 0.5\text{mm}$	5									
$D > 0.5\text{mm}$	0									
	NOTE (1) : THE DISTANCE BETWEEN DOT EDFFECTS SHOULD BE MORE THAN 10mm APART.									
SCRATCH	THE FOLLOWING BLACK LINE, WHITE LINE IS WITHIN THE VIEWING AREA. WIDTH : W (mm) , LENGH : L (mm)									
	<table border="1"> <thead> <tr> <th>SIZE W &amp; L</th> <th>PERMISSIBLE NO.</th> </tr> </thead> <tbody> <tr> <td><math>W \leq 0.05\text{mm}</math></td> <td>IGNORE</td> </tr> <tr> <td><math>0.05\text{mm} &lt; W \leq 0.07\text{mm}, L \leq 5\text{mm}</math></td> <td>1</td> </tr> <tr> <td><math>W &gt; 0.07\text{mm}</math></td> <td>0</td> </tr> </tbody> </table>		SIZE W & L	PERMISSIBLE NO.	$W \leq 0.05\text{mm}$	IGNORE	$0.05\text{mm} < W \leq 0.07\text{mm}, L \leq 5\text{mm}$	1	$W > 0.07\text{mm}$	0
SIZE W & L	PERMISSIBLE NO.									
$W \leq 0.05\text{mm}$	IGNORE									
$0.05\text{mm} < W \leq 0.07\text{mm}, L \leq 5\text{mm}$	1									
$W > 0.07\text{mm}$	0									
LINEAR TYPE / FOREIGN FIBER	THE FOLLOWING BLACK LINE, WHITE LINE IS WITHIN THE VIEWING AREA. WIDTH : W (mm) , LENGH : L (mm)									
	<table border="1"> <thead> <tr> <th>SIZE W &amp; L</th> <th>PERMISSIBLE NO.</th> </tr> </thead> <tbody> <tr> <td><math>W \leq 0.05\text{mm}</math></td> <td>IGNORE</td> </tr> <tr> <td><math>0.05\text{mm} &lt; W \leq 0.07\text{mm}, L \leq 5\text{mm}</math></td> <td>1</td> </tr> <tr> <td><math>W &gt; 0.07\text{mm}</math></td> <td>0</td> </tr> </tbody> </table>		SIZE W & L	PERMISSIBLE NO.	$W \leq 0.05\text{mm}$	IGNORE	$0.05\text{mm} < W \leq 0.07\text{mm}, L \leq 5\text{mm}$	1	$W > 0.07\text{mm}$	0
SIZE W & L	PERMISSIBLE NO.									
$W \leq 0.05\text{mm}$	IGNORE									
$0.05\text{mm} < W \leq 0.07\text{mm}, L \leq 5\text{mm}$	1									
$W > 0.07\text{mm}$	0									
BUBBLE / DENT	BUBBLES WITHIN VIEWING AREA. AVERAGE DIAMETER : D (mm)									
	<table border="1"> <thead> <tr> <th>SIZE D</th> <th>PERMISSIBLE NO.</th> </tr> </thead> <tbody> <tr> <td><math>W \leq 0.2\text{mm}</math></td> <td>IGNORE</td> </tr> <tr> <td><math>0.2\text{mm} &lt; W \leq 0.3\text{mm}</math></td> <td>3</td> </tr> <tr> <td><math>0.3\text{mm} &lt; W \leq 0.5\text{mm}</math></td> <td>1</td> </tr> <tr> <td><math>W &gt; 0.5\text{mm}</math></td> <td>0</td> </tr> </tbody> </table>		SIZE D	PERMISSIBLE NO.	$W \leq 0.2\text{mm}$	IGNORE	$0.2\text{mm} < W \leq 0.3\text{mm}$	3	$0.3\text{mm} < W \leq 0.5\text{mm}$	1
SIZE D	PERMISSIBLE NO.									
$W \leq 0.2\text{mm}$	IGNORE									
$0.2\text{mm} < W \leq 0.3\text{mm}$	3									
$0.3\text{mm} < W \leq 0.5\text{mm}$	1									
$W > 0.5\text{mm}$	0									
CHIP DAMAGE ON GLASS	CORNER									
	EDGE									

NOTE :

- 1.FOR ANY SPOTS OR LINES, WHICH ARE NOT OBSERVED UNDER APPROPRIATE PANEL OPERATING CONDITION ARE DEEMED ACCEPTABLE.
- 2.THE FOREIGN MATERIALS THAT CAN BE BLOWN OUT BY AIR AND REMOVED BY WET CLEANING ARE NOT REGARDED AS DEFECTS.

13. INSPECTION CRITERION

13.1 APPLICATION

THIS INSPECTION STANDARD IS TO BE APPLIED TO THE LCD MODULE DELIVERED FROM EMERGING DISPLAY TECHNOLOGIES CORP.( E.D.T ) TO CUSTOMERS

13.2 INSPECTION CONDITIONS

13.2.1 (1)OBSERVATION DISTANCE : 35cm±5cm

(2)VIEW ANGLE :

NON-OPERATION CONDITION : ±5°  
(PERPENDICULAR TO LCD PANEL SURFACE)

OPERATION CONDITION : ±45°  
(PERPENDICULAR TO LCD PANEL SURFACE)

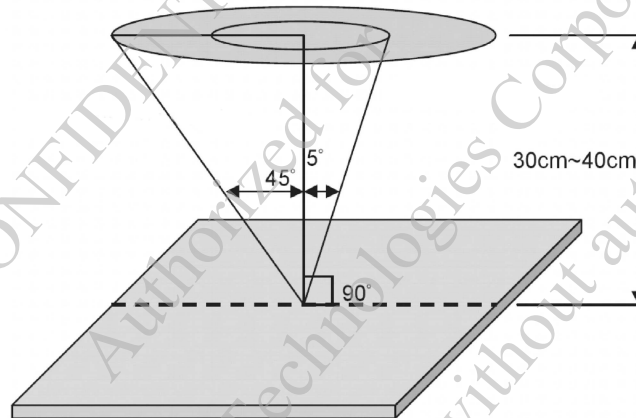

13.2.2 ENVIRONMENT CONDITIONS :

AMBIENT TEMPERATURE		20°C~25°C
AMBIENT HUMIDITY		65±20%RH
AMBIENT ILLUMINATION	COSMETIC INSPECTION	More than 600Lux
	FUNCTIONAL INSPECTION	300~500 Lux

13.2.3 INSPECTION LOT

QUANTITY PER DELIVERY LOT FOR EACH MODEL

13.2.4 INSPECTION METHOD

A SAMPLING INSPECTION SHALL BE MADE ACCORDING TO THE FOLLOWING PROVISIONS TO JUDGE THE ACCEPTABILITY

(a)APPLICABLE STANDARD : MIL-STD-105E  
NORMAL INSPECTION, SINGLE SAMPLING  
LEVEL II

(b)AQL : MAJOR DEFECT : AQL 0.65  
MINOR DEFECT : AQL 1.0

13.3 INSPECTION STANDARDS

13.3.1 VISUAL DEFECTS CLASSIFICATION

TYPE OF DEFECT	INSPECTION ITEM	DEFECT FEATURE	AQL
MAJOR DEFECT	1.DISPLAY ON	<ul style="list-style-type: none"> <li>• DEFECT TO MISS SPECIFIED DISPLAY FUNCTION, FOR ALL AND SPECIFIED DOTS</li> <li>EX: DISCONNECTION, SHORT CIRCUIT ETC</li> </ul>	0.65
	2.BACKLIGHT	<ul style="list-style-type: none"> <li>• NO LIGHT</li> <li>• FLICKERING AND OTHER ABNORMAL ILLUMINATION</li> </ul>	
	3.DIMENSIONS	<ul style="list-style-type: none"> <li>• SUBJECT TO INDIVIDUAL ACCEPTANCE SPECIFICATIONS</li> </ul>	
MINOR DEFECT	1.DISPLAY ZONE	<ul style="list-style-type: none"> <li>• BLACK/WHITE SPOT</li> <li>• BUBBLES ON POLARIZER</li> <li>• NEWTON RING</li> <li>• BLACK/WHITE LINE</li> <li>• SCRATCH</li> <li>• CONTAMINATION</li> <li>• LEVER COLOR SPREED</li> </ul>	1.0
	2.BEZEL ZONE	<ul style="list-style-type: none"> <li>• STAINS</li> <li>• SCRATCHES</li> <li>• FOREIGN MATTER</li> </ul>	
	3.SOLDERING	<ul style="list-style-type: none"> <li>• INSUFFICIENT SOLDER</li> <li>• SOLDERED IN INCORRECT POSITION</li> <li>• CONVEX SOLDERING SPOT</li> <li>• SOLDER BALLS</li> <li>• SOLDER SCRAPS</li> </ul>	
	4.DISPLAY ON (ALL ON)	<ul style="list-style-type: none"> <li>• LIGHT LINE</li> </ul>	

13.3.2 MODULE DEFECTS CALSSIFICATION

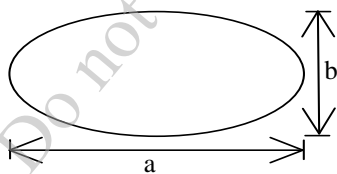
NO.	ITEM	CRITERIA												
1	DISPLAY ON INSPECTION	(1)INCORRECT PATTERN (2)MISSING SEGMENT (3)DIM SEGMENT (4)OPERATING VOLTAGE BEYOND SPEC												
2	OVERALL DIMENSIONS	(1)OVERALL DIMENSION BEYOND SPEC												
3	DOT DEFECT	(1) INSPECTION PATTERN: FULL WHITE, FULL BLACK, RED, GREEN AND BLUE SCREENS. (2) <table border="1" style="margin-left: 20px;"> <thead> <tr> <th>ITEMS</th> <th>ACCEPTABLE COUNT</th> </tr> </thead> <tbody> <tr> <td>BRIGHT DOT</td> <td><math>N \leq 2</math></td> </tr> <tr> <td>ARK DOT</td> <td><math>N \leq 3</math></td> </tr> <tr> <td>OAL BRIGHT AND DARK DOTS</td> <td><math>N \leq 4</math></td> </tr> </tbody> </table> <p>NOTE :</p> <p>1. THE DEFINITION OF DOT : THE SIZE OF A DEFECTIVE DOT OVER 1/2 OF WHOLE DOT IS REGARDED AS ONE DEFECTUVE DOT.</p> <p>2. BRIGHT DOT : DOTS APPEAR BRIGHT AND UNCHANGED IN SIZE IN WHICH LCD PANEL IS DISPLAYING UNDER BLACK PATTERN.</p> <p>3. DARK DOT : DOTS APPEAR DARK AND UNCHANGED IN SIZE IN WHICH LCD PANEL IS DISPLAYING UNDER PURE RED, GREEN, BLUE PICTURE.</p>	ITEMS	ACCEPTABLE COUNT	BRIGHT DOT	$N \leq 2$	ARK DOT	$N \leq 3$	OAL BRIGHT AND DARK DOTS	$N \leq 4$				
ITEMS	ACCEPTABLE COUNT													
BRIGHT DOT	$N \leq 2$													
ARK DOT	$N \leq 3$													
OAL BRIGHT AND DARK DOTS	$N \leq 4$													
4	FOREIGN BLACK/WHITE/ BRIGHT LINE/ SCRATCH OF VIEWING AREA	<table border="1" style="margin-left: 20px;"> <thead> <tr> <th>LENGTH : L</th> <th>WIDTH : W</th> <th>PERMISSIBLE NO.</th> </tr> </thead> <tbody> <tr> <td><math>L \leq 0.3</math></td> <td><math>W \leq 0.05</math></td> <td>IGNORE</td> </tr> <tr> <td><math>0.3 &lt; L \leq 2.5</math></td> <td><math>0.05 &lt; W \leq 0.1</math></td> <td>4</td> </tr> <tr> <td><math>2.5 &lt; L</math></td> <td><math>0.1 &lt; W</math></td> <td>NONE</td> </tr> </tbody> </table> <p>WIDTH : W mm, LENGH : L mm</p>	LENGTH : L	WIDTH : W	PERMISSIBLE NO.	$L \leq 0.3$	$W \leq 0.05$	IGNORE	$0.3 < L \leq 2.5$	$0.05 < W \leq 0.1$	4	$2.5 < L$	$0.1 < W$	NONE
LENGTH : L	WIDTH : W	PERMISSIBLE NO.												
$L \leq 0.3$	$W \leq 0.05$	IGNORE												
$0.3 < L \leq 2.5$	$0.05 < W \leq 0.1$	4												
$2.5 < L$	$0.1 < W$	NONE												
5	FOREIGN MATTER \ BLACK SPOTS \ WHITE SPOTS \ DENT (INCLUDING LIGHT LEAKAGE DUE TO POLARIZING PLATES PINHOLES, ETC.)	<table border="1" style="margin-left: 20px;"> <thead> <tr> <th>AVERAGE DIAMETER (mm): D</th> <th>NUMBER OF PIECES PERMITTED</th> </tr> </thead> <tbody> <tr> <td><math>D \leq 0.15</math></td> <td>IGNORE</td> </tr> <tr> <td><math>0.15 &lt; D \leq 0.5</math></td> <td>4</td> </tr> <tr> <td><math>0.5 &lt; D</math></td> <td>NONE</td> </tr> </tbody> </table> <p>NOTE : DIAMETER <math>D=(a+b)/2</math></p> 	AVERAGE DIAMETER (mm): D	NUMBER OF PIECES PERMITTED	$D \leq 0.15$	IGNORE	$0.15 < D \leq 0.5$	4	$0.5 < D$	NONE				
AVERAGE DIAMETER (mm): D	NUMBER OF PIECES PERMITTED													
$D \leq 0.15$	IGNORE													
$0.15 < D \leq 0.5$	4													
$0.5 < D$	NONE													

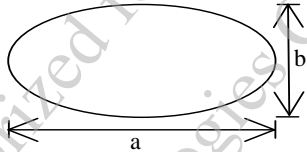

NO.	ITEM	CRITERIA		
			AVERAGE DIAMETER (mm) : D	NUMBER OF PIECES PERMITTED
6	BUBBLES OF POLARIZER /DIRT/CF FAIL /SURFACE STAINS	BUBBLE ON THE POLARIZER	$D \leq 0.25$	IGNORE
			$0.25 < D \leq 0.5$	$N \leq 5$
			$0.5 < D$	NOTE
		SURFACE STATUS	$D < 0.1 \text{ mm}$	IGNORE
			$0.1 < D \leq 0.3\text{mm}$	$N \leq 3$
		CF FAIL / SPOT	$D < 0.1 \text{ mm}$	IGNORE
$0.1 < D \leq 0.3\text{mm}$	$N \leq 3$			
		<p>NOTE : (1)POLARIZER BUBBLE IS DEFINED AS THE BUBBLE APPEARS ON ACTIVE DISPLAY AREA. THE DEFECT OF POLARIZER BUBBLE SHALL BE IGNORED IF THE POLARIZER BUBBLE APPEARS ON THE OUTSIDE OF ACTIVE DISPLAY AREA.</p> <p>(2)THE EXTRANEIOUS SUBSTANCE IS DEFINED AS IT CAN BE OBSERVED WHEN THE MODULE IS POWER ON.</p> <p>(3)THE DEFINITION OF AVERAGE DIAMETER, D IS DEFINED AS FOLLOWING.</p> <p>AVERAGE DIAMETER (D)=(a+b)/2</p> 		
7	LINE DEFECT ON DISPLAY	OBVIOUS VERTICAL OR HORIZONTAL LINE DEFECT IS NOT ALLOW		
8	MURA ON DISPLAY	IT'S OK IF MURA IS SLIGHT VISIBLE THROUG 6% ND FILTER		
9	UNEVEN COLOR SPREAD, COLORATION	(1)TO BE DETERMINED BASED UPON THE STANDARD SAMPLE.		
10	BEZEL APPEARANCE	(1)BEZEL MAY NOT HAVE RUST, BE DEFORMED OR HAVE FINGER PRINTS STAINS OF OTHER CONTAMINATION. (2)BEZEL MUST COMPLY WITH JOB SPECIFICATIONS.		
11	PCB	<p>(1)THERE MAY NOT BE MORE THAN 2mm OF SEALANT OUTSIDE THE SEAL AREA ON THE PCB, AND THERE SHOULD BE NO MORE THAN THREE PLACES.</p> <p>(2)NO OXIDATION OR CONTAMINATION PCB TERMINALS.</p> <p>(3)PARTS ON PCB MUST BE THE SAME AS ON THE PRODUCTION CHARACTERISTIC CHART. THERE SHOULD BE NO WRONG PARTS, MISSING PARTS OR EXCESS PARTS.</p> <p>(4)THE JUMPER ON THE PCB SHOULD CONFORM TO THE PRODUCT CHARACTERISTIC CHART.</p> <p>(5)IF SOLDER GETS ON BEZEL TAB PADS, LED PAD, ZEBRA PAD OR SCREW HOLD PAD; MAKE SURE IT IS SMOOTHED DOWN.</p>		

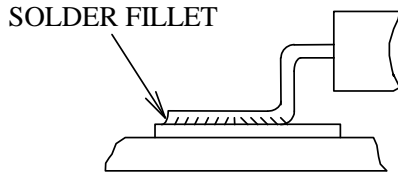
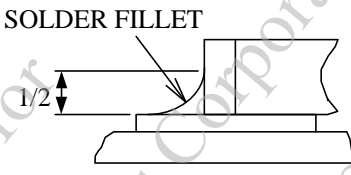
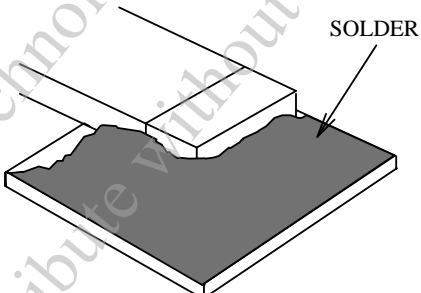
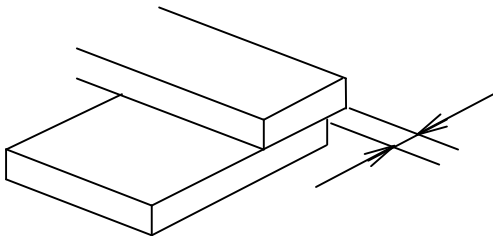
NO.	ITEM	CRITERIA
12	SOLDERING	<p>(1)NO SOLDERING FOUND ON THE SPECIFIED PLACE (2)INSUFFICIENT SOLDER</p> <p>(a)LSI, IC A POOR WETTING OF SOLDER IS BETWEEN LOWER BEND OR "HEEL" OF LEAD AND PAD</p>  <p>(b)CHIP COMPONENT · SOLDER IS LESS THAN 50% OF SIDES AND FRONT FACE WETTING</p>  <p>· SOLDER WETS 3 SIDES OF TERMINAL, BUT LESS THAN 25% OF SIDES AND FRONT SURFACE AREA ARE COVERED</p>  <p>(3)PARTS ALIGMENT (a)LSI, IC LEAD WIDTH IS MORE THAN 50% BEYOND PAD OUTLINE</p> 

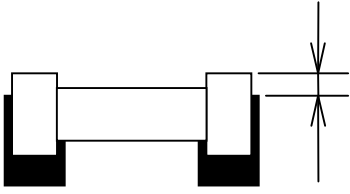
NO.	ITEM	CRITERIA
12	SOLDERING	<p>(b)CHIP COMPONENT COMPONENT IS OFF CENTER, AND MORE THAN 50% OF THE LEADS IS OFF THE PAD OUTLINE</p>  <p>(4)NO UNMELTED SOLDER PASTE MAY BE PRESENT ON THE PCB.                      (5)NO COLD SOLDER JOINTS, MISSING SOLDER CONNECTIONS, OXIDATION OR ICICLE.                      (6)NO RESIDUE OR SOLDER BALLS ON PCB.                      (7)NO SHORT CIRCUITS IN COMPONENTS ON PCB.</p>
13	BACKLIGHT	<p>(1)NO LIGHT                      (2)FLICKERING AND OTHER ABNORMAL ILLUMINATION                      (3)SPOTS OR SCRATCHES THAT APPEAR WHEN LIT MUST BE JUDGED USING LCD SPOT, LINES AND CONTAMINATION STANDARDS.                      (4)BACKLIGHT DOESN'T LIGHT OR COLOR IS WRONG.</p>
14	GENERAL APPEARANCE	<p>(1)NO OXIDATION, CONTAMINATION, CURVES OR, BENDS ON INTERFACE PIN (OLB) OF TCP.                      (2)NO CRACKS ON INTERFACE PIN (OLB) OF TCP.                      (3)NO CONTAMINATION, SOLDER RESIDUE OR SOLDER BALLS ON PRODUCT.                      (4)THE IC ON THE TCP MAY NOT BE DAMAGED, CIRCUITS.                      (5)THE UPPERMOST EDGE OF THE PROTECTIVE STRIP ON THE INTERFACE PIN MUST BE PRESENT OR LOOK AS IF IT CAUSE THE INTERFACE PIN TO SEVER.                      (6)THE RESIDUAL ROSIN OR TIN OIL OF SOLDERING (COMPONENT OR CHIP COMPONENT) IS NOT BURNED INTO BROWN OR BLACK COLOR.                      (7)SEALANT ON TOP OF THE ITO CIRCUIT HAS NOT HARDENED.                      (8)PIN TYPE MUST MATCH TYPE IN SPECIFICATION SHEET.                      (9)LCD PIN LOOSE OR MISSING PINS.                      (10)PRODUCT PACKAGING MUST THE SAME AS SPECIFIED ON PACKAGING SPECIFICATION SHEET.                      (11)PRODUCT DIMENSION AND STRUCTURE MUST CONFORM TO PRODUCT SPECIFICATION SHEET.                      (12)THE APPEARANCE OF HEAT SEAL SHOULD NOT ADMIT ANY DIRT AND BREAK.</p>

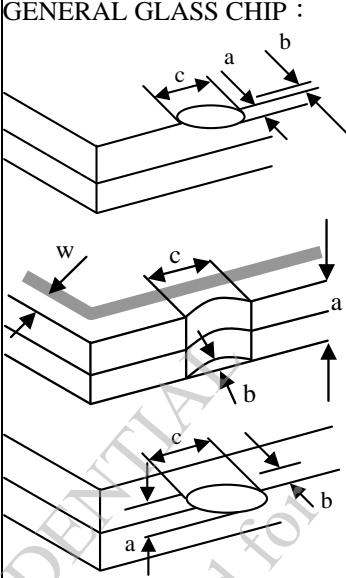
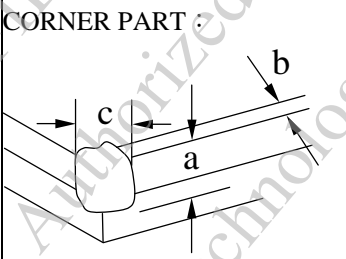
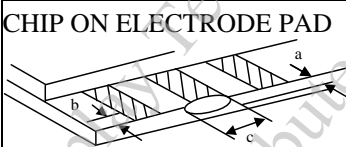
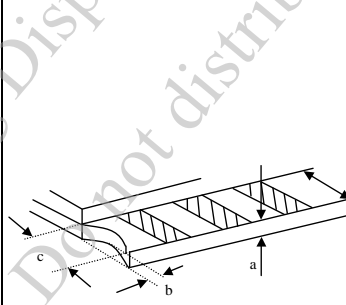
NO.	ITEM	CRITERIA									
15	CRACKED GLASS	<p>THE LCD WITH EXTENSIVE CRACK IS NOT ACCEPTABLE</p> <p>GENERAL GLASS CHIP :</p>  <table border="1"> <thead> <tr> <th>a</th> <th>b</th> <th>c</th> </tr> </thead> <tbody> <tr> <td><math>\leq t/2</math></td> <td>&lt; VIEWING AREA</td> <td><math>\leq 1/8X</math></td> </tr> <tr> <td><math>t/2 &gt; , \leq 2t</math></td> <td><math>\leq W/2</math></td> <td><math>\leq 1/8X</math></td> </tr> </tbody> </table> <p>*W=DISTANCE BETWEEN SEALANT AREA AND LCD PANEL EDGE X = LCD SIDE LENGTH t = GLASS THICKNESS</p>	a	b	c	$\leq t/2$	< VIEWING AREA	$\leq 1/8X$	$t/2 > , \leq 2t$	$\leq W/2$	$\leq 1/8X$
		a	b	c							
		$\leq t/2$	< VIEWING AREA	$\leq 1/8X$							
		$t/2 > , \leq 2t$	$\leq W/2$	$\leq 1/8X$							
<p>CORNER PART :</p>  <table border="1"> <thead> <tr> <th>a</th> <th>b</th> <th>c</th> </tr> </thead> <tbody> <tr> <td><math>\leq t/2</math></td> <td>&lt; VIEWING AREA</td> <td><math>\leq 1/8X</math></td> </tr> <tr> <td><math>&gt; t/2 , \leq 2t</math></td> <td><math>\leq W/2</math></td> <td><math>\leq 1/8X</math></td> </tr> </tbody> </table> <p>*W=DISTANCE BETWEEN SEALANT AREA AND LCD PANEL EDGE X = LCD SIDE LENGTH t = GLASS THICKNESS</p>	a	b	c	$\leq t/2$	< VIEWING AREA	$\leq 1/8X$	$> t/2 , \leq 2t$	$\leq W/2$	$\leq 1/8X$		
a	b	c									
$\leq t/2$	< VIEWING AREA	$\leq 1/8X$									
$> t/2 , \leq 2t$	$\leq W/2$	$\leq 1/8X$									
<p>CHIP ON ELECTRODE PAD</p>  <table border="1"> <thead> <tr> <th>a</th> <th>b</th> <th>c</th> </tr> </thead> <tbody> <tr> <td><math>\leq t</math></td> <td><math>\leq 0.5\text{mm}</math></td> <td><math>\leq 1/8X</math></td> </tr> </tbody> </table> <p>* X=LCD SIDE WIDTH t=GLASS THICKNESS</p>	a	b	c	$\leq t$	$\leq 0.5\text{mm}$	$\leq 1/8X$					
a	b	c									
$\leq t$	$\leq 0.5\text{mm}$	$\leq 1/8X$									
 <table border="1"> <thead> <tr> <th>a</th> <th>b</th> <th>c</th> </tr> </thead> <tbody> <tr> <td><math>\leq t</math></td> <td><math>\leq 1/8X</math></td> <td><math>\leq L</math></td> </tr> </tbody> </table> <p>*X=LCD SIDE WIDTH t = GLASS THICKNESS L=ELECTRODE PAD LENGTH</p> <p>①IF GLASS CHIPPING THE ITO TERMINAL, OVER 2/3 OF THE ITO MUST REMAIN AND BE, INSPECTED ACCORDING TO ELECTRODE TERMINAL SPECIFICATIONS</p> <p>②IF THE PRODUCT WILL BE HEAT SEALED BY THE CUSTOMER, THE ALIGNMENT MARK MUST NOT BE DAMAGED</p>	a	b	c	$\leq t$	$\leq 1/8X$	$\leq L$					
a	b	c									
$\leq t$	$\leq 1/8X$	$\leq L$									

13.4 RELIABILITY TEST

13.4.1 STANDARD SPECIFICATIONS FOR RELIABILITY OF LCD MODULE

NO	ITEM	DESCRIPTION
1	HIGH TEMPERATURE OPERATION	THE SAMPLE SHOULD BE ALLOWED TO STAND AT +70°C FOR 240 HRS
2	LOW TEMPERATURE OPERATION	THE SAMPLE SHOULD BE ALLOWED TO STAND AT -20°C FOR 240 HRS
3	HIGH TEMPERATURE STORAGE	THE SAMPLE SHOULD BE ALLOWED TO STAND AT +80°C FOR 240 HRS
4	LOW TEMPERATURE STORAGE	THE SAMPLE SHOULD BE ALLOWED TO STAND AT -30°C FOR 240 HRS
5	HIGH TEMP / HUMIDITY TEST STORAGE	THE SAMPLE SHOULD BE ALLOWED TO STAND AT 60°C, 90% RH 240 HRS
6	THERMAL SHOCK (NOT OPERATED)	<p>THE SAMPLE SHOULD BE ALLOWED TO STAND THE FOLLOWING 10 CYCLES OF OPERATION:</p>
7	ESD (ELECTROSTATIC DISCHARGE) (NOT OPERATED)	<p>AIR DISCHARGE ± 12KV CONTACT DISCHARGE ± 8KV (ACCORDING TO IEC-61000-4-2)</p>

NOTE (1) : THE TEST SAMPLES HAVE RECOVERY TIME FOR 2 HOURS AT ROOM TEMPERATURE BEFORE THE FUNCTION CHECK. IN THE STANDARD CONDITIONS, THERE IS NO DISPLAY FUNCTION NG ISSUE OCCURRED.

### 13.5 TESTING CONDITIONS AND INSPECTION CRITERIA

FOR THE FINAL TEST THE TESTING SAMPLE MUST BE STORED AT ROOM TEMPERATURE FOR 24 HOURS, AFTER THE TESTS LISTED IN TABLE 13.5, STANDARD SPECIFICATIONS FOR RELIABILITY HAVE BEEN EXECUTED IN ORDER TO ENSURE STABILITY.

NO	ITEM	TEST MODEL	INSPECTION CRITERIA
1	CURRENT CONSUMPTION	REFER TO SPECIFICATION	THE CURRENT CONSUMPTION SHOULD CONFORM TO THE PRODUCT SPECIFICATION.
2	CONTRAST	REFER TO SPECIFICATION	AFTER THE TESTS HAVE BEEN EXECUTED, THE CONTRAST MUST BE LARGER THAN HALF OF ITS INITIAL VALUE PRIOR TO THE TESTS.
3	APPEARANCE	VISUAL INSPECTION	DEFECT FREE

### 13.6 OPERATION

- 13.6.1 DO NOT CONNECT OR DISCONNECT MODULES TO OR FROM THE MAIN SYSTEM WHILE POWER IS BEING SUPPLIED .
- 13.6.2 USE THE MODULE WITHIN SPECIFIED TEMPERATURE ; LOWER TEMPERATURE CAUSES THE RETARDATION OF BLINKING SPEED OF THE DISPLAY ; HIGHER TEMPERATURE MAKES OVERALL DISPLAY DISCOLOR. WHEN THE TEMPERATURE RETURNS TO NORMALITY, THE DISPLAY WILL OPERATE NORMALLY .
- 13.6.3 ADJUST THE LC DRIVING VOLTAGE TO OBTAIN THE OPTIMUM CONTRAST.
- 13.6.4 POWER ON SEQUENCE INPUT SIGNALS SHOULD NOT BE SUPPLIED TO LCD MODULE BEFORE POWER SUPPLY VOLTAGE IS APPLIED AND REACHES THE SPECIFIED VALUE .  
IF ABOVE SEQUENCE IS NOT FOLLOWED , CMOS LSIS OF LCD MODULES MAY BE DAMAGED DUE TO LATCH - UP PROBLEM .
- 13.6.5 NOT ALLOWED TO INFLICT ANY EXTERNAL STRESS AND TO CAUSE ANY MECHANICAL INTERFERENCE ON THE BENDING AREA OF FPC DURING THE TAIL BENDING BACKWARDS!  
DO NOT STRESS FPC AND IC ON THE MODULE!

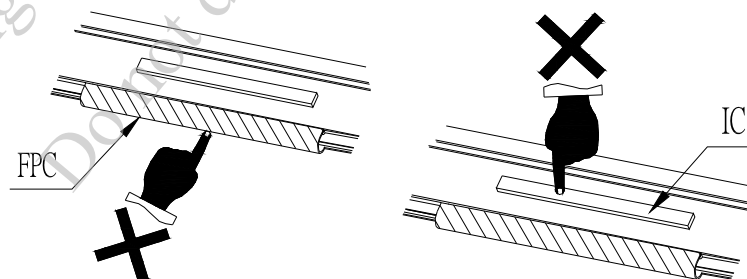

### 13.7 NOTICE

- 13.7.1 USE A GROUNDED SOLDERING IRON WHEN SOLDERING CONNECTOR I/O TERMINALS . FOR SOLDERING OR REPAIRING, TAKE PRECAUTION AGAINST THE TEMPERATURE OF THE SOLDERING IRON AND THE SOLDERING TIME TO PREVENT PEELING OFF THE THROUGH-HOLE-PAD .
- 13.7.2 DO NOT DISASSEMBLE . EDT SHALL NOT BE HELD RESPONSIBLE IF THE MODULE IS DISASSEMBLED AND UPON THE REASSEMBLY THE MODULE FAILED .
- 13.7.3 DO NOT CHARGE STATIC ELECTRICITY , AS THE CIRCUIT OF THIS MODULE CONTAINS CMOS LSIS. A WORKMAN'S BODY SHOULD ALWAYS BE STATIC-PROTECTED BY USE OF AN ESD STRAP. WORKING CLOTHES FOR SUCH PERSONNEL SHOULD BE OF STATIC-PROTECTED MATERIAL .
- 13.7.4 ALWAYS GROUND THE ELECTRICALLY-POWERED DRIVER BEFORE USING IT TO INSTALL THE LCD MODULE. WHILE CLEANING THE WORK STATION BY VACUUM CLEANER, DO NOT BRING THE SUCKING MOUTH NEAR THE MODULE ; STATIC ELECTRICITY OF THE ELECTRICALLY-POWERED DRIVER OR THE VACUUM CLEANER MAY DESTROY THE MODULE .
- 13.7.5 DON'T GIVE EXTERNAL SHOCK.
- 13.7.6 DON'T APPLY EXCESSIVE FORCE ON THE SURFACE.
- 13.7.7 LIQUID IN LCD IS HAZARDOUS SUBSTANCE. MUST NOT LICK AND SWALLOW.  
WHEN THE LIQUID IS ATTACH TO YOUR, SKIN, CLOTH ETC.  
WASH IT OUT THOROUGHLY AND IMMEDIATELY.
- 13.7.8 DON'T OPERATE IT ABOVE THE ABSOLUTE MAXIMUM RATING.
- 13.7.9 STORAGE IN A CLEAN ENVIRONMENT, FREE FROM DUST, ACTIVE GAS, AND SOLVENT.
- 13.7.10 STORE WITHOUT ANY PHYSICAL LOAD.
- 13.7.11 REWIRING: NO MORE THAN 3 TIMES.