

## PWM Fan Motor Driver with Slope Control and Low Duty Startup

### DESCRIPTION

EUM6804 is a fan motor driver for brushless DC fan motor. It integrates three types speed control modes, low duty startup function, soft switched output, lock protection, Hall bias, FG output, shutdown mode, quick restart and TSD. With these modes and functions, EUM6804 can not only be applied to DC fans which require different speed curves, but also be applied to NB and other portable equipments which require silence and low power dissipation.

The three types speed control modes are PWM control mode, VCC control mode with slope adjustable, normal VCC control mode. Low duty startup function makes it possible for DC fan to start and restart under a very low PWM duty cycle. Soft switched output drives DC fan in low noise and low vibration. If a DC fan is stalled by the external force or obstacles, overdrive current may incur coil overheat and burning. To prevent motor from overheating, the lock protection circuit shuts down the internal power devices for a few seconds after the motor lock is detected. Then the auto restart circuit resumes to power up the internal power devices. EUM6804 has built in Hall IC bias output, motor rotation speed feedback (FG). With its shutdown mode and quick restart, EUM6804 consume little power dissipation during shutdown time and can be started at once regardless of lock detection time.

### FEATURES

- Single-Phase Full-Wave Driver System
- Three Speed Control Mode  
PWM Control Mode  
VCC Control Mode with Slope Adjustable  
Normal VCC Control Mode
- Low Duty Startup  
SD = H: Enable Low Duty Startup  
SD = L: Disable Low Duty Startup
- Soft Switched Drive for Silent Application
- Lock Detection and Automatic Restart
- Shutdown Mode and Quick Restart  
Low Standby Current (PWM = L)
- FG Output
- Hall Bias Output
- Thermal Shutdown Protection
- Available in UDFN-10 Package
- RoHS Compliant and 100% Lead (Pb)-Free Halogen-Free

### APPLICATIONS

- NB Cooling Fan
- Silent Fan Motor

### Application Circuit

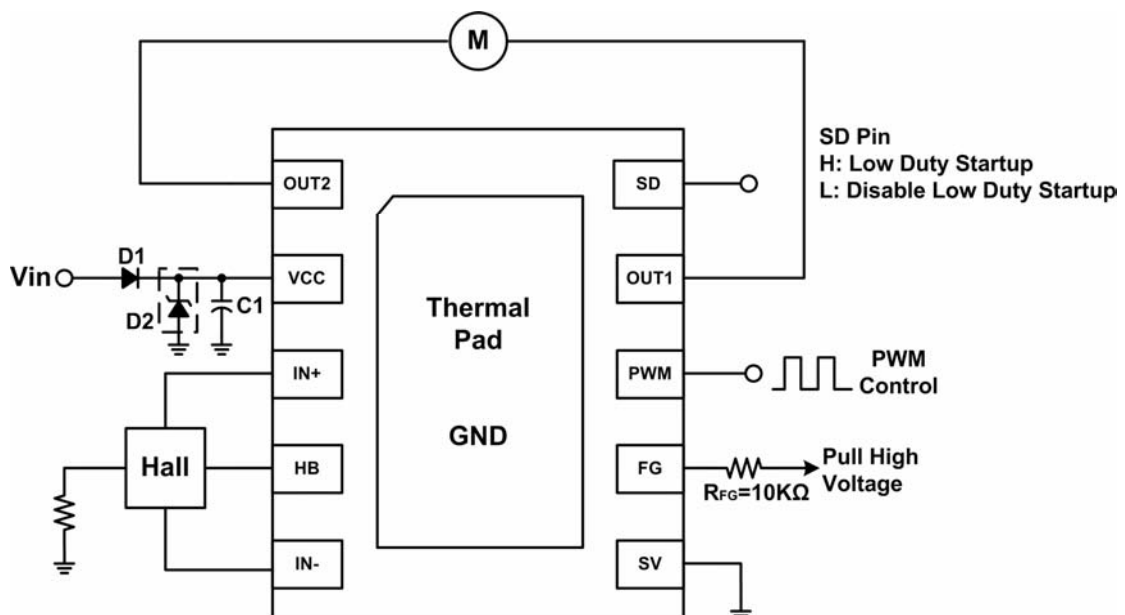
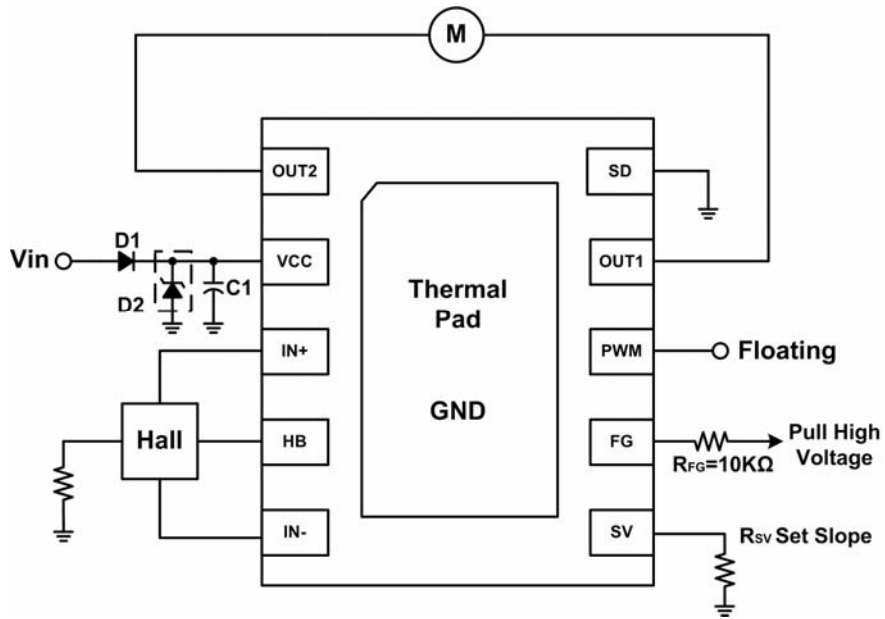
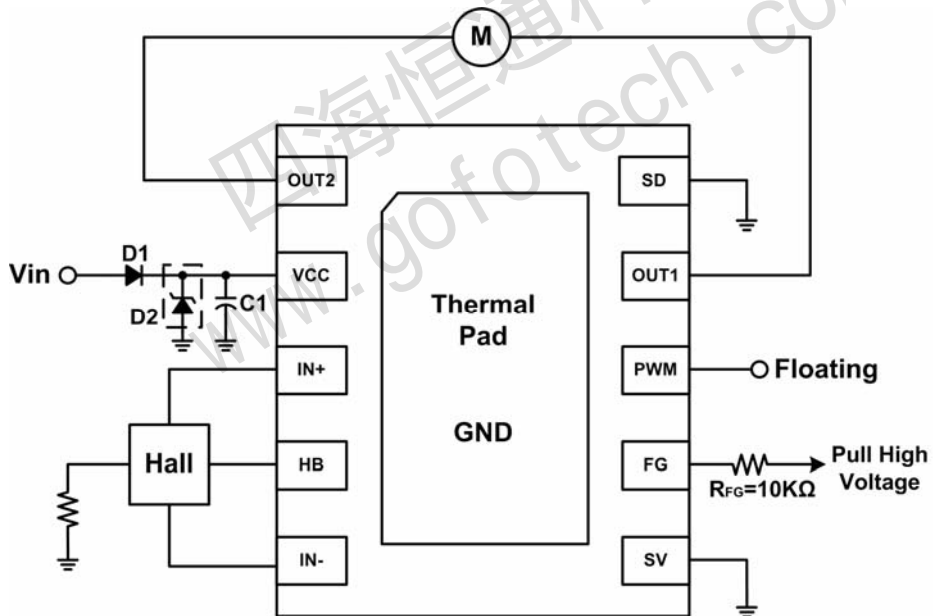

Figure 1. PWM Control Mode

**Application Circuit (continued)**



**Figure 2. VCC Control Mode with Slope Adjustable**



**Figure 3. Normal VCC Control Mode**

**Pin Configurations**

Package Type	Pin Configurations
UDFN-10	<p>(TOP VIEW)</p> <p>OUT2 1 10 SD  VCC 2 9 OUT1  IN+ 3 8 PWM  HB 4 7 FG  IN- 5 6 SV</p> <p>Thermal Pad (GND)</p>

**Pin Description**

PIN	UDFN-10	DESCRIPTION
OUT2	1	Power device output terminal 2. Connect OUT2 to one side of the motor.
VCC	2	Power supply.
IN+	3	Hall sensor positive input.
HB	4	Hall sensor bias output.
IN-	5	Hall sensor negative input.
SV	6	Speed slope control terminal. Connect a resistor between SV and GND. To disable slope control, please short SV to GND.
FG	7	Rotation speed feedback output.
PWM	8	PWM control signal input.
OUT1	9	Power device output terminal 1. Connect OUT1 to the other side of the motor.
SD	10	Low duty startup selection. Set High to enable; short to GND to disable.
GND	Thermal Pad	IC ground.

**Power Dissipation**

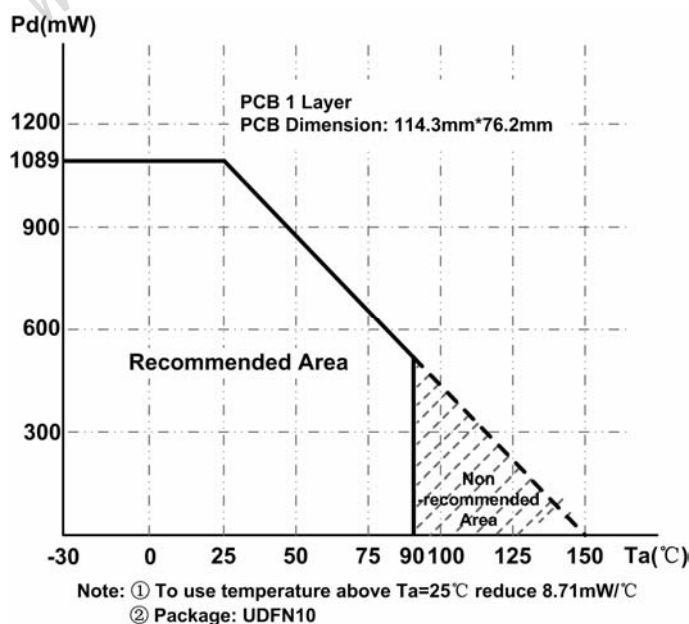

**Figure 4. Power Dissipation Curve**

**Ordering Information**

Order Number	Package Type	Marking	Operating Temperature Range
EUM6804SIR1	UDFN-10	XXXXX M6804	-30°C to 90°C

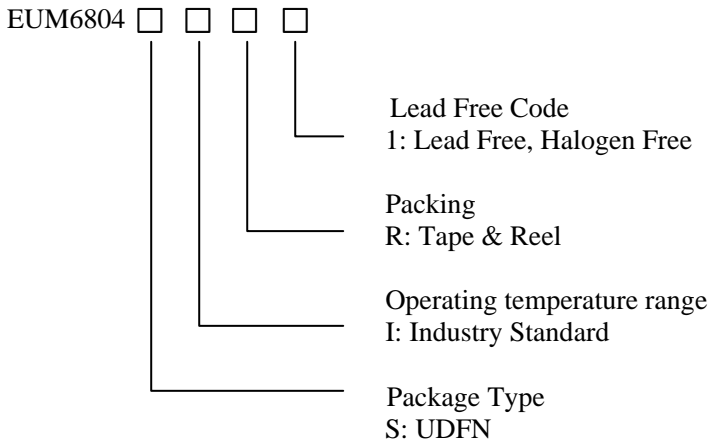

**Block Diagram**

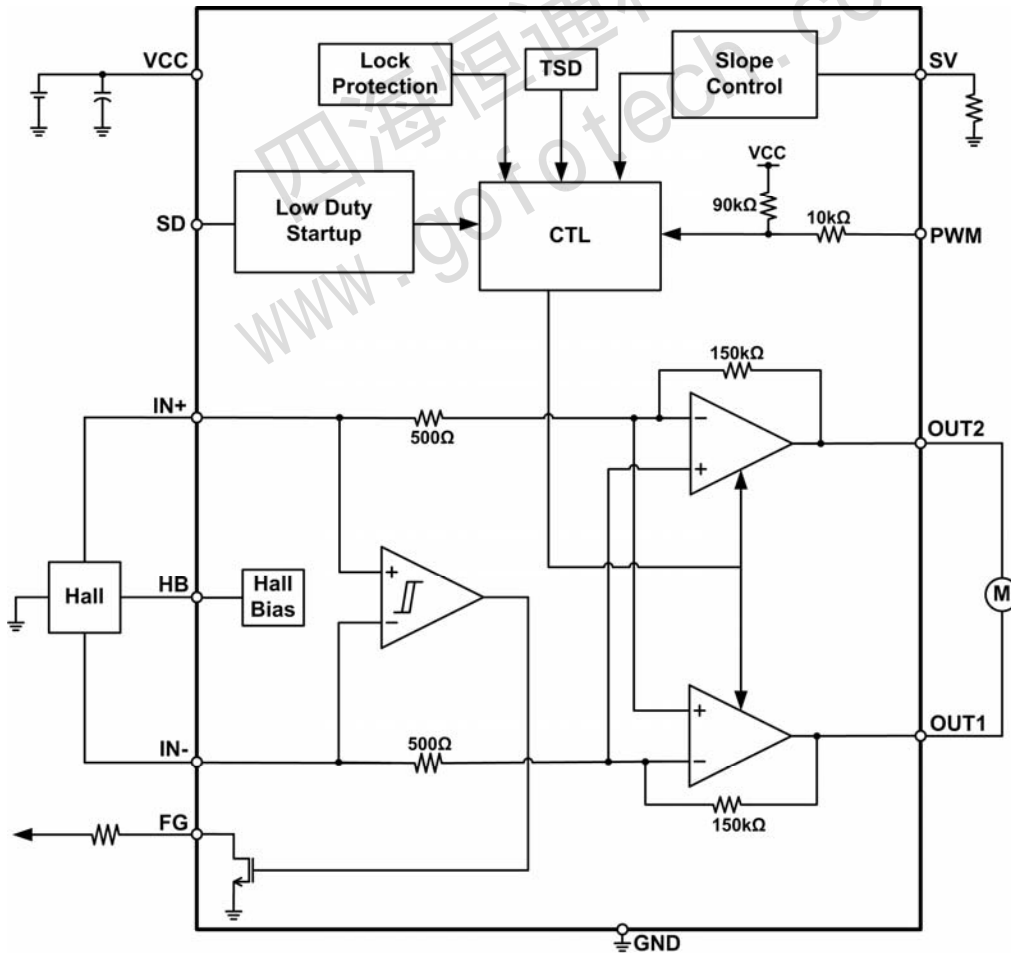

Figure 5.

**Absolute Maximum Ratings (1)**

- VCC ----- -0.3V to 7V
- OUT1, OUT2 ----- -0.3V to 7V
- IN+, IN-, HB, SV, PWM, SD ----- -0.3V to 7V
- Iomax ----- 1000mA
- VFG ----- -0.3V to 7V
- IFG, IHB ----- 10mA
- Maximum Junction Temperature ----- +150°C
- Lead Temperature (Soldering, 10sec.) ----- +300°C
- Package Thermal Resistance  $\theta_{JA}$  (UDFN-10) ----- 114.81°C/W (2)
- Power Dissipation PD @  $T_A=+25^\circ\text{C}$  (UDFN-10) ----- 1089 mW (2)
- Storage Temperature ----- -55°C to +150°C
- ESD Ratings
- Human Body Mode ----- 2K
- Thermal Shut Down ----- 160°C
- Thermal Shut Down Hysteresis ----- 30°C

**Recommended Operating Conditions (3)**

- Supply Voltage VCC ----- 1.8V to 6V
- Hall Input Voltage Range IN+, IN- ----- 0.3V to Vcc-1.1V
- Operating Temperature Range ----- -30°C to +90°C

Note (1): Stress beyond those listed under “Absolute Maximum Ratings” may damage the device.

Note (2): PCB: 1 layer, dimension 114.3mm\*76.2mm.

Note (3): The device is not guaranteed to function outside the recommended operating conditions.

**Electrical Characteristics**

Specifications in standard type face are for  $T_A=+25^\circ\text{C}$ . VCC=5.0V unless otherwise specified.

Symbol	Parameter	Conditions	EUM6804			Unit
			Min.	Typ.	Max.	
ICC1	Supply Current	Rotation Mode	-	1.1	1.6	mA
ICC2		Lock Protection Mode	-	1.1	1.6	
ICC3		Shutdown Mode	-	50	70	
<b>Hall Bias</b>						
VHB	HB Output Voltage	IHB=5mA	1.0	1.2	1.4	V
<b>Hall Input Signal</b>						
VHOFS	Input Offset Voltage		-	-	$\pm 6$	mV
VHYS	Input Hysteresis Voltage		-	$\pm 10$	$\pm 20$	mV
<b>Output</b>						
VO	Output Voltage	$I_o=250\text{mA}$ Upper and Lower Total	-	0.14	0.20	V
Gio	Input-Output Gain		48	49	50	dB
<b>FG Signal Output</b>						
VFGL	FG Low Voltage	IFG=5mA	-	-	0.1	V
IFGL	FG Leakage Current	VFG=7V	-	-	1	$\mu\text{A}$
<b>Lock Protection</b>						
TON	Lock Detection On Time		0.4	0.5	0.66	Sec
TOFF	Lock Detection Off Time		4	5	6.6	Sec
<b>PWM Input</b>						
VPWMH	PWM Input H Level		$0.5 \times VCC$	-	$VCC+0.5$	V
VPWML	PWM Input L Level		0	-	$0.2 \times VCC$	V
FPWM	PWM Input Frequency		2	-	50	kHz
TQ	Quick Startup Time		100	130	165	mS
<b>Low Duty Enable Input</b>						
VSDH	SD Input H Level		$0.5 \times VCC$	-	$VCC+0.5$	V
VSDL	SD Input L Level		0	-	$0.2 \times VCC$	V
<b>VCC Slope Control Output</b>						
ISV	SV Output Current	VCC=3V, SV=0V	-	18	-	$\mu\text{A}$

**APPLICATION NOTES**

**PWM Control Mode**

This IC is able to control motor rotation speed by PWM control mode. If PWM input is high, IC will charge the motor coil current. On the contrary, if PWM input is low, IC will re-circulate the motor coil current. So, PWM input signal duty cycle control the motor speed. See Fig6 and Fig7 T2 to T3.

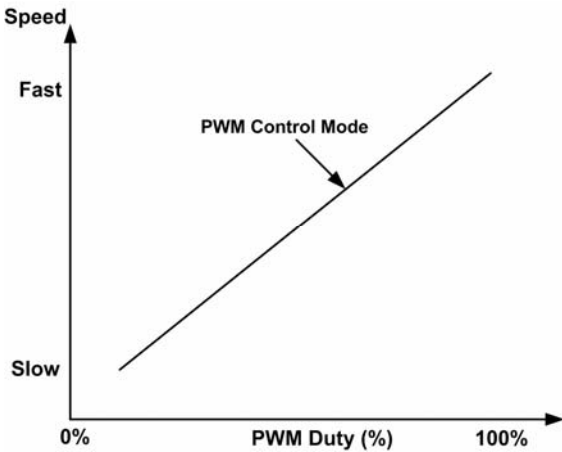

**Figure 6. PWM Control Mode**

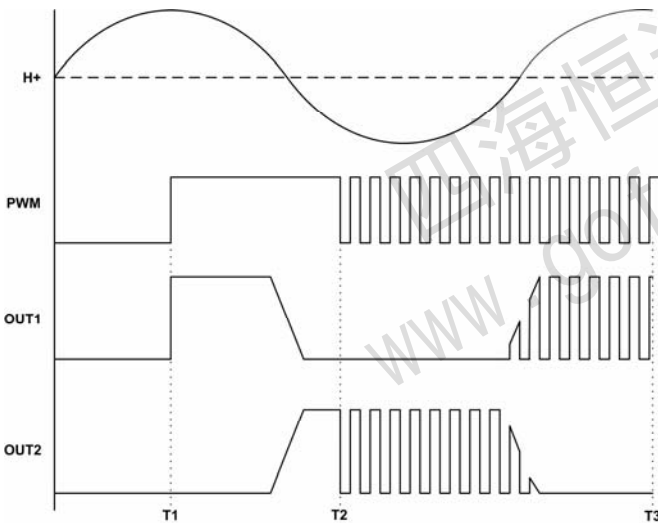

**Figure 7. PWM Control Timing Chart**

**VCC Control Mode**

This IC is able to control motor rotation speed by VCC control mode. When use this mode, please set PWM to high voltage such as VCC, or floating PWM. The higher the VCC voltage is, the faster the motor speed is. See output waves in Fig7 T1 to T2.

**VCC Control Mode with Slope Adjustable**

This IC is able to control motor rotation speed by VCC control mode with slope adjustable. When use this mode, please set PWM to high voltage such as VCC, or floating PWM. Please connect a resistor between SV and GND. The bigger the resistor is, the bigger the speed curve slope is. See Fig8.

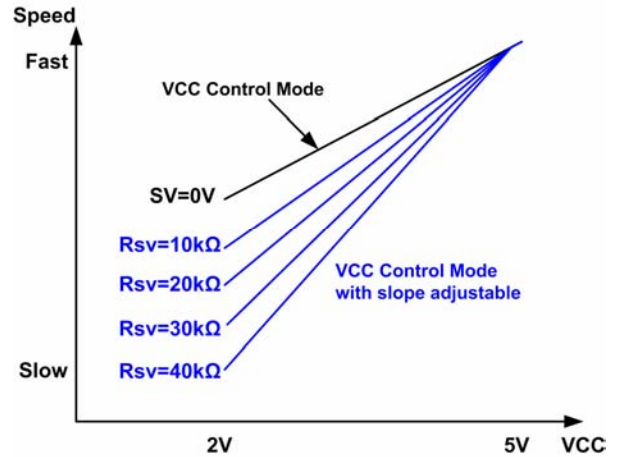

**Figure 8. VCC Control Mode with Slope Adjustable**

**Low Dusty Startup Function**

Because of static friction, some fan motors will not start or restart under low PWM duty cycle. The low duty startup function can help these fans to complete start and restart. To use this function, please set SD to VCC. Then, the startup output duty cycle will be fixed at 50% no matter what PWM duty cycle is (except PWM = 0% motor enter shut down mode). After startup complete, the external PWM input duty cycle will take over control. To disable this function, please short SD to GND.

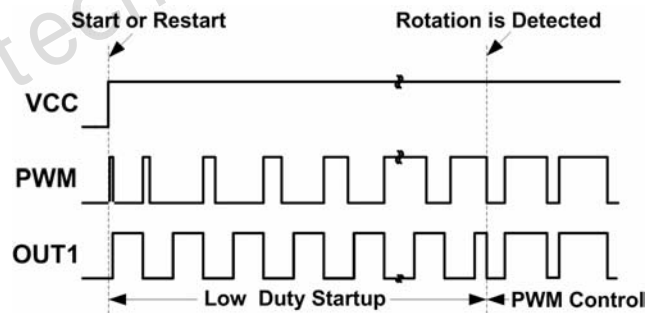
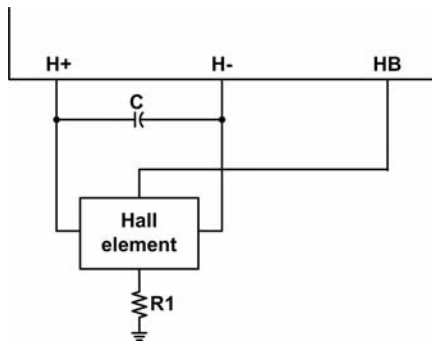

**Figure 9. Low Duty Startup Function**

Control Mode	Start or Restart Out Duty	Rotate Out Duty (after start or restart)
SD = GND PWM input SV = GND	OUT Duty = PWM Duty	OUT Duty = PWM Duty
SD = VCC PWM input SV = GND	OUT Duty = 50%	OUT Duty = PWM Duty
SD = GND SV connect Resistor	OUT Duty = 100%	OUT Duty controlled by VCC voltage and Rsv.
SD = VCC SV connect Resistor	OUT Duty = 50%	OUT Duty controlled by VCC voltage and Rsv.



**Hall Sensor Connection**



**Figure 10. Hall sensor Inputs**

**Hall Signal Input Terminals (H+、H-)**

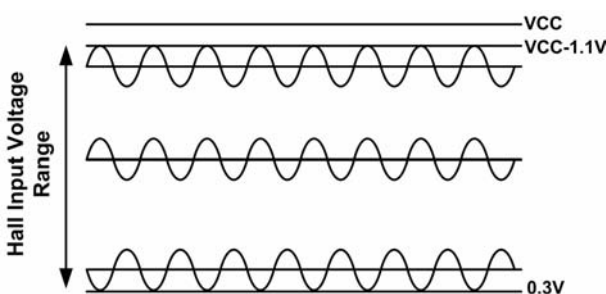
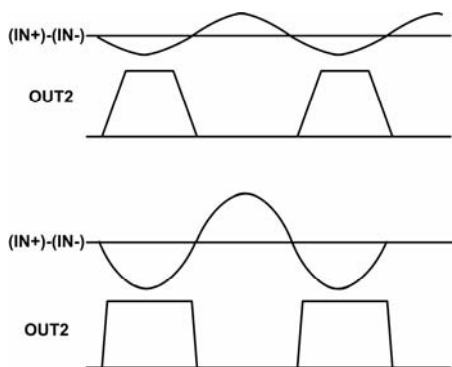

**Figure 11. Hall sensor Inputs**

Set Hall sensor input signal range 0.3V to VCC-1.1V by adjusting the Hall input level setting resistor R1. In the case of long board wiring pattern from hall element to hall signal input terminal, connect a capacitor between IN+ and IN- to avoid noise. The amplitude of Hall input signal is recommended to be 60mV or higher due to the Hall input Pin  $\pm 10\text{mV}$ (TYP.) hysteresis. The Hall bias is 1.2V(TYP).

**Soft Switched Output**

The output signal of this IC is the amplified hall input signal, therefore, the output signal depends on hall input signal. When the amplitude of hall signal is small, the output signal becomes gentle. Oppositely, the amplitude is big, the output signal becomes steep. The hall-input/output gain is about 300 times (TYP). So, please input the suitable signal to make an adequate amplitude of the output signal.



**Figure 12.**

**Shutdown Mode and Quick Startup**

If setting PWM to low level more than 130mS (TYP), IC will enter shutdown mode. In shutdown mode, the output stage, FG and Hall Bias are shut down. Thus, the supply current is only 50 $\mu\text{A}$  (TPY). Shutdown mode will disable lock protection function. This means if shutdown mode is released, fan motor will restart immediately (that is quick startup).

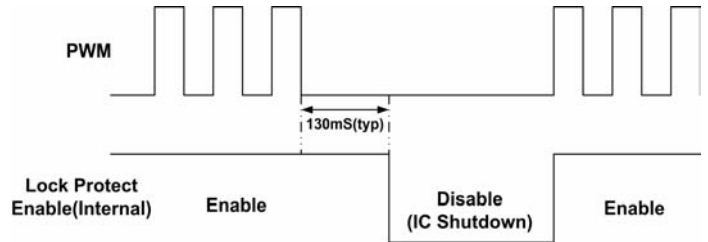

**Figure 13.**

**Lock Detection, Automatic Restart Circuit**

This IC detect the rotation of the motor by hall signal, and set lock detection ON time (Ton) and lock detection OFF time (Toff) by the internal counter. These time (Ton, Toff) are showed below.

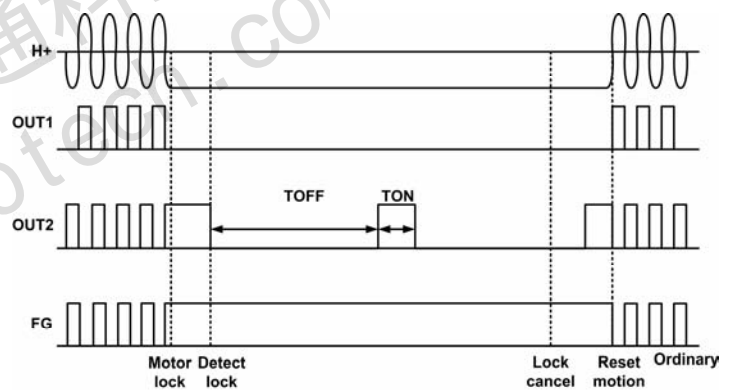

**Figure 14.**

**Thermal Shutdown (TSD)**

This IC has built-in TSD. TSD has the temperature hysteresis.

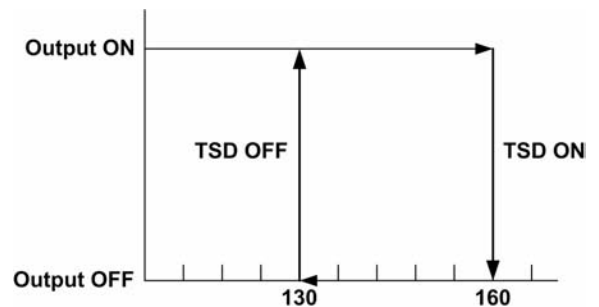

**Figure 15.**

**VCC and PVCC Bypass**

In UDFN-10, Connect a ceramic capacitor 1 $\mu$ F or more between VCC and GND to absorb kick back voltage resulting from the high side re-circulation current.

**GND and PGND Line**

In UDFN-10, The GND terminal (Thermal PAD) should be the location of the lowest voltage on the chip.

**Truth Table for EUM6804**

H+	H-	PWM	OUT1	OUT2	FG	
H	L	H	H	L	L	Normal Operation
L	H		L	H	Off	
H	L	L	L	L	L	
L	H		L	L	Off	
H	L	-	L	L	L	Lock Protection
L	H		L	L	Off	
-	-	L	L	L	Off	Shutdown

**Test Waveform on DC Fan**

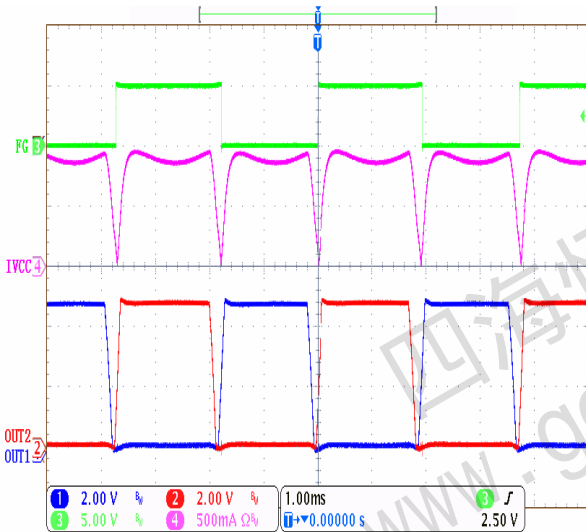

Figure 16. Test Waveform on Fan PWM=100%

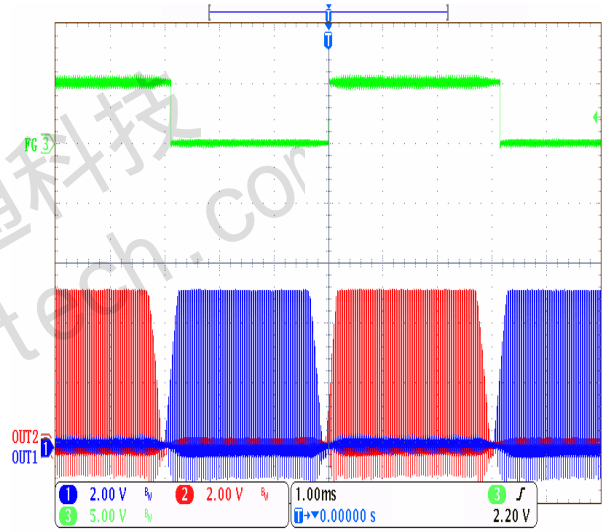

Figure 17. Test Waveform on Fan PWM=50%

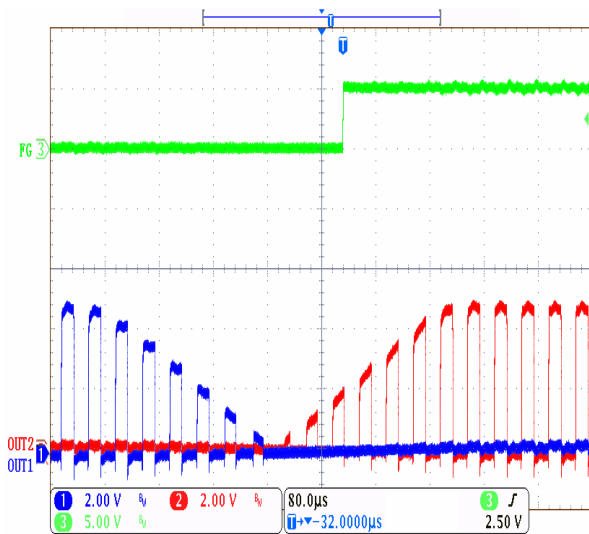

Figure 18. Test Waveform on Fan PWM=50% (Zoom in)

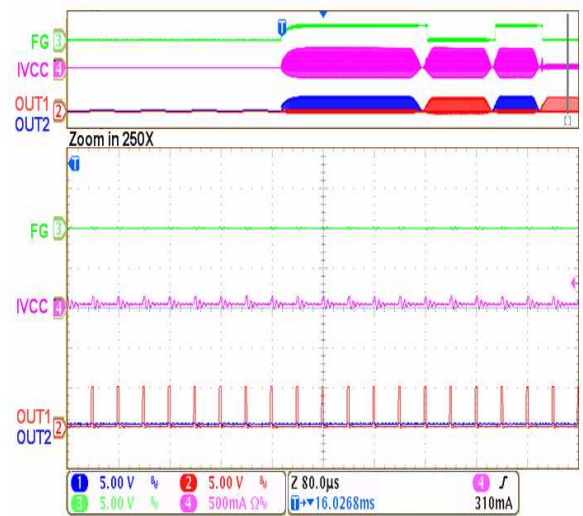
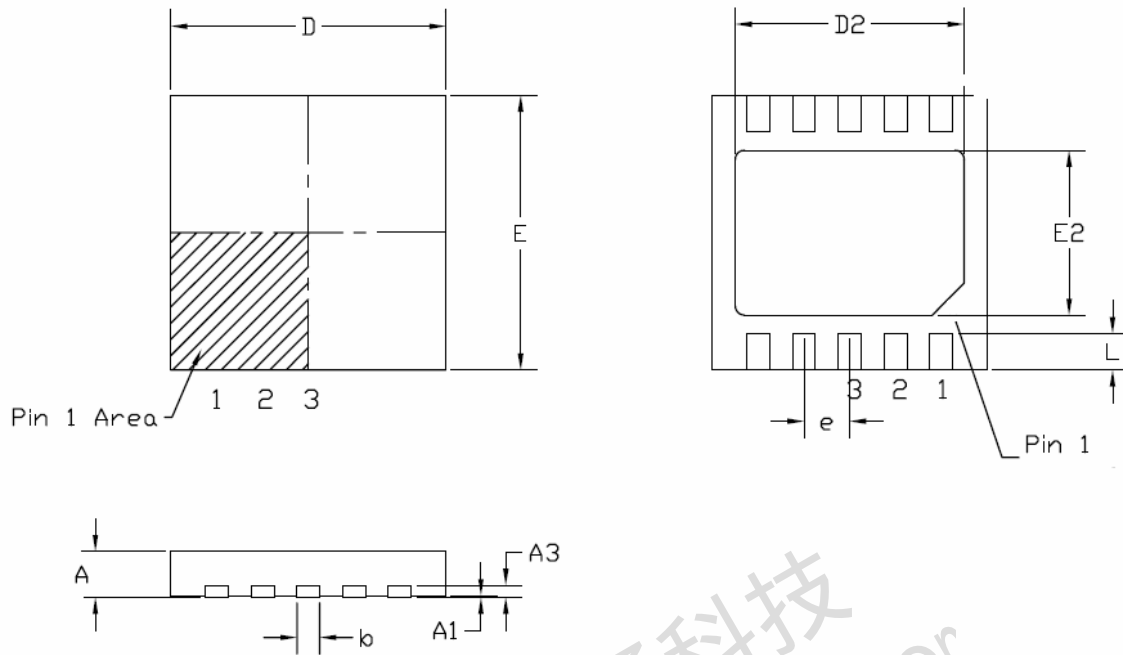

Figure 19. Test Waveform Low Duty Startup at PWM=10%



**Packaging Information**

**UDFN-10**



SYMBOLS	MILLIMETERS		INCHES	
	MIN.	MAX.	MIN.	MAX.
A	0.45	0.55	0.018	0.022
A1	0.00	0.05	0.000	0.002
A3	0.130 REF		0.006 REF	
b	0.20	0.30	0.008	0.012
D	2.90	3.10	0.115	0.123
D2	2.50 REF		0.099 REF	
E	2.90	3.10	0.115	0.123
E2	1.80 REF		0.071 REF	
e	0.50 BSC		0.020 BSC	
L	0.35	0.45	0.014	0.018