

# Single-Phase Full-Wave Motor Driver with Direct PWM Input

## DESCRIPTION

EUM6898R/S is a motor driver for single coil brushless DC motor. With its high efficient direct PWM control mode, EUM6898R/S can control the speed of brushless DC motor. It integrates minimum speed mode, stop mode, adjustable speed slope control mode, soft start mode, fan tachometer, lock protection, auto restart, TSD, OCP and noise controlled mode. Noise control mode optimizes low noise performance with a SW pin's resistor according to different requirements, and can drive the BLDC fan motor in low noise and low vibration. Minimum speed mode can set minimum motor speed by presetting RMIN voltage. Stop speed mode can set stop PWM duty by presetting STOP voltage. The adjustable speed slope control mode can set fan speed slope by presetting SL voltage. Soft start suppresses high peak start-up current, which will also provide a reliable start-up even for low rotation speed. If the motor is stalled by external force or obstacles, overdrive current may incur coil overheat. To prevent this, lock protection circuit can shut down the internal power devices for a few seconds after motor lockup. Then auto restart circuit will try to power up these devices. EUM6898R/S has FG output.

## FEATURES

- Single-phase Full-wave Driver
- Few External Components
- Built-in Input Surge Protection, No Zener Diode Need
- External Programmable Soft Start and Soft Restart Function
- Wide Input Range 3.0V~18V
- Direct PWM Fan Speed Control
- Programmable Minimum Fan Speed (EUM6898R only)
- Programmable Noise Control by an External Resistor
- Stop Mode PWM Duty Adjustable (EUM6898S only)
- Fan Speed Slope Control
- Built-in Over Current Protection Function
- Lock Protection and Auto Restart
- Built in Hall Bias
- Fan Rotation Speed Feedback FG Output
- Available in TSSOP-14 (EP) Package
- RoHS Compliant and 100% Lead (Pb)-Free Halogen-Free

## Application Circuit

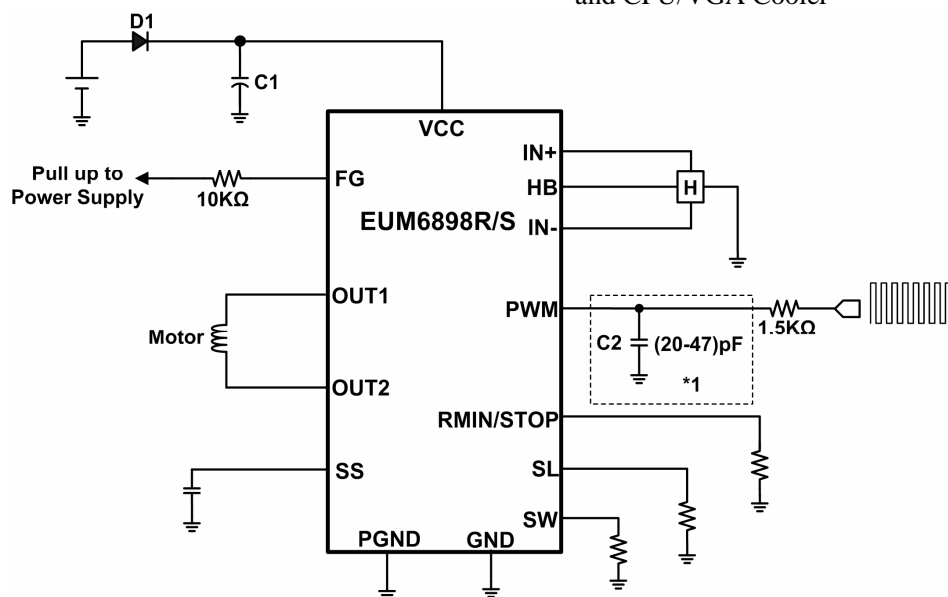

Note: \*1. The capacitor C2 can be omitted if the PWM Pin is not floating.

Figure 1. Typical Application Circuit

## Pin Configurations

Package Type	Pin Configurations	Package Type	Pin Configurations
EUM6898RX TSSOP-14 (EP)	<p>(TOP VIEW)</p> <p>PGND 1      14 GND            OUT2 2      13 OUT1            VCC 3      12 PWM            IN+ 4      11 SS            HB 5      10 SW            IN- 6      9 SL            FG 7      8 RMIN</p>	EUM6898SX TSSOP-14 (EP)	<p>(TOP VIEW)</p> <p>PGND 1      14 GND            OUT2 2      13 OUT1            VCC 3      12 PWM            IN+ 4      11 SS            HB 5      10 SW            IN- 6      9 SL            FG 7      8 STOP</p>

## Pin Description

PIN	EUM6898RX	EUM6898SX	DESCRIPTION
PGND	1	1	Power device ground
OUT2	2	2	Output terminal 2
VCC	3	3	Power supply of internal control circuitry and power devices
IN+	4	4	Hall sensor positive input
HB	5	5	Hall sensor bias output
IN-	6	6	Hall sensor negative input
FG	7	7	Rotation speed feedback output
RMIN	8	-	Motor minimum rotation speed control
STOP	-	8	Stop mode setting terminal
SL	9	9	Fan slope control setting terminal
SW	10	10	Noise control setting terminal
SS	11	11	Soft start time setting terminal
PWM	12	12	PWM signal input terminal
OUT1	13	13	Output terminal 1
GND	14	14	IC ground

**Functional Block Diagram**

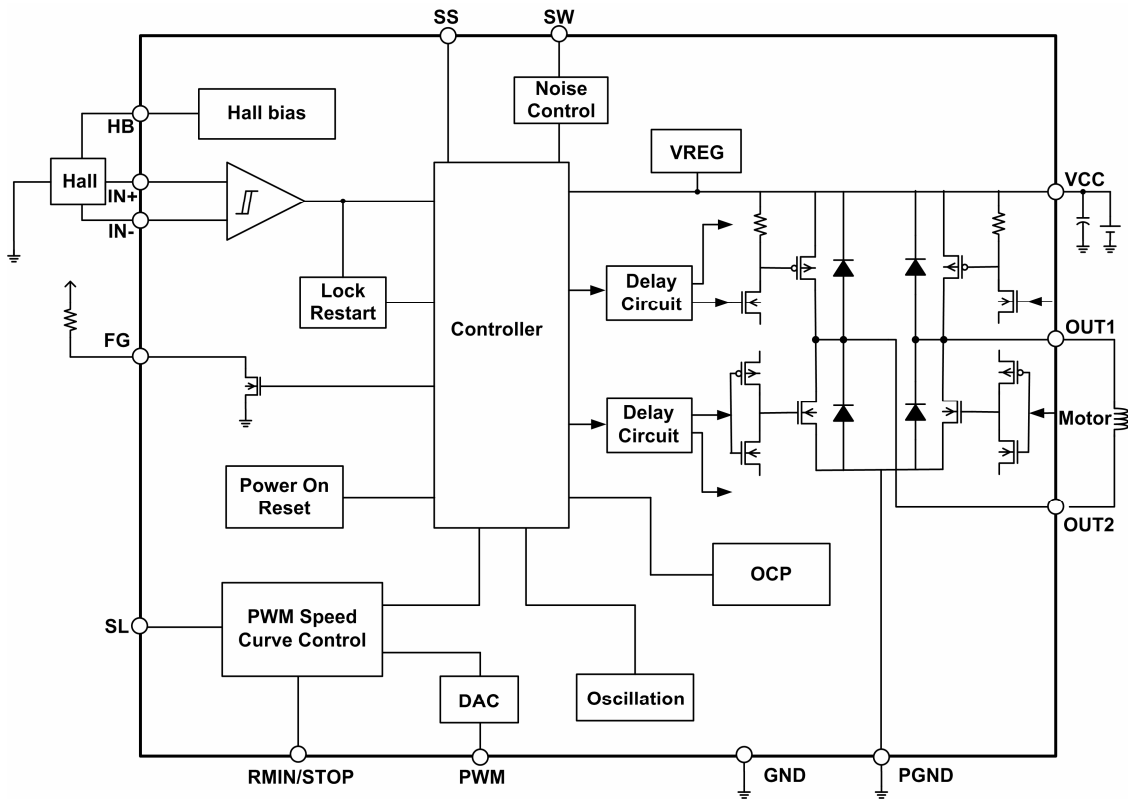

**Figure 2. Functional Block Diagram**

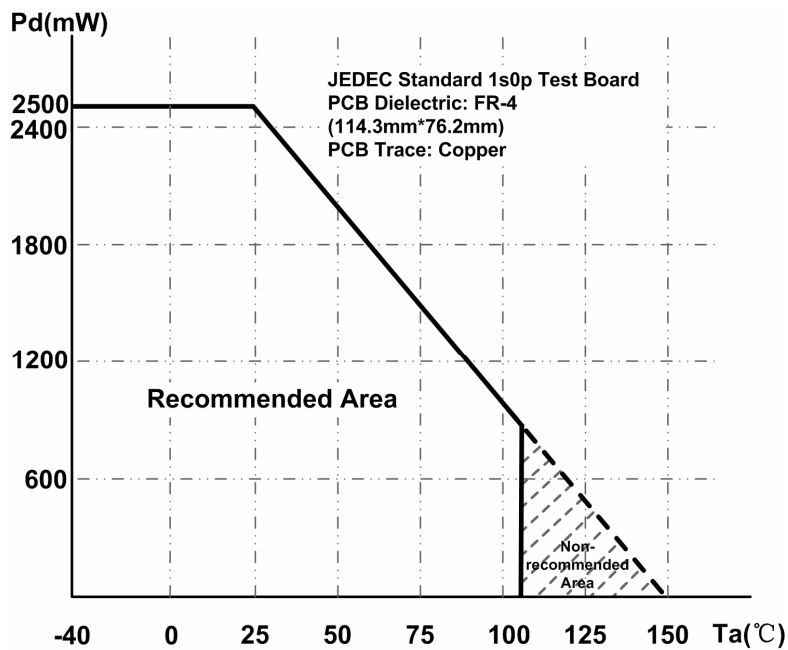

**Power Dissipation**



Note: ① To use temperature above Ta=25°C reduce 20mW/°C

**Figure 3. TSSOP-14(EP) Package**

## Ordering Information

Order Number	Package Type	Marking	Quantity per Reel	Operating Temperature Range
EUM6898RXIR1	TSSOP-14 (EP)	 xxxxx EUM6898R	2500	-40°C to +105°C
EUM6898SXIR1	TSSOP-14 (EP)	 xxxxx EUM6898S	2500	-40°C to +105°C

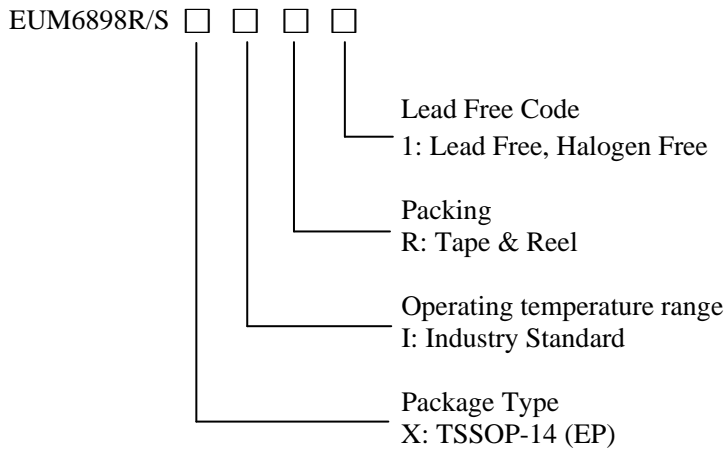

## Absolute Maximum Ratings at T<sub>A</sub>=25°C (1)

- VCC, FG (3), OUT1, OUT2 to GND----- -0.3V to 30V
- PWM to GND----- -0.3V to 6V
- RMIN, STOP, SW, SL, SS to GND----- -0.3V to 6V
- HB, IN+, IN- to GND ----- -0.3V to 6V
- PGND to GND----- -0.3V to 0.3V
- IHB, IFG, ----- 10mA
- IOUT1, IOUT2 ----- 1.35A
- Maximum Junction Temperature ----- +150°C
- Lead Temperature (Soldering, 10sec.) ----- +300°C
- Package Thermal Resistance  $\theta_{JA}$  (TSSOP-14\_EP) ----- 50°C/W
- Power Dissipation PD @ T<sub>A</sub> =+25°C (TSSOP-14\_EP) ----- 2.5W
- Storage Temperature ----- -55°C to +150°C

## Recommended Operating Conditions at T<sub>A</sub>=25°C (2)

- Supply Voltage VCC ----- 3V to 18V
- PWM Input Voltage, VPWM ----- 0V to 6V
- Threshold Input Voltage, VRMIN, VSTOP, VSS, VSW, VSL ----- 0V to 6V
- Hall Input Voltage Range IN+, IN- ----- 0.2V to 3V
- Operating Temperature Range ----- -40°C to +105°C

Note (1): Stress beyond those listed under “Absolute Maximum Ratings” may damage the device.

Note (2): The device is not guaranteed to function outside the recommended operating conditions.

Note (3): FG is open drain output, it can bear 30V voltage when FG is off.

## Electrical Characteristics

Specifications in standard type face are for T<sub>A</sub>=+25°C, VCC=12V unless otherwise specified.

Symbols	Parameters	Conditions	EUM6898R/S			Unit
			Min.	Typ.	Max.	
ICC	Operating current	VCC=12V	-	4	8	mA
<b>Hall Input and Hall Bias</b>						
VHN	Hall input sensitivity	Zero to peak (Offset & Hysteresis included)		10	20	mV
VHB	HB Output Voltage	IHB=5mA	0.97	1.12	1.27	V
VSTOP	Hysteresis of STOP mode			20	35	mV
<b>Output</b>						
VOL	Output lower side saturation	I <sub>o</sub> =200mA		0.08	0.13	V
VOH	Output upper side saturation	I <sub>o</sub> =200mA		0.12	0.18	
VOL_500	Output lower side saturation	I <sub>o</sub> =500mA		0.20	0.35	
VOH_500	Output upper side saturation	I <sub>o</sub> =500mA		0.30	0.48	
<b>Soft Start Block</b>						
ISS	SS pin discharge current	VSS = 3.6V	0.75	1.0	1.35	μA
<b>PWM Blocks</b>						
FIN	PWM input frequency		5		100	kHz
VPWML	PWM low level voltage		-0.3		0.8	V
VPWMH	PWM high level voltage		2.5		6.0	V
RIN	PWM pull-up resistor			40		kΩ

**Electrical Characteristics (continued)**

Specifications in standard type face are for  $T_A=+25^{\circ}\text{C}$ ,  $V_{CC}=12\text{V}$  unless otherwise specified.

Symbols	Parameters	Conditions	EUM6898R/S			Unit
			Min.	Typ.	Max.	
<b>PWM Blocks</b>						
FOUT	Output PWM frequency		20	28		kHz
<b>Lock Protection</b>						
Ton	Locked protection on time	SS=1.0 $\mu$ F	0.38	0.55	0.70	S
Toff	Locked protection off time	SS=1.0 $\mu$ F	3.8	5.5	7.0	S
<b>FG Signal Output</b>						
VFG	FG pin low voltage	IFG = 5mA		0.22	0.32	V
IFGL	FG pin leak current	VFG = 16V			1	$\mu$ A
<b>SW Output</b>						
VSW	SW pin output voltage	RSW=10k $\Omega$	2.45	2.7	2.95	V
<b>SL Output Current</b>						
ISL	SL output current	RSW=10k $\Omega$	120	135	150	$\mu$ A
<b>RMIN &amp; STOP Output Current</b>						
IRMIN	RMIN & STOP output current	RSW=10k $\Omega$	120	135	150	$\mu$ A

## Application Notes

### Hall Sensor Connection

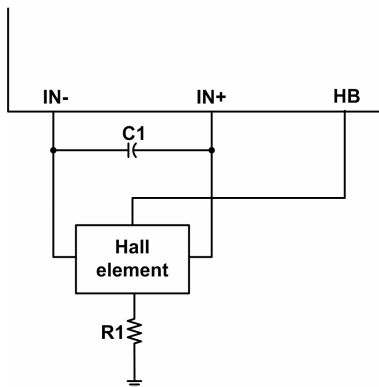

Figure 4. Hall Sensor Inputs

### Hall signal input terminals (IN+ · IN-)

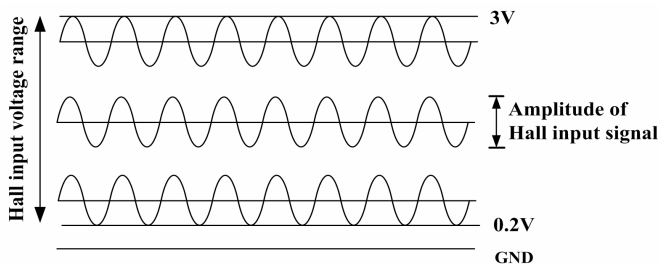

Figure 5. Hall Sensor Input Voltage Range

Set Hall sensor input signal range 0.2V to 3V by adjusting the Hall input level setting resistor R1. In the case of long board wiring pattern from hall element to hall signal input terminal, connect a capacitor between IN+ and IN- to avoid noise. The amplitude of Hall input signal is recommended to be 60mV or higher due to the Hall input amplifier 20mV hysteresis. The Hall bias is 1.2V.

### VCC Bypass Capacitor

Connect a ceramic capacitor 1.0μF or more between VCC and GND to absorb kick back voltage resulting from the high side re-circulation current.

### GND and PGND line

GND is connected to internal analog control circuits, and PGND is connected to power devices. Connect GND to PGND at only one place on the PCB board.

### Output PWM Frequency

The Output PWM frequency is settable by internal value of capacitor. Typical frequency value is 28 kHz.

### Soft Start Time

Connect a capacitor between SS and GND to set soft start time. EUM6898R/S drives a motor from slow speed to fast speed during soft start time which is set by the external capacitor between SS and GND. Please floating SS pin, if soft start function is not used. If motor start current is too big, please increase capacitor between SS and GND to make start time longer and start current smaller. If motor start current is too small to run, please decrease capacitor between SS and GND to make start time shorter and start current bigger.

### Minimum Speed Settable

The minimum speed of motor is set by input voltage of RMIN. The different voltage of RMIN can adjust the minimum fan speed. The lower RMIN is, the higher the minum output duty is. The relation is shown as the Figure 6 below ( $V_{RMIN1} > V_{RMIN2} > V_{RMIN3}$ ).

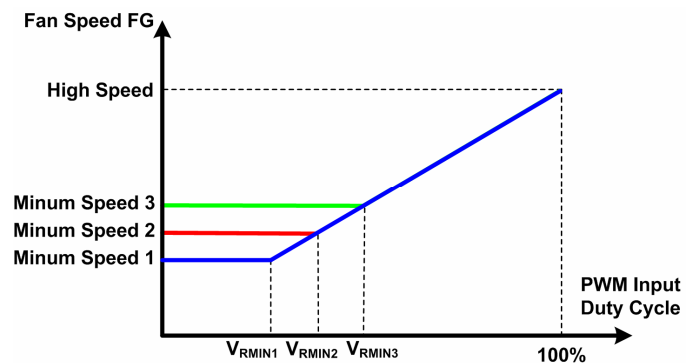

Figure 6. The Minimum Speed Control Curve

### Stop Speed Settable

When the IC using as stop mode control. The stop duty can be adjusted by the voltage of the STOP pin. The lower STOP is, the higher the output stop duty is. The relation is shown as the Figure 7 below ( $V_{STOP1} > V_{STOP2} > V_{STOP3}$ ).

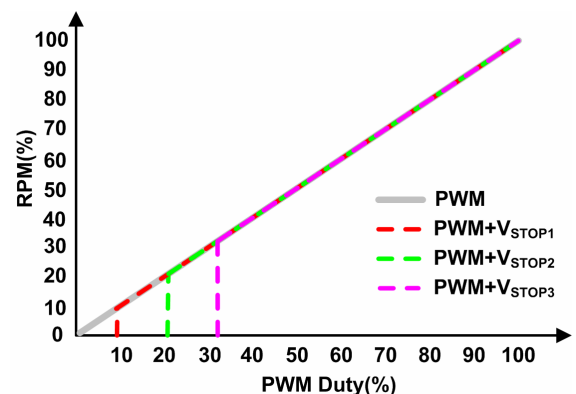

Figure 7. The Stop Speed Control Curve

## Speed Slope Settable

When the IC using as speed slope control. The speed slope is setting by SL pin, and the output duty can be adjusted by the SL pin voltage. The relation is shown as the Figure 8 below ( $V_{SL1} > V_{SL2} > V_{SL3}$ ).

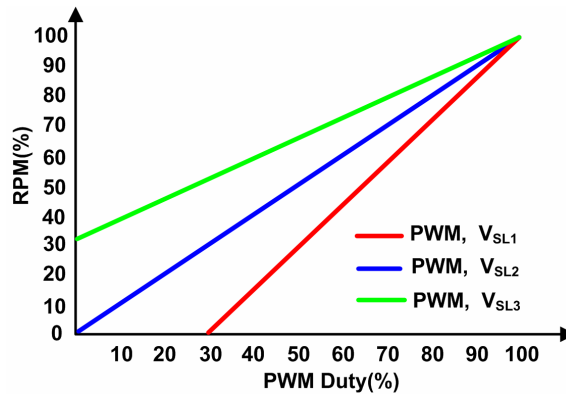

Figure 8. The Speed Slope Control Curve

## Lock Protection and Auto Restart

When the motor is locked, the EUM6898R/S output will be disabled by the lock protection function. After a few seconds, the auto restart circuit will restart the motor. If the motor lockup persists, the lock protection will keep EUM6898R/S output off until the lock removes. See Figure 9.

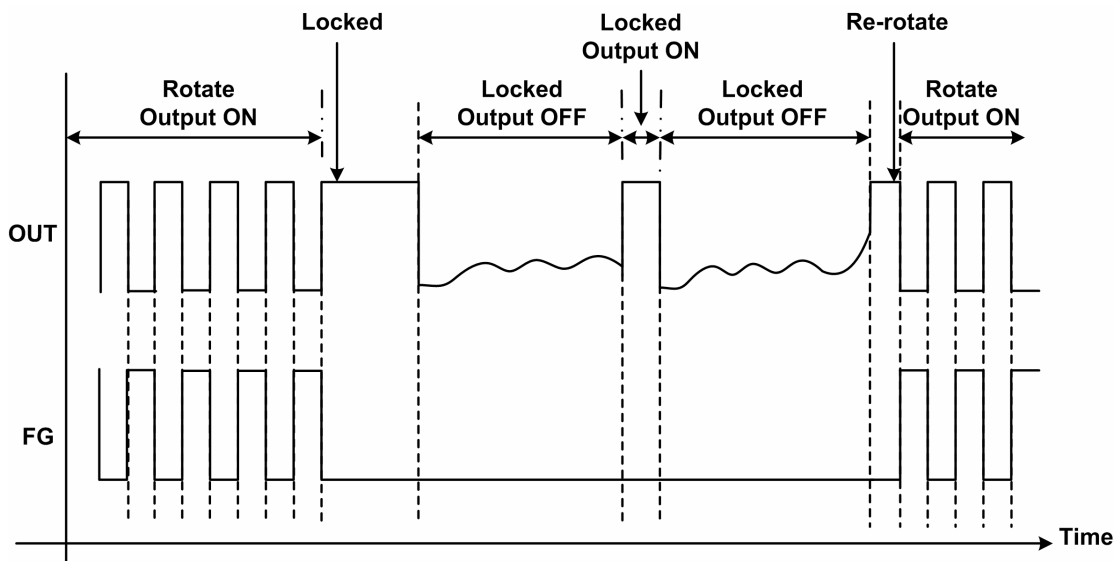

Figure 9. Lock Protection and Auto Restart

## EUM6898R/S Operation Truth Table

Mode	IN-	IN+	OUT1	OUT2	FG
Rotation (Drive)	L	H	H	L	L
	H	L	L	H	OFF
Rotation (Recirculation)	L	H	L	L	L
	H	L	L	L	OFF
Lock Protection	L	H	L	L	L
	H	L	L	L	OFF



**Thermal Shut Down (TSD)**

EUM6898R/S is built-in thermal shutdown protection function. And TSD has the temperature hysteresis.

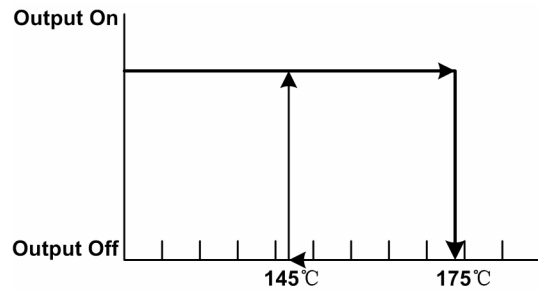

**Figure 10.**

TSD ON (Typ. 175°C): output transistor is OFF; TSD OFF (Typ. 145°C): reset ordinary motion. (It has the temperature hysteresis of 30°C <Typ.>).

**Over Current Protection (Internal OCP Function)**

A current passing through the motor coil can be detected on the internal current detection devices to prohibit a current flow large than a current limit value. The current limit value is determined by setting of the IC internal limit voltage and the internal current detection devices. The internal current limit value is 1.55A(Typ).

**Packaging Information**

**TSSOP-14 (EP)**

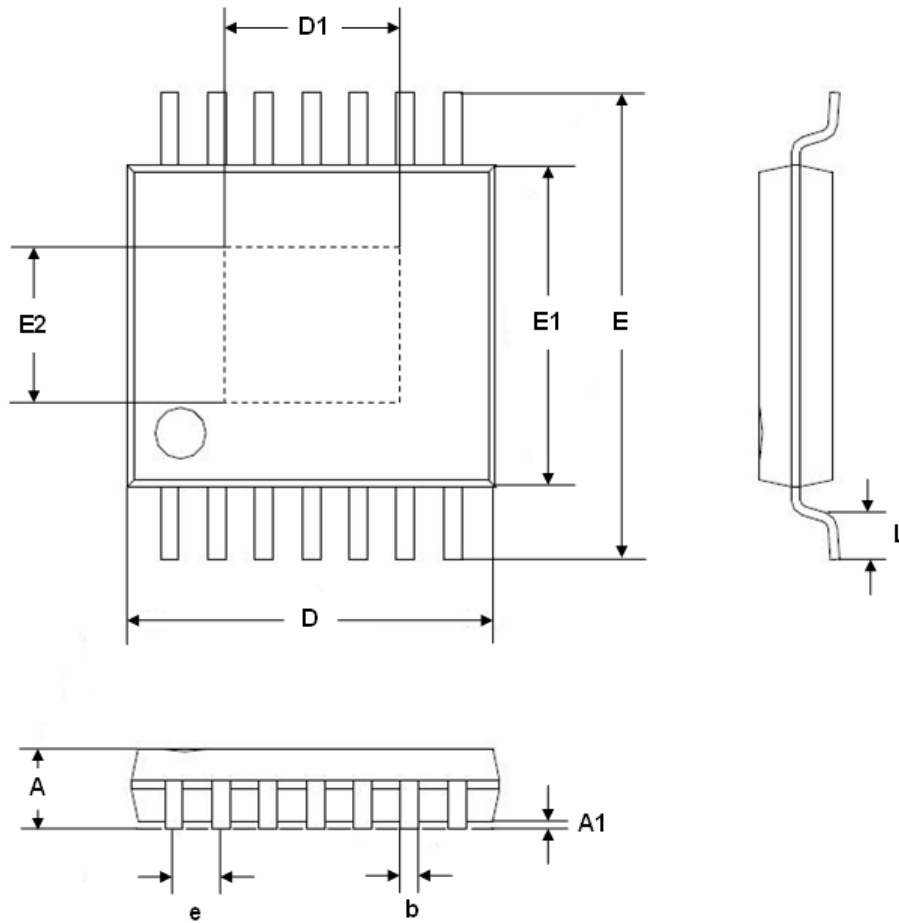

Note: Package outline drawing is for reference only.

SYMBOLS	MILLIMETERS			INCHES		
	MIN.	Normal	MAX.	MIN.	Normal	MAX.
A	-	-	1.20	-	-	0.047
A1	0.00	-	0.15	0.000	-	0.006
b	0.15	-	0.35	0.006	-	0.014
D	4.80	5.00	5.20	0.189	0.197	0.205
D1	2.60	-	3.20	0.102	-	0.126
E	6.20	6.40	6.60	0.244	0.252	0.260
E1	4.30	4.40	4.50	0.169	0.173	0.177
E2	2.50	-	3.20	0.098	-	0.126
e	0.65 REF			0.026 REF		
L	0.45	0.60	0.75	0.018	0.024	0.030