

## 4 Strings High Current White LED Driver with Boost Controller

### DESCRIPTION

The EUP2588 is a high power and high efficiency boost controller with 4-channel current sinker which is ideal for large LCD backlighting applications.

EUP2588 uses current mode, fixed frequency architecture which can clamp the inductor peak current each cycle. The switching frequency is programmable by an external frequency setting resistor. It drives an external MOSFET to boost up the output voltage from a 4.5V to 28V input supply. The EUP2588 regulates the current in each LED string to the programmed value set by an external current setting resistor. The EUP2588 current matching can achieve  $\pm 1.5\%$  and regulation accuracy can reach  $\pm 2\%$ .

A 3 $\mu$ A shutdown current and 0.85V (ILED@180mA) feedback voltage and Maximum 65V output allows for up to 18 high-power LEDs in series will greatly improve efficiency and reduce power dissipation.

The device supports pulse width modulation (PWM) brightness dimming. During digital PWM dimming, the WLED current is turned on/off at the duty cycle and frequency determined by the PWM signal on the PWMI pin.

The EUP2588 integrated multiple protect functions, such as LED Open, LED Short, Output Over Voltage, Over thermal, Input Over Current, and Under Voltage Lockout (UVLO), these protection will prevent the LCD backlight from damage.

EUP2588 is available in 16pin SOP and TSSOP (EP) packages.

### Typical Application Circuit

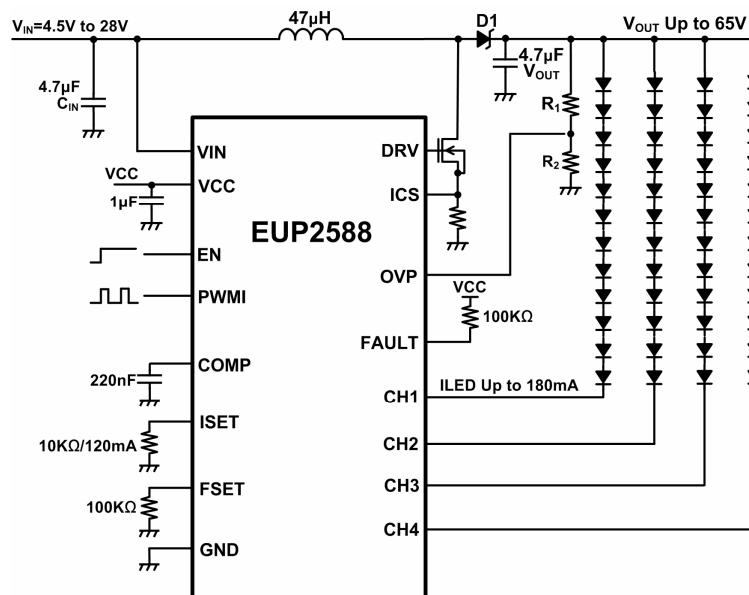

Figure 1. Typical Application Circuits

### FEATURES

- 3 $\mu$ A shutdown current
- 4 strings in parallel and up to 18 LEDs per string
- External PWM Dimming Control
- Output voltage up to 65V
- Up to 180mA Drive Capability for Each String
- Wide Input voltage range 4.5V to 28V
- Better than 1.5% LED Current Regulation Accuracy Between Strings
- Boost Switching frequency can be programmed by external resistor
- Multiple Fault Protections
  - Current Limit protection
  - Output Short circuit detection
  - Over-temperature protection
  - Output Over-voltage protection
- LED current turn off in shutdown mode
- Integrated UVLO/ Over Thermal protection
- Minimal 0.5 $\mu$ s LED On-Time regulation
- Thermal Enhanced TSSOP-16 and 16pin SOP-16 Packages
- RoHS Compliant and 100% Lead (Pb)-Free Halogen-Free

### APPLICATIONS

- LCD Monitor LED Backlighting
- LCD-TV LED Backlighting

## Pin Configurations

Package Type	Pin Configurations	Package Type	Pin Configurations
SOP-16	<p>(TOP VIEW)</p>	TSSOP-16 (EP)	<p>(TOP VIEW)</p>

## Pin Description

PIN NAME	SOP-16	TSSOP-16 (EP)	DESCRIPTION
CH4	1	5	Channel 4 LED current source. Leave it floating if not used.
ISET	2	6	Full-Scale LED Current Adjustment Pin. The resistance from ISET to GND controls the full-scale current in each LED string. ISET voltage is around 1.0V, during full lighting, $ICH_x = 1200 / R_{ISET}$ Ohm. Set $R_{ISET} = 10K\Omega$ , $ICH_x$ is set to 120mA.
OVP	3	7	Output over-voltage feedback input. Connect OVP to the tap point of the resistor divider between output and ground.
FSET	4	8	Boost Switching Frequency Program pin. Program the boost frequency by different external Resistance, and the boost converter frequency set by formula: $F_{SW} = 50000 / R_{FSET}(K\Omega)$ . If setting $F_{SET} = 100K$ , boost frequency is 500KHz.
EN	5	9	The device enable pin. A logic high signal turns on the internal LDO and enables the IC. Connect EN to VCC and make EUP2588 always ON.
ICS	6	10	Current Sense Input. During normal operation, this pin senses the voltage across the external inductor current sensing resistor for peak current mode control and also to limit the inductor current during every switching cycle.
DRV	7	11	External N-CH Power Device Gate Driver Output. This pin provides the boost converter power device gate drive signal.
VCC	8	12	5V Linear Regulator Output to power internal circuitry. Bypass VCC to GND with a ceramic capacitor of 1 $\mu$ F or greater. If $4.5V < V_{IN} < 5.5V$ , connect VCC directly to supply voltage of VIN.
VIN	9	13	Supply Voltage Input.
FAULT	10	14	EUP2588 Faults status output, it is an open drain output. If all the Channels open or Over Thermal/Over Current events happen, this pin will be pulled to low by internal open drain NMOS, otherwise, this pin will keep high by external resistor.
COMP	11	15	Boost Converter Compensation Pin. Connect a 220nF ceramic capacitor from COMP to GND. When the EUP2588 shuts down, COMP is discharged to GND.
PWMI	12	16	Brightness Control Input. To use external PWM dimming mode, apply a PWM signal on this pin for brightness control. The EUP2588 has positive dimming polarity on PWMI.
CH1	13	1	Channel 1 LED current source. Leave it floating if not used.
CH2	14	2	Channel 2 LED current source. Leave it floating if not used.
GND	15	3	Ground.
CH3	16	4	Channel 4 LED current source. Leave it floating if not used.

## Ordering Information

Order Number	Package Type	Marking	Operating Temperature Range
EUP2588DIR1	SOP-16	UXXXXX P2588	-40 °C to +85°C
EUP2588XIR1	TSSOP-16 (EP)	UXXXXX EUP2588	-40 °C to +85°C

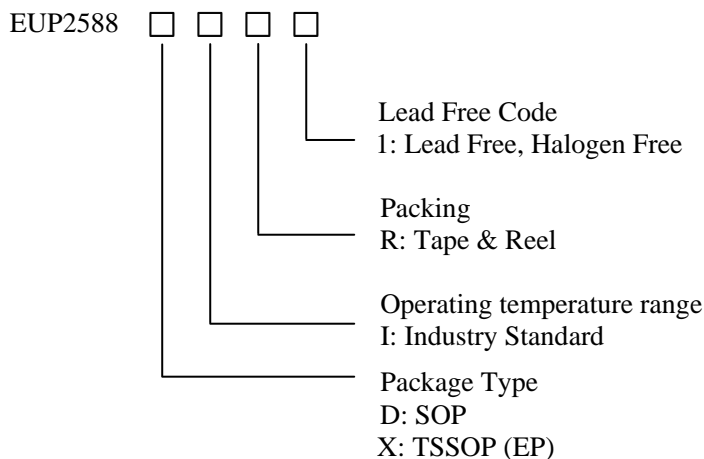

## Block Diagram

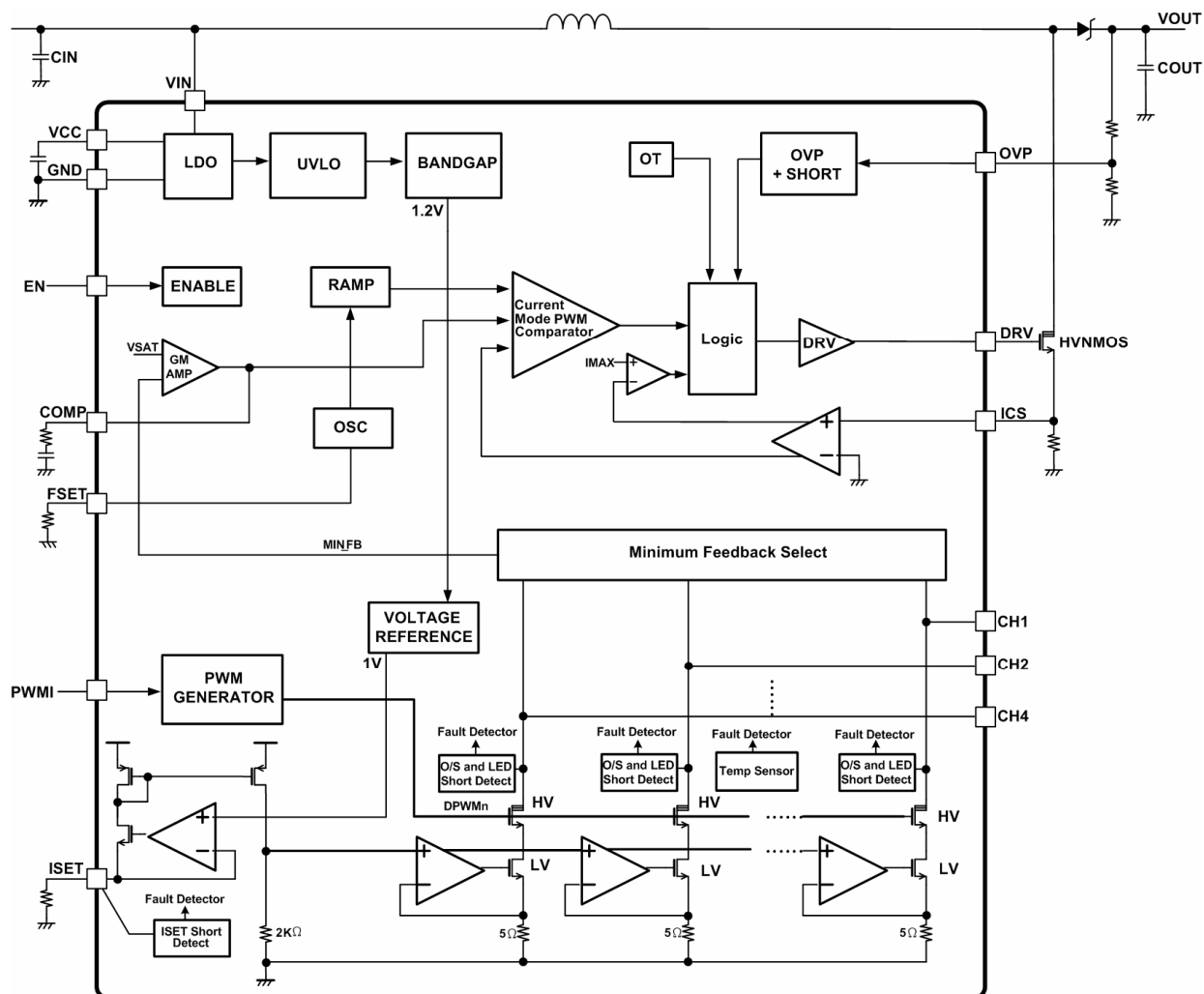

Figure 2. Block Diagram

## Absolute Maximum Ratings (1)

■	ICS, CH (n) to GND -----	-0.3V to 65V
■	VIN to GND -----	-0.3V to 30V
■	OVP, EN, PWMI, FAULT, VCC to GND -----	-0.3V to +6V
■	COMP, DRV, ISET, FSET to GND-----	-0.3V to (VCC+0.3)V
■	Continuous Power Dissipation (T <sub>A</sub> = +70°C)	
	16-Pin SOP [derate 12.5mW/°C (JEDEC high-k 2s2p) above +70°C] -----	1000mW
	16-Pin TSSOP [derate 25mW/°C (JEDEC high-k 2s2p) above +70°C] -----	2000mW
■	Operating Temperature Range -----	-40°C to +85°C
■	Maximum Junction Temperature -----	+150°C
■	Storage Temperature Range -----	-60°C to +150°C
■	Lead Temperature (soldering, 10s) -----	+300°C

## Operating Conditions (2)

■	Operating Temperature Range -----	-40°C to +85°C
■	Supply Voltage , VIN-----	4.5V to 28V
■	Maximum LED Current, ICHn -----	60mA to 180mA
■	Maximum LED Pulse Current=1mS -----	200mA

Note (1): Stress beyond those listed under “Absolute Maximum Ratings” may damage the device.

Note (2): The device is not guaranteed to function outside the recommended operating conditions.

## Electrical Characteristics

(Circuit of Figure 1, VIN=12V, GND=0V, R<sub>ISET</sub>=10kΩ, R<sub>FSET</sub>=100kΩ, V<sub>PWMI</sub>= 5V, T<sub>A</sub>= 40°C to +85°C, unless otherwise noted. Typical values are at T<sub>A</sub>= +25°C.)

Symbol	Parameter	Conditions	EUP2588			Unit
			Min.	Typ.	Max.	
VIN	VIN Supply voltage		4.5		28	V
I_VIN	VIN Supply Current	PWMI=5V		1	2	mA
I_OFF	VIN Shutdown Current	PWMI=EN=0, VIN=12V			6	μA
I_STANDBY	VIN Standby Current	EN=5V, PWMI=0V, VIN=12V		750	1200	μA
VCC	VCC Output Voltage	VEN=5V, 6V<VIN<28V, 0<I <sub>VCC</sub> <10mA	4.85	5	5.5	V
I_VCC	VCC Current Limit			50		mA
UVLO	UVLO Rising Threshold		3.7	4.1	4.4	V
UVLO_HYS	UVLO Hysteresis			0.15		V
VIH	EN High Level	VEN Rising	2.4			V
VIL	EN Low Level	VEN Falling			0.7	V
<b>Boost Converter</b>						
	DRV Sourcing Impedance	VIN=VCC=5V, IDR <sub>V</sub> =5mA		15		Ω
	DRV Sinking Impedance	VIN=VCC=5V, IDR <sub>V</sub> =5mA		4		Ω
FSW	Switching Frequency	R <sub>FSET</sub> =100KΩ	475	500	525	KHz
TON_MIN	Minimum On Time			100		nS
ICS	Boost Current Limit	Boost ON Time>100nS (DRV=Hi Time>100nS)	450	500	550	mV
GM	COMP Transconductance	ΔI <sub>COMP</sub> =±10μA		60		μs
DMAX	Maximum Duty Cycle		90	93	96	%
<b>LED Current Regulation</b>						
RCH	CHn Sink Resistance	I <sub>LEDn</sub> =120mA		5		Ω

**Electrical Characteristics (continued)**

(Circuit of Figure 1,  $V_{IN}=12V$ ,  $GND=0V$ ,  $R_{ISET}=10k\Omega$ ,  $R_{FSET}=100k\Omega$ ,  $V_{PWMI}=5V$ ,  $T_A=40^\circ C$  to  $+85^\circ C$ , unless otherwise noted. Typical values are at  $T_A=+25^\circ C$ .)

Symbol	Parameter	Conditions	EUP2588			Unit
			Min.	Typ.	Max.	
<b>LED Current Regulation</b>						
VISET	ISET Regulation Voltage			1		V
ILED	Output LED Current	RISET=10K $\Omega$	115.2	120	124.8	mA
Imatch	CHn Current matching	ILED=120mA	-1.5		1.5	%
<b>Dimming Controls</b>						
TPWMImin	Minimum PWM Pulse	In External PWM Dimming Mode		0.5		$\mu s$
VPWMH	PWMI Input High Level		2.4		VCC	V
VPWML	PWMI Input Low Level		0		0.7	V
IPWMI	PWMI Pull Down Current	$V_{PWMI}=5V$	-1		+1	$\mu A$
<b>Fault Detections</b>						
Vovp	Over-voltage Threshold on OVP	Rising Edge	1.9	2.0	2.1	V
Vhys-ovp	OVP Hysteresis	Falling Edge		70		mV
VCHx_OV	CHx Over Voltage Threshold	$V_{IN}>5.5V$	6.5	7	7.5	V
R <sub>FAULT</sub>	FAULT Sink Resistance			10		$\Omega$
Tsd	Thermal Shutdown Threshold			150		$^\circ C$
Tsd_hys	Thermal Shutdown Hysteresis			30		$^\circ C$

## Typical Operating Characteristics

( $V_{IN}=12V$ ,  $I_{SET}=20K$ ,  $FSET=330K$ ,  $Status=100K$ ,  $L=47\mu H$ ,  $C_{COMP}=22nF$ ,  $C_{OUT}=47\mu F$ )

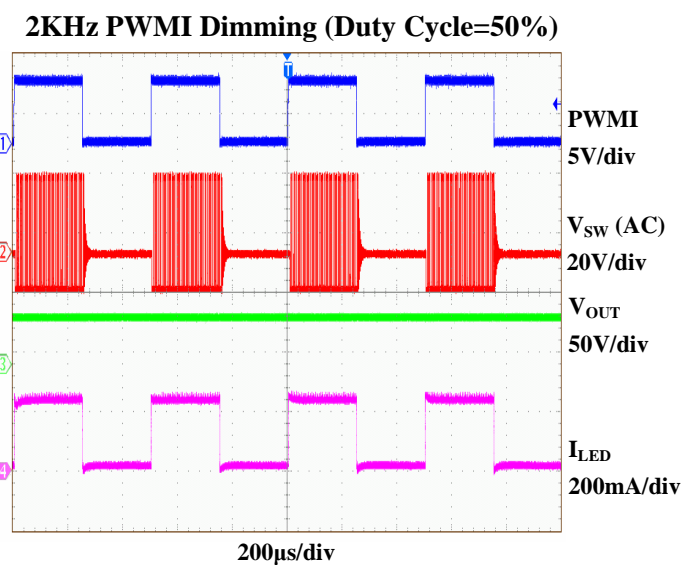
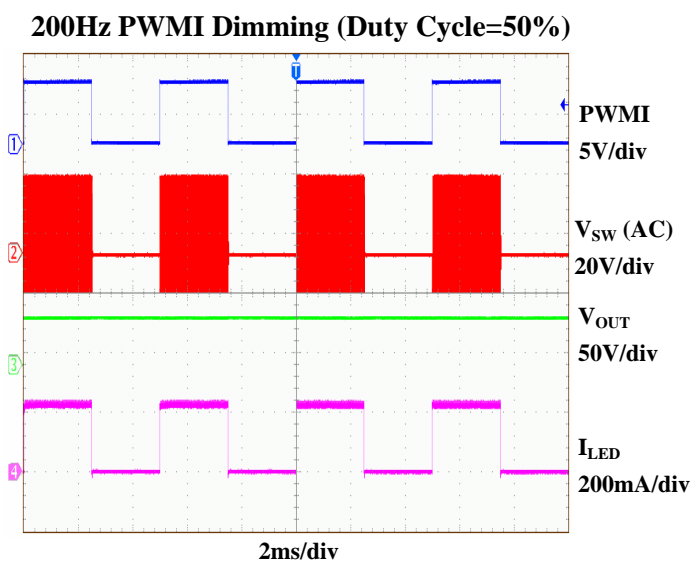
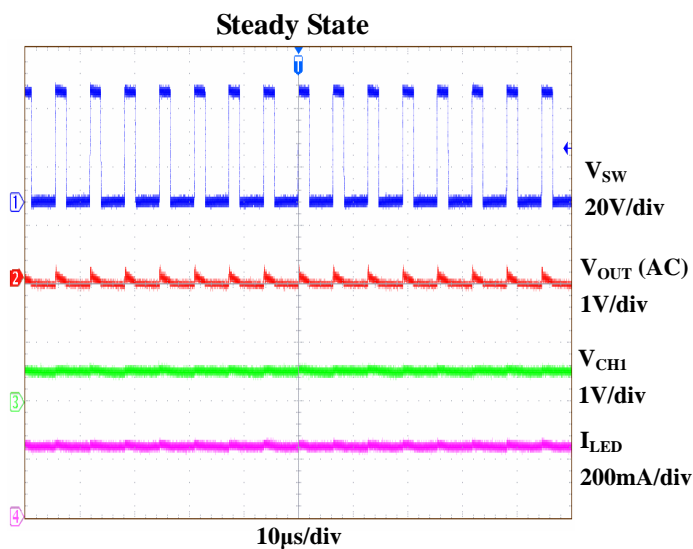
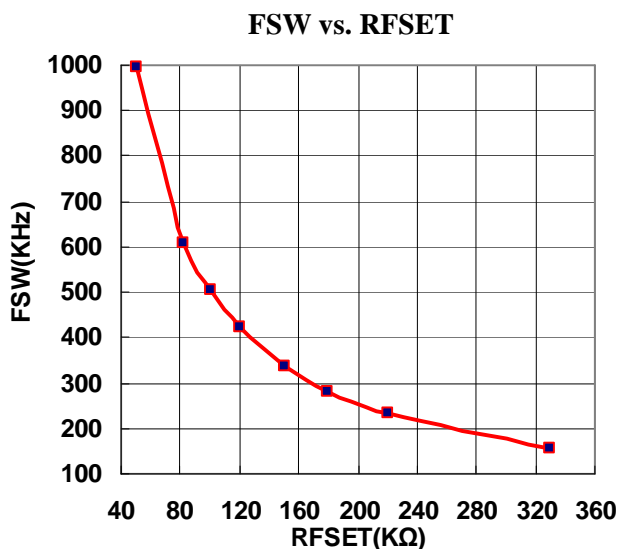
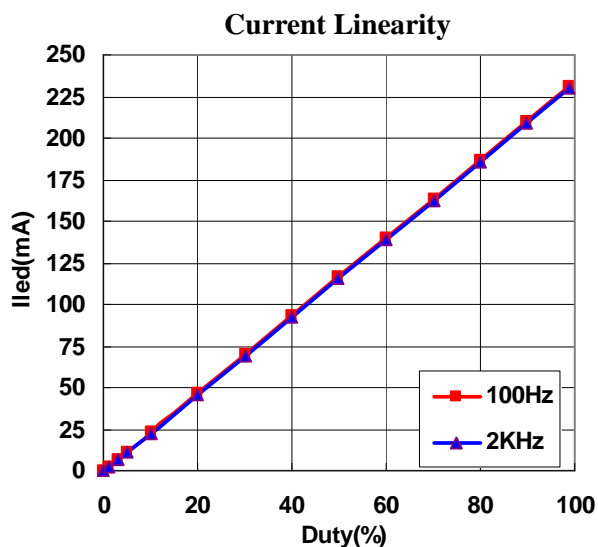
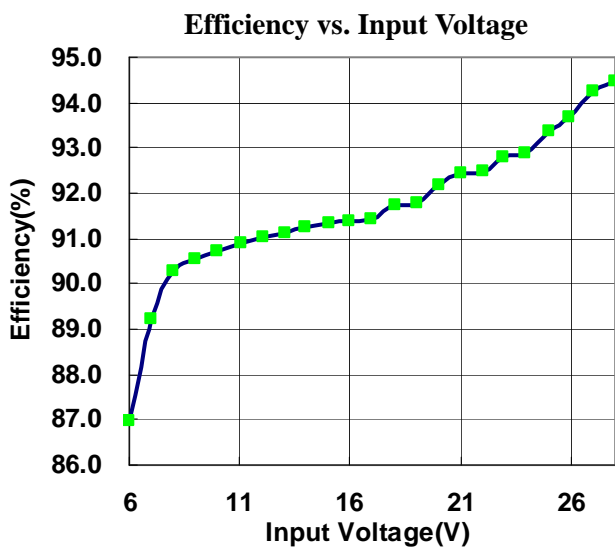

## Typical Operating Characteristics (continued)

( $V_{IN}=12V$ ,  $I_{SET}=20K$ ,  $FSET=330K$ ,  $Status=100K$ ,  $L=47\mu H$ ,  $C_{COMP}=22nF$ ,  $C_{OUT}=47\mu F$ )

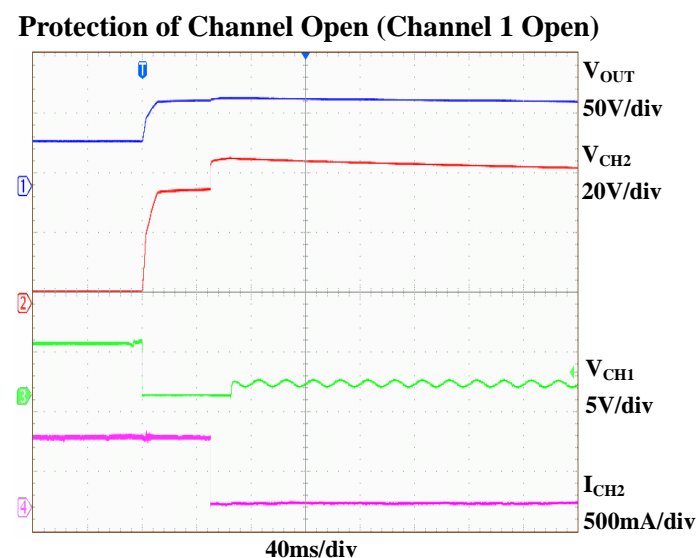
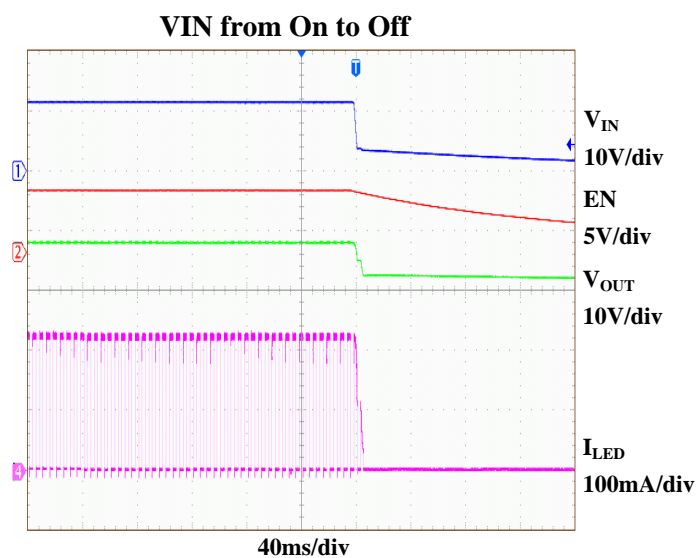
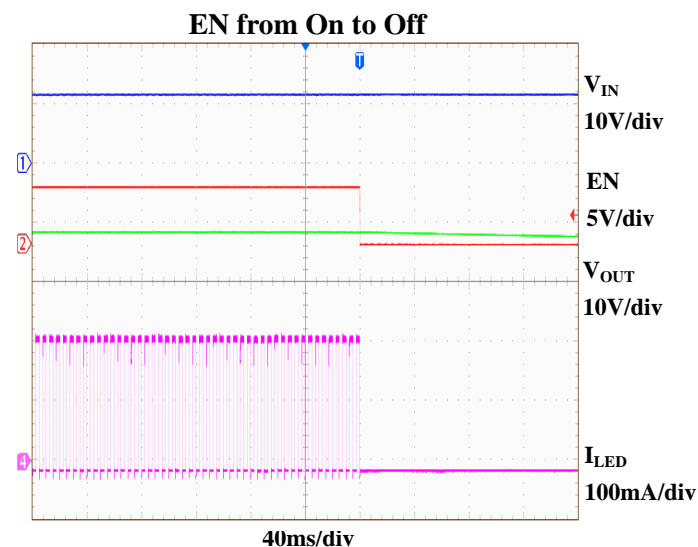
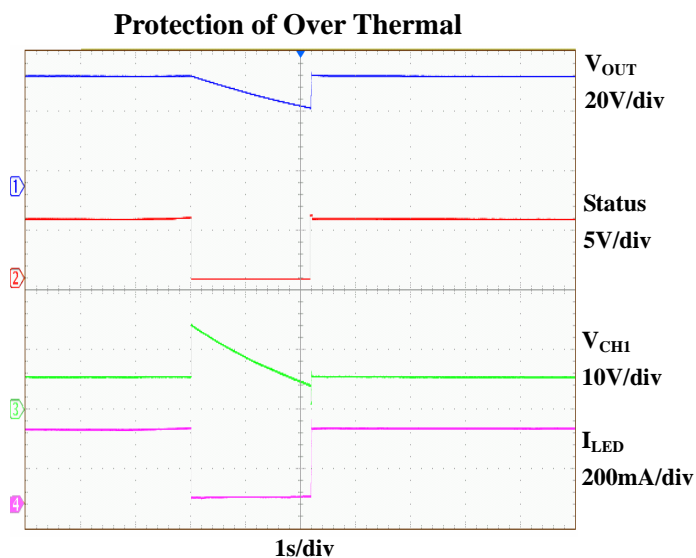
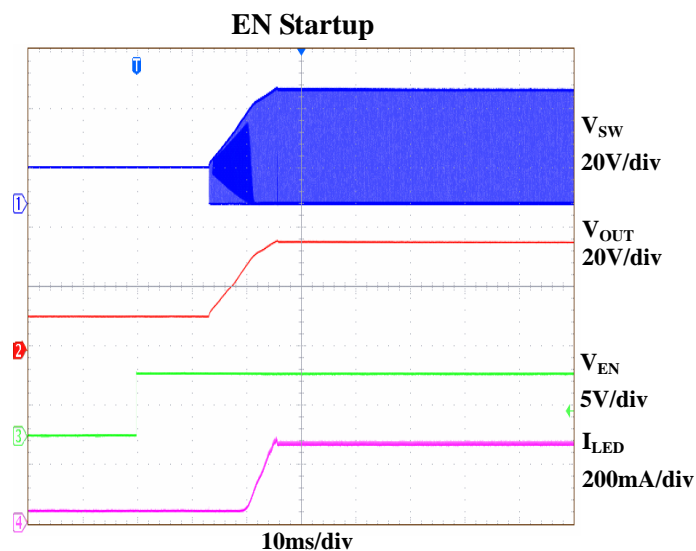
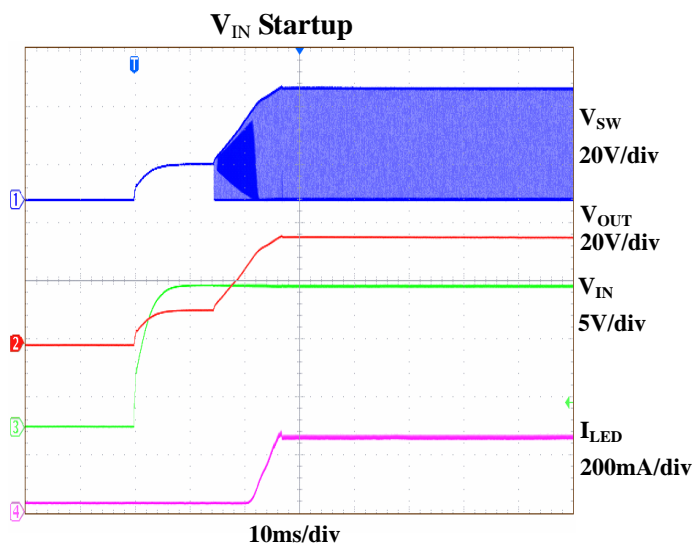

## Typical Operating Characteristics (continued)

( $V_{IN}=12V$ ,  $I_{SET}=20K$ ,  $F_{SET}=330K$ ,  $Status=100K$ ,  $L=47\mu H$ ,  $C_{COMP}=22nF$ ,  $C_{OUT}=47\mu F$ )

### Protection of Channel Short to VOUT (Channel 1 Short to VOUT)

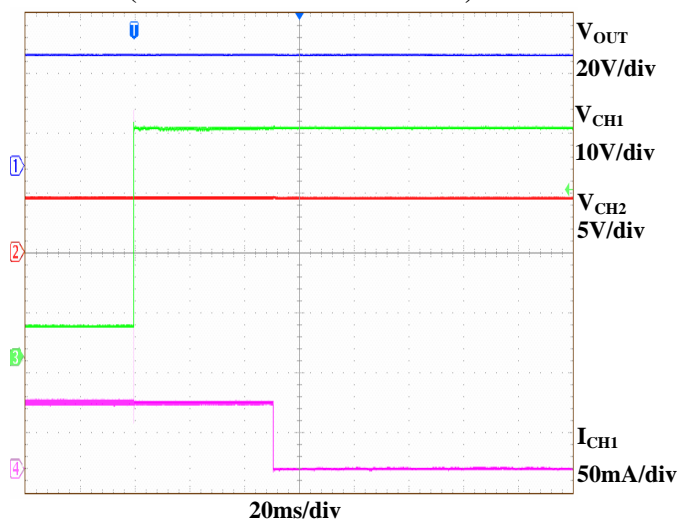

### Protection of VOUT Short to GND

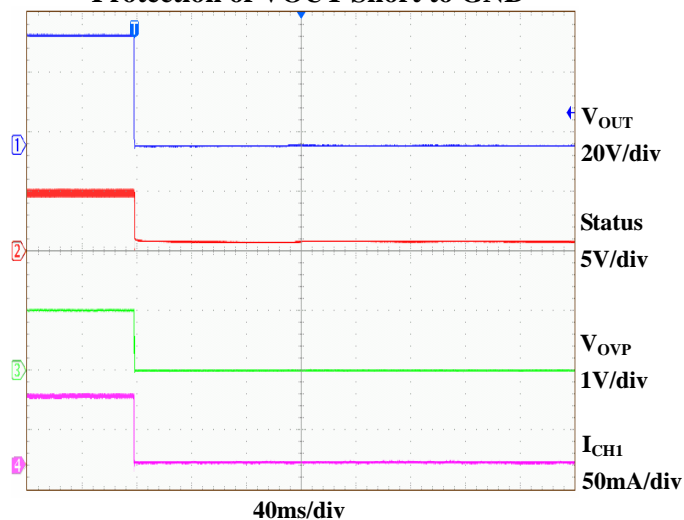

### Protection of Inductor Short

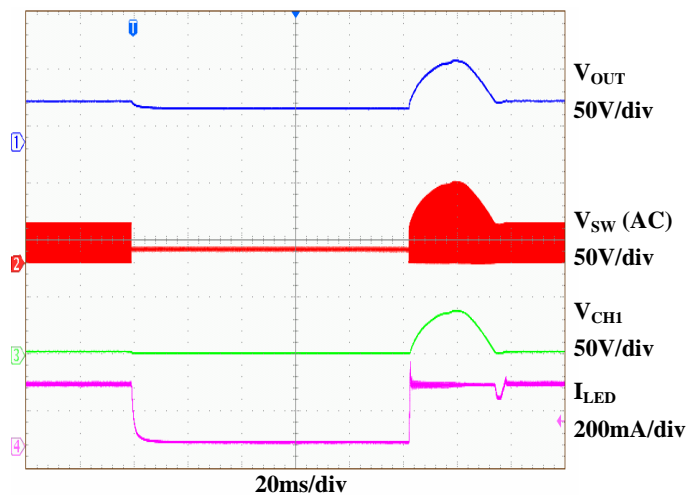



## Detailed Descriptions

The EUP2588 is a high-efficiency driver for arrays of white LEDs. It contains a fixed-frequency, current mode, PWM step-up controller, 5V linear regulator, dimming control circuit, and 4 regulated current sources (see Figure 2). When enabled, the step-up controller boosts the output voltage to provide sufficient headroom for the current sources to regulate their respective string currents. The EUP2588 features programmable switching frequency, which allows trade-offs between external component size and operating efficiency. The control architecture automatically skips pulses at light loads to improve efficiency and prevents overcharging the output capacitor. The EUP2588 supports external digital control of the LED current through a PWM logic input signal on PWMI. The EUP2588 has multiple features to protect the controller from fault conditions. Separate feedback loops limit the output voltage if one or more LEDs fail open or short. The controller features cycle-by-cycle current limit to provide consistent operation and soft-start capability. A thermal-shutdown circuit provides another level of protection. This part includes a 5V linear regulator that provides the internal bias and gate drive for the step-up controller. When an external 5V is available, the internal LDO can be overdriven to decrease power dissipation. Otherwise, connect the VIN pin to an input greater than 5.5V. An internal crude LDO keeps alive to provide power supply for internal logic and controller even EN is low, which only dissipate 3uA quiescent current.

### 5V Supply VCC and UVLO

The EUP2588 has built in 5V linear regulator VCC supply for internal control voltage. The EUP2588 includes the power on reset (POR) and under-voltage lockout (UVLO) features. POR resets the fault latches. POR occurs when VCC rises above 2.8V (typ). The controller is disabled until VCC exceeds the UVLO threshold of 4.05V (typ). Hysteresis on UVLO is approximately 150mV. The VCC should be bypassed to GND with a 0.47µF or greater ceramic capacitor.

### System Startup

When the EUP2588 is enabled, the chip checks the topology connection first. And after 8mS delay, the chip monitors the OVP pin to see if the Schottky diode is not connected or the boost output is short to GND. If the OVP voltage is lower than 70mV, the chip will be disabled. It is recommended on the start up sequence that the enable signal comes after input voltage and PWM dimming signal established.

### Step-up Converter

The converter operation frequency is programmable (from 150kHz to 1.5MHz) with a external set resistor on FSET pin, which is helpful for optimizing the external components sizes and improving the efficiency. An oscillator resistor on FSET pin sets the internal oscillator frequency for the step-up converter according to the equation:

$$F_{SW} = 50000/R_{FSET}$$

For  $R_{FSET}=100k\Omega$ , the switching frequency is set to 500kHz.

The EUP2588's fixed-frequency, current-mode, step-up controller automatically chooses the lowest active CHx voltage to regulate the output voltage. When  $I_{LED}=180mA$ , a 0.85V is setting as the minimum CHx feedback reference. The error signal is compared to the external switch current plus slope compensation to determine the switch on-time. As the load changes, the error amplifier sources or sinks current to the COMP output to deliver the required peak-inductor current. The slope-compensation signal is added to the current-sense signal to improve stability at high duty cycles.

At light-load or  $V_{out}$  near to  $V_{in}$  operation, the converter runs into the pulse-skipping mode, the FET is turned on for a minimum on-time of approximately 100ns, and then the converter discharges the power to the output in the remain period. The external MOSFET will keep off until the output voltage needs to be boosted again.

### Dimming Control

The EUP2588 provides external PWM dimming for all 4 channels LED current adjustment. This PWM signal results in PWM chopping of the current in the LEDs for all 4 channels to provide LED control. EUP2588 accepts 100Hz to 20KHz external PWM signal, and this signal with low level less than 0.7V and high level above 2.4V.

### Open String Protection

The open string protection is achieved through the over voltage protection. If one or more strings are open, the respective CHx pins are pulled to ground and the IC keeps charging the output voltage until it reach OVP threshold. Then the part will mark-off the open strings whose CHx pin voltage is less than 210mV. Once the mark off operation completes, the remaining LED strings will force the output voltage back into tight regulation. The string with the highest voltage drop is the ruling string during output regulation.

The EUP2588 always tries to light at least one string and if all strings in use are open, the EUP2588 shuts down the step-up converter. The part will maintain mark-off information until the part shuts down.

### Setting the Over Voltage Protection

The open string protection is achieved through the over voltage protection (OVP). In some cases, an LED string failure results in the feedback voltage always zero. The part then keeps boosting the output voltage higher and higher. If the output voltage reaches the programmed OVP threshold, the protection function will be triggered.

To make sure the chip functions properly, the OVP setting resistor divider must be set with a proper value. The recommended OVP point is about 1.2 times higher than the output voltage for normal operation.

$$V_{OVP} = 2.0 \times \left( \frac{R_1 + R_2}{R_2} \right)$$

## Short String Protection

The EUP2588 monitors the CHx pin voltage to judge if the short string occurs. If one or more strings are shorted, the respective CHx pins will be pulled up to the boost output and tolerate high voltage stress. If the CHx pin voltage is higher than 7V, the short string condition is detected on the respective string. When the short string fault (CHx over-voltage fault) continues for greater than 2ms, the string is marked off and disabled. Once a string is marked off, its current regulation is forced to disconnect from the output voltage loop regulation. The marked-off LED strings will be shut off totally until the part restarts. If all strings in used are short, the EUP2588 will shut down the step-up converter.

## Fault Protection

The EUP2588 has multiple features to protect the device from fault conditions. Separate feedback loops limit the output voltage under any circumstance, ensuring safe operation. Once an open string is detected, the string is disabled while other strings operate normally. The EUP2588 also features short LED detection. Table 1 lists all the EUP2588 fault protections control.

**Table 1. EUP2588 Fault Protection**

Faults	FAULT State	Boost DC-DC	WLED Current
CHx Short to GND	High, Only 4CHx OFF FAULT=Lo	Only 4CHx All OFF, Controller will Shutdown. Otherwise, Keep Normal	Mark OFF the shorted CHx, Others keep Normal
CHx Over Voltage	High, Only 4CHx OFF FAULT =Lo	Only 4CHx All OFF, Controller will Shutdown. Otherwise, Keep Normal	Mark OFF the LED Open CHx, Others keep Normal
OVP shorted to GND or Boost Schottky Diode Malfunction (VOVP<0.07V)	FAULT =Lo	Off	Off
DC-DC Boost Output Exceeds OVP Threshold (VOVP=2.0V)	VOVP>2.0V, FAULT =Lo VOVP<1.95V, FAULT =Hi	When VOVP is greater than 2.0V, the boost controller will be turned off until VOVP drops to 1.95V.	On
Thermal Fault (TJ>+150°C)	TJ>150°C, FAULT =Lo TJ<120°C, FAULT =Hi	Off first, Then Return to soft-start after TJ falls below 120°C	Off first, Then Return to soft-start after TJ falls below 120°C
EN Low	FAULT =Hi	Off	Off

**Packaging Information**

**SOP-16**

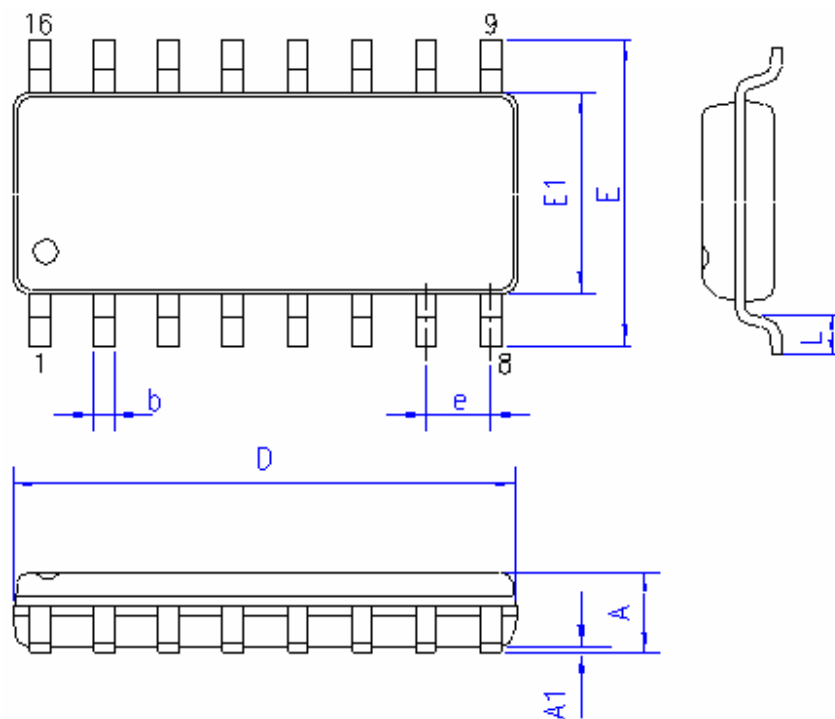

SYMBOLS	MILLIMETERS		INCHES	
	MIN.	MAX.	MIN.	MAX.
A	1.35	1.75	0.053	0.069
A1	0.10	0.25	0.004	0.010
b	0.31	0.51	0.012	0.020
D	9.90		0.389	
E1	3.90		0.153	
E	5.79	6.20	0.228	0.244
e	1.27		0.050	
L	0.38	1.27	0.015	0.050

**TSSOP-16 (EP)**

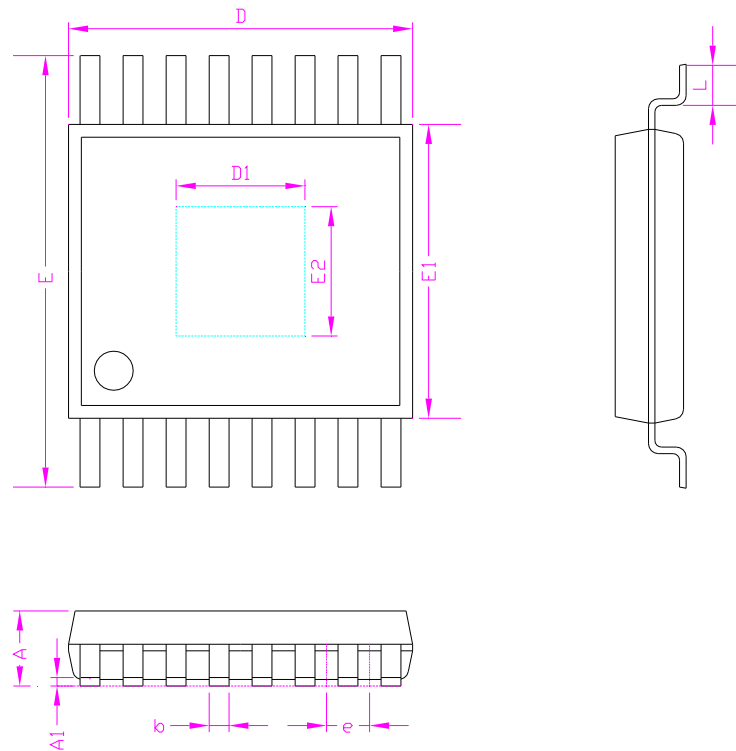

SYMBOLS	MILLIMETERS		INCHES	
	MIN.	MAX.	MIN.	MAX.
A	-	1.20	-	0.047
A1	0.00	0.15	0.000	0.006
b	0.19	0.30	0.007	0.012
E1	4.40		0.173	
D	5.00		0.197	
D1	1.98	3.00	0.078	0.118
E	6.20	6.60	0.244	0.260
E2	1.98	3.00	0.078	0.118
e	0.65		0.026	
L	0.45	0.75	0.018	0.030