



EUTECH
MICROELECTRONICS



深圳四海恒通科技
www.gofotech.com
企业QQ:2355633396 / 2355633399
您首选的IC电子零件供应商

EUP3419

Dual 1.5MHz, 1A Synchronous Step-Down Converter

DESCRIPTION

The EUP3419 contains two independent 1.5MHz constant frequency, current mode, PWM step-down converters. Each converter integrates a main switch and a synchronous rectifier for high efficiency without an external Schottky diode. The EUP3419 is ideal for powering portable equipment that runs from a single cell Lithium-Ion (Li+) battery. Each converter can supply 1A of load current from a 2.5V to 5.5V input voltage. The output voltage can be regulated as low as 0.6V. The EUP3419 can also run at 100% duty cycle for low dropout applications. 25 μ A per channel quiescent current at light loads increases efficiency and battery life.

FEATURES

- 25 μ A Quiescent Current per Channel at Light Load
- Up to 96% Efficiency
- 1.5MHz Constant Switching Frequency
- 1A Load Current on Each Channel
- 2.5V to 5.5V Input Voltage Range
- Output Voltage as Low as 0.6V
- 100% Duty Cycle in Dropout
- Short Circuit Protection
- Thermal Fault Protection
- <1 μ A Shutdown Current
- Soft Start Function
- 3mm \times 3mm TDFN-10 Package
- RoHS Compliant and 100% Lead(Pb)-Free Halogen-Free

APPLICATIONS

- Cellular and Smart Phones
- Microprocessors and DSP Core Supplies
- PDAs and Portable Media Players
- Wireless and DSL Modems
- Digital Still and Video Cameras

Typical Application Circuit

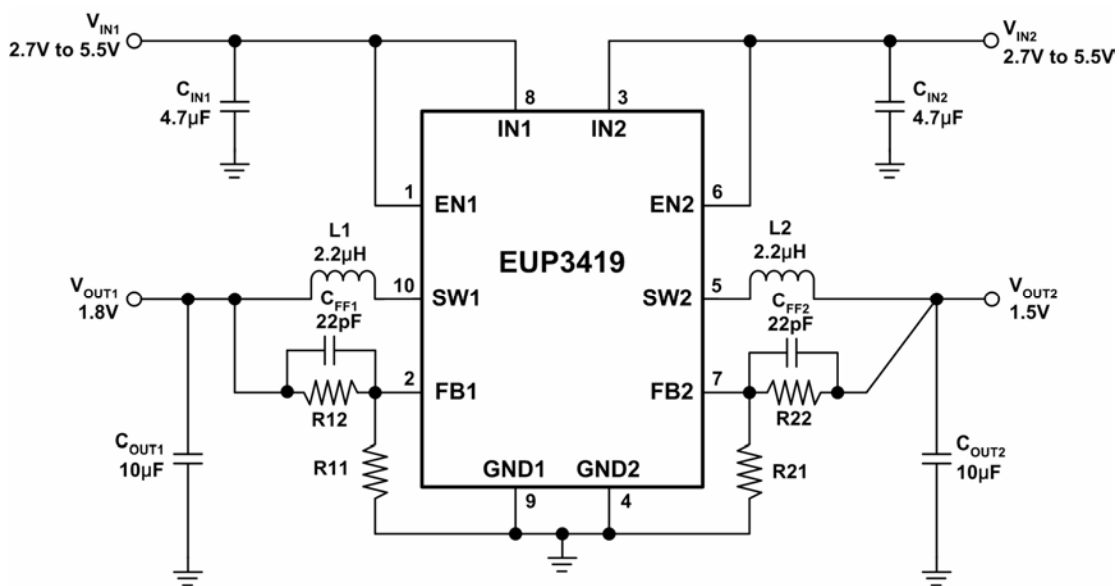

Figure 1. Adjustable Voltage Regulator

Block Diagram

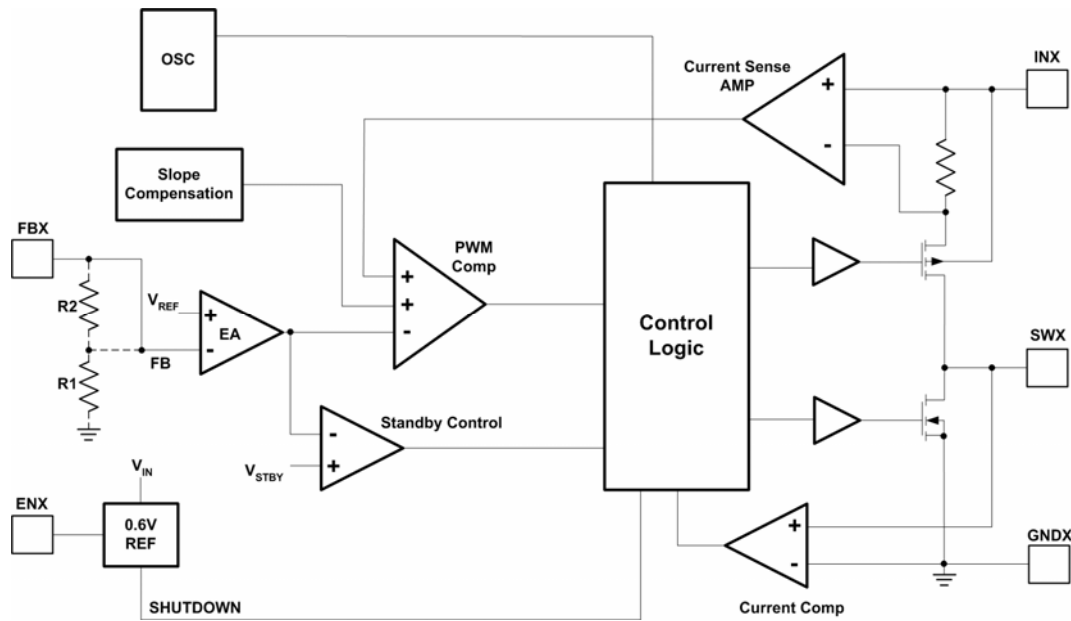

Figure 2.

Pin Configurations

Package Type	Pin Configurations
TDFN-10	<p>(TOP VIEW)</p> <p>EN1 1 SW1 10 FB1 2 GND1 9 IN2 3 IN1 8 GND2 4 FB2 7 SW2 5 EN2 6</p>

Pin Description

PIN	PIN	DESCRIPTION
EN1	1	Channel 1 Enable Control Input. Drive EN1 above 1.5V to turn on the Channel 1. Drive EN1 below 0.3V to turn it off (shutdown current < 0.1μA). Do not leave EN1 floating.
FB1	2	Channel 1 Feedback.
IN2	3	Channel 2 Supply Input.
GND2	4	Ground 2.
SW2	5	Channel 2 Switch Node Connection to Inductor. This pin connects to the drains of the internal main and synchronous power MOSFET switches.
EN2	6	Channel 2 Enable Control Input. Drive EN2 above 1.5V to turn on the Channel 2. Drive EN2 below 0.3V to turn it off (shutdown current < 0.1μA). Do not leave EN2 floating.
FB2	7	Channel 2 Feedback.
IN1	8	Channel 1 Supply Input.
GND1	9	Ground 1.
SW1	10	Channel 1 Switch Node Connection to Inductor. This pin connects to the drains of the internal main and synchronous power MOSFET switches.

Ordering Information

Order Number	Package Type	Marking	Operating Temperature Range
EUP3419JIR1	TDFN-10	XXXXX P3419 20	-40°C to +85°C

EUP3419

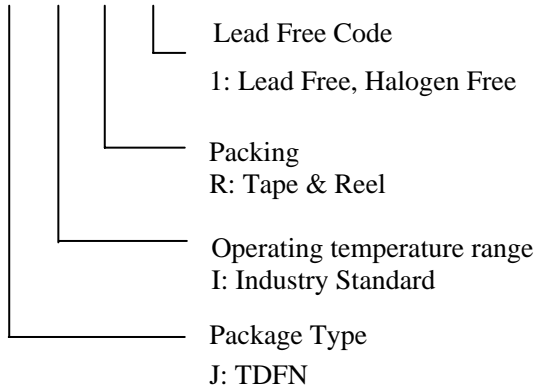

Absolute Maximum Ratings (1)

- V_{INX} to GND ----- -0.3V to 6V
- V_{SWX} to GND ----- -0.3V to $V_{INX}+0.3V$
- V_{FBX}, V_{ENX} to GND ----- -0.3V to V_{INX}
- Junction Temperature ----- 125°C
- Storage Temperature ----- -65°C to +150°C
- Lead Temp (Soldering, 10sec) ----- 260°C

Recommended Operating Conditions (2)

- Supply Voltage, V_{INX} ----- 2.5V to 5.5V
- Output Voltage, V_{OUTX} ----- 0.6V to 5V
- Operating Temperature ----- -40°C to +85°C

Note (1): Stress beyond those listed under “Absolute Maximum Ratings” may damage the device.

Note (2): The device is not guaranteed to function outside the recommended operating conditions.

Electrical Characteristics

$V_{INX}=V_{ENX}=3.6V, T_A=+25^\circ C$, Unless otherwise specified.

Symbol	Parameter		Conditions	EUP3419			Unit
				Min	Typ	Max.	
V_{INX}	Input Voltage Range			2.5		5.5	V
I_{FBX}	Feedback Current			-30		+30	nA
I_Q	Quiescent Current	Active Mode	$V_{FBX}=0.5V, SWX$ Open		270	370	μA
		Standby Mode	$V_{FBX}=0.7V, SWX$ Open		25	35	
I_{SHDN}	Each converter Shutdown Current		$V_{ENX}=0V, V_{INX}=5V$			1	μA
I_{PK}	Peak Inductor Current		$V_{INX}=5V$		1.35		A
V_{FBX}	Regulator Feedback Voltage (Note 3)		$T_A=25$	0.588	0.6	0.612	V
			$-40 \leq T_A \leq 85$	0.585	0.6	0.615	
ΔV_{OUTX}	Output Voltage Line Regulation		$V_{INX}=2.5V$ to $5.5V, I_{LOAD}=200mA$		0.25	0.4	%/V
ΔV_{FBX}	Reference Voltage Line Regulation		$V_{INX}=2.5V$ to $5.5V$		0.25	0.4	%/V
$\Delta V_{LOADREG}$	Output Voltage Load Regulation		$I_{LOAD}=200mA$ to $1000mA$		0.4		%
f_{OSC}	Each converter Oscillator Frequency (Note 3)		$V_{FBX}=0.55V$	1.2	1.5	1.8	MHz
			$V_{FBX}=0$		0.4		
R_{PFET}	$R_{DS(ON)}$ of P-Channel FET		$I_{SWX}=200mA$		0.28	0.4	Ω
R_{NFET}	$R_{DS(ON)}$ of N-Channel FET		$I_{SWX}= -200mA$		0.3	0.4	Ω
I_{LSWX}	SW Leakage Current		$V_{ENX}=0V, V_{SWX}=0$ or $5V, V_{INX}=5V$			± 1	μA
V_{ENX}	EN Threshold		$-40 \leq T_A \leq 85$	0.3	1.0	1.5	V
I_{ENX}	EN Leakage Current		$-40 \leq T_A \leq 85$			1	μA

Note (3): The EUP3419 is tested in a proprietary test mode.

Typical Operating Characteristics

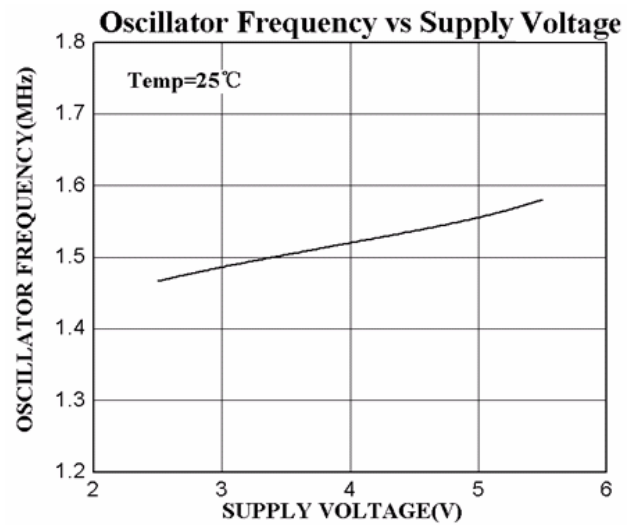
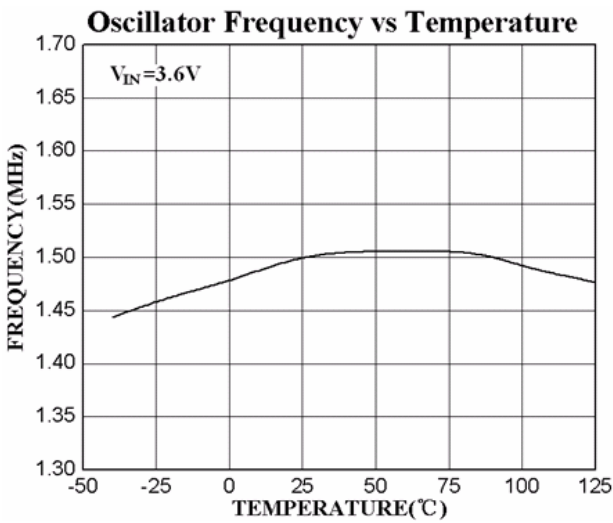
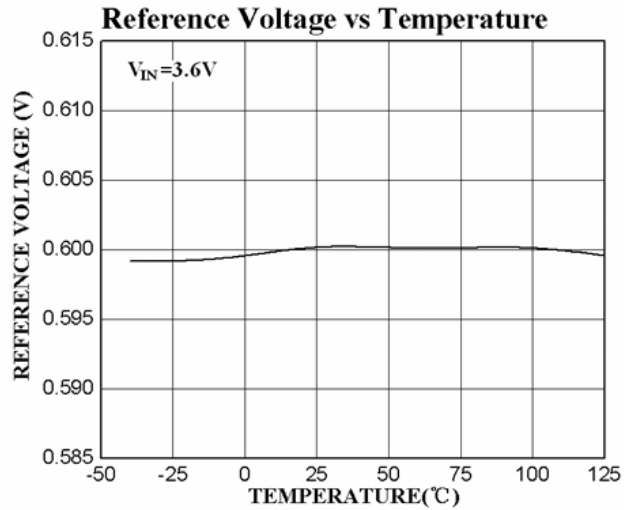
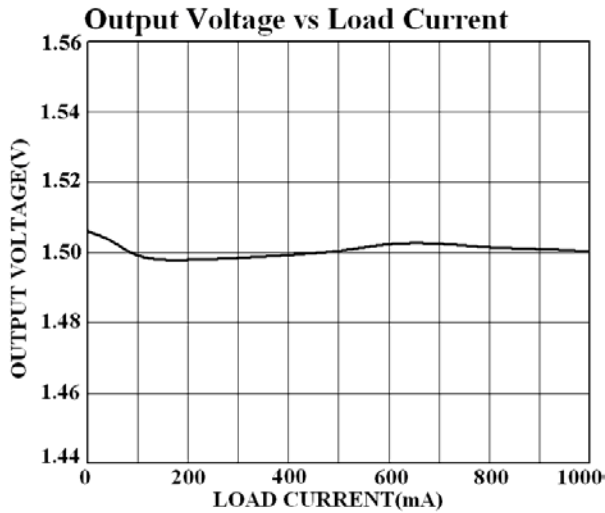
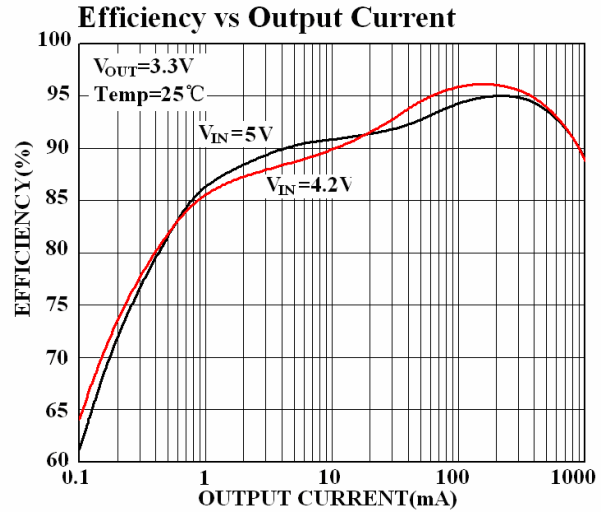
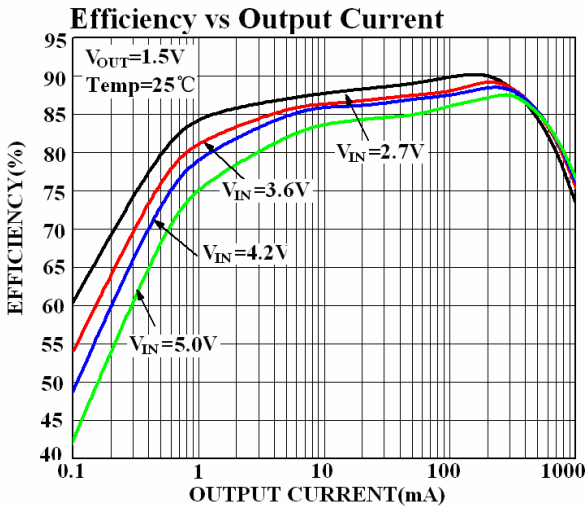

Typical Operating Characteristics (continued)

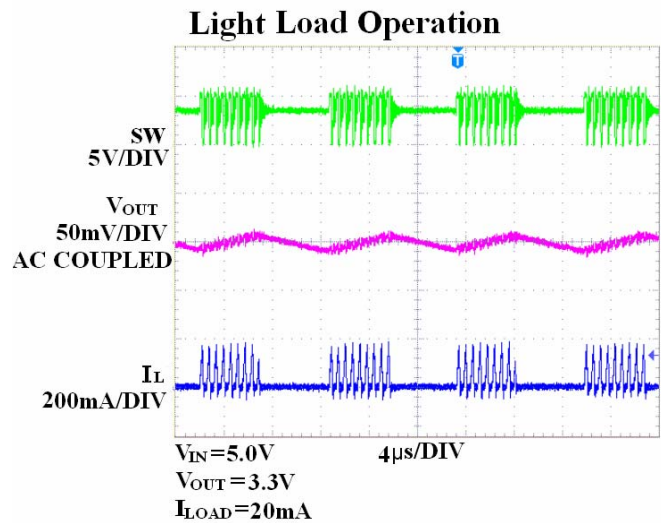
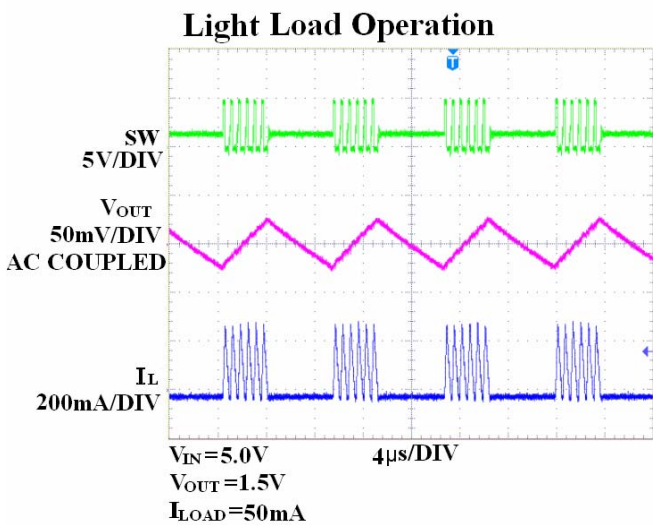
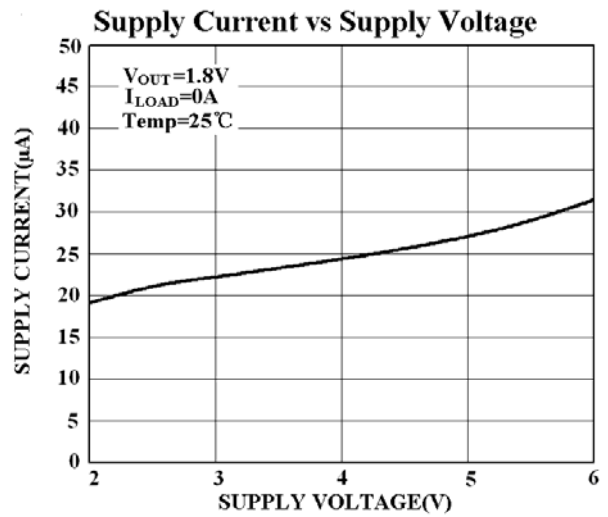
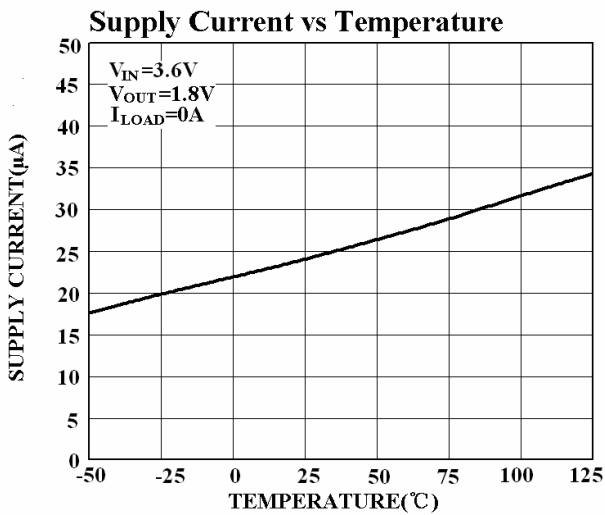
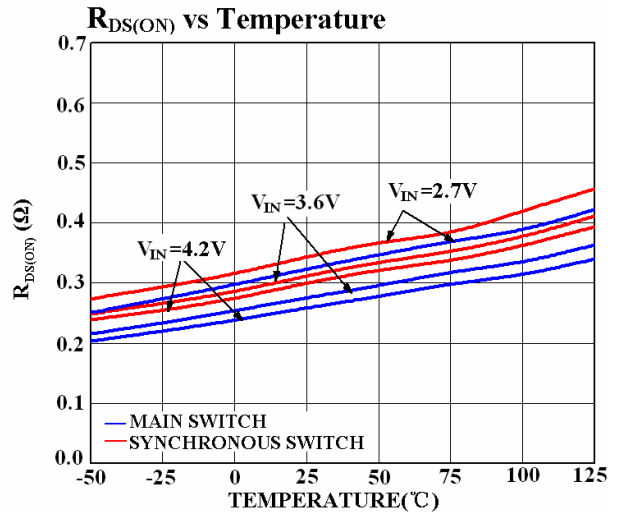
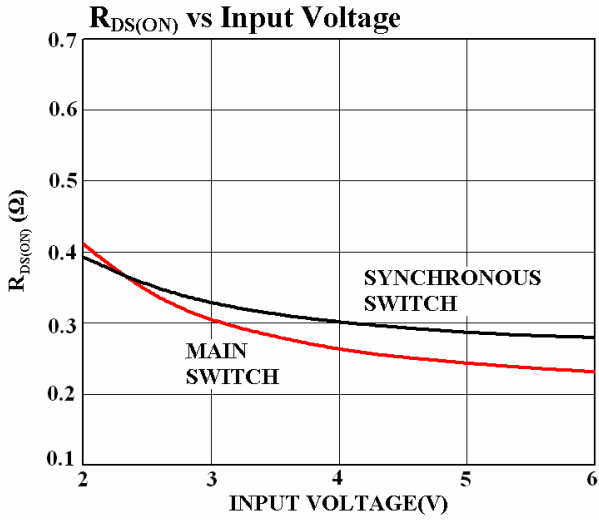

Typical Operating Characteristics (continued)

Heavy Load Operation

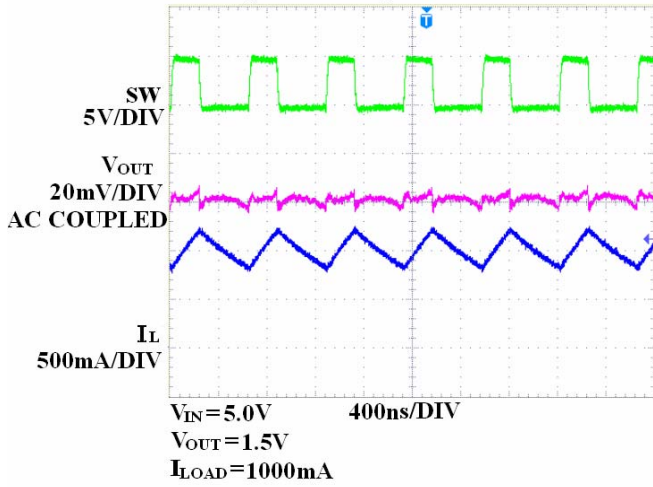

Heavy Load Operation

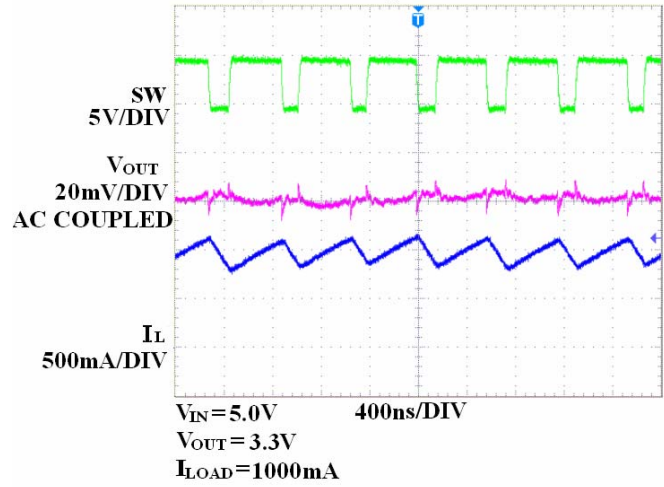

Load Step

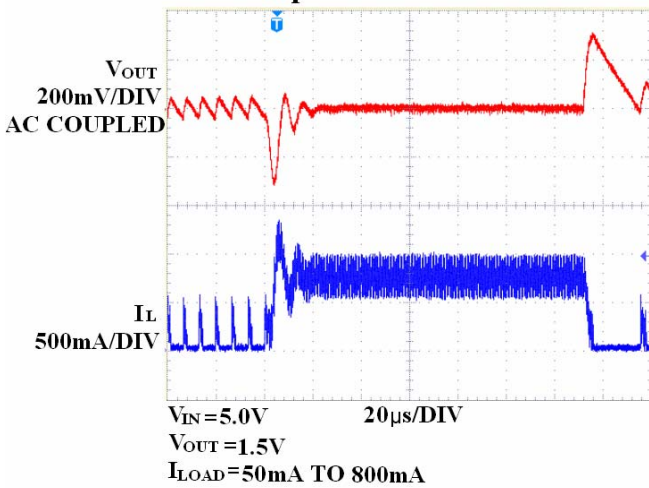

Load Step

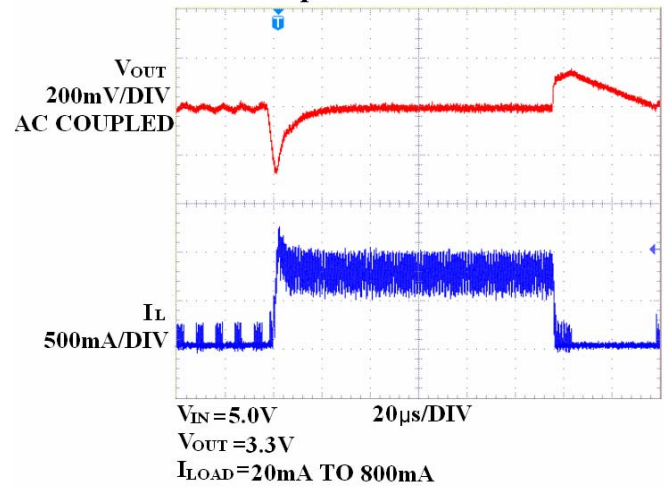

Start-Up from Shutdown

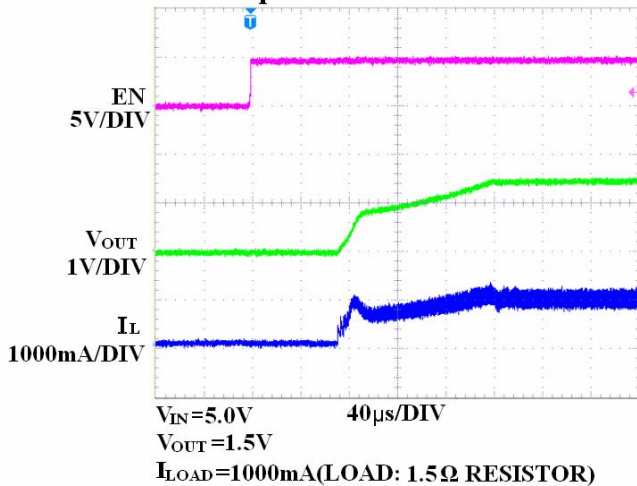

Start-Up from Shutdown

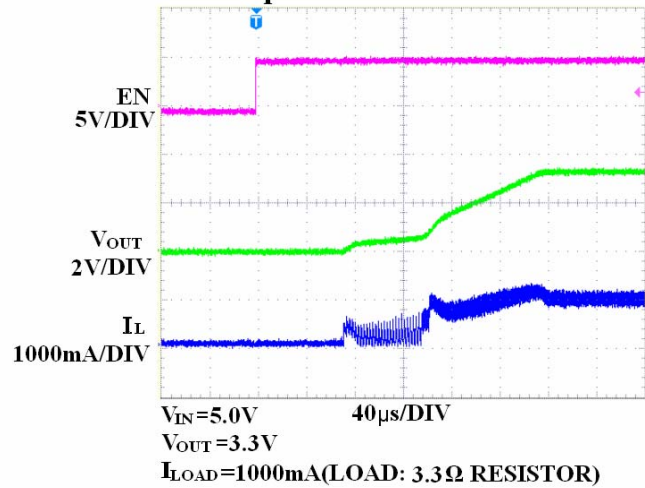

Operation

The EUP3419 has dual independent slope-compensated constant frequency current mode PWM step-down converters. Both the main (P-channel MOSFET) and synchronous (N-channel MOSFET) switches are internal. During normal operation, the EUP3419 regulates output voltage by switching at a constant frequency and then modulating the power transferred to the load each cycle using PWM comparator. The duty cycle is controlled by three weighted differential signals: the output of error amplifier, the main switch sense voltage and the slope-compensation ramp. It modulates output power by adjusting the inductor-peak current during the first half of each cycle. An N-channel, synchronous switch turns on during the second half of each cycle (off time). When the inductor current starts to reverse or when the PWM reaches the end of the oscillator period, the synchronous switch turns off. This keeps excess current from the output capacitor to GND, or through the main and synchronous switch to GND.

Power Save Mode

In order to improve the efficiency, EUP3419 enters power save mode operation when the load current is low. In power save mode, the process of operation can be divided into active mode and standby mode. In active mode, the peak current of the inductor is set to approximately 200mA regardless of the output load. In standby mode, the power MOSFETs and any unneeded circuitry are turned off, reducing the quiescent current to 25µA. The load current is being supplied solely from the output capacitor in standby state. And the intervals of active state decrease with the increase of load current until the standby state disappears. The power save mode operation increases efficiency greatly at light loads.

Application Information

Inductor Selection

The output inductor is selected to limit the ripple current to some predetermined value, typically 20%~40% of the full load current at the maximum input voltage. Large value inductors lower ripple currents. Higher V_{IN} or V_{OUT} also increases the ripple current as shown in equation. A reasonable starting point for setting ripple current is $\Delta I_L=400\text{mA}$ (40% of 1000mA).

$$\Delta I_L = \frac{1}{(f)(L)} V_{OUT} \left(1 - \frac{V_{OUT}}{V_{IN}} \right)$$

The DC current rating of the inductor should be at least equal to the maximum load current plus half the ripple current to prevent core saturation. Thus, a 1200mA rated inductor should be enough for most applications (1000mA+200mA). For better efficiency, choose a low DC-resistance inductor.

C_{IN} and C_{OUT} Selection

In continuous mode, the source current of the top MOSFET is a square wave of duty cycle V_{OUT}/V_{IN} . The primary function of the input capacitor is to provide a low impedance loop for the edges of pulsed current drawn by the EUP3419. A low ESR input capacitor sized for the maximum RMS current must be used. The size required will vary depending on the load, output voltage and input voltage source impedance characteristics. A typical value is around 4.7µF.

The input capacitor RMS current varies with the input voltage and the output voltage. The equation for the maximum RMS current in the input capacitor is:

$$I_{RMS} = I_O \times \sqrt{\frac{V_O}{V_{IN}} \times \left(1 - \frac{V_O}{V_{IN}} \right)}$$

The output capacitor C_{OUT} has a strong effect on loop stability.

The selection of C_{OUT} is driven by the required effective series resistance (ESR).

ESR is a direct function of the volume of the capacitor; that is, physically larger capacitors have lower ESR. Once the ESR requirement for C_{OUT} has been met, the RMS current rating generally far exceeds the $I_{RIPPLE(P-P)}$ requirement. The output ripple ΔV_{OUT} is determined by:

$$\Delta V_{OUT} \cong \Delta I_L \left(\text{ESR} + \frac{1}{8fC_{OUT}} \right)$$

When choosing the input and output ceramic capacitors, choose the X5R or X7R dielectric formulations. These dielectrics have the best temperature and voltage characteristics of all the ceramics for a given value and size.

Output Voltage Programming

The output voltage is set by a resistive divider according to the following formula:

$$V_{OUT} = 0.6V \left(1 + \frac{R2}{R1} \right)$$

The external resistive divider is connected to the output, allowing remote voltage sensing as shown in below figure. The recommended components for each channel are shown in the table below.

Bill of Materials ($V_{IN}=5V$, $I_{OUTMAX}=1A$)

V_{OUT} (V)	Description					
	C_{IN} (µF)	C_{OUT} (µF)	L (µH)	R1 (kΩ)	R2 (kΩ)	C_{FF} (pF)
3.3	4.7	10	2.2	75	330	22
1.8	4.7	10	2.2	165	330	22
1.5	4.7	10	2.2	220	330	22
1.2	4.7	10	2.2	330	330	22

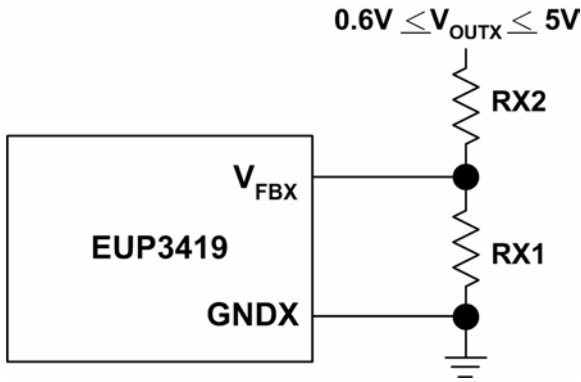

Thermal Considerations

To avoid the EUP3419 from exceeding the maximum junction temperature, the user will need to do a thermal analysis. The goal of the thermal analysis is to determine whether the operating conditions exceed the maximum junction temperature of the part. The temperature rise is given by:

$$T_R = (P_D)(\theta_{JA})$$

Where $P_D = I_{LOAD}^2 \times R_{DS(ON)}$ is the power dissipated by the regulator ; θ_{JA} is the thermal resistance from the junction of the die to the ambient temperature.

The junction temperature, T_J , is given by:

$$T_J = T_A + T_R$$

Where T_A is the ambient temperature.

T_J should be below the maximum junction temperature of 125°C.

PC Board Layout Checklist

When laying out the printed circuit board, the following guidelines should be used to ensure proper operation of the EUP3419.

1. The input capacitor C_{INX} should connect to INX as closely as possible. This capacitor provides the AC current to the internal power MOSFETs.
2. The power traces, consisting of the GNDX trace, the SWX trace and the INX trace should be kept short, direct and wide.
3. The FBX pin should connect directly to the feedback resistors. The resistive divider R11/R12 and R21/R22 must be connected between the C_{OUTX} and ground.
4. Keep the switching node, SWX, away from the sensitive FBX node.

Packaging Information

TDFN-10

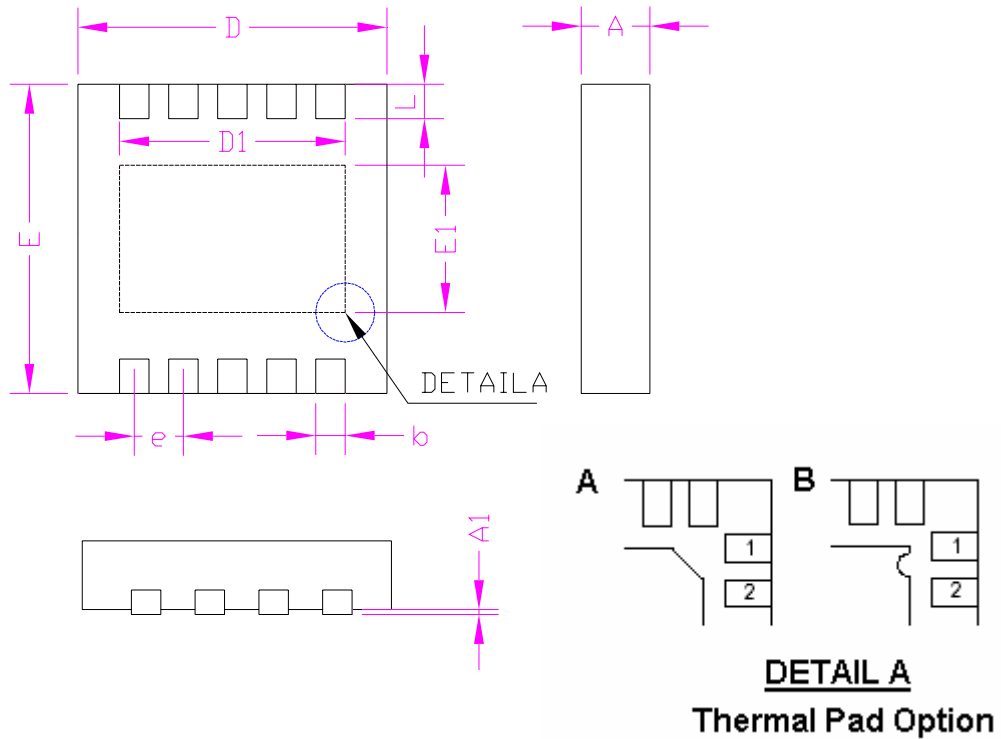

SYMBOLS	MILLIMETERS		INCHES	
	MIN.	MAX.	MIN.	MAX.
A	0.70	0.80	0.028	0.031
A1	0.00	0.05	0.000	0.002
D	2.90	3.10	0.114	0.122
E1	1.70		0.067	
E	2.90	3.10	0.114	0.122
L	0.30	0.50	0.012	0.020
b	0.18	0.30	0.007	0.012
e	0.50		0.020	
D1	2.40		0.094	