

High Efficiency, Synchronous Step-Down Controller

DESCRIPTION

The EUP7117 is a high-efficiency, low power synchronous buck controller for a core logic power supply in notebook applications. Two external N-channel MOSFETs are needed by the controller to generate an output voltage as low as 0.75V and output current up to 15A from an input supply (1.8V to 28V). EUP7117 features two operation modes: the pulse-skipping mode for high efficiency at light load and the forced PWM mode for low noise applications.

The EUP7117 automatically adjusts operating frequency to achieve fast transient response during load transient. EUP7117 has built in output monitoring, positive and negative current limit, over-voltage protection, under-voltage protection and thermal shutdown. EUP7117 requires a 5V(4.5V~5.5V) power supply to power internal control circuitry and gate drivers.

The EUP7117 is available in the 14 pin TSSOP package and specified from -40°C to +85°C.

FEATURES

- Input Voltage Range:1.8V~28V
- Output Voltage Range:0.75V~5.5V
- Adjustable Frequency 100kHz to 600kHz
- PWM Mode with 100ns Load Step Response
- Selectable Operating Modes: Pulse-Skipping Mode and Forced PWM Mode
- <1% Initial Reference Accuracy
- Typically 4μA Shutdown Current
- Over-Current Sensing from Low Side $R_{DS(On)}$ with 4500ppm/°C Temperature Compensation
- Positive and Negative Over-Current Limit
- Built in Bootstrap Diode
- OVP/UVF and Thermal Shutdown
- Power Good Detection
- Soft-Start and Soft-Stop
- Available in TSSOP-14 Package
- RoHS Compliant and 100% Lead(Pb)-Free

APPLICATIONS

- Notebooks
- I/O Supplies
- System Power Supplies

Typical Application Circuit

www.DataSheet4U.com

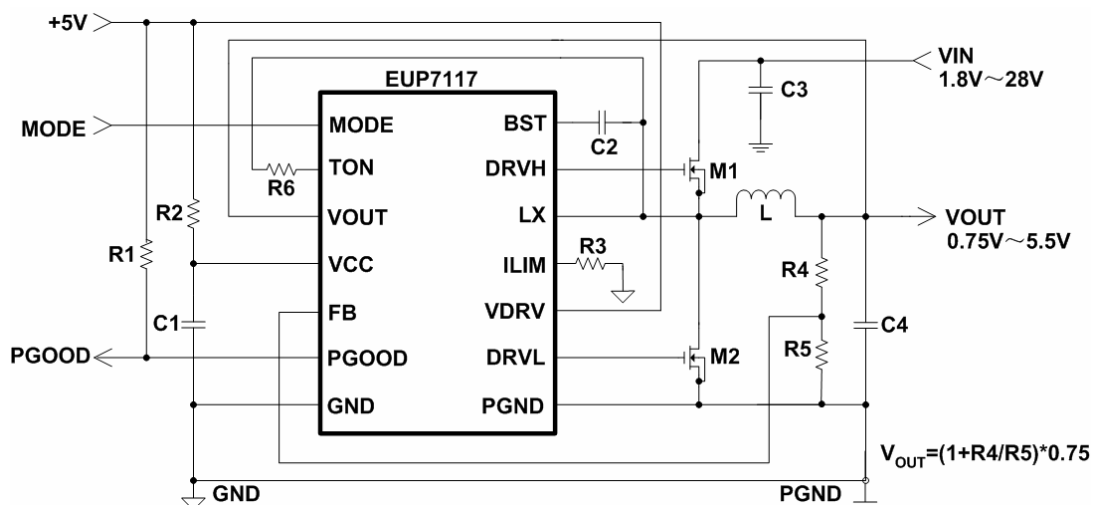

Figure.1 Typical Application Circuit