

300mA, High PSRR Low-Noise LDO

DESCRIPTION

The EUP7917 is an efficient, CMOS voltage regulator optimized for ultra-low-noise applications. It offers high output accuracy, extremely low dropout voltage, low ground current and fast start-up time. The EUP7917 provides a very low noise output, ideal for RF applications where a clean voltage source is required. A noise bypass pin is also available for further reduction of output noise.

Designed specifically for handheld and battery-powered devices, the EUP7917 provides a TTL-logic-compatible enable pin. When disabled, power consumption drops nearly to zero.

The EUP7917 also works with low-ESR ceramic capacitors, reducing the amount of board space necessary for power applications, critical in handheld wireless devices.

Available in the SC-70 and SOT23-5 package, the EUP7917 offers a wide range of output voltages. Key features include current limit, thermal shutdown and faster transient response.

FEATURES

- Space-Saving 5-pin SC-70 Package
- 2.5V to 6V Input Voltage Range
- 50 μ V(rms) Output Noise
- 250mV Dropout @ 300mA
- 75dB PSRR at 1kHz
- Low 70 μ A Ground Current
- Up to 300mA Output Current
- Stability with 1 μ F Ceramic Output Capacitors
- Excellent Load/Line Transient
- Thermal Shutdown and Current Limit Protection
- Available in 1.2V, 1.3V, 1.5V, 1.8V, 1.85V, 2.5V, 2.8V, 2.85V, 2.9V, 3.0V, 3.3V, 3.5V, 4.8V and Adjustable Voltages
- RoHS Compliant and 100% Lead (Pb)-Free

APPLICATIONS

- Cellular Phones
- Bluetooth Portable Radios and Accessories
- PDA and Palmtop Computers
- Consumer/Personal Electronics

Block Diagram

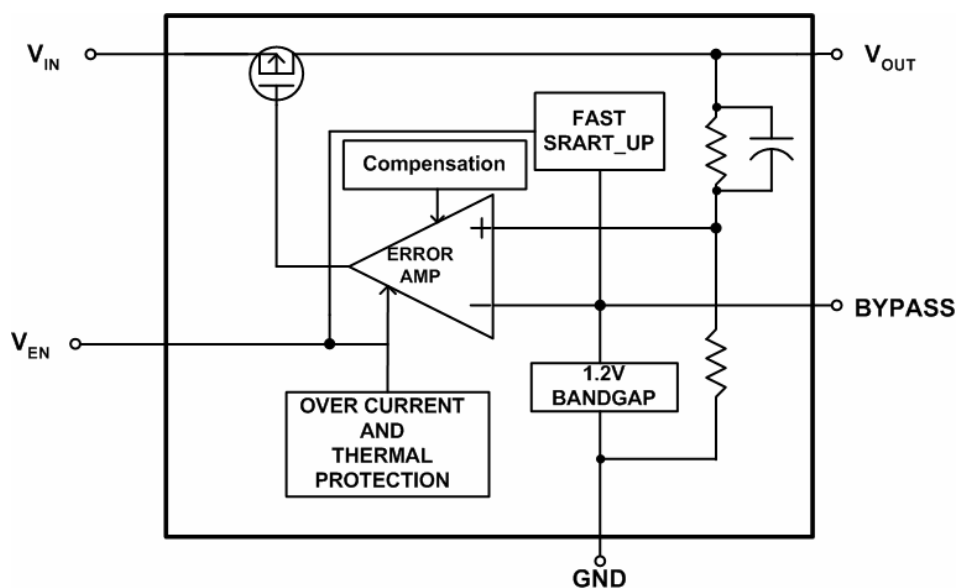

Figure 1.

Typical Application Circuit

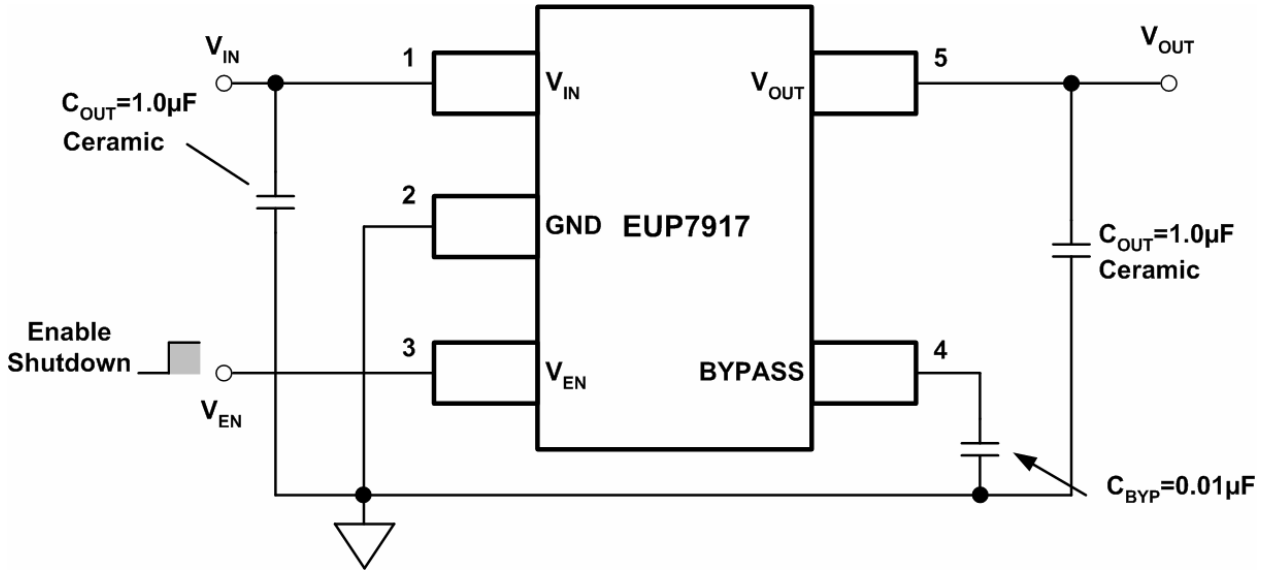

Figure 2. Fixed-Voltage LDO Regulator

Pin Configurations

Package Type	Pin Configurations
SC-70 SOT23-5	<div style="display: flex; justify-content: space-around; align-items: flex-start;"> <div style="text-align: center;"> <p>V_{EN} GND V_{IN}</p> <p>BYPASS V_{OUT}</p> <p>Fixed-Voltage</p> </div> <div style="text-align: center;"> <p>V_{EN} GND V_{IN}</p> <p>ADJ V_{OUT}</p> <p>Adjustable Voltage</p> </div> </div>

Pin Description

PIN	PIN	DESCRIPTION
V_{IN}	1	Input voltage of the LDO
GND	2	Common ground
V_{EN}	3	Enable input logic, enable high
BYPASS	4	Optional bypass capacitor for noise reduction
ADJ		Adjustable regulator feedback input. Connect to resistor divider.
V_{OUT}	5	Output voltage of the LDO

Ordering Information

Order Number	Package Type	Marking	Operating Temperature range
EUP7917-12NIR1	SC-70	pT xx	-40 °C to 125°C
EUP7917-13NIR1	SC-70	pX xx	-40 °C to 125°C
EUP7917-15NIR1	SC-70	pC xx	-40 °C to 125°C
EUP7917-18NIR1	SC-70	pD xx	-40 °C to 125°C
EUP7917-185NIR1	SC-70	pU xx	-40 °C to 125°C
EUP7917-25NIR1	SC-70	pB xx	-40 °C to 125°C
EUP7917-28NIR1	SC-70	pE xx	-40 °C to 125°C
EUP7917-285NIR1	SC-70	pF xx	-40 °C to 125°C
EUP7917-29NIR1	SC-70	pW xx	-40 °C to 125°C
EUP7917-30NIR1	SC-70	pG xx	-40 °C to 125°C
EUP7917-33NIR1	SC-70	pH xx	-40 °C to 125°C
EUP7917-35NIR1	SC-70	pR xx	-40 °C to 125°C
EUP7917-48NIR1	SC-70	pK xx	-40 °C to 125°C
EUP7917NIR1	SC-70	pA xx	-40 °C to 125°C
EUP7917-12VIR1	SOT23-5	pT xxxx	-40 °C to 125°C
EUP7917-13VIR1	SOT23-5	pX xxxx	-40 °C to 125°C
EUP7917-15VIR1	SOT23-5	pC xxxx	-40 °C to 125°C
EUP7917-18VIR1	SOT23-5	pD xxxx	-40 °C to 125°C
EUP7917-185VIR1	SOT23-5	pU xxxx	-40 °C to 125°C
EUP7917-25VIR1	SOT23-5	pB xxxx	-40 °C to 125°C
EUP7917-28VIR1	SOT23-5	pE xxxx	-40 °C to 125°C
EUP7917-285VIR1	SOT23-5	pF xxxx	-40 °C to 125°C
EUP7917-29VIR1	SOT23-5	pW xxxx	-40 °C to 125°C
EUP7917-30VIR1	SOT23-5	pG xxxx	-40 °C to 125°C
EUP7917-33VIR1	SOT23-5	pH xxxx	-40 °C to 125°C
EUP7917-35VIR1	SOT23-5	pR xxxx	-40 °C to 125°C
EUP7917-48VIR1	SOT23-5	pK xxxx	-40 °C to 125°C
EUP7917VIR1	SOT23-5	pA xxxx	-40 °C to 125°C

EUP7917-

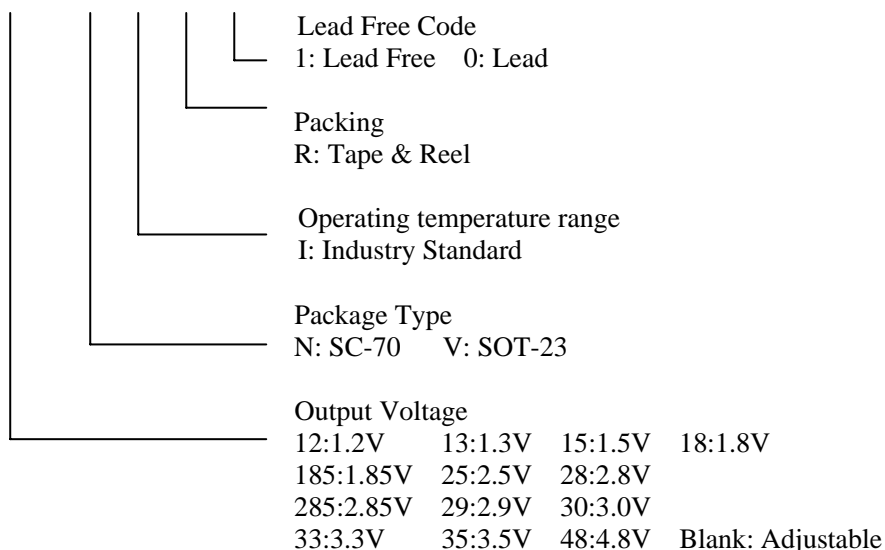

Absolute Maximum Ratings

- V_{IN}, V_{EN} ----- -0.3 to 6.5V
- V_{OUT} ----- -0.3 to ($V_{IN}+0.3$)
- Junction Temperature ----- 150°C
- Storage Temperature Range ----- -65°C to +150°C
- Lead Temperature ----- 260°C
- Thermal Resistance $\theta_{JA}(SC-70)$ ----- 330°C/W
- Thermal Resistance $\theta_{JA}(SOT23-5)$ ----- 220°C/W
- ESD Rating
Human Body Model ----- 2kV

Operating Ratings

- V_{IN} ----- 2.5 to 6V
- V_{EN} ----- 0 to ($V_{IN}+0.3$)
- Operating Temperature Range ----- -40°C to +125°C

Electrical Characteristics

Conditions: $V_{IN}=V_{OUT}+0.5V$ or 2.5V whichever is greater, $V_{EN}=V_{IN}$, $C_{IN}=1\mu F$, $C_{OUT}=1\mu F$, $T_A=-40\sim 85$
, Unless otherwise specified.

Symbol	Parameter	Conditions	EUP7917			Unit
			Min	Typ	Max.	
	Input Voltage		2.5		6	V
ΔV_{OUT}	Output Voltage Accuracy	$I_{OUT}=1mA, T_A=25$	-2		2	%
		$I_{OUT}=1mA, T_A=-40$ to 85	-3.0		3.0	
I_{OUTMAX}	Maximum Output Current	$T_A>0$	300			mA
I_{LIMIT}	Current Limit	$V_{OUT}=V_{OUT(nom)} \times 90\%, T_A>0$	300	440	800	mA
V_{DROP}	Dropout Voltage (Note1)	$V_{OUT} = 3V, I_{OUT}=80mA$		72	125	mV
		$V_{OUT} = 3V, I_{OUT}=300mA$		250	350	
		$2.4 V_{OUT} = 3V, I_{OUT}=80mA$		80	135	
		$2.4 V_{OUT} = 3V, I_{OUT}=300mA$		300	400	
I_Q	Quiescent Current	$I_{OUT}=0.05mA$		70	160	μA
		$V_{IN}=V_{OUT} (nom)-0.1V, I_{OUT}=0mA$		110	250	
V_{LNR}	Line Regulation	$V_{IN}=(V_{OUT}+0.5V)$ to 6V, $I_{OUT}=0.1mA$		0.02	0.25	%/V
V_{LDR}	Load Regulation	$1mA \leq I_{OUT} \leq 300mA$		0.002	0.013	%/mA
I_{SHDN}	Shutdown Supply Current	$V_{EN}=0, T_A=25$		0.01	1	μA
		$V_{EN}=0, T_A=85$		0.05		
PSRR	Power Supply Ripple Rejection	$V_{IN}=(V_{OUT}+1V)DC+0.5V_{P-P}$ $f=1kHz, I_{LOAD}=10mA$		75		dB
		$V_{IN}=(V_{OUT}+1V)DC+0.5V_{P-P}$ $f=10kHz, I_{LOAD}=10mA$		60		
		$V_{IN}=(V_{OUT}+1V)DC+0.5V_{P-P}$ $f=100kHz, I_{LOAD}=10mA$		45		
	Output Noise Voltage (RMS)	$f=10Hz\sim 100kHz,$ $I_{LOAD}=10mA$	Fixed-Voltage	50		μV
			Adjustable Voltage	239		
	Turn-on Time (Note2)	$R_{LOAD}=50\Omega, T_A=25$			200	μs

Electrical Characteristics (continued)

Conditions: $V_{IN}=V_{OUT}+0.5V$ or $2.5V$ whichever is greater, $V_{EN}=V_{IN}$, $C_{IN}=1\mu F$, $C_{OUT}=1\mu F$, $T_A=-40\sim 85$, Unless otherwise specified.

V_{ENL}	VENL (Maximum Low Level Input Voltage at EN)	$V_{IN}=2.5V$ to $5.5V$			0.4	V
V_{ENH}	VENH (Minimum high Level Input Voltage at EN)	$V_{IN}=2.5V$ to $5.5V$	1.5			V
	VEN Input Bias Current	$V_{IN}=5.5V$, $V_{EN}=0$ or $5.5V$		1		nA
	FB Input Bias Current (ADJ Version)	$V_{IN}=5.5V$, $V_{FB}=1.3V$		1		nA
V_{FB}	FB Pin Voltage (ADJ Version)	$T_A=25$	1.176	1.2	1.224	V
T_{SD}	Thermal Shutdown Temperature			155		
ΔT_{SD}	Thermal Shutdown Hysteresis			15		

Note 1: Dropout is defined as $V_{IN}-V_{OUT}$ when V_{OUT} is 100mV below the value of V_{OUT} for $V_{IN}=V_{OUT}+0.5V$

Note 2: Test time needed for V_{OUT} to reach 90% of final value.

四海恒通科技
www.gofotech.com

Typical Operating Characteristics

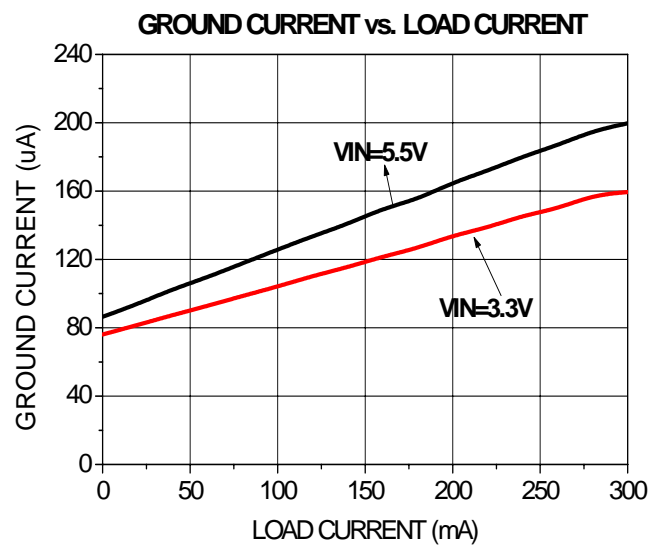
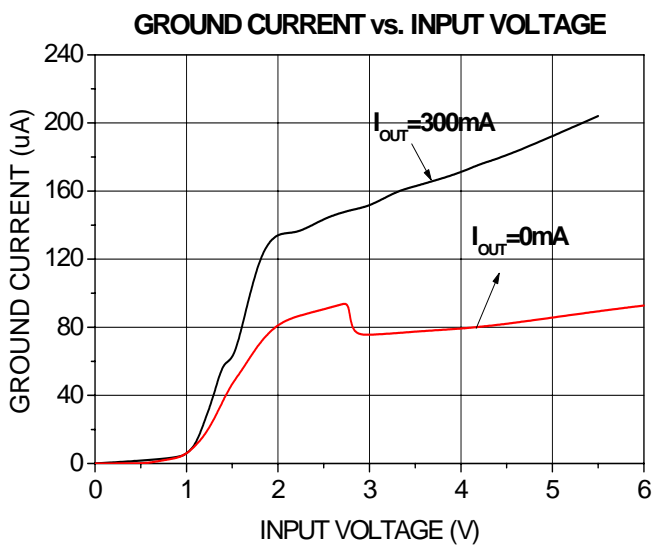
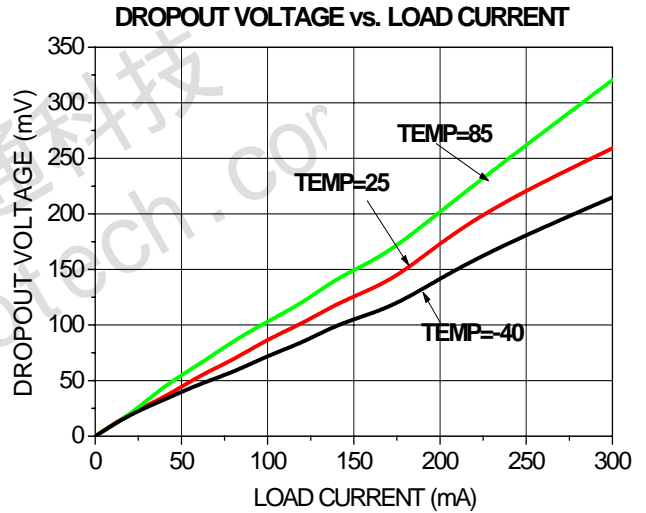
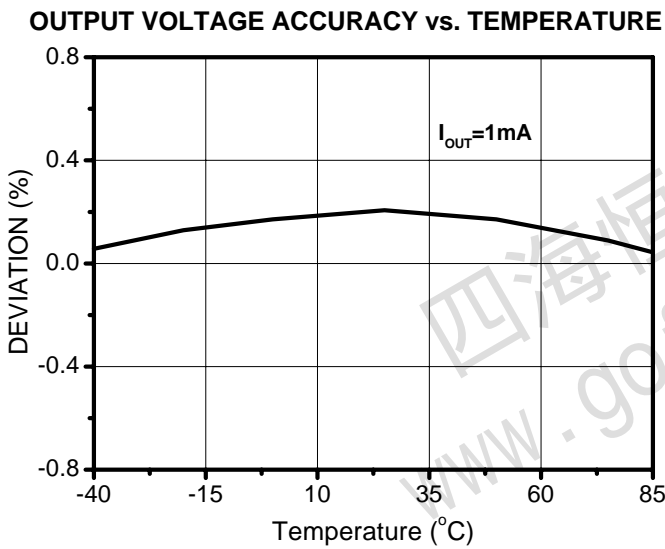
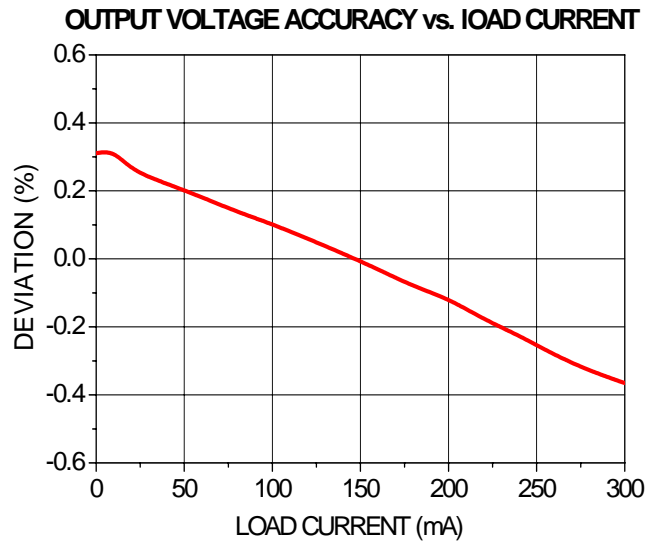
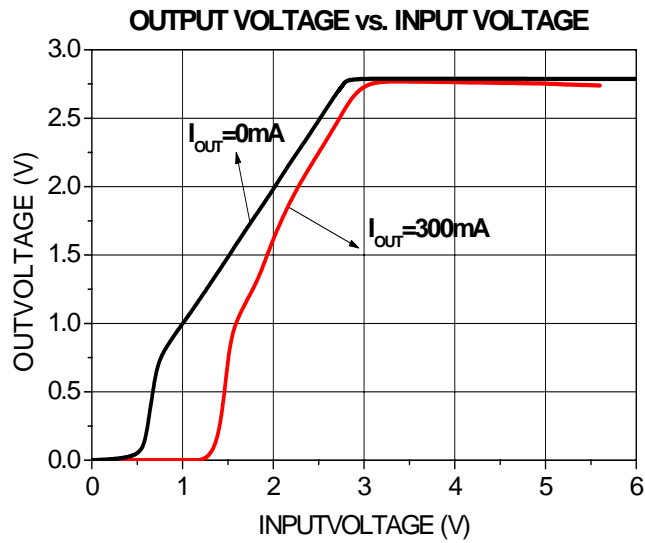

GROUND CURRENT vs. TEMPERATURE

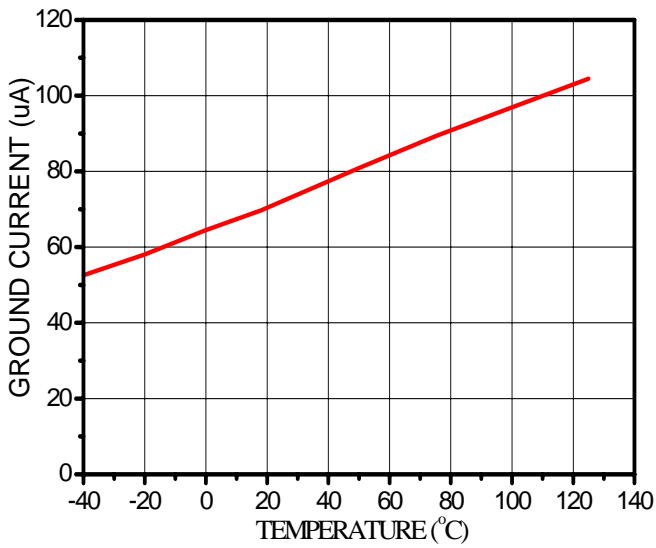

PSRR

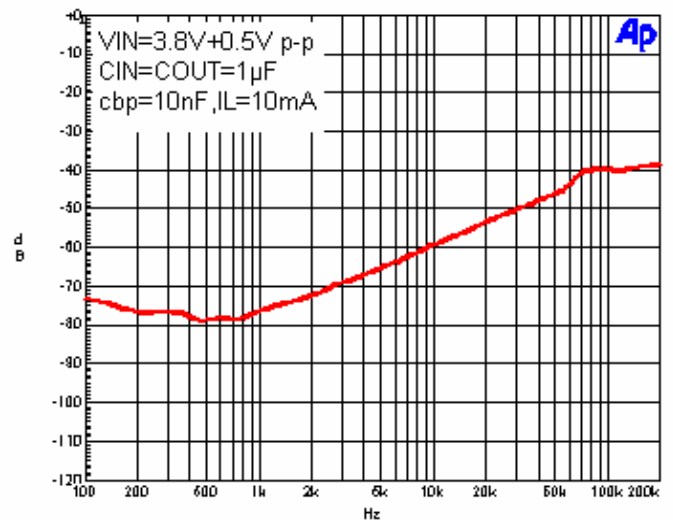

NOISE

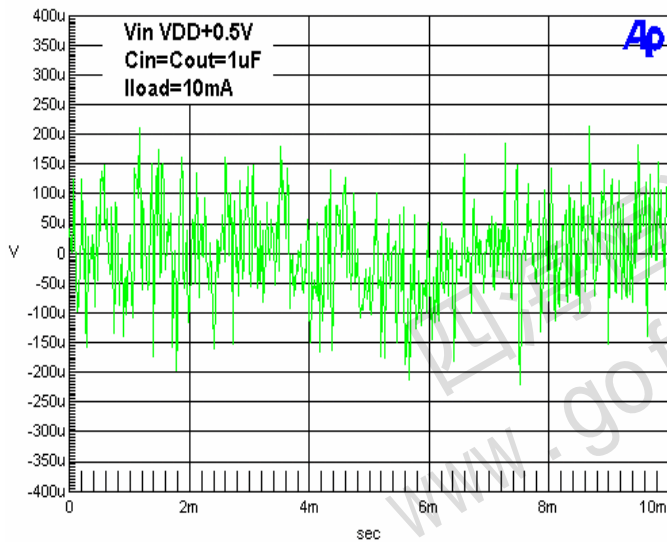

LOAD TRANSIENT RESPONSE

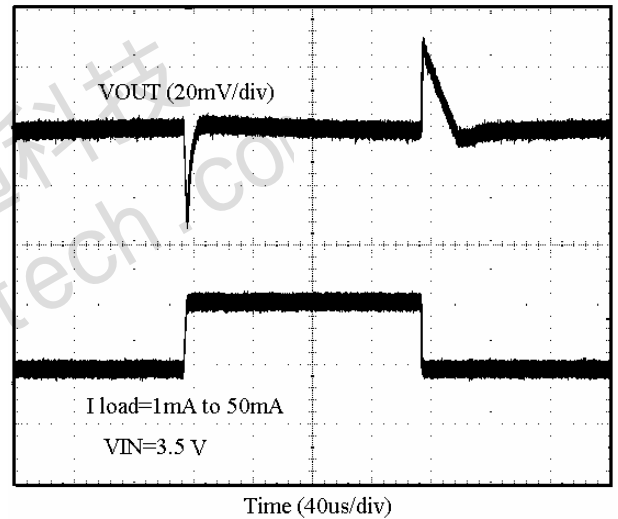

LOAD TRANSIENT RESPONSE NEAR DROPOUT

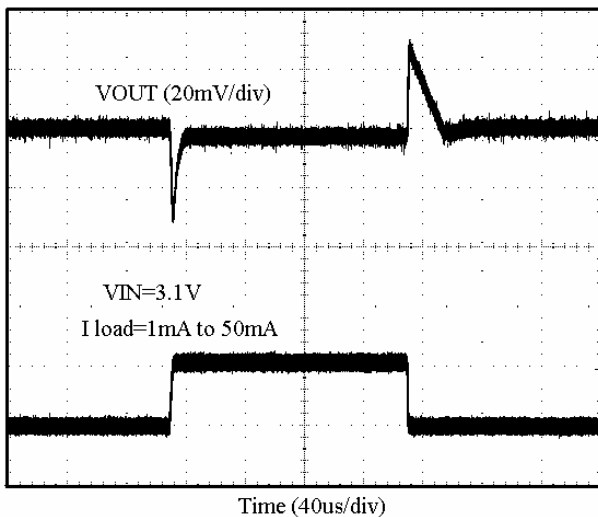

LOAD TRANSIENT RESPONSE

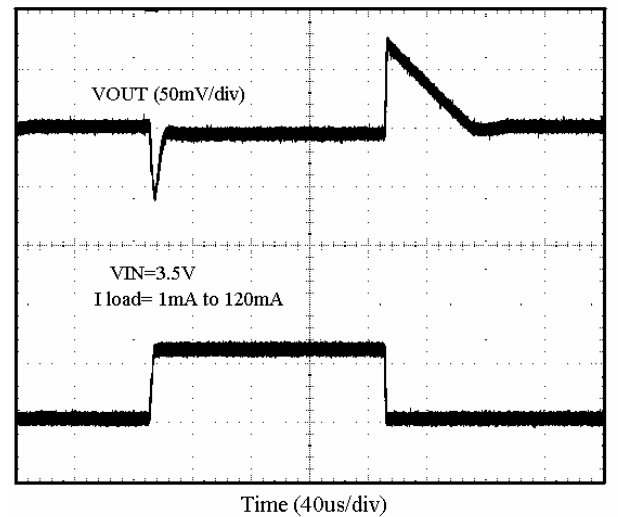

LINE TRANSIENT RESPONSE

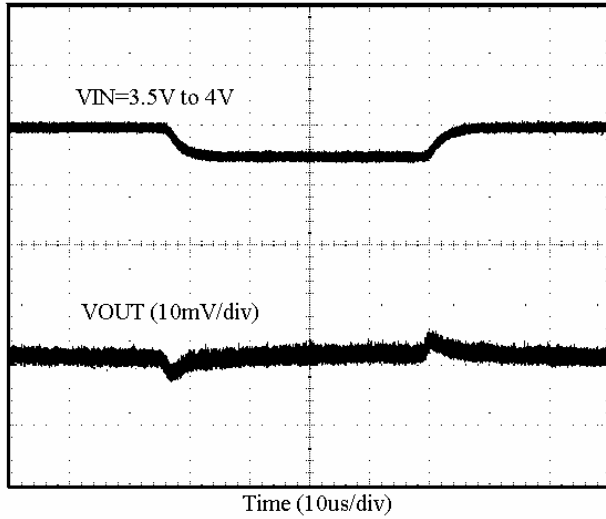

EXITING SHUTDOWN WAVEFORM

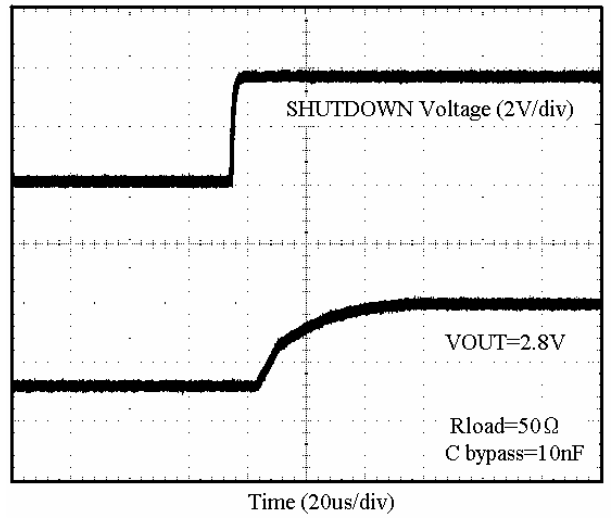

ENTERING SHUTDOWN WAVEFORM

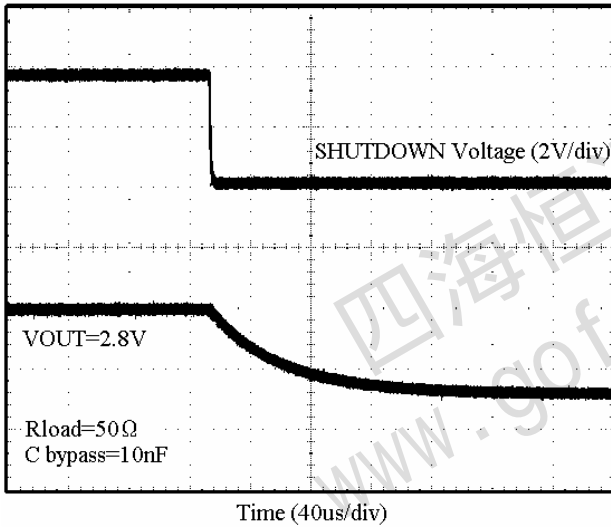

SHUTDOWN RESPONSE WAVEFORM
(CBP=100nF)

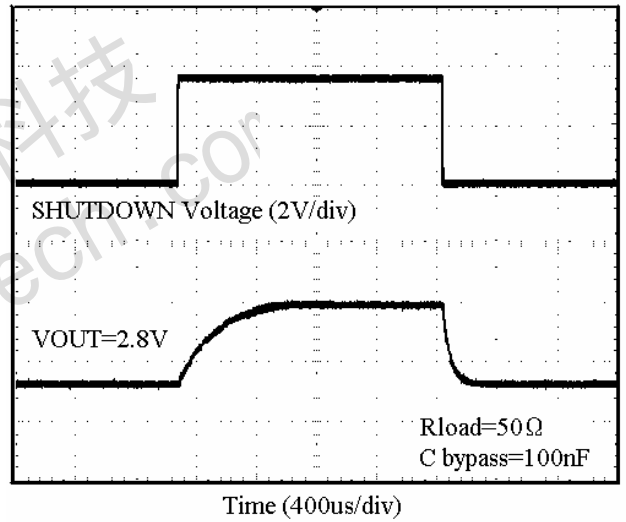

Application Note

External Capacitors

Like any low-dropout regulator, the EUP7917 requires external capacitors for regulator stability. The EUP7917 is specifically designed for portable applications requiring minimum board space and smallest components. These capacitors must be correctly selected for good performance.

Input Capacitor

An input capacitance of 1μF is required between the EUP7917 input pin and ground (the amount of the capacitance may be increased without limit).

This capacitor must be located a distance of not more than 1cm from the input pin and returned to a clean analog ground. Any good quality ceramic, tantalum, or film capacitor may be used at the input.

If a tantalum capacitor is used at the input, it must be guaranteed by the manufacturer to have a surge current rating sufficient for the application.

There are no requirements for the ESR on the input capacitor, but tolerance and temperature coefficient must be considered when selecting the capacitor to ensure the capacitance will be 1μF over the entire operating temperature range.

Output Capacitor

The EUP7917 is designed specifically to work with very small ceramic output capacitors. A ceramic capacitor (temperature characteristics X7R, X5R, Z5U, or Y5V) in 1 to 22μF range with 5mΩ to 500mΩ ESR range is suitable in the EUP7917 application circuit.

The output capacitor must meet the requirement for minimum amount of capacitance and also have an ESR (Equivalent Series Resistance) value which is within a stable range (5mΩ to 500mΩ).

No-Load Stability

The EUP7917 will remain stable and in regulation with no external load. This is specially important in CMOS RAM keep-alive applications.

Capacitor Characteristics

The EUP7917 is designed to work with ceramic capacitors on the output to take advantage of the benefits they offer: for capacitance values in the range of 1μF to 4.7μF range, ceramic capacitors are the smallest, least expensive and have the lowest ESR values (which makes them best for eliminating high frequency noise). The ESR of a typical 1μF ceramic capacitor is in the range of 20mΩ to 40mΩ, which easily meets the ESR requirement for stability by the EUP7917.

The ceramic capacitor's capacitance can vary with temperature. The capacitor type X7R, which operates over a temperature range of -55°C to +125°C, will only vary the capacitance to within ±15%. Most large value ceramic capacitors (≈2.2μF) are manufactured with Z5U or Y5V temperature characteristics. Their

capacitance can drop by more than 50% as the temperature goes from 25°C to 85°C. Therefore, X7R is recommended over Z5U and Y5V in applications where the ambient temperature will change significantly above or below 25°C.

Noise Bypass Capacitor

Connecting a 0.01μF capacitor between the C_{BYPASS} pin and ground significantly reduces noise on the regulator output. This cap is connected directly to a high impedance node in the bandgap reference circuit. Any significant loading on this node will cause a change on the regulated output voltage. For this reason, DC leakage current through this pin must be kept as low as possible for best output voltage accuracy. The types of capacitors best suited for the noise bypass capacitor are ceramic and film.

Unlike many other LDO's, addition of a noise reduction capacitor does not effect the load transient response of the device.

Adjustable Operation

The adjustable version of the EUP7917 has an output voltage range of 1.2V to 4.5V. The output voltage of the EUP7917 adjustable regulator is programmed using an external resistor divider as shown in Figure3. The output voltage is calculated using:

$$V_O = V_{ref} \times \left(1 + \frac{R_1}{R_2}\right)$$

Where:

V_{ref}= 1.2V typ. (the internal reference voltage)

Utilize the following equation for adjusting the output to a particular voltage:

$$R_1 = R_2 \left[\frac{V_O}{1.2V} - 1 \right]$$

Choose R₂=50k to optimize accuracy, power supply rejection, noise and power consumption.

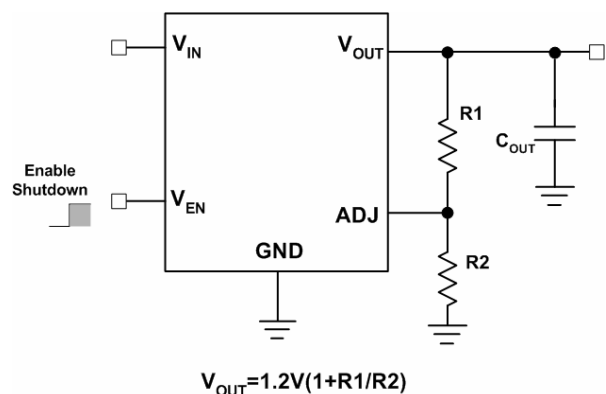

Figure3. Adjustable Regulator with Resistors

On/Off Input Operation

The EUP7917 is turned off by pulling the V_{EN} pin low, and turned on by pulling it high. If this feature is not used, the V_{EN} pin should be tied to V_{IN} to keep the regulator output on at all time. To assure proper operation, the signal source used to drive the V_{EN} input must be able to swing above and below the specified turn-on/off voltage thresholds listed in the Electrical Characteristics section under V_{IL} and V_{IH} .

Fast Start up

The EUP7917 output starts up after V_{ref} voltage reaches its final value (1.2V nominal). The start-up time is determined by the time constant of the bypass capacitor. The smaller the capacitor value, the shorter the start-up time, but less noise gets reduced. As a result, start-up time and noise reduction need to be taken into design consideration when choosing the value of the bypass capacitor.

Thermal Considerations

Thermal protection limits power dissipation in EUP7917. When the operation junction temperature exceeds 155°C, the OTP circuit starts the thermal shutdown function turn the pass element off. The pass element turn on again after the junction temperature cools by 15°C. For continue operation, do not exceed absolute maximum operation junction temperature 125°C. The power dissipation definition in device is :

$$P_D = (V_{IN} - V_{OUT}) \times I_{OUT} + V_{IN} \times I_Q$$

The maximum power dissipation depends on the thermal resistance of IC package, PCB layout, the rate of surroundings airflow and temperature difference between junction to ambient. The maximum power dissipation can be calculated by following formula :

$$P_{D(MAX)} = \frac{(T_{J(MAX)} - T_A)}{\theta_{JA}}$$

Where $T_{J(MAX)}$ is the maximum operation junction temperature 125°C, T_A is the ambient temperature and the θ_{JA} is the junction to ambient thermal resistance. For recommended operating conditions specification of EUP7917, where $T_{J(MAX)}$ is the maximum junction temperature of the die (125°C) and T_A is the maximum ambient temperature. The junction to ambient thermal resistance (θ_{JA} is layout dependent) only for SC-70 package is 330°C/W on standard thermal test board. The maximum power dissipation at $T_A = 25^\circ\text{C}$ can be calculated by following formula :

$$P_{D(MAX)} = (125^\circ\text{C} - 25^\circ\text{C}) / 330 = 300\text{mW (SC-70)}$$

The maximum power dissipation depends on operating ambient temperature for fixed $T_{J(MAX)}$ and thermal resistance θ_{JA} .

Packaging Information

SC-70

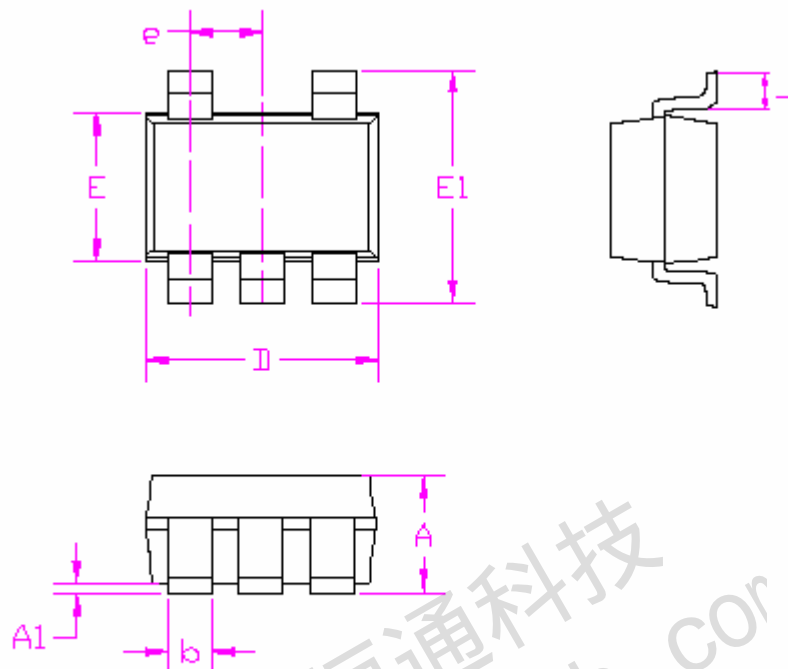

SYMBOLS	MILLIMETERS		INCHES	
	MIN.	MAX.	MIN.	MAX.
A	0.80	1.10	0.031	0.044
A1	0.025	0.10	0.001	0.004
b	0.15	0.40	0.006	0.016
D	2.00		0.079	
E	1.25		0.049	
E1	1.90	2.30	0.075	0.091
e	0.65		0.026	
L	0.21	0.46	0.008	0.018

SOT23-5

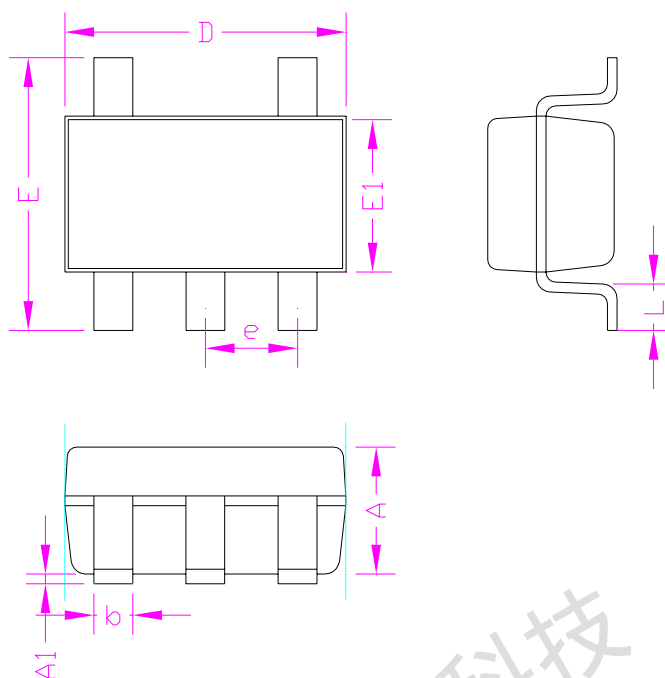

SYMBOL	MILLIMETERS		INCHES	
	MIN.	MAX.	MIN.	MAX.
A	-	1.30	-	0.052
A1	0.00	0.15	0.000	0.006
D	2.90		0.114	
E1	1.60		0.063	
E	2.60	3.00	0.102	0.118
L	0.30	0.60	0.012	0.024
b	0.30	0.50	0.012	0.020
e	0.95		0.037	