

**Low Power 12-bit 3 Gsps Digital to Analog
Converter with 4/2:1 Multiplexer
Datasheet DS1080**



MAIN FEATURES

- 12-bit Resolution
- 3 Gsps Guaranteed Conversion Rate
- 7 GHz Analog Output Bandwidth
- 4:1 or 2:1 integrated Parallel MUX (Selectable)
- Selectable Output Modes for performance optimization:
Return to Zero, Non Return to Zero, Narrow Return to Zero, RF
- Low Latency Time: 3.5 Clock Cycles
- 1.4 Watt Power Dissipation in MUX 4:1 Mode
- Functions
 - Selectable MUX Ratio 4:1 (Full Speed), 2:1 (Half Speed)
 - Triple Majority Voting
 - User-friendly Functions:
 - Gain Adjustment
 - Input Data Check Bit (FPGA Timing Check)
 - Setup Time and Hold Time Violation Flags (STVF, HTVF)
 - Clock Phase Shift Select for Synchronization with DSP (PSS[2:0])
 - Output Clock Division Selection (Possibility to Change the Division Ratio of the DSP Clock)
 - Input Under Clocking Mode
 - Diode for Die junction Temperature Monitoring
- LVDS Differential Data input and DSP Clock Output
- Analog Output Swing: 1V_{pp} Differential (100Ω Differential Impedance)
- External Reset for Synchronization of Multiple MuxDACs
- Power Supplies: 3.3 V (Digital), 3.3V & 5.0V (Analog)
- LGA255, CCGA255, Ci-CGA255 Package (21 × 21 mm Body Size, 1.27 mm Pitch)

PERFORMANCES

Broadband: NPR at -14 dB Loading Factor, (See [Section 7.2.7 "NPR Performance" on page 62](#))

- | | | |
|------------------------------|---------------|----------|
| • 1st Nyquist (NRTZ): | NPR = 51.3 dB | 10.0 Bit |
| Equivalent at Fs = 3 Gsps | | |
| • 1st Nyquist (NRTZ): | NPR = 55.7 dB | 10.8 Bit |
| Equivalent at Fs = 1.5 Gsps | | |
| • 2nd Nyquist (NRTZ or RTZ): | NPR = 44.6 dB | 8.9 Bit |
| Equivalent at Fs = 3 Gsps | | |
| • 3rd Nyquist (RF): | NPR = 42.5 dB | 8.6 Bit |
| Equivalent at Fs = 3 Gsps | | |

Single Tone: (see [Section 5. "Functional Description" on page 17](#))

- Performances Characterized for Fout from 100 MHz to 4500 MHz and from 2 Gsps to 3.2 Gsps
- Performance Industrially Screened Over 3 Nyquist Zones at 3 Gsps for Selected Fout.

Step Response

- Full Scale Rise /Fall Time 60 ps

APPLICATIONS

- Direct Digital Synthesis for Broadband Applications (L-S and Lower C Band)
- Automatic Test Equipment (ATE)
- Arbitrary Waveform Generators
- Radar Waveform Signal Synthesis
- DOCSIS V3.0 Systems

Whilst e2v technologies has taken care to ensure the accuracy of the information contained herein it accepts no responsibility for the consequences of any use thereof and also reserves the right to change the specification of goods without notice. e2v technologies accepts no liability beyond the set out in its standard conditions of sale in respect of infringement of third party patents arising from the use of the devices in accordance with information contained herein.

e2v technologies (uk) limited, Waterhouse Lane, Chelmsford, Essex CM1 2QU United Kingdom Holding Company: e2v technologies plc

Telephone: +44 (0)1245 493493 Facsimile: +44 (0)1245 492492

Contact e2v by e-mail: enquiries@e2v.com or visit www.e2v.com for global sales and operations centres

1. BLOCK DIAGRAM

Figure 1-1. Simplified Block Diagram

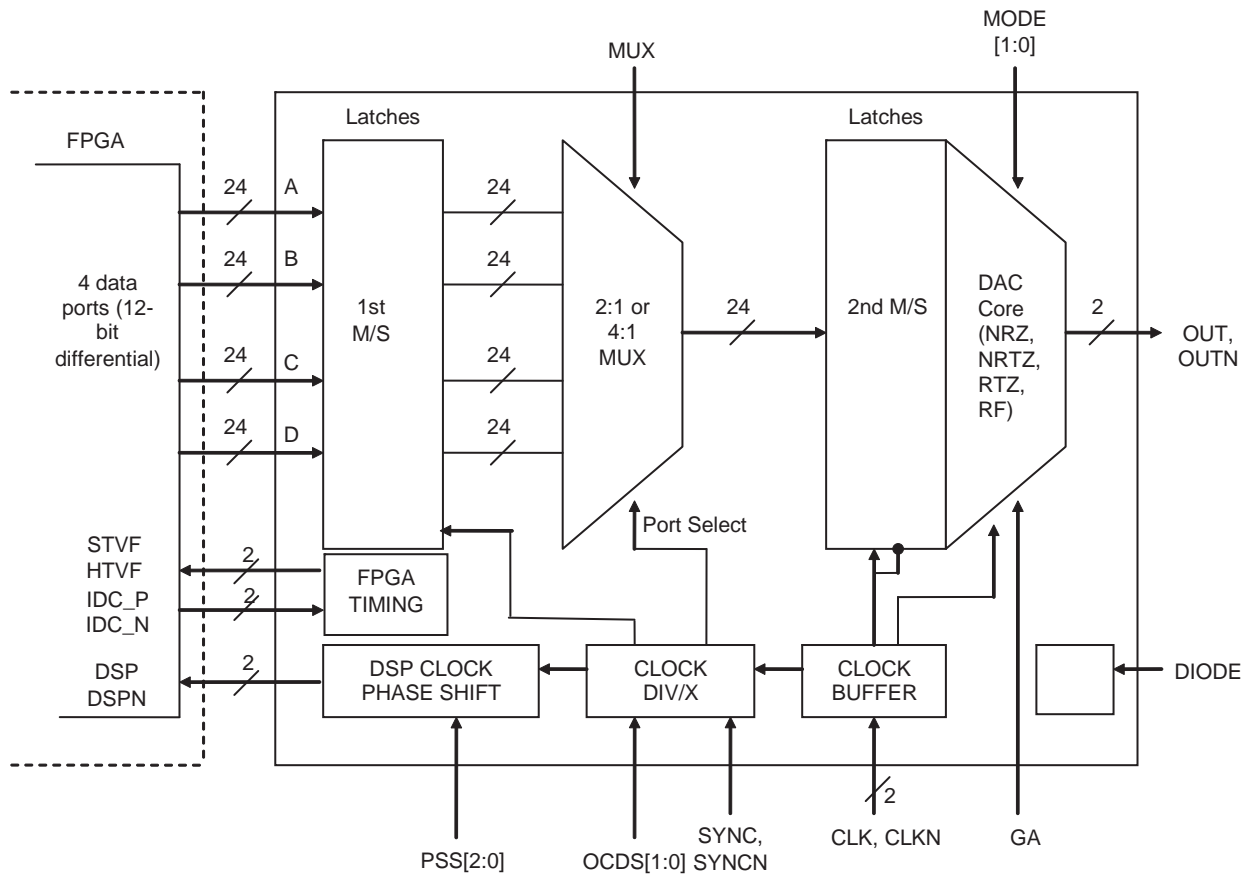

2. DESCRIPTION

The EV12DS130A/B is a 12-bit 3 Gbps DAC with an integrated 4:1 or 2:1 multiplexer, allowing easy interface with standard LVDS FPGAs thanks to user friendly features as OCDS, PSS.

It embeds different output modes (RTZ, NRZ, narrow RTZ, RF) that allow performance optimizations depending on the working Nyquist zone.

The Noise Power Ratio (NPR) performance, over more than 900 MHz instantaneous bandwidth, and the high linearity (SFDR, IMD) over full 1st Nyquist zone at 3 Gbps (NRZ feature), make this product well suited for high-end applications such as arbitrary waveform generators and broadband DDS systems.

3. ELECTRICAL CHARACTERISTICS

3.1 Absolute Maximum Ratings

Table 3-1. Absolute Maximum Ratings

Parameter	Symbol	Value	Unit
Positive Analog supply voltage	V_{CCA5}	6.0	V
Positive Analog supply voltage	V_{CCA3}	4.0	V
Positive Digital supply voltage	V_{CCD}	4.0	V
Digital inputs (on each single-ended input) and IDC, SYNC, signal Port P = A, B, C, D V_{IL} V_{IH} Digital Input maximum Differential mode swing	[P0..P11], [PON.. P11N] IDC_P, IDC_N SYNC, SYNCN	GND-0.3 V_{CCA3} 2.0	V V V_{pp}
Master clock input (on each single-ended input) V_{IL} V_{IH} Master Clock Maximum Differential mode swing	CLK, CLKN	1.5 3.5 2.5	V V V_{pp}
Control functions inputs V_{IL} V_{IH}	MUX, MODE[0..1], PSS[0..2], OCDS[0..1]	-0.4V $V_{CCD} + 0.4$	V V
Gain Adjustment function	GA	-0.3V, $V_{CCA3} + 0.3$	V
Maximum Junction Temperature	T_j	170	°C
Storage Temperature	T_{stg}	-65 to 150	°C
Electrostatic discharge immunity ESD Classification	ESD HBM	1000 Class 1B	V

- Notes:
1. Absolute maximum ratings are limiting values (referenced to GND = 0V), to be applied individually, while other parameters are within specified operating conditions. Long exposure to maximum rating may affect device reliability.
 2. All integrated circuits have to be handled with appropriate care to avoid damages due to ESD. Damage caused by inappropriate handling or storage could range from performance degradation to complete failure.
 3. Maximum ratings enable active inputs with DAC powered off.
 4. Maximum ratings enable floating inputs with DAC powered on.
 5. DSP clock and STVF, HTVF output buffers must not be shorted to ground nor positive power supply.

3.2 Recommended Conditions of Use

Table 3-2. Recommended Conditions of Use

Parameter	Symbol	Comments	Recommended Value	Unit	Note
Positive analog supply voltage	V_{CCA5}		5.0	V	(2)(4)
Positive analog supply voltage	V_{CCA3}		3.3	V	(1)(2)(4)
Positive digital supply voltage	V_{CCD}		3.3	V	(2)(4)
Digital inputs (on each single-ended input) and IDC, SYNC, signal Port P = A, B, C, D V_{IL} V_{IH} Differential mode swing	[P0..P11], [PON.. P11N] IDC_P, IDC_N SYNC, SYNCN		1.075 1.425 700	V V mV _{pp}	(3)
Master clock input power level (Differential mode)	P_{CLK}		3	dBm	(3)
Control functions inputs	MUX, OCDS, PSS, MODE, PSS	V_{IL} V_{IH}	0 V_{CCD}	V V	
Gain Adjustment function	GA	Range	0 V_{CCA3}	V	
Operating Temperature Range	$T_c = T_{case}$ $T_j = T_{junction}$	Military "M" & space grade	$-55^{\circ}\text{C} < T_c, T_j < 125^{\circ}\text{C}$	$^{\circ}\text{C}$	

- Notes:
1. For low temperature it is recommended to operate at maximum analog supplies (V_{CCA3}) level.
 2. The rise time of any power supplies (V_{ccd} , V_{cca5} , V_{cca3}) shall be <10ms.
For EV12DS130A, in order to obtain the guaranteed performances and functionality, the following rules shall be followed when powering the devices (See [Section 8.9 "Power Up Sequencing" on page 75](#))
For EV12DS130B, no specific power up sequence nor power supplies relationships are required.
 3. Analog output is in differential. Single-ended operation is not recommended. Guaranteed performance is only in differential configuration.
 4. No power-down sequencing is required.

3.3 Electrical Characteristics

Values in the tables below are based on our conditions of measurement and valid over temperature range respectively for M, and Space quality level and for typical power supplies ($V_{CCA5} = 5.0V$, $V_{CCA3} = 3.3V$, $V_{CCD} = 3.3V$), typical swing, unless specified and in MUX4:1 mode.

Table 3-3. Electrical Characteristics

Parameter	Symbol	Min	Typ	Max	Unit	Note	Test Level ⁽²⁾
RESOLUTION		12			bit		1,6
POWER REQUIREMENTS							
Power Supply voltage							
- Analog	V_{CCA5}	4.75	5	5.25	V	(7)(8)	1,6
- Analog	V_{CCA3}	3.15	3.3	3.45	V		
- Digital	V_{CCD}	3.15	3.3	3.45	V		
Power Supply current (4:1 MUX)							
- Analog	I_{CCA5}		84	92	mA		1,6
- Analog	I_{CCA3}		106	125	mA		
- Digital	I_{CCD}		187	213	mA		
Power Supply current (2:1 MUX)							
- Analog	I_{CCA5}		84	92	mA		1,6
- Analog	I_{CCA3}		106	125	mA		
- Digital	I_{CCD}		160	185	mA		
Power dissipation (4:1 MUX)	P_D		1.4	1.6	W		1,6
Power dissipation (2:1 DMUX)	P_D		1.3	1.5	W		1,6
DIGITAL DATA INPUTS, SYNC and IDC INPUTS							
Logic compatibility		LVDS					
Digital input voltages:							
- Differential input voltage	V_{ID}	100	350	500	mV _p		1,6
- Common mode	V_{ICM}		1.25		V		4
Input capacitance from each single input to ground				2	pF		5
Differential Input resistance		80	100	120	Ω		1,6
CLOCK INPUTS							
Input voltages (Differential operation swing)		0.56	1	2.24	V_{pp}		4
Power level (Differential operation)		-4	1	8	dBm	(1)	4
Common mode		2.4	2.5	2.6	V		4
Input capacitance from each single input to ground (at die level)			2		pF		5
Differential Input resistance		80	100	120	Ω		1,6

Table 3-3. Electrical Characteristics (Continued)

Parameter	Symbol	Min	Typ	Max	Unit	Note	Test Level ⁽²⁾
DSP CLOCK OUTPUT							
Logic compatibility		LVDS					
Digital output voltages:							
- Differential output voltage	V_{OD}	240	350	450	mV _p		1,6
- Common mode	V_{OCM}		1.30		V		4
ANALOG OUTPUT							
Full-scale Differential output voltage (100Ω differentially terminated)		0.92	1	1.08	V _{pp}		1,6
Full-scale output power (differential output)		0.25	1	1.64	dBm		1,6
Single-ended mid-scale output voltage (50Ω terminated)			$V_{CCA5} - 0.43$		V	(4)	
Output capacitance			1.5		pF		5
Output internal differential resistance		90	100	110	Ω		1, 6
Output VSWR (using e2v evaluation board)							
1.5 GHz			1.17				4
3 GHz			1.54				
4.5 GHz			1.64				
Output bandwidth			6		GHz		4
FUNCTIONS							
Digital functions: MODE, OCDS, PSS, MUX							
- Logic 0	V_{IL}		0	0.8	V		
- Logic 1	V_{IH}	1.6	V_{CCD}		V		
- Input Current	I_{IN}			150	μA	(6)	
Gain Adjustment function	GA	0	0				1,6
			V_{CCA3}				
Digital output function (HTVF, STVF)							
- Logic 0	V_{OL}	-	-	0.8	V	(5)	
- Logic 1	V_{OH}	2.1	-		V		1,6
- Output Current	I_O			80	μA	(6)	
DC ACCURACY							
Differential Non-Linearity	DNL+			0.95	LSB		1,6
Differential Non-Linearity	DNL-	-0.95			LSB		1,6
Integral Non-Linearity	INL+			3	LSB		1,6
Integral Non-Linearity	INL-	-3			LSB		1,6
DC gain:							
- Initial gain error		-8	0	+8	%		1,6
- DC gain adjustment			±11		%	(3)	4
- DC gain sensitivity to power supplies				+6	%		1,6
- DC gain drift over temperature			±2		%		4

Notes: 1. For use in higher Nyquist zone, it is recommended to use higher power clock within the limit.

2. See [Section 3.6 on page 14](#) for explanation of test levels.
3. Initial gain error corresponds to the deviation of the DC gain center value from unity gain. The DC gain adjustment (GA function) ensures that the initial gain deviation can be cancelled.
The DC gain sensitivity to power supplies is given according the rule:
 $\text{GainSensVsSupply} = |\text{Gain@VccMin} - \text{Gain@VccMax}| / \text{Gain@Vccnom}$
4. Single-ended operation is not recommended, this line is given for better understanding of what is output by the DAC.
5. In order to modify the V_{OL}/V_{OH} value, potential divider could be used.
6. Sink or source.
7. Only for EV12DS130A dependency between power supplies:
Within the applicable power supplies range, the following relationship shall always be satisfied $V_{CCA3} \geq V_{CCD}$, taking into account AGND and DGND planes are merged and power supplies accuracy.
8. Please refer [Section 8.9 "Power Up Sequencing" on page 75](#).

3.4 AC Electrical Characteristics

Values in the tables below are based on our conditions of measurement and valid over temperature range respectively for M, and Space quality level and for typical power supplies ($V_{CCA5} = 5.0V$, $V_{CCA3} = 3.3V$, $V_{CCD} = 3.3V$), typical swing, unless specified and in MUX4:1 mode.

Table 3-4. AC Electrical Characteristics NRZ Mode (First Nyquist Zone)

Parameter	Symbol	Min	Typ	Max	Unit	Note	Test level ⁽¹⁾
Single-tone Spurious Free Dynamic Range First Nyquist Fs = 3 GSps @ Fout = 100 MHz 0 dBFS Fs = 3 GSps @ Fout = 400 MHz 0 dBFS Fs = 3 GSps @ Fout = 100 MHz -3 dBFS	SFDR	57	68 63		dBc		1,6 4 1,6
Highest spur level First Nyquist Fs = 3 GSps @ Fout = 100 MHz 0 dBFS Fs = 3 GSps @ Fout = 400 MHz 0 dBFS Fs = 3 GSps @ Fout = 100 MHz -3 dBFS			-68 -61 -72	-56 -60	dBm		1,6 4 1,6
SFDR sensitivity & high spur level variation over power supplies			±2		dB		4
Signal independent Spur (clock-related spur) Fc/2 Fc/4			-82 -85		dBm dBm		4 4
Noise Power Ratio -14 dBFS peak to rms loading factor Fs = 3 GSps 20 MHz to 900 MHz broadband pattern, 25 MHz notch centered on 450 MHz	NPR	45	49		dB	(2)	1,6

Table 3-4. AC Electrical Characteristics NRZ Mode (First Nyquist Zone) (Continued)

Parameter	Symbol	Min	Typ	Max	Unit	Note	Test level ⁽¹⁾
Equivalent ENOB Computed from NPR figure at 3 GSps	ENOB	9	9.6		Bit	(2)	1,6
Signal to Noise Ratio Computed from NPR figure at 3 GSps	SNR	56	58		dB	(2)	1,6
DAC self noise density at code 0 or 4095			-163	-154	dBm/H z		1,6

Notes: 1. See [Section 3.6 on page 14](#) for explanation of test levels.

2. Figures in tables are derived from industrial screening; for practical reasons (necessity to cover also 2nd and 3rd Nyquist Zones) the balun used for industrial test is not optimum for first Nyquist performances, and results when Fout or folded low order harmonics are between DC to 400 MHz are very pessimistic. For further details please refer to [Section 7.2 on page 42](#) for effect of the balun on performances.

Table 3-5. AC Electrical Characteristics NRTZ Mode (First & Second Nyquist Zone)

Parameter	Symbol	Min	Typ	Max	Unit	Note	Test level ⁽¹⁾
Single-tone Spurious Free Dynamic Range MUX4:1 Fs = 3 GSps @ Fout = 100 MHz 0 dBFS Fs = 3 GSps @ Fout = 700 MHz 0 dBFS Fs = 3 GSps @ Fout = 1800 MHz 0 dBFS	SFDR	60	68		dBc		1,6
Fs = 3 GSps @ Fout = 700 MHz 0 dBFS		55	62				1,6
Fs = 3 GSps @ Fout = 1800 MHz 0 dBFS		52	61				1,6
Fs = 3 GSps @ Fout = 700 MHz -3 dBFS		57	66				1,6
MUX2:1 Fs = 1.5 GSps @ Fout = 700 MHz 0 dBFS		51	65				1,6
Highest spur level MUX4:1 Fs = 3 GSps @ Fout = 100 MHz 0 dBFS Fs = 3 GSps @ Fout = 700 MHz 0 dBFS Fs = 3 GSps @ Fout = 1800 MHz 0 dBFS			-70	-62	dBm		1,6
Fs = 3 GSps @ Fout = 700 MHz 0 dBFS			-64	-56			1,6
Fs = 3 GSps @ Fout = 1800 MHz 0 dBFS			-67	-57			1,6
Fs = 3 GSps @ Fout = 700 MHz -3 dBFS			-70	-62			1,6
MUX2:1 Fs = 1.5 GSps @ Fout = 700 MHz 0 dBFS			-68	-53			1,6
SFDR sensitivity & high spur level variation over power supplies			±2		dB		4

Table 3-5. AC Electrical Characteristics NRTZ Mode (First & Second Nyquist Zone) (Continued)

Parameter	Symbol	Min	Typ	Max	Unit	Note	Test level ⁽¹⁾
Signal independent Spur (clock-related spur)							
Fc			-29		dBm		4
Fc/2			-80		dBm		4
Fc/4			-80		dBm		4
DAC self noise density at code 0 or 4095			-149	-143	dBm/Hz		1,6
Noise Power Ratio -14 dBFS peak to rms loading factor Fs = 3 GSps 20 MHz to 900 MHz broadband pattern, 25 MHz notch centered on 450 MHz	NPR	45.5	50.2		dB	(2)	1,6
Equivalent ENOB Computed from NPR figure at 3 GSps	ENOB	9.1	9.9		Bit	(2)	1,6
Signal to Noise Ratio Computed from NPR figure at 3 GSps	SNR	56.5	61.2		dB	(2)	1,6
Noise Power Ratio -14 dBFS peak to rms loading factor Fs = 1.5 GSps 10 MHz to 450 MHz broadband pattern, 12.5 MHz notch centered on 225 MHz	NPR		55.7		dB	(2)	4
Equivalent ENOB Computed from NPR figure at 1.5 GSps	ENOB		10.8		Bit	(2)	4
Signal to Noise Ratio Computed from NPR figure at 1.5 GSps	SNR		66.7		dB	(2)	4

- Notes:
1. See [Section 3.6 on page 14](#) for explanation of test levels.
 2. Figures in tables are derived from industrial screening; for practical reasons (necessity to cover also 2nd and 3rd Nyquist Zones) the balun used for industrial test is not optimum for first Nyquist performances, and results when Fout or folded low order harmonics are between DC to 400 MHz are very pessimistic. For further details please refer to [Section 7.2 on page 42](#) for effect of the balun on performances.

Table 3-6. AC Electrical Characteristics RTZ Mode (Second Nyquist Zone)⁽²⁾

Parameter	Symbol	Min	Typ	Max	Unit	Note	Test level ⁽¹⁾
Single-tone Spurious Free Dynamic Range MUX4:1 Fs = 3 GSps @ Fout = 1600 MHz 0 dBFS Fs = 3 GSps @ Fout = 2900 MHz 0 dBFS	SFDR	49	60 57		dBc		4 1,6
Highest spur level MUX4:1 Fs = 3 GSps @ Fout =1600 MHz 0 dBFS Fs = 3 GSps @ Fout = 2900 MHz 0 dBFS			-67 -66	-59	dBm		4 1,6
SFDR sensitivity & high spur level variation over power supplies			±2		dB		4
Signal independent Spur (clock-related spur)							
Fc			-25		dBm		4
Fc/2			-80		dBm		4
Fc/4			-80		dBm		4
DAC self noise density at code 0 or 4095			-143	-139	dBm/Hz		1,6
Noise Power Ratio -14 dBFS peak to rms loading factor Fs = 3 GSps 1520 MHz to 2200 MHz broadband pattern, 25 MHz notch centered on 1850 MHz	NPR	39.5	44.0		dB		1,6
Equivalent ENOB Computed from NPR figure at 3 GSps	ENOB	8.1	8.8		Bit		1,6
Signal to Noise Ratio Computed from NPR figure at 3 GSps	SNR	50.5	55.0		dB		1,6

- Notes: 1. See [Section 3.6 on page 14](#) for explanation of test levels.
2. Please refer to [Section 7.2 "AC Performances" on page 42](#) to have detailed characterization results.

Table 3-7. AC Electrical Characteristics RF Mode (Second and Third Nyquist Zones)⁽²⁾

Parameter	Symbol	Min	Typ	Max	Unit	Note	Test level ⁽¹⁾
Single-tone Spurious Free Dynamic Range 2 nd Nyquist Fs = 3 GSps @ Fout = 1600 MHz 0 dBFS Fs = 3 GSps @ Fout = 2900 MHz 0 dBFS 3 rd Nyquist Fs = 3 GSps @ Fout = 3800 MHz 0 dBFS Fs = 3 GSps @ Fout = 4400 MHz 0 dBFS	SFDR	44	52 60		dBc		1,6 4 1,6 1,6
Highest spur level 2 nd Nyquist Fs = 3 GSps @ Fout = 1600 MHz 0 dBFS Fs = 3 GSps @ Fout = 2900 MHz 0 dBFS 3 rd Nyquist Fs = 3 GSps @ Fout = 3800 MHz 0 dBFS Fs = 3 GSps @ Fout = 4400 MHz 0 dBFS			-58 -58	-50	dBm		1,6 4 1,6 1,6
SFDR sensitivity & high spur level variation over power supplies			±2		dB		4
Signal independent Spur (clock-related spur) Fc Fc/2 Fc/4			-28 -80 -80		dBm dBm dBm		4 4 4
DAC self noise density at code 0 or 4095			-141	-138	dBm/Hz		1,6
Noise Power Ratio (2 nd Nyquist) -14 dBFS peak to rms loading factor Fs = 3 GSps 1520 MHz to 2200 MHz broadband pattern, 25 MHz notch centered on 1850 MHz	NPR	38	42		dB		1,6
Equivalent ENOB Computed from NPR figure at 3 GSps	ENOB	7.8	8.5		Bit		1,6
Signal to Noise Ratio Computed from NPR figure at 3 GSps	SNR	49	53		dB		1,6
Noise Power Ratio -14 dBFS peak to rms loading factor Fs = 3 GSps 2200 MHz to 2880 MHz broadband pattern, 25 MHz notch centered on 2550 MHz	NPR	38	42		dB		1,6

Table 3-7. AC Electrical Characteristics RF Mode (Second and Third Nyquist Zones)⁽²⁾ (Continued)

Parameter	Symbol	Min	Typ	Max	Unit	Note	Test level ⁽¹⁾
Equivalent ENOB Computed from NPR figure at 3 GSps	ENOB	7.8	8.5		Bit		1,6
Signal to Noise Ratio Computed from NPR figure at 3 GSps	SNR	49	53		dB		1,6
Noise Power Ratio –14 dBFS peak to rms loading factor Fs = 3 GSps 3050 MHz to 3700 MHz broadband pattern, 25 MHz notch centered on 3375 MHz	NPR	38	40		dB	(2)	1,6
Equivalent ENOB Computed from NPR figure at 3 GSps	ENOB	7.8	8.2		Bit	(2)	1,6
Signal to Noise Ratio Computed from NPR figure at 3 GSps	SNR	49	51		dB	(2)	1,6

Notes: 1. See [Section 3.6 on page 14](#) for explanation of test levels.

2. Figures in tables are derived from industrial screening without any correction to take in account the balun effect, but for practical reasons (necessity to cover also 2nd and 3rd Nyquist Zones) the balun used for industrial test is not optimum for first Nyquist performances, and results when Fout or folded low order hamonics are between DC to 400 MHz are very pessimistic.

3.5 Timing Characteristics and Switching Performances

Table 3-8. Timing Characteristics and Switching Performances

Parameter	Symbol	Min	Typ	Max	Unit	Note	Test level ⁽¹⁾
SWITCHING PERFORMANCE AND CHARACTERISTICS							
Operating clock frequency 4:1 MUX mode 2:1 MUX mode		300 300		3000 1500	MHz		4
TIMING CHARACTERISTICS							
Analog output rise/fall time	T_{OR} T_{OF}		60		ps	(2)	4
Data Tsetup (Fc = 3 Gsps)		250			ps	(3)	4
Data Thold (Fc = 3 Gsps)		100			ps	(3)	4
Max Input data rate (Mux 4:1)		75		750	MSps		4
Max Input data rate (Mux 2:1)		150		750	MSps		4
Master clock input jitter				100	fs rms	(4)	5
DSP clock phase tuning steps			0.5		Clock period		5
Master clock to DSP, DSPN delay	TDSP		1.6		ns		4

Table 3-8. Timing Characteristics and Switching Performances (Continued)

Parameter	Symbol	Min	Typ	Max	Unit	Note	Test level ⁽¹⁾
SYNC forbidden area lower bound (Fc = 3 Gsps)	T ₁		200		ps	(5)(6)	4
SYNC forbidden area upper bound (Fc = 3 Gsps)	T ₂		180		ps	(5)(6)	4
SYNC to DSP, DSPN MUX 2:1 MUX4:1			880 1600		ps		4
Data Pipeline Delay MUX4:1 MUX2:1	TPD		3.5 3.5		Clock period		4
Data Output Delay	TOD		160		ps		4

- Notes:
1. See [Section 3.6 on page 14](#) for explanation of the test level.
 2. Analog output rise/fall time measured from 20% to 80% of a full scale jump, after probe de-embedding.
 3. Exclusive of period (pp) jitter on Data. Setup and hold time for DATA at input relative to DSP clock at output of the component, at PSS = 000; also applicable for IDC signal.
 4. Master clock input jitter defined over 5 GHz bandwidth.
 5. T_c represents the master clock period. See [Figure 3-3](#).
 6. For EV12DS130A, please refer to erratasheet 1125

Figure 3-1. Timing Diagram for 4:1 MUX Principle of Operation OCDS[00]

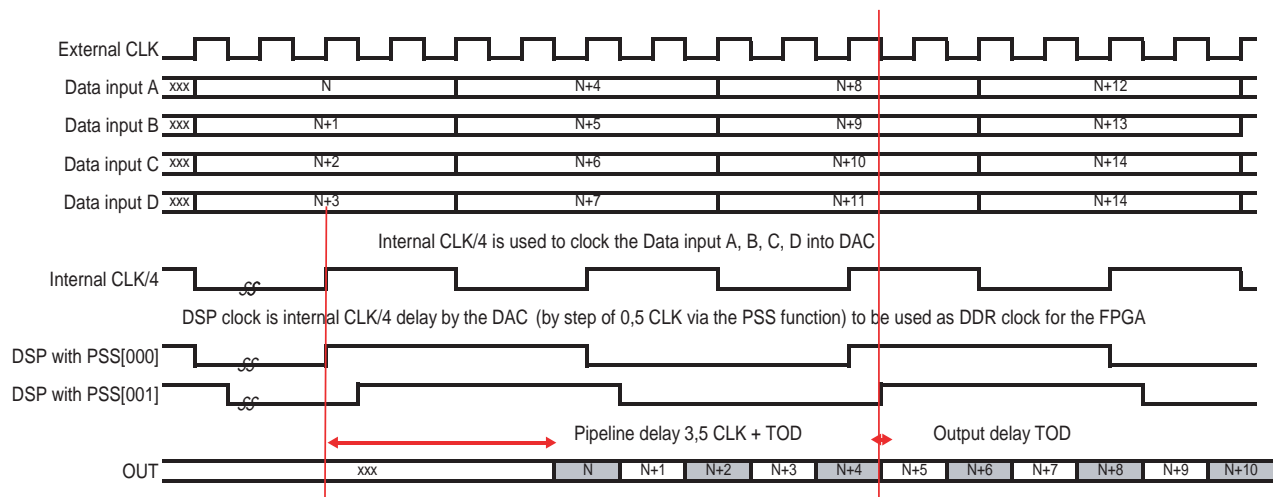

Figure 3-2. Timing Diagram for 2:1 MUX Principle of Operation OCDS[00]

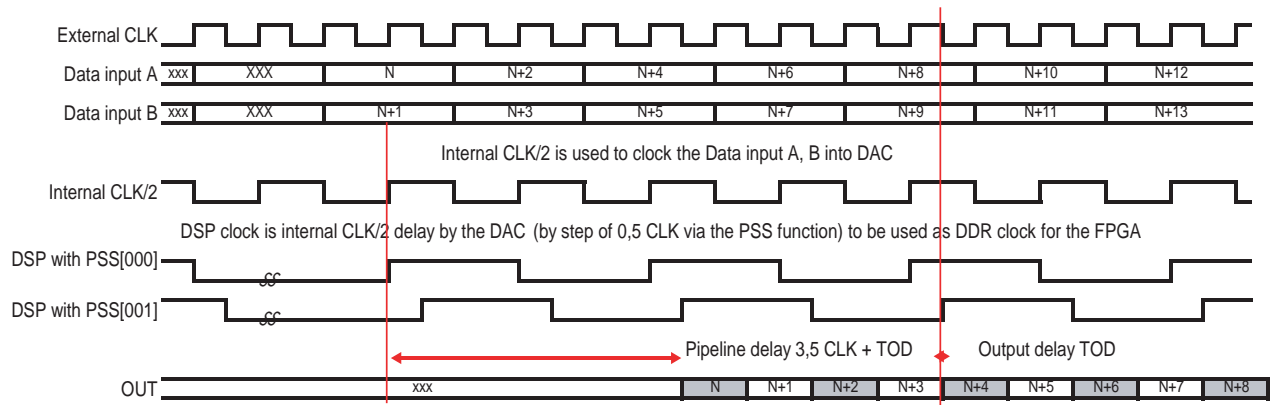
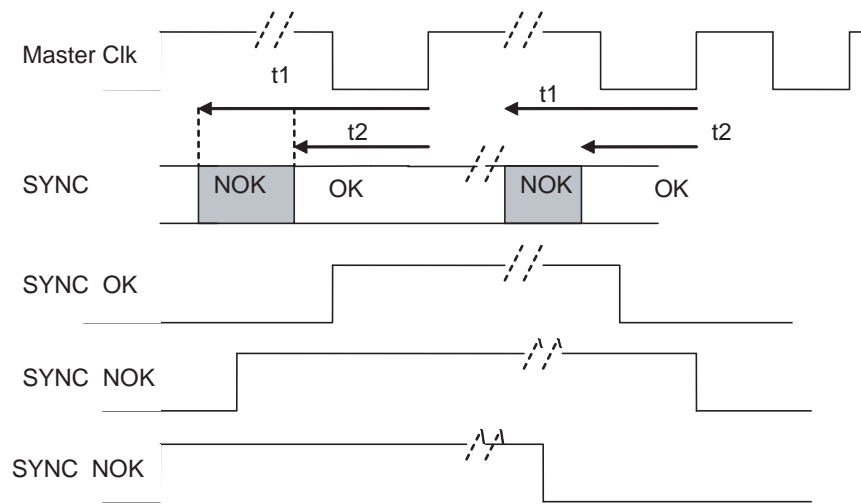

Figure 3-3. SYNC Timing Diagram



Please refer to [Section 5.9 "Synchronization functions for multi-DAC operation"](#) on page 31.

3.6 Explanation of Test Levels

1	100% production tested at +25°C ⁽¹⁾
2	100% production tested at +25°C ⁽¹⁾ , and sample tested at specified temperatures.
3	Sample tested only at specified temperatures
4	Parameter is guaranteed by design and/or characterization testing (thermal steady-state conditions at specified temperature)
5	Parameter value is guaranteed by design
6	100% production tested over specified temperature range (for Space/Mil grade ⁽²⁾)

Only MIN and MAX values are guaranteed.

- Notes:
1. Unless otherwise specified.
 2. If applicable, please refer to "Ordering Information"

3.7 Digital Input Coding Table

Table 3-9. Coding Table (Theoretical values)

Digital output msb.....lsb	Differential analog output
000000000000	-500 mV
010000000000	-250 mV
011000000000	-125 mV
011111111111	-0.122 mV
100000000000	0.122 mV
101000000000	+125 mV
110000000000	+250 mV
111111111111	+500 mV

4. DEFINITION OF TERMS

Abbreviation	Term	Definition
(Fs max)	<i>Maximum conversion Frequency</i>	Maximum conversion frequency
(Fs min)	<i>Minimum conversion frequency</i>	Minimum conversion Frequency
(SFDR)	<i>Spurious free dynamic range</i>	Ratio expressed in dB of the RMS signal amplitude, set at Full Scale, to the RMS value of the highest spectral component (peak spurious spectral component). The peak spurious component may or may not be a harmonic. It may be reported in dB (i.e., related to converter 0 dB Full Scale), or in dBc (i.e, related to input signal level).
(HSL)	<i>High Spur Level</i>	Power of highest spurious spectral component expressed in dBm.
(ENOB)	<i>Effective Number Of Bits</i>	ENOB is determined from NPR measurement with the formula: $\text{ENOB} = (\text{NPR}_{[\text{dB}]} + \text{ILF}_{[\text{dB}]} - 3 - 1.76) / 6.02$ Where LF "Loading factor" is the ratio between the Gaussian noise standard deviation versus amplitude full scale.
(SNR)	<i>Signal to noise ratio</i>	SNR is determined from NPR measurement with the formula: $\text{SNR}_{[\text{dB}]} = \text{NPR}_{[\text{dB}]} + \text{ILF}_{[\text{dB}]} - 3$ Where LF "Loading factor" is the ratio between the Gaussian noise standard deviation versus amplitude full scale.
(DNL)	<i>Differential non linearity</i>	The Differential Non Linearity for an given code i is the difference between the measured step size of code i and the ideal LSB step size. DNL (i) is expressed in LSBs. DNL is the maximum value of all DNL (i). DNL error specification of less than 1 LSB guarantees that there are no missing point and that the transfer function is monotonic.
(INL)	<i>Integral non linearity</i>	The Integral Non Linearity for a given code i is the difference between the measured voltage at which the transition occurs and the ideal value of this transition. INL (i) is expressed in LSBs, and is the maximum value of all INL (i)
(TPD/TOD)	<i>Output delay</i>	The analog output propagation delay measured between the rising edge of the differential CLK, CLKN clock input (zero crossing point) and the zero crossing point of a full-scale analog output voltage step. TPD corresponds to the pipeline delay plus an internal propagation delay (TOD) including package access propagation delay and internal (on-chip) delays such as clock input buffers and DAC conversion time.
(NPR)	<i>Noise Power Ratio</i>	The NPR is measured to characterize the DAC performance in response to broad bandwidth signals. When applying a notch-filtered broadband white-noise pattern at the input to the DAC under test, the Noise Power Ratio is defined as the ratio of the average noise measured on the shoulder of the notch and inside the notch on the same integration bandwidth.
(VSWR)	<i>Voltage Standing Wave Ratio</i>	The VSWR corresponds to the insertion loss linked to power reflection. For example a VSWR of 1:2 corresponds to a 20dB return loss (ie. 99% power transmitted and 1% reflected).
(IUCM)	<i>Input under clocking mode</i>	The IUCM principle is to apply a selectable division ratio between DAC section clock and the MUX section clock.
(PSS)	<i>Phase Shift Select</i>	The Phase Shift Select function allow to tune the phase of the DSPclock.
(OCDS)	<i>Output Clock Division Selectt</i>	It allows to divide the DSPclock frequency by the OCDS coded value factor
(NRZ)	<i>Non Return to Zero mode</i>	Non Return to Zero mode on analog output
(RF)	<i>Radio Frequency mode</i>	RF mode on analog output
(RTZ)	<i>Return to zero</i>	Return to zero mode on analog output
(NRTZ)	<i>Narrow return to zero</i>	Narrow return to zero mode on analog output

5. FUNCTIONAL DESCRIPTION

Figure 5-1. DAC Functional Diagram

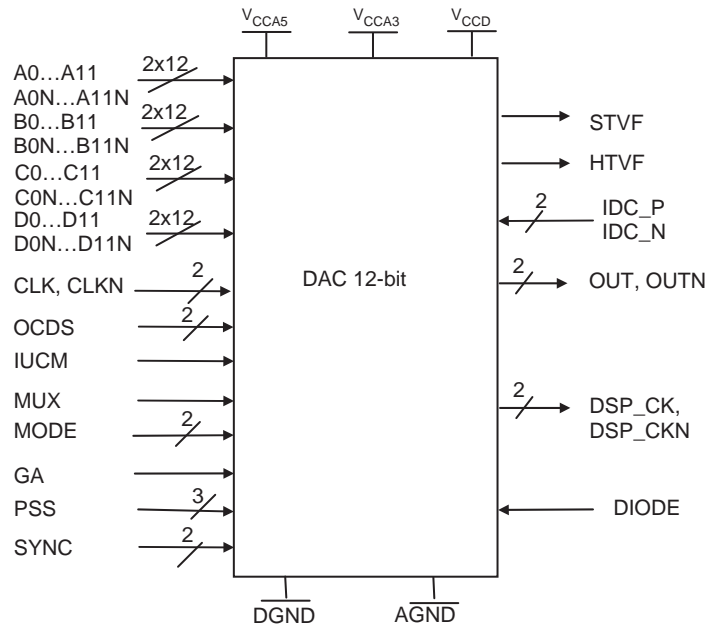

Table 5-1. Functions Description

Name	Function	Name	Function
V _{CCD}	3.3V Digital Power Supply	CLK	In-phase Master clock
V _{CCA5}	5.0V Analog Power Supply	CLKN	Inverted phase Master clock
V _{CCA3}	3.3V Analog Power Supply	DSP_CK	In-phase Output clock
DGND	Digital Ground	DSP_CKN	Inverted phase Output clock
AGND	Analog ground (for analog supply reference)	PSS[0..2]	Phase shift select
A[11..0]	In-phase digital input Port A	GA	Gain Adjust
A[11..0]N	Inverted phase digital input Port A	MUX	Multiplexer Selection
B[11..0]	In-phase digital input Port B	MODE[0..1]	DAC Mode: NRZ, RTZ, NRTZ, RF
B[11..0]N	Inverted phase digital input Port B	STVF	Setup time Violation flag
C[11..0]	In-phase digital input Port C	HTVF	Hold time Violation flag
C[11..0]N	Inverted phase digital input Port C	IDC_P, IDC_N	Input data check
D[11..0]	In-phase digital input Port D	OCDS[0..1]	Output Clock Division factor Selection
D[11..0]N	Inverted phase digital input Port D	Diode	Diode for temperature monitoring
OUT	In-phase analog output	SYNC/SYCN	Synchronization signal (Active High)
OUTN	Inverted phase analog output	IUCM	Input UnderClocking Mode

5.1 DSP Output Clock

The DSP output clock DSP, DSPN is an LVDS signal which is used to synchronize the FPGA generating the digital patterns with the DAC sampling clock.

The DSP clock frequency is a fraction of the sampling clock frequency. The division factor depends on OCDS settings. The DSP clock frequency is equal to (sampling frequency / [2N*X]) where N is the MUX ratio and X is the output clock division factor, determined by OCDS[0..1] bits.

For example, in a 4:1 MUX ratio application with a sampling clock of 3 GHz and OCDS set to "00" (ie. Factor of 1), the input data rate is 750 MSps and the DSP clock frequency is 375 MHz.

This DSP clock is used in the FPGA to control the digital data sequencing. Its phase can be adjusted using the PSS[2:0] bits (refer to [Section 5.5 on page 26](#)) in order to ensure a proper synchronization between the data coming to the DAC and the sampling clock.

The HTVF and STVF bits should be used to check whether the timing between the FPGA and the DAC is correct. HTVF and STVF bits will indicate whether the DAC and FPGA are aligned or not. PSS bits should then be used to shift the DSP clock and thus the input data of the DAC, so that a correct timing is achieved between the FPGA and the DAC.

Important note: Maximum supported sampling frequency when using DSP to clock digital data is 2.1 Gbps on EV12DS130B. Please refer to application note AN1141 to use EV12DS130B at sampling frequency beyond 2.1 GHz.

5.2 Multiplexer

Two multiplexer ratio are allowed:

- 4:1 which allows operation at full sampling rate (ie. 3 GHz)
- 2:1 which can only be used up to 1.5 GHz sampling rate, except in IUCM mode

Label	Value	Description
MUX	0	4:1 mode
	1	2:1 mode

In 2:1 MUX ratio, the unused data ports (ports C and D) can be left open.

5.3 MODE Function

Label	Value	Description	Default Setting (Not Connected)
MODE[1:0]	00	NRZ mode	11 RF mode
	01	Narrow RTZ (a.k.a. NRTZ) mode	
	10	RTZ Mode (50%)	
	11	RF mode	

The MODE function allows choosing between NRZ, NRTZ, RTZ and RF functions. NRZ and narrow RTZ should be chosen for use in 1st Nyquist zone while RTZ should be chosen for use in 2nd and RF for 3rd Nyquist zones.

Theory of operation: see following subsections for time domain waveform of the different modes.

Ideal equations describing max available Pout for frequency domain in the four modes are given hereafter, with X = normalized output frequency (that is Fout/Fclock, edges of Nyquist zones are then at X = 0 1/2 1 3/2 2 ...). Due to limited bandwidth, an extra term must be added to take in account a first order low pass filter.

NRZ mode:

$$P_{out}(X) = 20 \cdot \log_{10} \cdot \left[\frac{|k \cdot \text{sinc}(k \cdot \pi \cdot X)|}{0.893} \right]$$

where sinc(x) = sin(x)/x, and k = 1

NRTZ mode:

$$P_{out}(X) = 20 \cdot \log_{10} \cdot \left[\frac{|k \cdot \text{sinc}(k \cdot \pi \cdot X)|}{0.893} \right] \quad k = \frac{T_{clk} - T_{\tau}}{T_{clk}}$$

where T_τ is width of reshaping pulse, T_τ is about 75ps.

RTZ mode:

$$P_{out}(X) = 20 \cdot \log_{10} \cdot \left[\frac{|k \cdot \text{sinc}(k \cdot \pi \cdot X)|}{0.893} \right]$$

where k is the duty cycle of the clock presented at the DAC input, please note that due to phase mismatch in balun used to convert single ended clock to differential clock the first zero may move around the limit of the 4th and the 5th Nyquist zones. Ideally k = 1/2.

RF mode:

$$P_{out}(X) = 20 \cdot \log_{10} \cdot \left[\frac{\left| k \cdot \text{sinc}\left(\frac{k \cdot \pi \cdot X}{2}\right) \cdot \sin\left(\frac{k \cdot \pi \cdot X}{2}\right) \right|}{0.893} \right]$$

where k is as per in NRTZ mode.

As a consequence:

- NRZ mode offers max power for 1st Nyquist operation
- RTZ mode offers slow roll off for 2nd Nyquist or 3rd Nyquist operation
- RF mode offers maximum power over 2nd and 3rd Nyquist operation
- NRTZ mode offers optimum power over full 1st and first half of 2nd Nyquist zones. This is the most relevant in term of performance for operation over 1st and beginning of 2nd Nyquist zone. Depending on the sampling rate the zero of transmission moves in the 3rd Nyquist zone from begin to end when sampling rate increases.

Note in the two following figures: Pink line is ideal equation's result, and green line includes a first order 6 GHz cut-off low pass filter to take into account finite bandwidth effect due to die and package.

Figure 5-2. Max Available Pout[dBm] at Nominal Gain vs Fout[GHz] in the Four Output Modes at 3 Gsps, over four Nyquist Zones, Computed for $\tau = 75$ ps

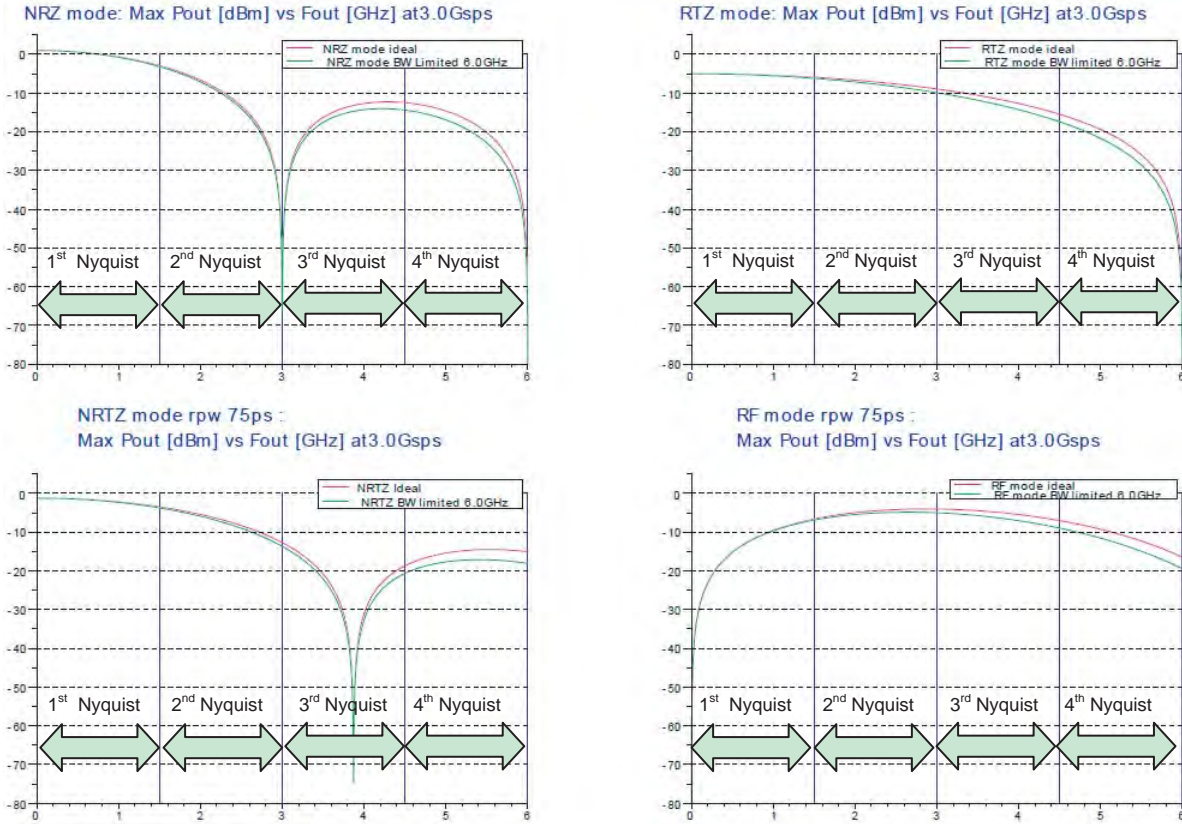
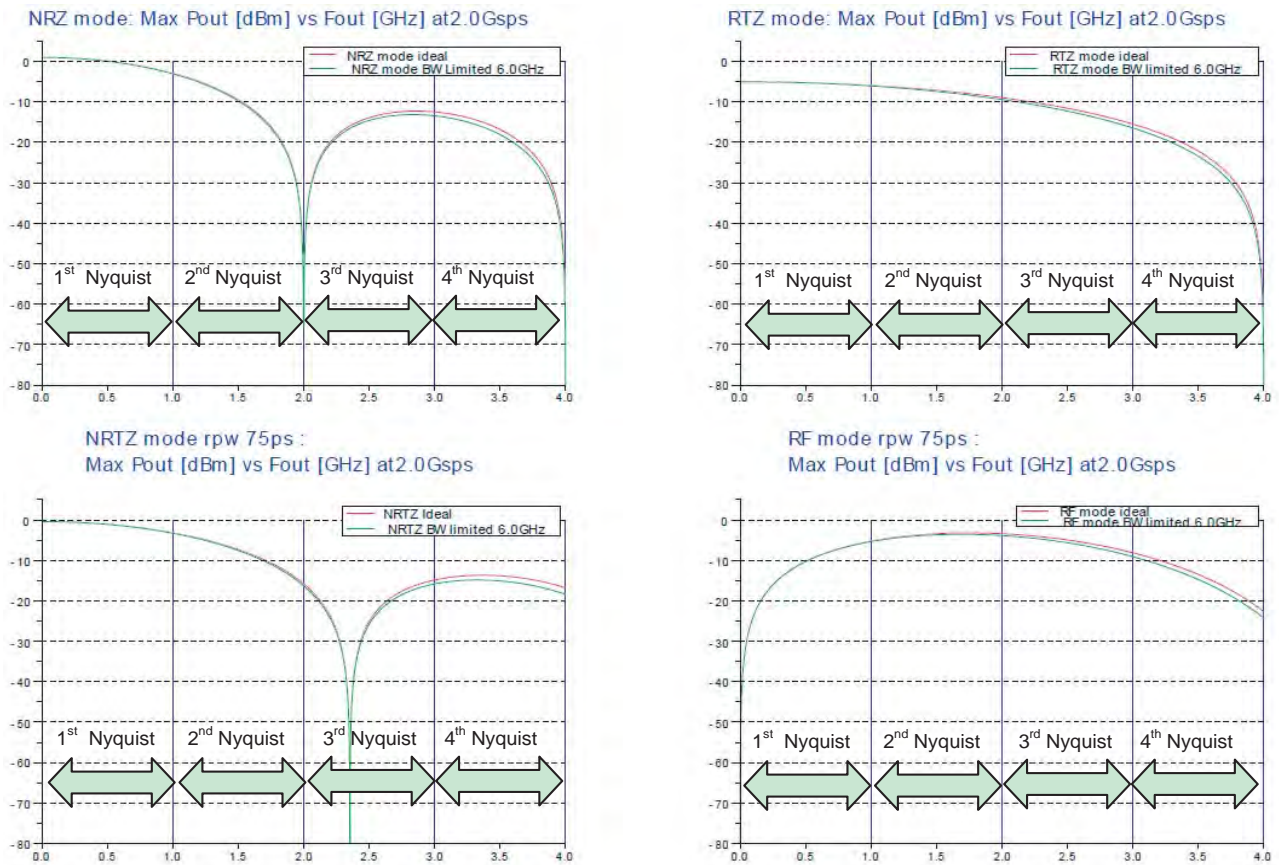

Figure 5-3. Max available Pout[dBm] at Nominal Gain vs Fout[GHz] in the Four Output Modes at 2 Gsps, over four Nyquist Zones, Computed for $T\tau = 75$ ps



5.3.1 NRZ Output Mode

This mode does not allow for operation in the 2nd Nyquist zone because of the Sinx/x notch.

The advantage is that it gives good results at the beginning of the 1st Nyquist zone (less attenuation than in RTZ architecture), it removes the parasitic spur at the clock frequency (in differential).

Figure 5-4. NRZ Timing Diagram

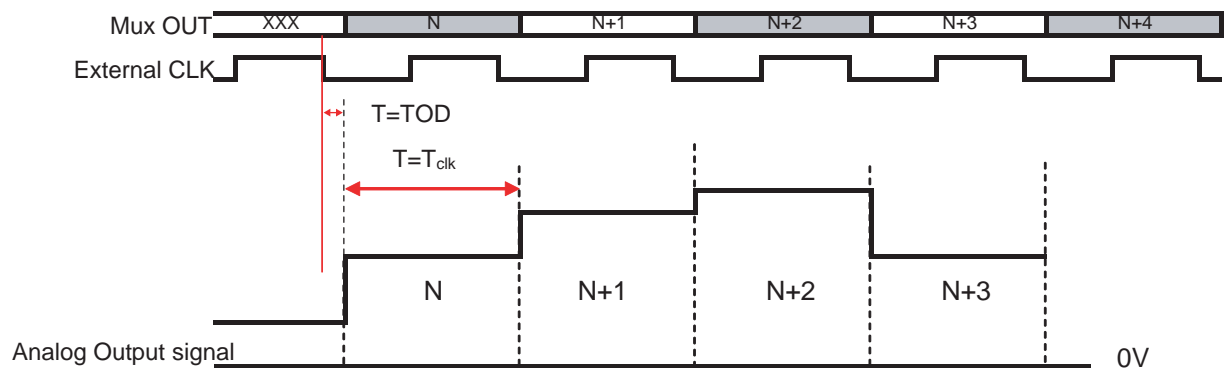

5.3.2 Narrow RTZ Mode (NRTZ Mode)

This mode has the following advantages:

- Optimized power in 1st Nyquist zone
- Extended dynamic through elimination of noise on transition edges
- Improved spectral purity (see [Section 7.2.3 on page 50](#))
- Trade off between NRZ and RTZ

Figure 5-5. Narrow RTZ Timing Diagram

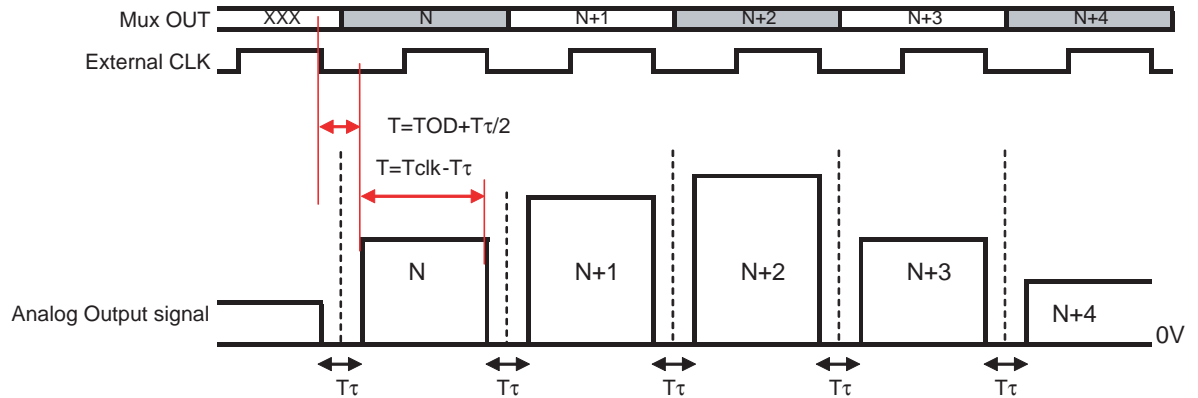

Note: T_{τ} is independent of F_{clock} .

5.3.3 RTZ Mode

The advantage of the RTZ mode is to enable the operation in the 2nd zone but the drawback is clearly to attenuate more the signal in the first Nyquist zone.

Advantages:

- Extended roll off of sinc
- Extended dynamic through elimination of hazardous transitions

Weakness:

- By construction clock spur at F_s .

Figure 5-6. RTZ Timing Diagram

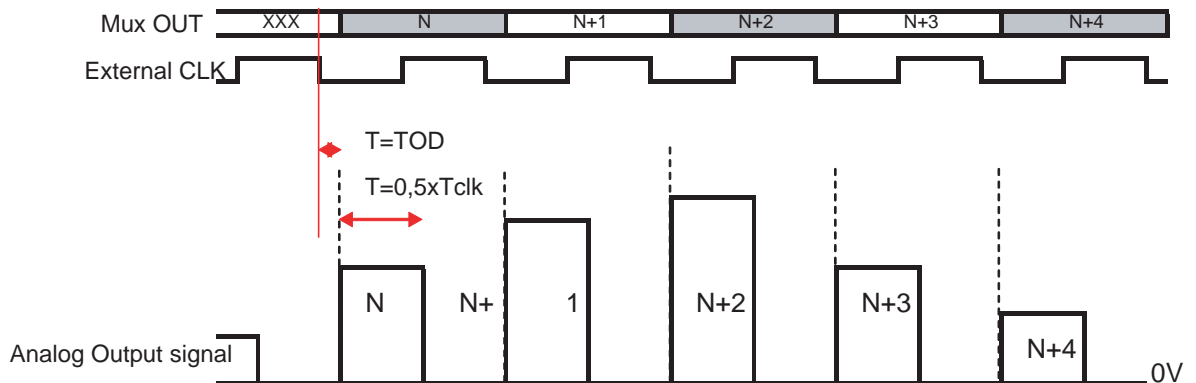

5.3.4 RF Mode

RF mode is optimal for operation at high output frequency, since the decay with frequency occurs at higher frequency than for RTZ. Unlike NRZ or RTZ modes, RF mode presents a notch at DC and $2N \cdot F_s$, and minimum attenuation for $F_{out} = F_s$.

Advantages:

- Optimized for 2nd and 3rd Nyquist operation
- Extended dynamic range through elimination of hazardous transitions.
- Clock spur pushed to $2 \cdot F_s$

Figure 5-7. RF Timing Diagram

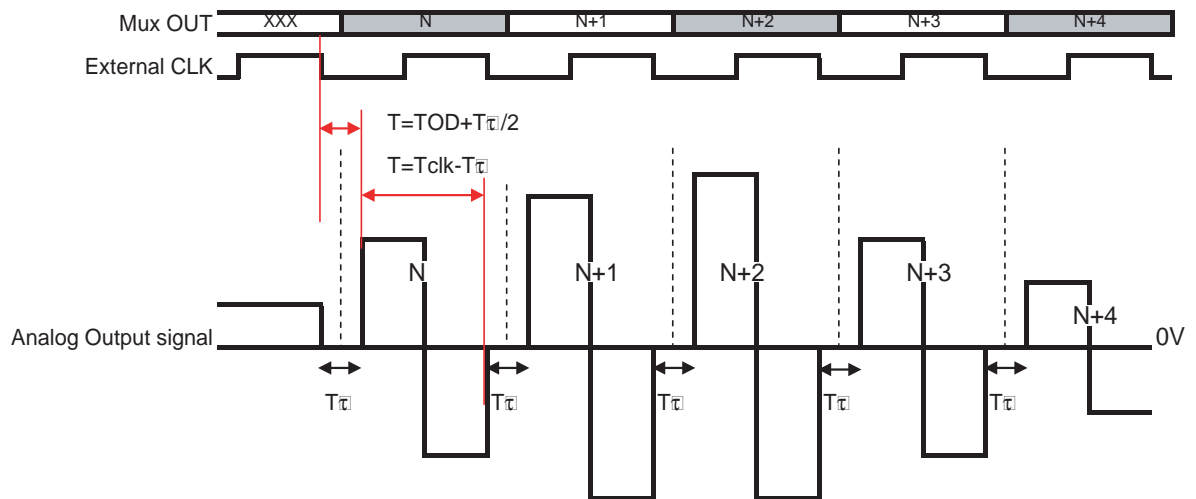

Note: The central transition is not hazardous but its elimination allows to push clock spur to $2 \cdot F_s$.
 $T\tau$ is independent of F_{clock} .

5.4 Input Under Clocking Mode (IUCM), Principle and Spectral Response

An Input Under Clocking Mode has been added to the DAC in order to allow the DAC input data rate to be at half the nominal rate with respect of the DAC sampling rate.

When the under clocking mode is activated, the DAC expects data at half the nominal rate: if the DAC works at F_s sampling rate, then in 4:1 MUX mode, the input data rate should be $F_s/4$ and the DSP clock should be $F_s/(2N \cdot OCDS)$, with $N = \text{MUX ratio}$ and $OCDS = \text{OCDS Ratio}$.

When the IUCM is active, the input data rate can be $F_s/8$ and the DSP clock frequency is $F_s/(2N \cdot OCDS \cdot 2)$, with $N = \text{MUX ratio}$ and $OCDS = \text{OCDS Ratio}$. This means that in input under clocking mode, the DAC is capable to treat data at half the nominal rate. In this case, the DSP clock is also half its nominal speed.

Label	Logic Value	Description
IUCM	0	Input Under Clocking Mode inactive
	1	Input Under Clocking Mode active

To disable this mode, the IUCM pin must be connected to GND.

To enable this mode, IUCM must be connected to V_{CCD} or left unconnected

The IUCM mode affects spectral response of the different modes.

The first effect is that Nyquist zone edges are not anymore at $n \cdot F_{clock}/2$ but at $n \cdot F_{clock}/4$ (direct consequence of the division by 2 of the data rate).

The second effect is the modification of the equations ruling the spectral responses in the different modes.

Ideal equations describing max available Pout for frequency domain in the four output modes when IUCM mode is activated are given hereafter, with $X =$ normalised output frequency (that is F_{out}/F_{clock} , edges of Nyquist Zones are then at $X = 0, 1/4, 1/2, 3/4, 1, \dots$)

In fact due to limited bandwidth, an extra term must be added to take in account a first order low pass filter with a 6 GHz cut-off frequency.

NRZ mode:

$$P_{out}(X) = 20 \cdot \log_{10} \cdot \left[\frac{k \cdot \text{sinc}(k \cdot \pi \cdot X) \cdot \cos(\pi \cdot X)}{0.893} \right]$$

where $\text{sinc}(x) = \sin(x)/x$, and $k = 1$

NRTZ mode:

$$P_{out}(X) = 20 \cdot \log_{10} \cdot \left[\frac{k \cdot \text{sinc}(k \cdot \pi \cdot X) \cdot \cos(\pi \cdot X)}{0.893} \right] \quad k = \frac{T_{clk} - T_{\tau}}{T_{clk}}$$

where T_{τ} is width of reshaping pulse, T_{τ} is about 75ps.

RTZ mode:

$$P_{out}(X) = 20 \cdot \log_{10} \cdot \left[\frac{k \cdot \text{sinc}(k \cdot \pi \cdot X) \cdot \cos(\pi \cdot X)}{0.893} \right]$$

where k is the duty cycle of the clock presented at the DAC input, please note that due to phase mismatch in balun used to convert single ended clock to differential clock the first zero may move around the limit of the 4th and the 5th Nyquist zones. Ideally $k = 1/2$.

RF mode:

$$P_{out}(X) = 20 \cdot \log_{10} \cdot \left[\frac{k \cdot \text{sinc}\left(\frac{k \cdot \pi \cdot X}{2}\right) \cdot \sin\left(\frac{k \cdot \pi \cdot X}{2}\right) \cdot \cos(\pi \cdot X)}{0.893} \right]$$

where k is as per in NRTZ mode.

Figure 5-8. Max available Pout[dBm] at nominal gain vs Fout[GHz] in the four output modes at 3 GSps, combined with IUCM, over four nyquist zones, computed for $T\tau = 75$ ps.

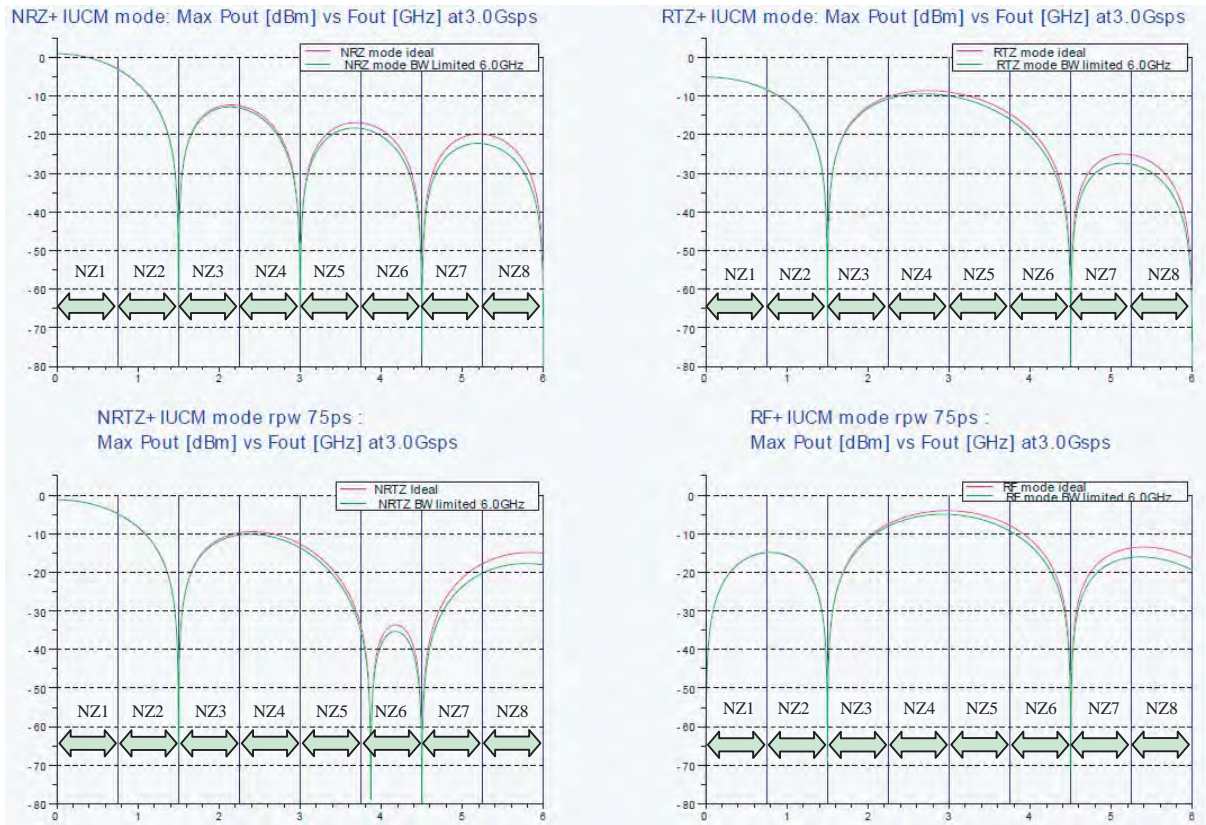
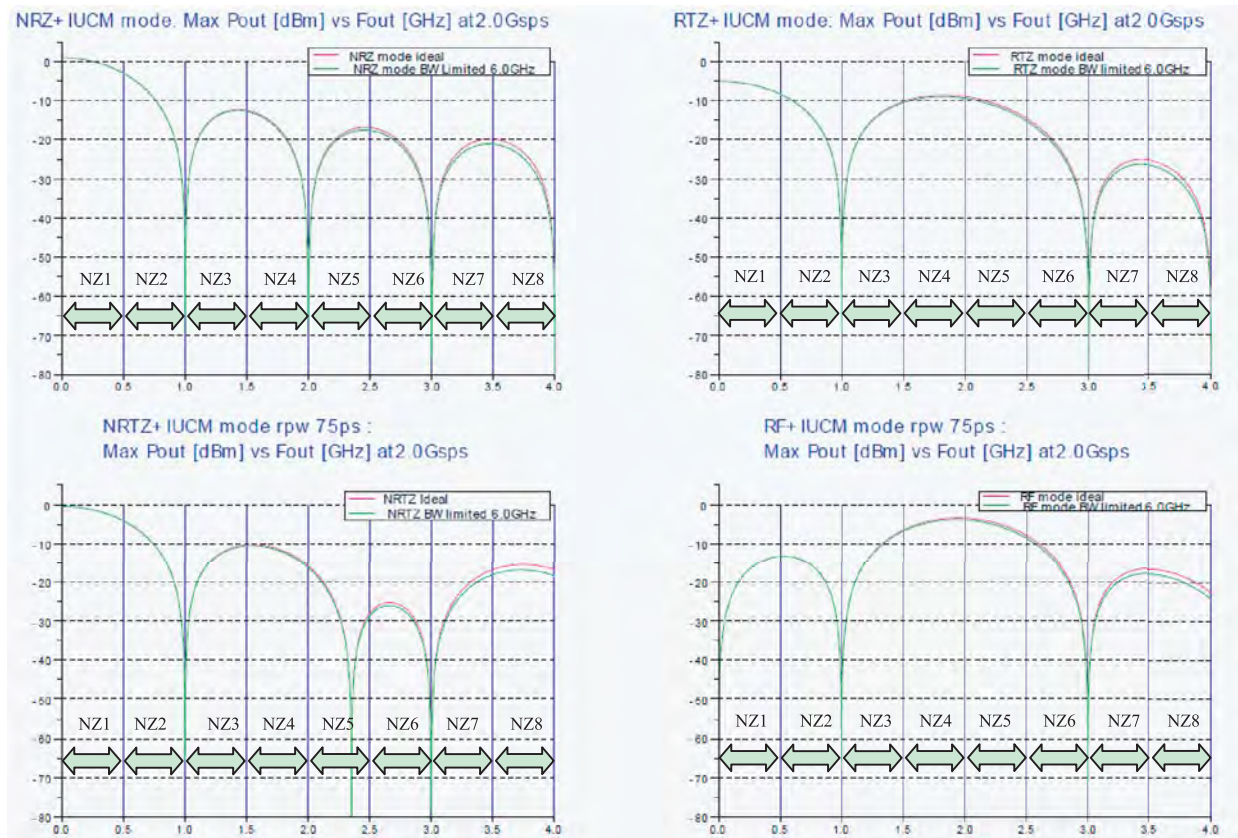

Figure 5-9. Max available Pout[dBm] at nominal gain vs Fout[GHz] in the four output modes at 2 GSps, combined with IUCM, over four nyquist zones, computed for $T\tau = 75$ ps



5.5 PSS (Phase Shift Select Function)

It is possible to adjust the timings between the sampling clock and the DSP output clock (which frequency is given by the following formula: Sampling clock / $2NX$ where N is the MUX ratio, X the output clock division factor).

The DSP clock output phase can be tuned over a range of 3.5 input clock cycles (7 steps of half a clock cycle) in addition to the intrinsic propagation delay between the DSP clock (DSP, DSPN) and the sampling clock (CLK, CLKN).

Three bits are provided for the phase shift function: PSS[2:0].

By setting these 3 bits to 0 or 1, one can add a delay on the DSP clock in order to properly synchronize the input data of the DAC and the sampling clock (the DSP clock should be applied to the FPGA and should be used to clock the DAC digital input data).

Table 5-2. PSS Coding Table

Label	Value	Description
PSS[2:0]	000	No additional delay on DSP clock
	001	0.5 input clock cycle delay on DSP clock
	010	1 input clock cycle delay on DSP clock
	011	1.5 input clock cycle delay on DSP clock
	100	2 input clock cycle delay on DSP clock
	101	2.5 input clock cycle delay on DSP clock
	110	3 input clock cycle delay on DSP clock
	111	3.5 input clock cycle delay on DSP clock

In order to determine how much delay needs to be added on the DSP clock to ensure the synchronization between the input data and the sampling clock within the DAC, the HTVF and STVF bits should be monitored. Refer to [Section 5.7 on page 29](#).

Note: In MUX 4:1 mode the 8 settings are relevant, in MUX 2:1 only the four first settings are relevant since the four last ones will yield exactly the same results.

Figure 5-10. PSS Timing Diagram for 4:1 MUX, OCDS[00]

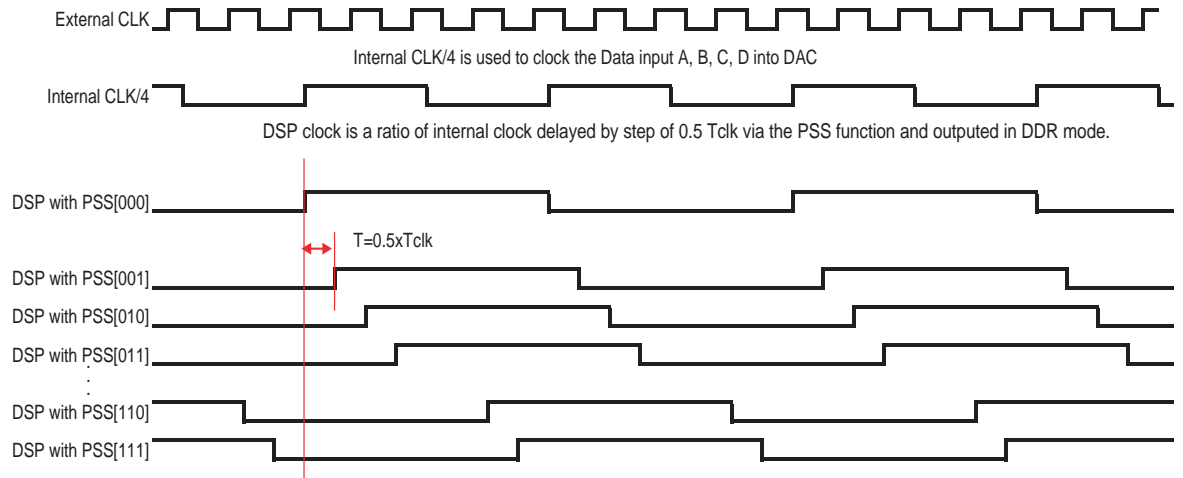
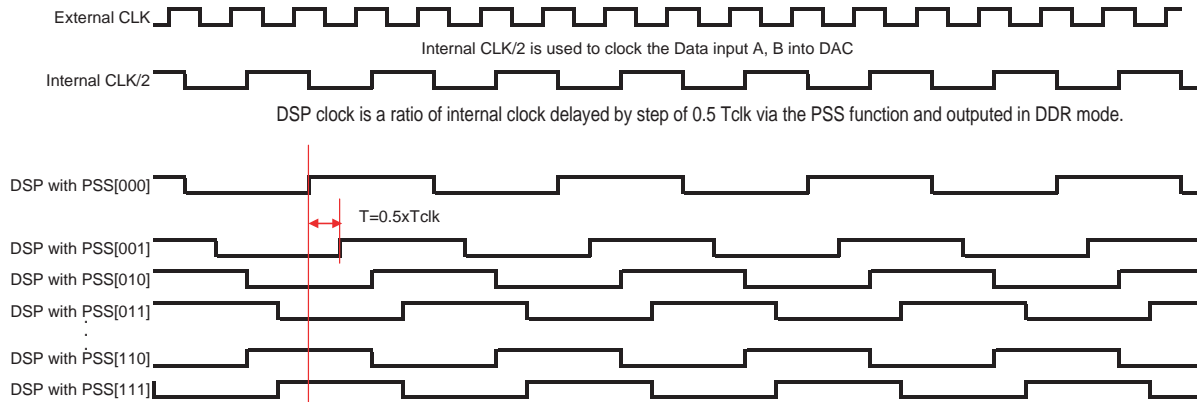

Figure 5-11. PSS Timing Diagram for 2:1 MUX, OCDS[00]



5.6 Output Clock Division Select Function

It is possible to change the DSP clock internal division factor from 1 to 2 with respect to the sampling clock/ $2N$ where N is the MUX ratio. This is possible via the OCDS "Output Clock Division Select" bits.

OCDS is used to obtain a synchronization clock for the FPGA slow enough to allow the FPGA to operate with no further internal division of this clock, thus its internal phase is determined by the DSP clock phase. This is useful in a system with multiple DACs and multiple FPGAs to guarantee deterministic phase relationship between the FPGAs after a synchronization of all the DACs.

Table 5-3. OCDS[1:0] Coding Table

Label	Value	Description
OCDS [1:0]	00	DSP clock frequency is equal to the sampling clock divided by $2N$
	01	DSP clock frequency is equal to the sampling clock divided by $2N \times 2$
	10	Not allowed
	11	Not allowed

Figure 5-12. OCDS Timing Diagram for 4:1 MUX

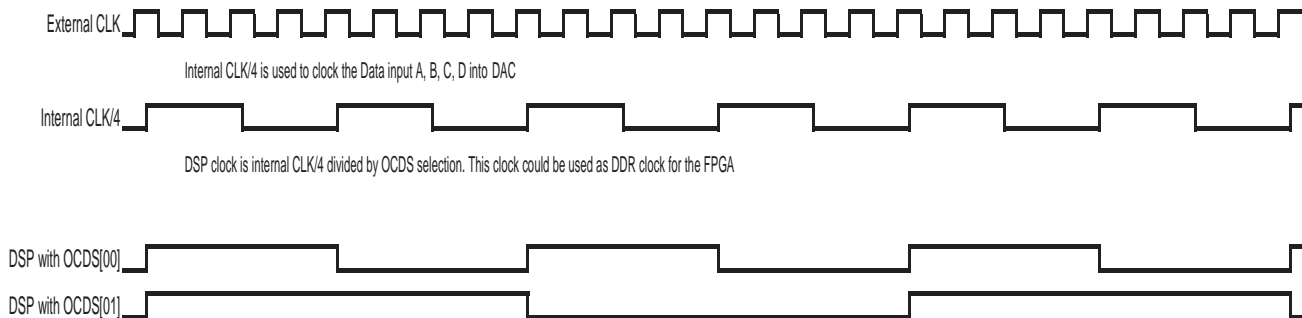
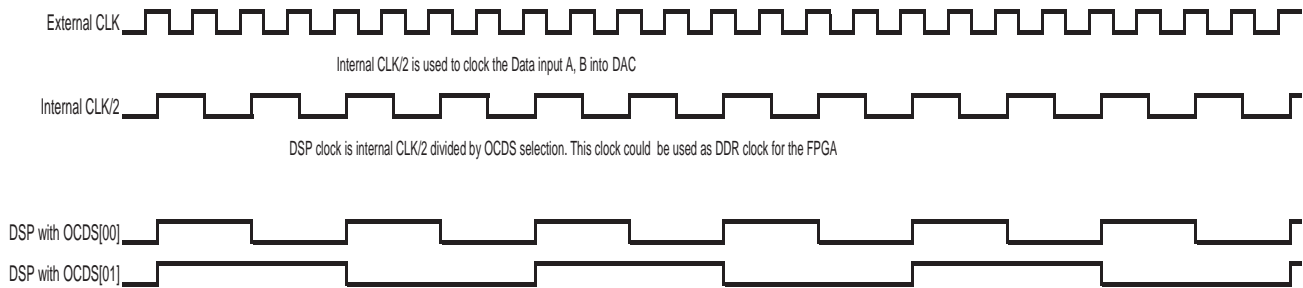

Figure 5-13. OCDS Timing Diagram for 2:1 MUX



5.7 Synchronization FPGA-DAC: IDC_P, IDC_N, HTVF and STVF Functions

IDC_P, IDC_N: Input Data check function (LVDS signal).

HTVF: Hold Time Violation Flag. (cmos3.3V signal)

STVF: Setup Time Violation Flag. (cmos3.3V signal)

IDC signal is toggling at each cycle synchronously with other data bits. It should be considered as a DAC input data that toggles at each cycle.

This signal should be generated by the FPGA in order for the DAC to check in real-time if the timings between the FPGA and the DAC are correct.

Figure 5-14. IDC Timing vs Data Input

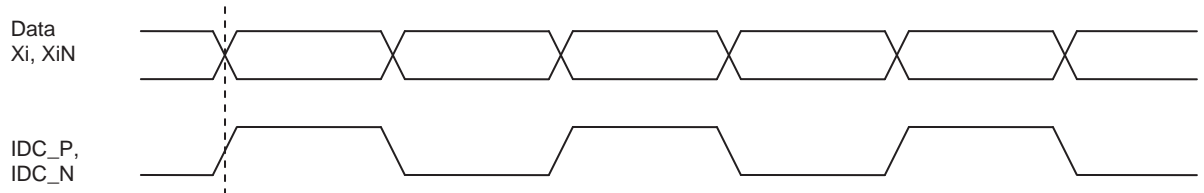

The information on the timings is then given by HTVF, STVF signals (flags).

Table 5-4. HTVF, STVF Coding Table

Label	Value	Description
HTVF	0	SYNCHRO OK
	1	Data Hold time violation detected
STVF	0	SYNCHRO OK
	1	Data Setup time violation detected

During monitoring STVF indicates setup time of data violation (Low -> OK, High -> Violation), HTVF indicates hold time of data violation (Low -> OK, High -> Violation).

Figure 5-15. FPGA to DAC Synoptic

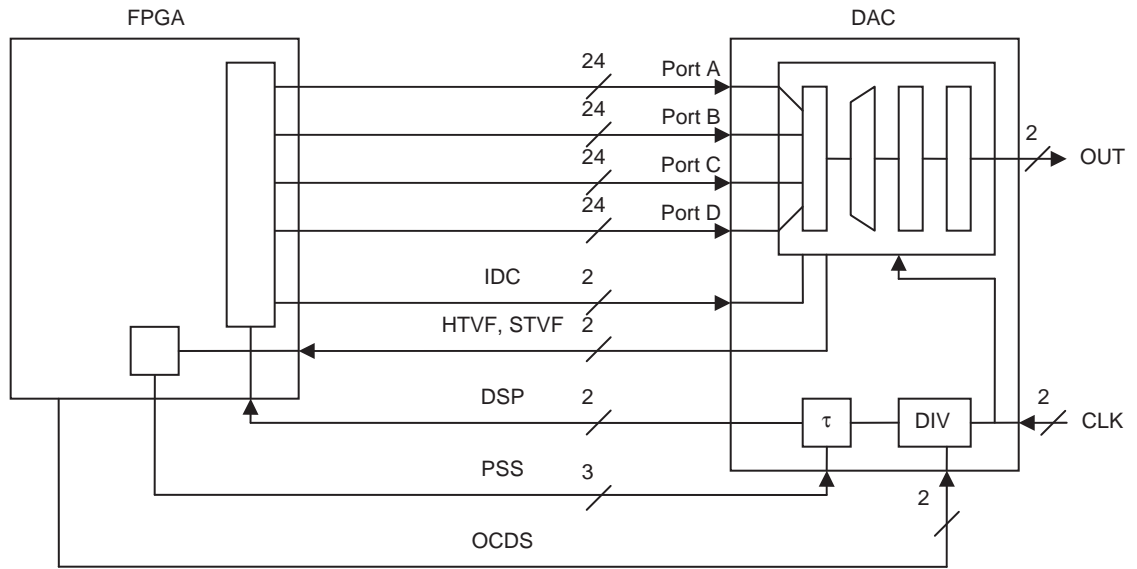

Principle of Operation:

The Input Data Check pair (IDC_P, IDC_N) will be sampled three times with half a master clock period shift (the second sample being synchronous with all the data sampling instant), these three samples will be compared, and depending on the results of the comparison a violation may be signalled.

- Violation of setup time -> STVF is high level
- Violation of hold time -> HTVF is high level

In case of violation of timing (setup or hold) the user has two solutions:

- Shift phase in the FPGA PLL (if this functionality is available in FPGA) for changing the internal timing of DATA and Data Check signal inside FPGA.
- Shift the DSP clock timing (Output clock of the DAC which can be used for FPGA synchronization – refer to [Section 5.5 on page 26](#)), in this case this shift also shift the internal timing of FPGA clock.

Note: When used, it should be routed as the data signals (same layout rules and same length). if not used, it should be driven to an LVDS low or high level.

For further details, refer to application note AN1087.

5.8 OCDS, MUX Combinations Summary

Table 5-5. OCDS, IUCM, MUX, PSS Combinations Summary

MUX		IUCM		OCDS		PSS range	Data rate	Comments
0	4:1	1	ON	00	DSP clock division factor 16	0 to 7/(2Fs) by 1/(2Fs) steps	Fs/8	Refer to Section 5.6
0		1		01	DSP clock division factor 32			
0		1		10	Not allowed			
0		1		11	Not allowed			
0		0	OFF, normal mode	00	DSP clock division factor 8	0 to 7/(2Fs) by 1/(2Fs) steps	Fs/4	
0		0		01	DSP clock division factor 16			
0		0		10	Not allowed			
0		0		11	Not allowed			
1	2:1	1	ON	00	DSP clock division factor 8	0 to 7/(2Fs) by 1/(2Fs) steps	Fs/4	Not recommended mode, not guaranteed
1		1		01	DSP clock division factor 16			
1		1		10	Not allowed			
1		1		11	Not allowed			
1		0	OFF, normal mode	00	DSP clock division factor 4	0 to 7/(2Fs) by 1/(2Fs) steps	Fs/2	
1		0		01	DSP clock division factor 8			
1		0		10	Not allowed			
1		0		11	Not allowed			

Note: Behaviour according to MUX, OCDS and PSS combination is independent of output mode (MODE).

5.9 Synchronization functions for multi-DAC operation

In order to synchronize the timings, a SYNC operation can be generated.

After the application of the SYNC signal the DSP clock from the DAC will stop for a period and after a constant and known time the DSP clock will start up again.

There are two SYNC functions integrated in this DAC:

- a power up reset, which is triggered by the power supplies if the dedicated power up sequence is applied $V_{ccd} \Rightarrow V_{cca3} \Rightarrow V_{cca5}$;
- External SYNC pulse applied on (SYNC, SYNCN).

The external SYNC is LVDS compatible (same buffer as for the digital input data). It is active high.

Depending on the settings for OCDS, PSS and also the MUX ratio the width of the SYNC pulse must be greater than a certain number of external clock pulses. It is also necessary that the sync pulse be synchronized with the system clock and is an integer number of clock pulses. See application note (ref 1087) for further details.

Figure 5-16. Reset Timing Diagram (4:1 MUX)

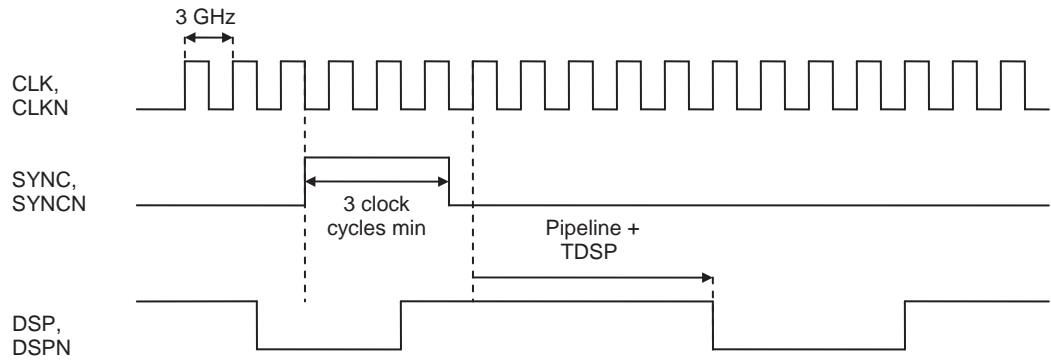
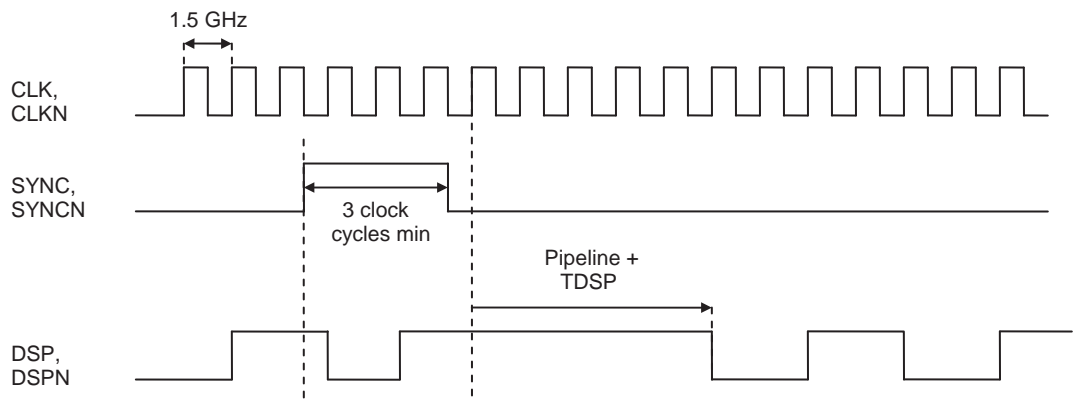

Figure 5-17. Reset Timing Diagram (2:1 MUX)



Important note:

For EV12DS130A:

- See erratasheet (ref 1125) for SYNC condition of use.
- SYNC, SYNCN pins have to be driven.

For EV12DS130B:

- SYNC, SYNCN pins can be left floating if unused.
- No specific timing constraints (other than T1 and T2) are required.

5.10 Gain Adjust GA Function

This function allows to adjust the internal gain of the DAC to cancel the initial gain deviation.

The gain of the DAC can be adjusted by $\pm 11\%$ by tuning the voltage applied on GA by varying GA potential from 0 to V_{CCA3} .

GA max is given for GA = 0 and GA min for GA = V_{CCA3}

5.11 Diode Function

A diode is available to monitor the die junction temperature of the DAC.
For the measurement of die junction temperature, you may use a temperature sensor.

Figure 5-18. Temperature DIODE Implementation

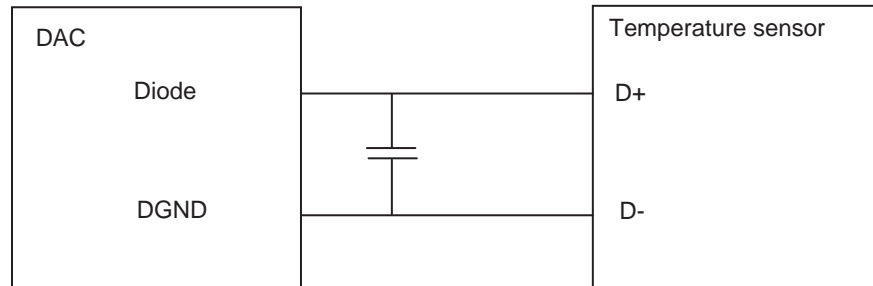

In characterization measurement a current of 1 mA is applied on the DIODE pin. The voltage across the DIODE pin and the DGND pin gives the junction temperature using the intrinsic diode characteristics below [Figure 5-19](#).

Figure 5-19. Diode Characteristics for Die Junction Monitoring

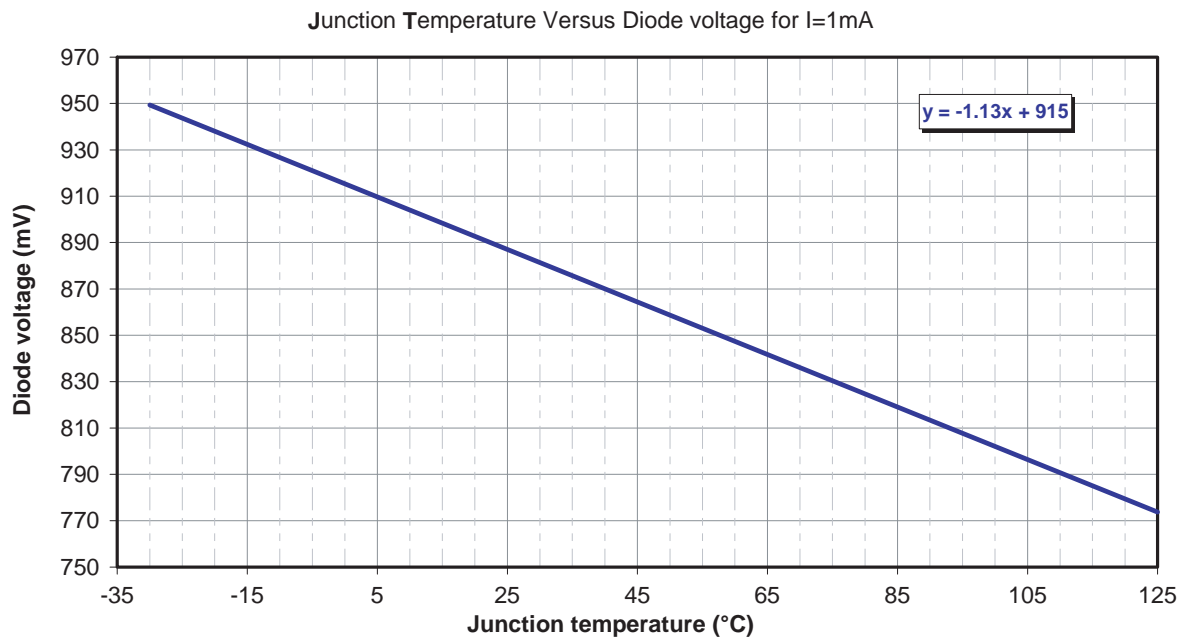

6. PIN DESCRIPTION

Figure 6-1. Pinout View (Top View)

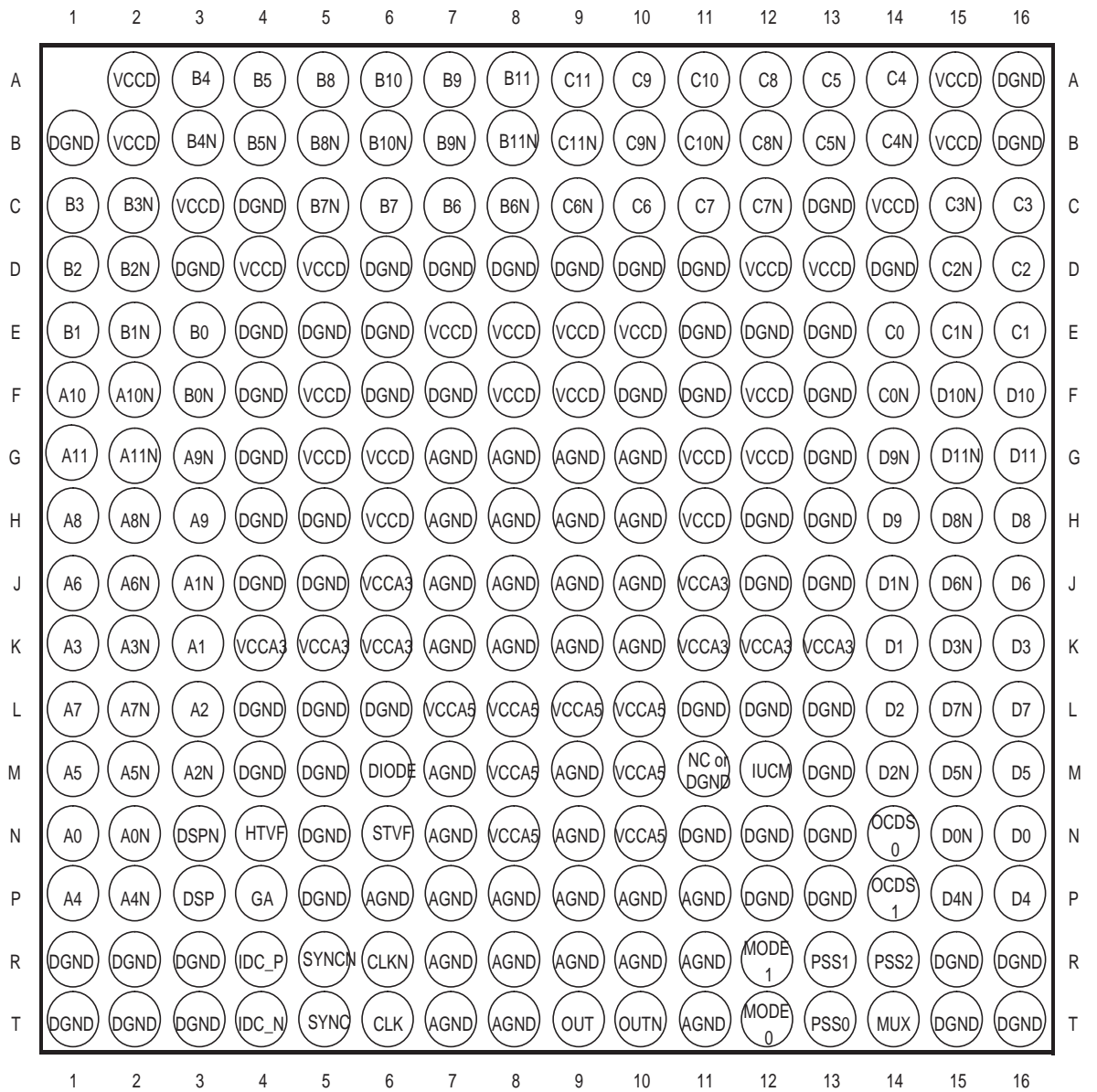

Table 6-1. Pinout Table

Signal Name	Pin number	Description	Direction	Equivalent simplified schematics
Power supplies				
VCCA5	L7, L8, L9, L10, M8, M10, N8, N10	5.0V analog power supplies Referenced to AGND		
VCCA3	J6, J11, K4, K5, K6, K11, K12, K13	3.3V analog power supply Referenced to AGND	NA	
VCCD	A2, A15, B2, B15, C3, C14, D4, D5, D12, D13, E7, E8, E9, E10, F5, F8, F9, F12, G5, G6, G11, G12, H6, H11	3.3V digital power supply Referenced to DGND	NA	
AGND	G7, G8, G9, G10, H7, H8, H9, H10, J7, J8, J9, J10, K7, K8, K9, K10, M7, M9, N7, N9, P6, P7, P8, P9, P10, P11, R7, R8, R9, R10, R11, T7, T8, T11	Analog Ground	NA	
DGND	A16, B1, B16, C4, C13, D3, D6, D7, D8, D9, D10, D11, D14, E4, E5, E6, E11, E12, E13, F4, F6, F7, F10, F11, F13, G4, G13, H4, H5, H12, H13, J4, J5, J12, J13, L4, L5, L6, L11, L12, L13, M4, M5, M13, N5, N11, N12, N13, P5, P12, P13, R1, R2, R3, R15, R16, T1, T2, T3, T15, T16	Digital Ground	NA	
Clock Signals				
CLK, CLKN	T6, R6	Sampling clock signal input (In-phase and inverted phase)	I	

Table 6-1. Pinout Table (Continued)

Signal Name	Pin number	Description	Direction	Equivalent simplified schematics
DSP, DSPN	P3, N3	Output clock (in-phase and inverted phase)	O	
Analog Output Signal				
OUT, OUTN	T9, T10	In phase and inverted phase analog output signal (differential termination required)	O	
Digital Input Signals				
A0, A0N A1, A1N A2, A2N A3, A3N A4, A4N A5, A5N A6, A6N A7, A7N A8, A8N A9, A9N A10, A10N A11, A11N	N1, N2 K3, J3 L3, M3 K1, K2 P1, P2 M1, M2 J1, J2 L1, L2 H1, H2 H3, G3 F1, F2 G1, G2	In-phase, inverted phase Digital input Port A Data A0, A0N is the LSB Data A11, A11N is the MSB	I	

Table 6-1. Pinout Table (Continued)

Signal Name	Pin number	Description	Direction	Equivalent simplified schematics
B0, B0N B1, B1N B2, B2N B3, B3N B4, B4N B5, B5N B6, B6N B7, B7N B8, B8N B9, B9N B10, B10N B11, B11N	E3, F3 E1, E2 D1, D2 C1, C2 A3, B3 A4, B4 C7, C8 C6, C5 A5, B5 A7, B7 A6, B6 A8, B8	In-phase, inverted phase Digital input Port B Data B0, B0N is the LSB Data B11, B11N is the MSB	I	
C0, C0N C1, C1N C2, C2N C3, C3N C4, C4N C5, C5N C6, C6N C7, C7N C8, C8N C9, C9N C10, C10N C11, C11N	E14, F14 E16, E15 D16, D15 C16, C15 A14, B14 A13, B13 C10, C9 C11, C12 A12, B12 A10, B10 A11, B11 A9, B9	In-phase, inverted phase Digital input Port D Data D0, D0N is the LSB Data D11, D11N is the MSB	I	
D0, D0N D1, D1N D2, D2N D3, D3N D4, D4N D5, D5N D6, D6N D7, D7N D8, D8N D9, D9N D10, D10N D11, D11N	N16, N15 K14, J14 L14, M14 K16, K15 P16, P15 M16, M15 J16, J15 L16, L15 H16, H15 H14, G14 F16, F15 G16, G15	In-phase, inverted phase Digital input Port D Data D0, D0N is the LSB Data D11, D11N is the MSB	I	
IDC_P IDC_N	R4 T4	Input data check	I	
SYNC, SYNCR	T5 R5	In phase and Inverted phase reset signal	I	

Table 6-1. Pinout Table (Continued)

Signal Name	Pin number	Description	Direction	Equivalent simplified schematics
Control Signals				
HTVF	N4	Hold time violation flag	O	
STVF	N6	Setup time violation flag	O	
PSS0 PSS1 PSS2	T13 R13 R14	Phase Shift Select (PSS2 is the MSB)	I	
MODE0 MODE1	T12 R12	DAC Mode selection bits: - RTZ - NRZ - Narrow RTZ - RF	I	
OCDS0 OCDS1	N14 P14	Output Clock Division Select = these bits allow to select the clock division factor applied on the DSP, DSPN signal.	I	
MUX	T14	MUX selection:	I	
IUCM	M12	Input underclocking mode enable	I	
GA	P4	Gain adjust	I	

Table 6-1. Pinout Table (Continued)

Signal Name	Pin number	Description	Direction	Equivalent simplified schematics
Diode	M6	Diode for die junction temperature monitoring function	I	
NC	M11	Reserved pin, NC, can be connected to DGND		

7. CHARACTERIZATION RESULTS

Unless otherwise specified results are given at room temperature ($T_j \sim 60^\circ\text{C}$), nominal power supply, in 4:1 MUX mode, gain at nominal setting.

7.1 Static Performances

7.1.1 DC Gain Characterization

Figure 7-1. DAC DC Gain vs Gain Adjust (Measured in NRZ Mode)

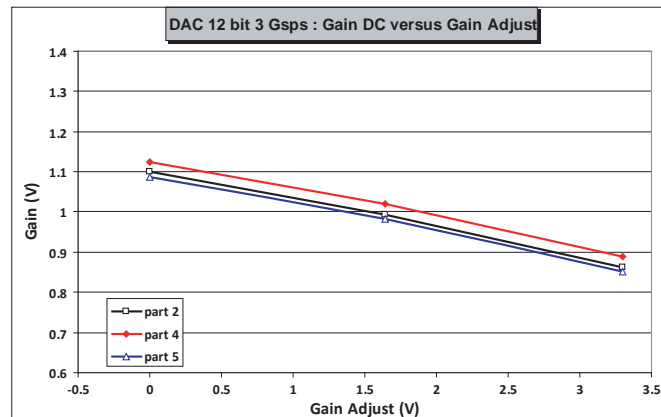

Figure 7-2. DAC DC Gain Drift from Unity Gain vs Temperature (Measured in NRZ Mode)

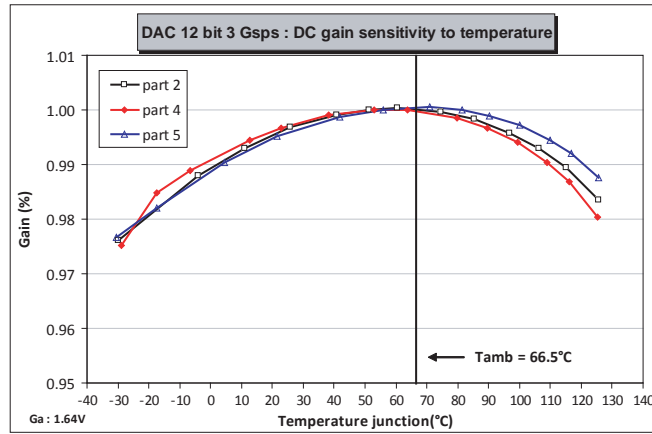
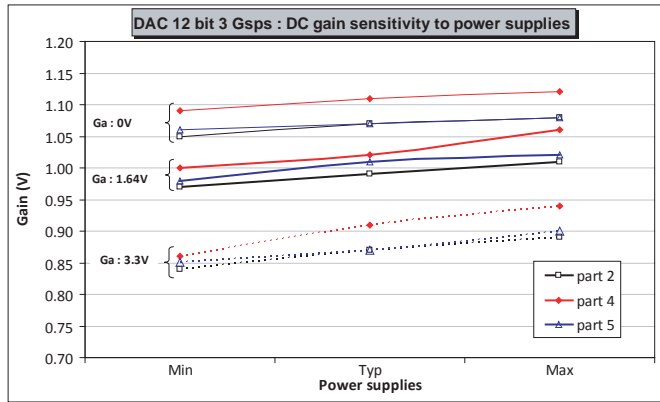

Figure 7-3. DC Gain Sensitivity to Power Supply (Measured in NRZ Output Mode)



Conditions: room temperature, supply levels:
 - Min: V_{CCA} : 4.75V // $V_{CCA3} = V_{CCD} = 3.15V$
 - Typ: V_{CCA} : 5V // $V_{CCA3} = V_{CCD} = 3.3V$
 - Max: V_{CCA} : 5.25V // $V_{CCA3} = V_{CCD} = 3.45V$

7.1.2 Static Linearity

Figure 7-4. INL/DNL Measurement at $f_{out} = 100$ kHz and 3 Gps

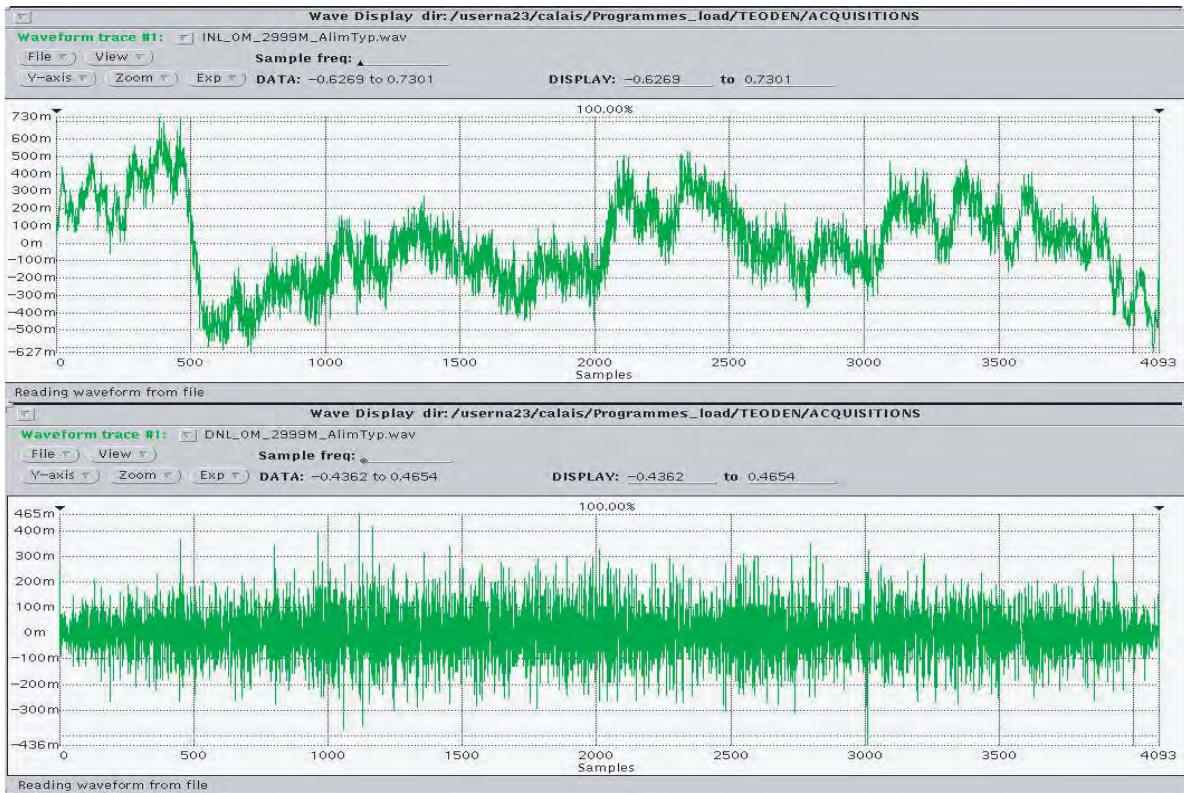

INL reflects a true 12 bit DAC.

Low DNL values reflect a strictly monotonous 12 bit DAC.

7.2 AC Performances

7.2.1 Available Output Power vs Fout.

The following plots summarize characterization results, for a Fout sweep from 98 MHz to 4498 MHz (step 100 MHz).

Figure 7-5. Available Pout vs Fout from 98 MHz to 4498 MHz in the 4 Output Modes at 3 Gps

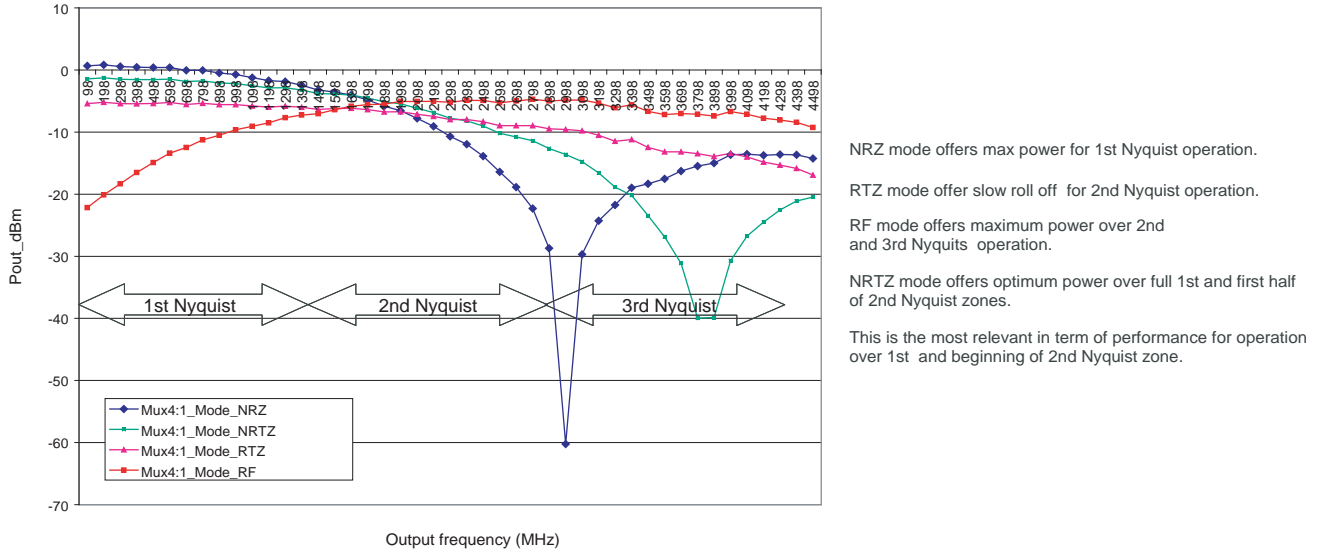

Figure 7-6. Available Pout vs Fout from 98 MHz to 4498 MHz and from 2 Gps to 3.2 Gps in NRZ Mode

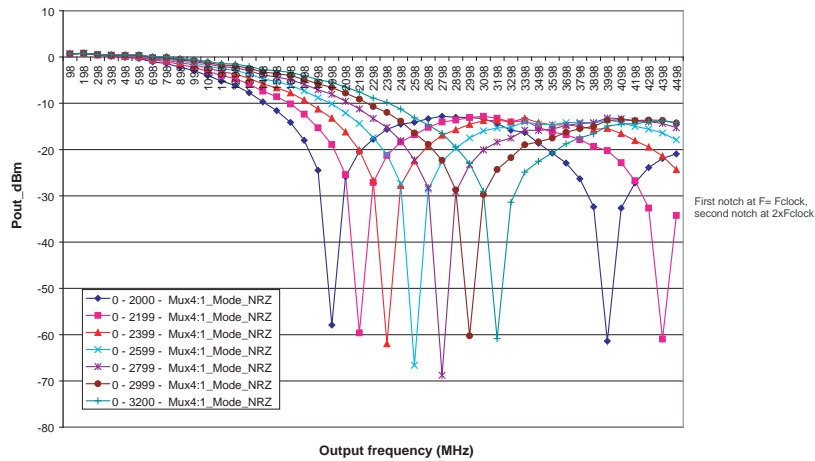

Figure 7-7. Available Pout vs Fout from 98 MHz to 4498 MHz and from 2 Gps to 3.2 Gps in NRTZ Mode

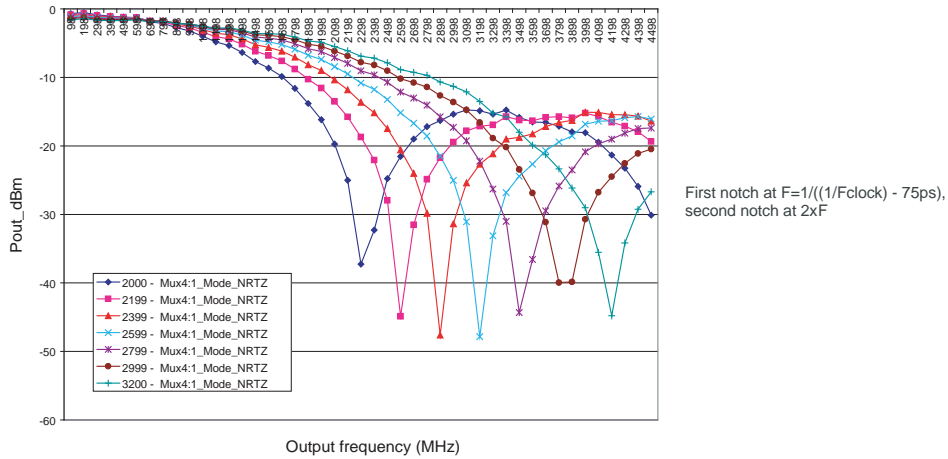

Figure 7-8. Available Pout vs Fout from 98 MHz to 4498 MHz and from 2 Gps to 3.2 Gps in RTZ Mode

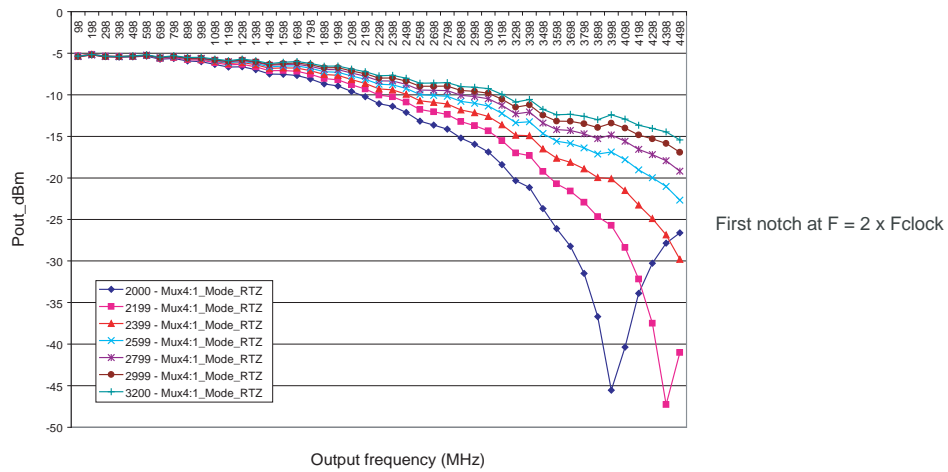
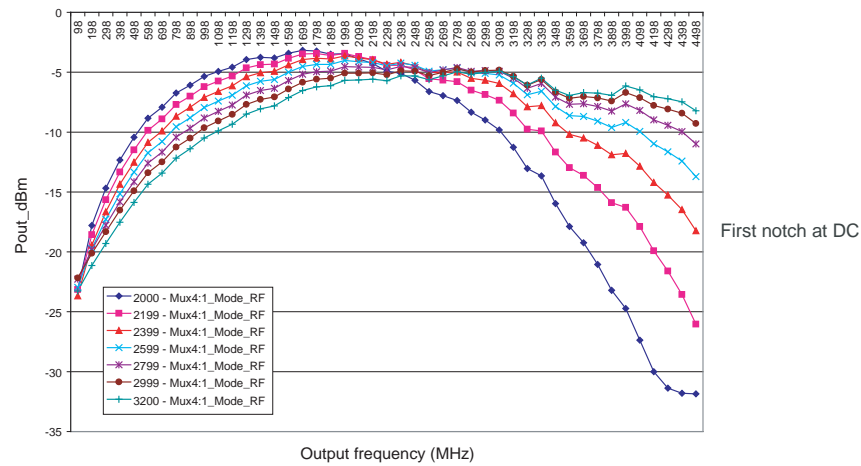

Figure 7-9. Available Pout vs Fout from 98 MHz to 4498 MHz and from 2 Gps to 3.2 Gps in RF Mode



7.2.2 Single Tone Measurements

The following plots summarize characterization results in MUX4:1 mode, for an Fout sweep from 98 MHz to 4498 MHz (step 100 MHz).

The left side of the plot gives SFDR expressed in dBc and the right side gives HSL (Highest Spur Level excluding Fclock spur) expressed in dBm.

Figure 7-10. SFDR and HSL in NRZ mode at -3 dBFS for Sampling Rate from 2000 MSps to 3200 MSps

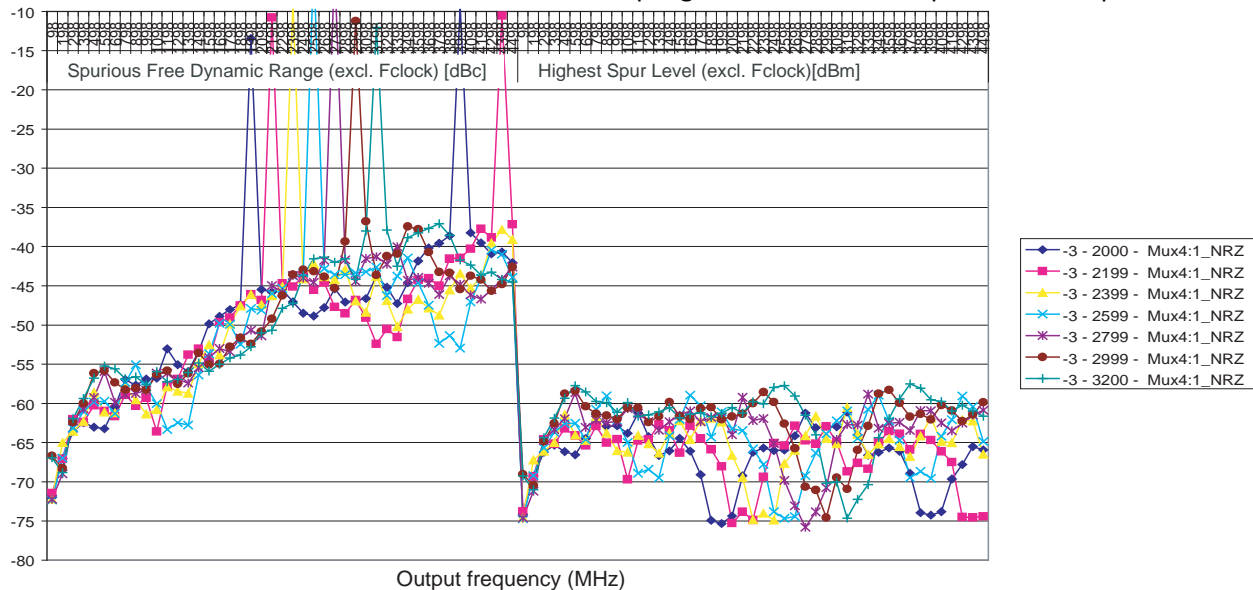

NRZ mode is only relevant for Fout below 400 MHz.

The spikes in the SFDR are caused by normalization artefacts due to the Sinc(x) null.

Figure 7-11. SFDR and HSL in NRTZ mode at -3 dBFS for Sampling Rate from 2000 MSps to 3200 MSps

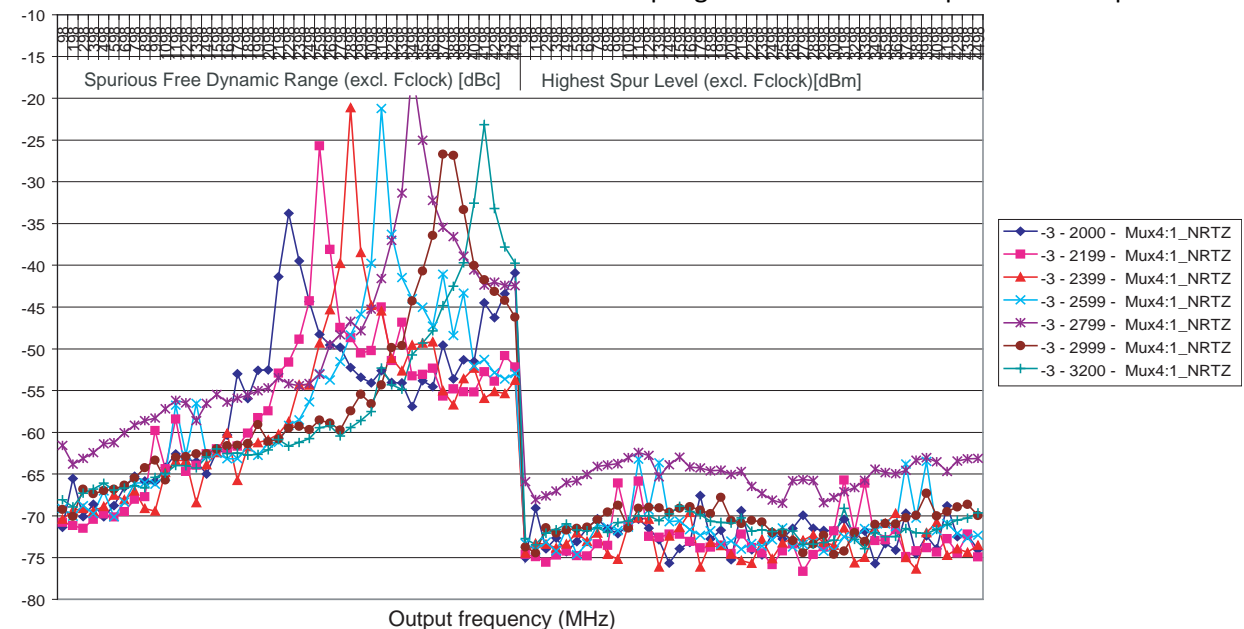

NRTZ mode brings significant improvement regarding NRZ mode. This mode concentrates the benefits of both NRZ mode (high power available) and RTZ mode (extended available dynamic range). The spikes in the SFDR are caused by normalization artefacts due to the Sinc(x) null.

Figure 7-12. SFDR and HSL in RTZ Mode at -3 dBFS for Sampling Rate from 2000 MSps to 3200 MSps

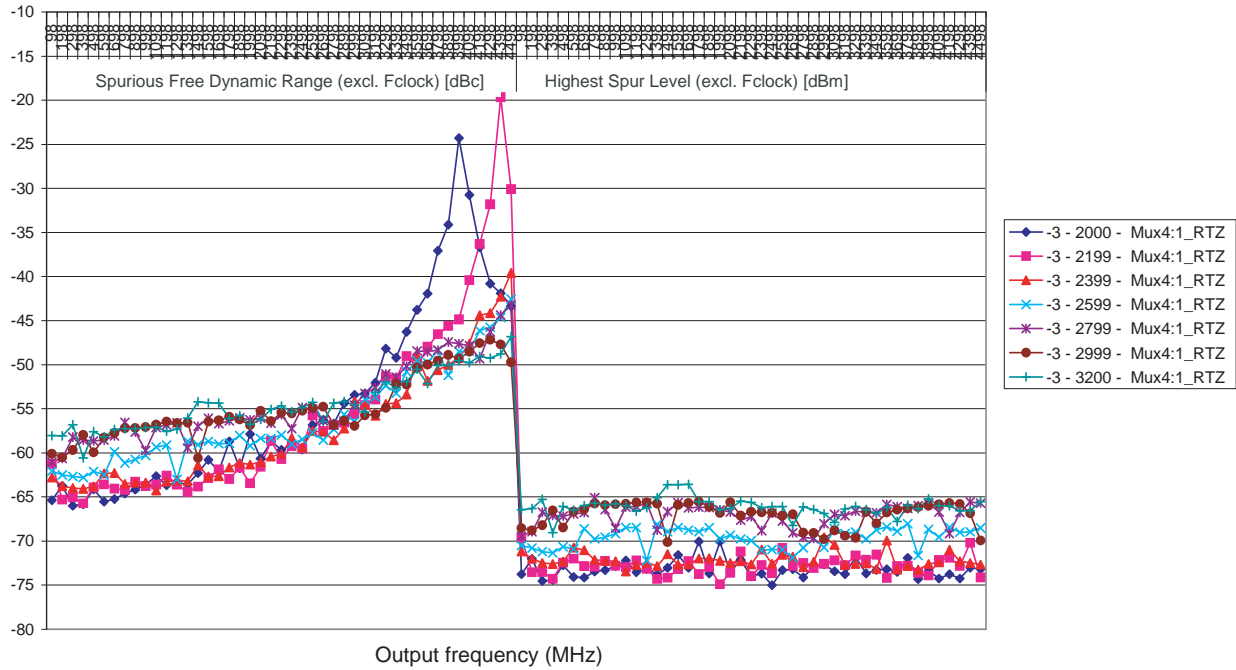

RTZ mode allows for operation over the 3 first Nyquist zones.

In first and beginning of second Nyquist zone NRTZ mode is mode relevant. The spikes in the SFDR are caused by normalization artefacts due to the Sinc(x) null.

Figure 7-13. SFDR and HSL in RF Mode at -3 dBFS for Sampling Rate from 2000 MSps to 3200 MSps

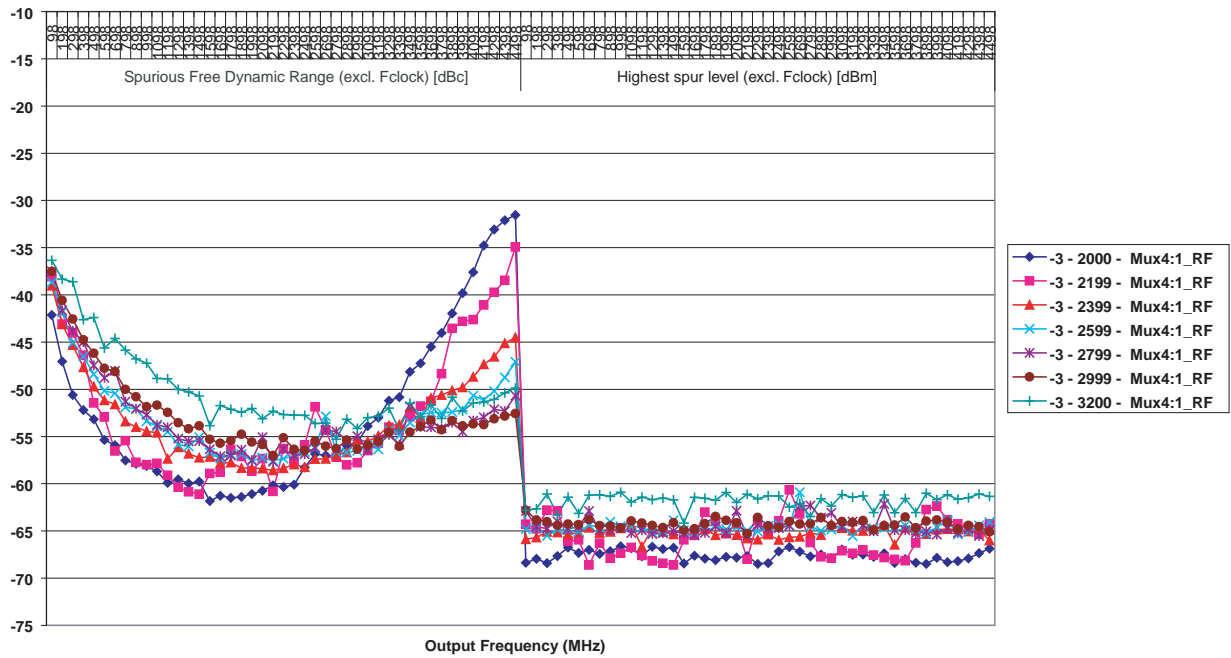

RF mode allows for operation over 3rd Nyquist zones. Performances are not sensitive to output level. Performance roll off occurs beyond 3000 MSps.

Figure 7-14. Comparison of the 4 Output Modes at 2999 MSps and at -3 dBFS: SFDR and HSL

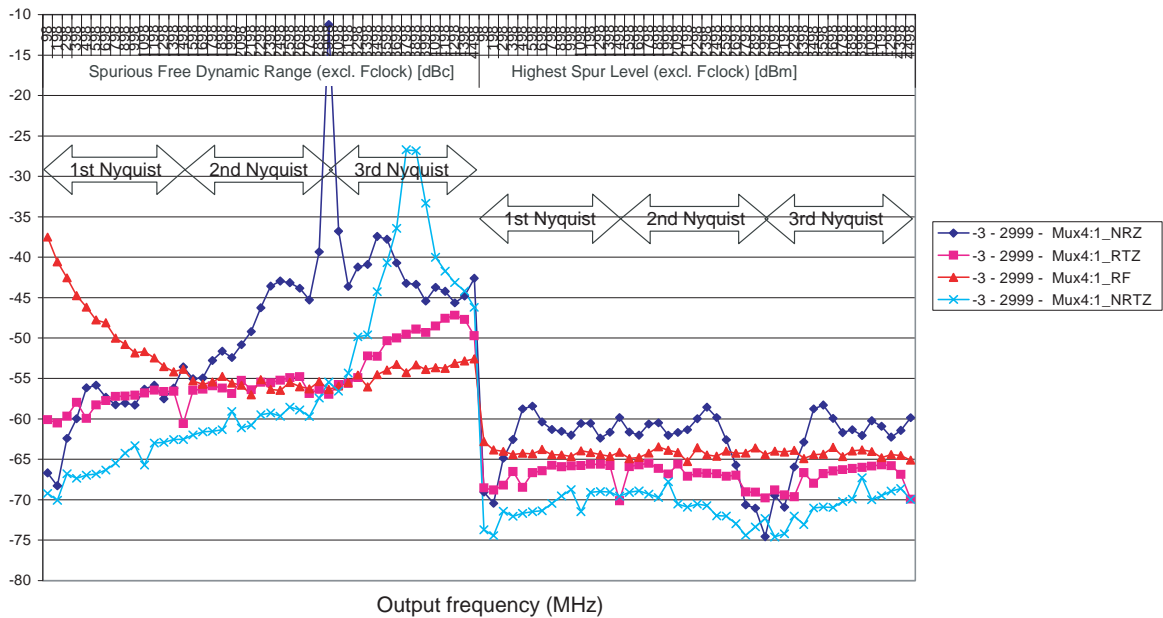

NRZ is interesting only at the very beginning of the first Nyquist zone.
 NRTZ is relevant over 1st 2nd and 4th Nyquist zones.
 RTZ is relevant over 2nd and 3rd Nyquist zones.
 RF mode displays a good behavior over 2nd and 3rd Nyquist Zones.
 The spikes in the SFDR are caused by normalization artefacts due to the Sinc(x) null

Figure 7-15. Comparison of the 4 Output Modes at 2000 MSps and -3 dBFS: SFDR and HSL

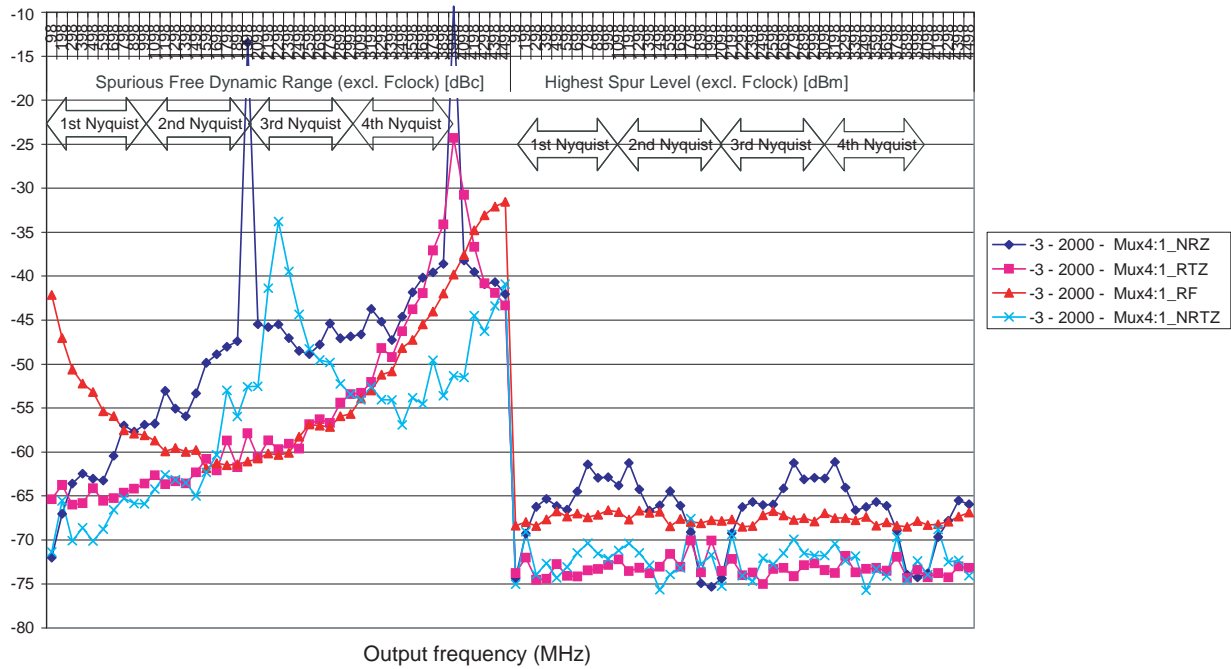

NRTZ is the most relevant over 1st Nyquist zone, 1st half of 2nd Nyquits zone and 4th Nyquist zone.
 RF mode is the best choice for 2nd half of 2nd Nyquist Zone and 3rd Nyquist zone.
 RTZ gives relevant performances over the three first Nyquist zones.
 The spikes in the SFDR are caused by normalization artefacts due to the Sinc(x) null

Figure 7-16. Comparison of NRZ and NRTZ Modes at Full Scale and -3 dBFS at 2999 MSps: SFDR and HSL (Excluding Fclock)

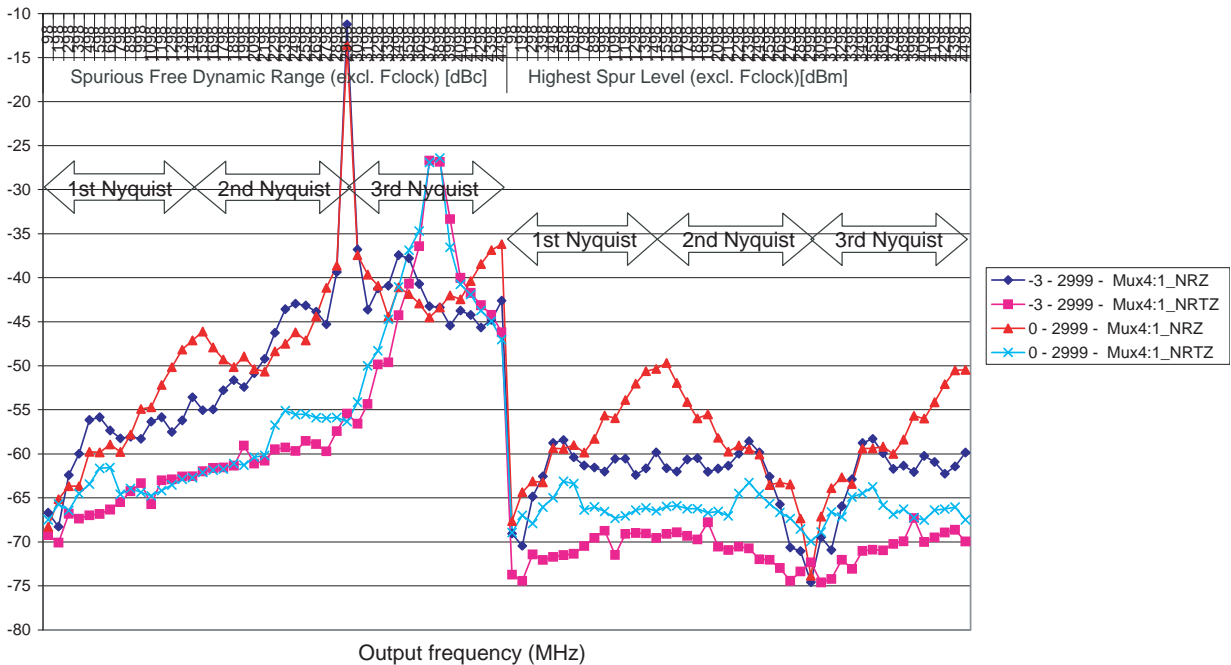

NRTZ gives better performances over 1st and 2nd Nyquist zone, and is much less sensitive to output level.

Figure 7-17. Comparison of NRTZ and RTZ Modes at Full Scale and -3 dBFS at 2999 MSps: SFDR and HSL

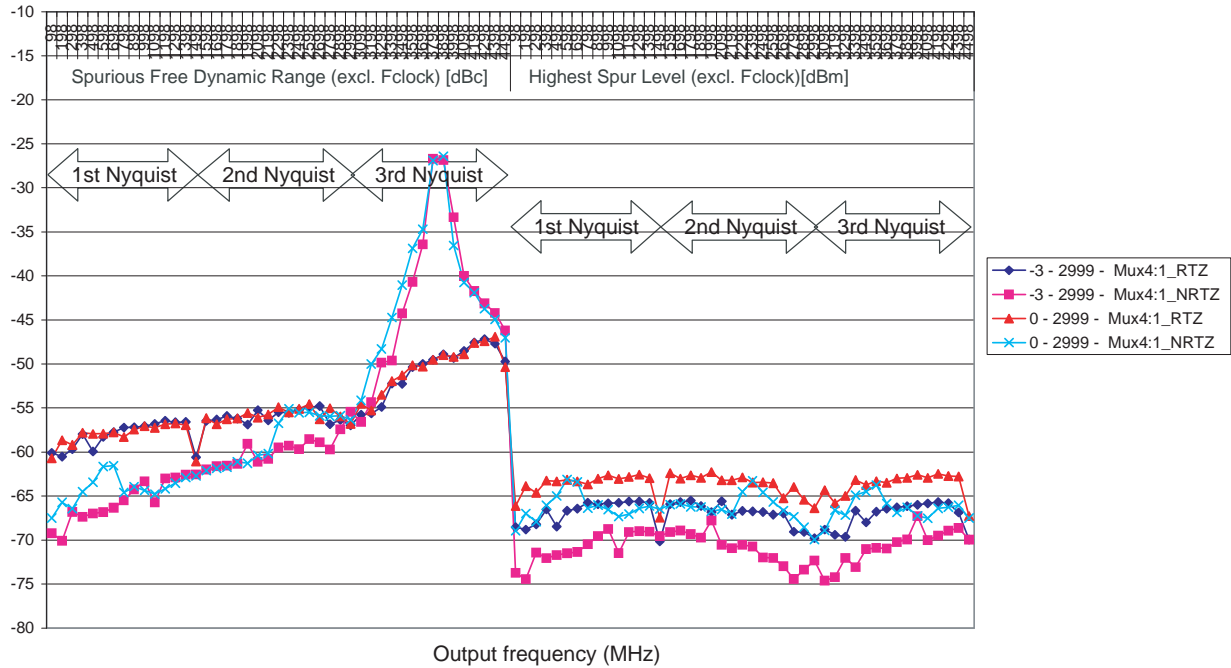

NRTZ is more relevant for 1st Nyquist zone and 1st half of 2nd Nyquist zone. Beyond middle of second Nyquist zone RTZ mode is more relevant.

Figure 7-18. Comparison of RTZ and RF Modes at Full Scale and -3 dBFS at 2999 MSps: SFDR and HSL

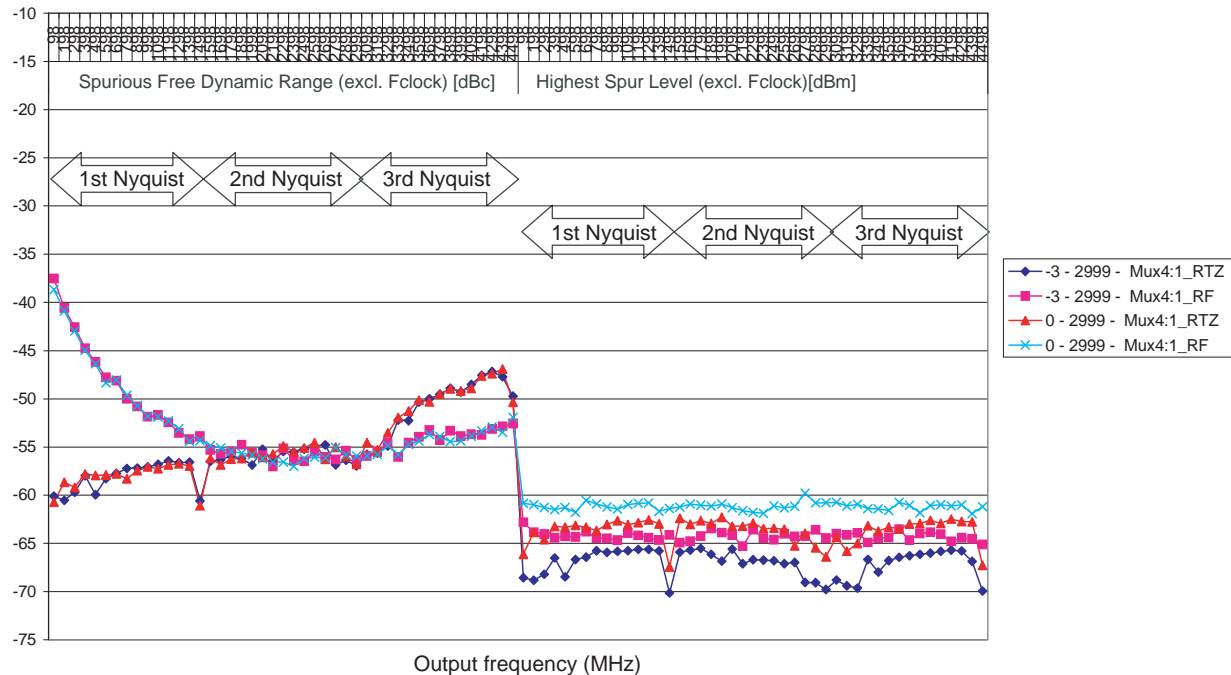

RF mode gives better performance over 3rd Nyquist zone.

Figure 7-19. Comparison of NRZ and NRTZ Modes at Full Scale and -3 dBFS at 2000 MSps: SFDR and HSL (Excluding Fclock)

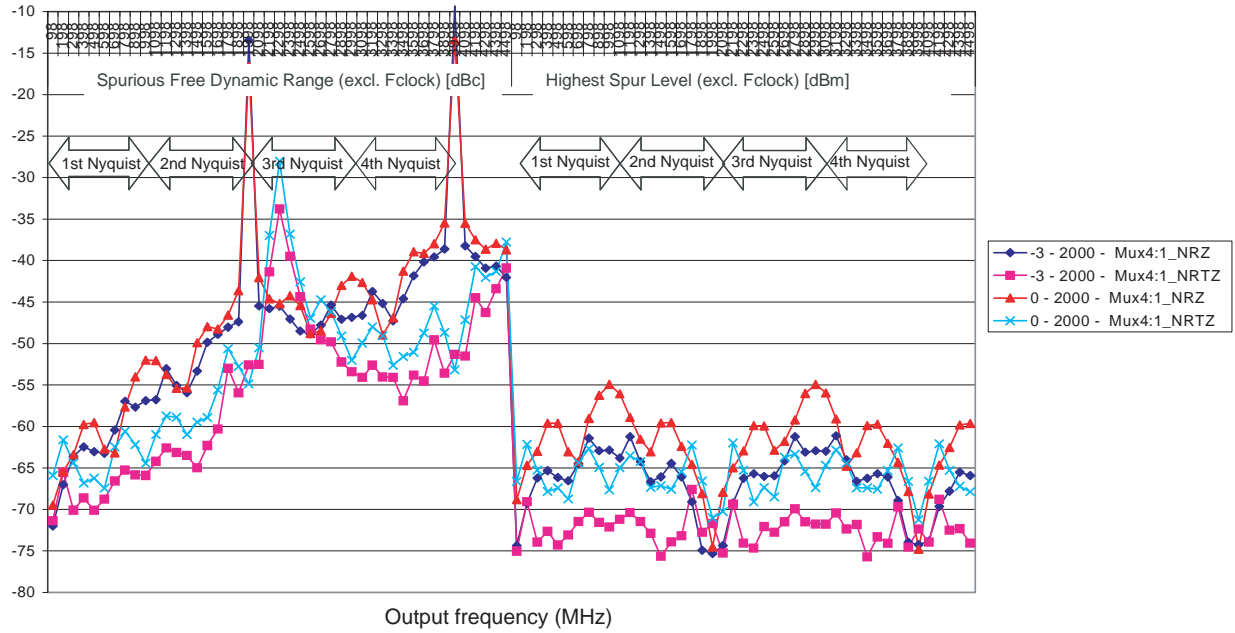

NRTZ linearity is slightly improved reducing the sampling rate to 2000 MSps, possibility of operation over the 4th Nyquist zone is demonstrated.

Figure 7-20. Comparison of NTRZ and RTZ Modes at Full Scale and -3 dBFS at 2000 MSps: SFDR and HSL (Excluding Fclock)

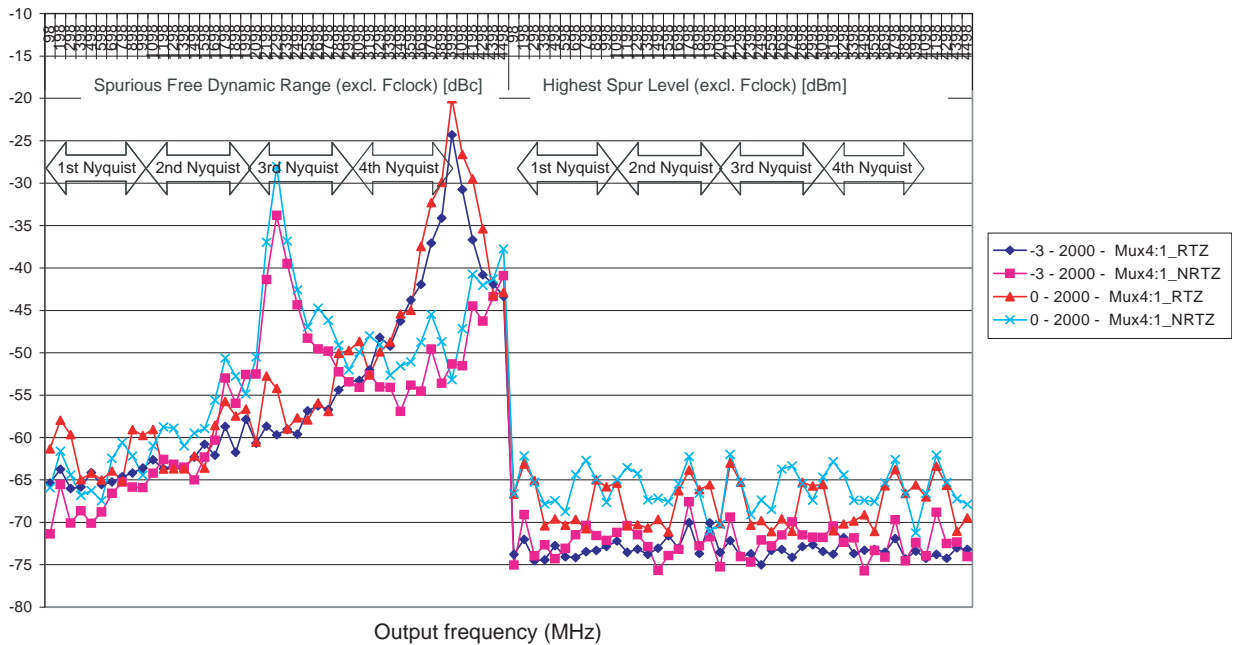

NTRZ mode is relevant in 1st, 2nd Nyquist zones and is still usable over 4th Nyquist zone with SFDR in excess of 50 dBc.

7.2.3 Single tone measurements: typical spectra at 3Gbps

The following figures show typical SFDR spectra obtained for the four DAC modes on an EV12DS130A/B device.

Conditions: typical power supplies, ambient temperature, MUX4:1, $F_s = 3$ Gbps.

Figure 7-21. Typical SFDR spectrum in NRZ mode. $F_{out} = 100$ MHz (1st Nyquist), MUX4:1, $F_s = 3$ Gbps. SFDR = 67dBc

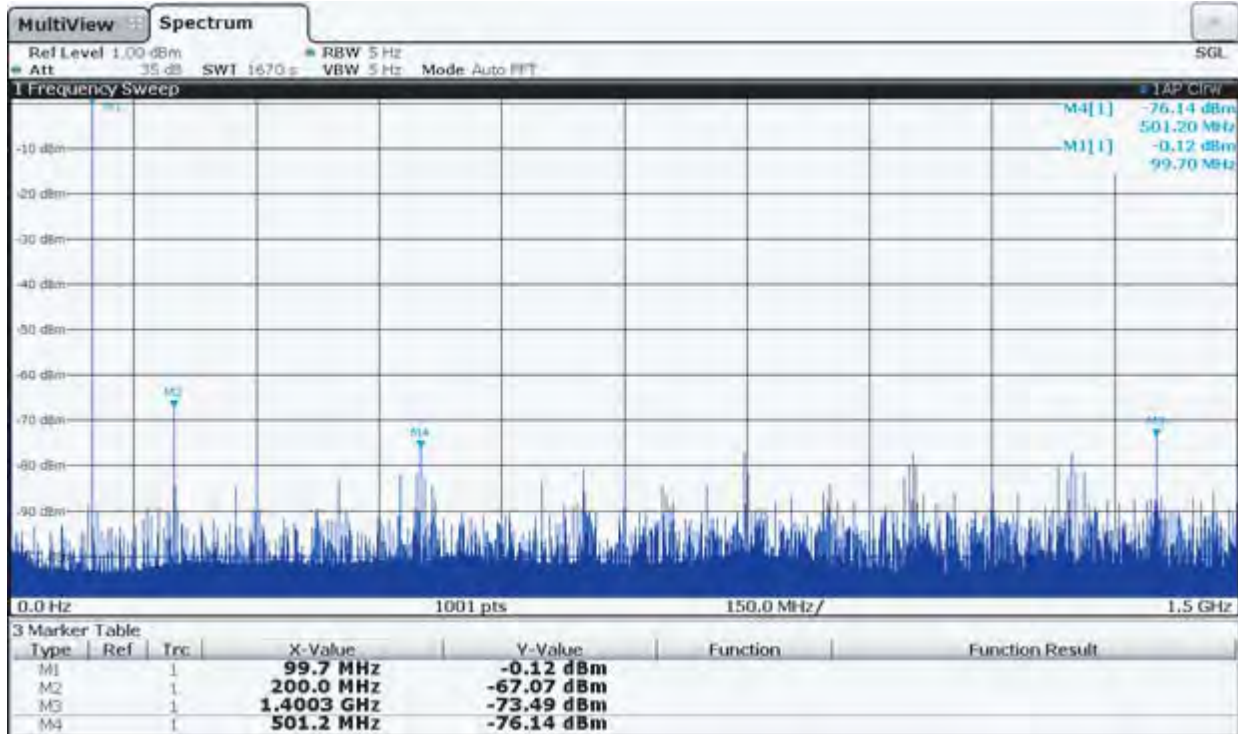

Figure 7-22. Typical SFDR spectrum in NRTZ mode. $F_{out} = 1800\text{MHz}$ (2nd Nyquist), MUX4:1, $F_s = 3\text{Gps}$. SFDR = 61dBc



Figure 7-23. Typical SFDR spectrum in RTZ mode. $f_{out} = 2900\text{MHz}$ (2nd Nyquist), MUX4:1, $F_s = 3\text{Gps}$. SFDR = 59dBc.

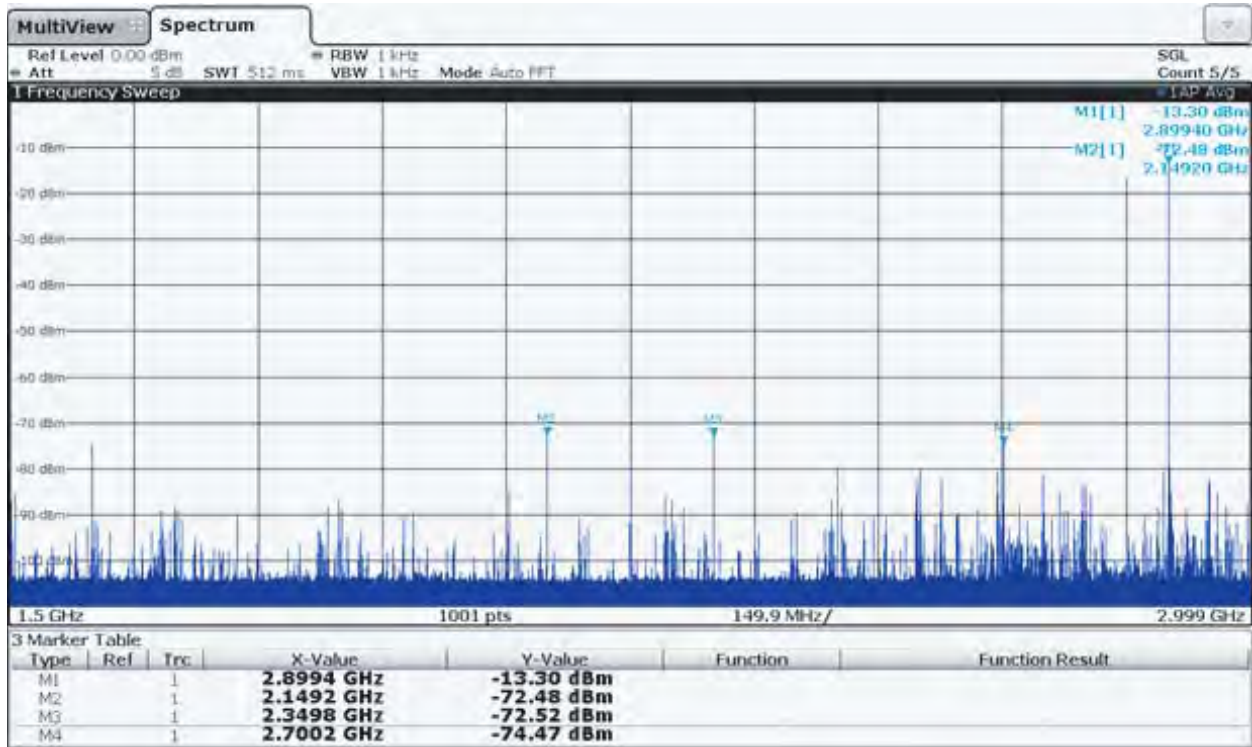
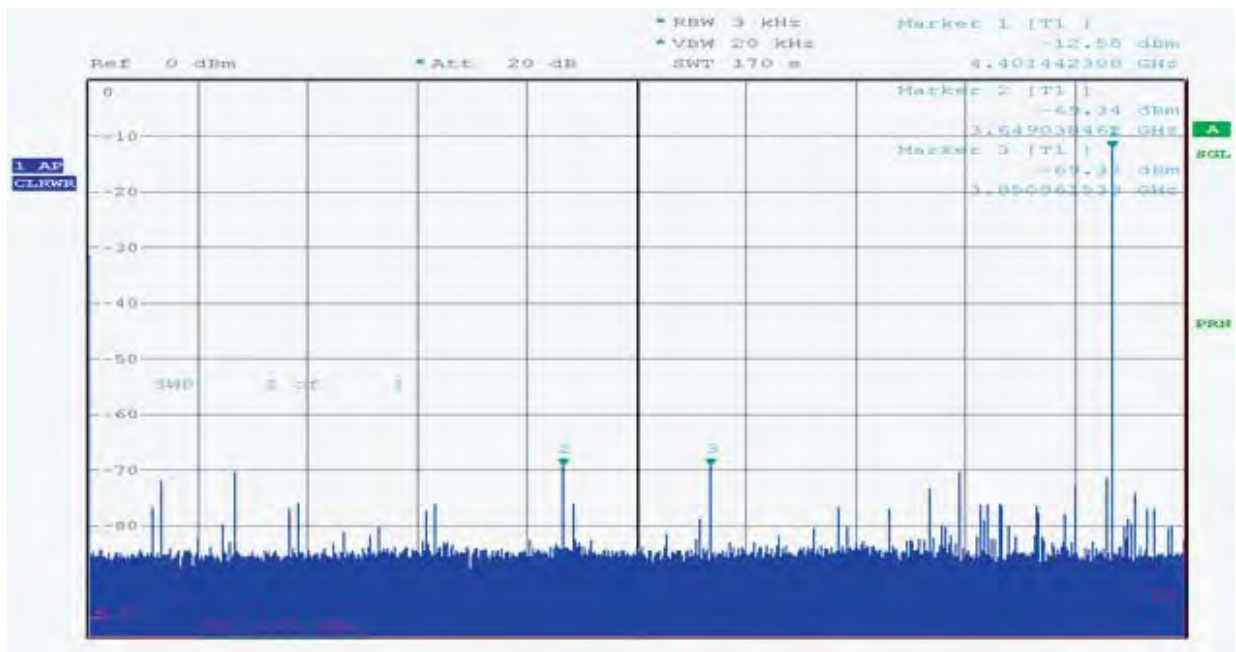

Figure 7-24. Typical SFDR spectrum in RF mode. $f_{out} = 4400\text{MHz}$ (3rd Nyquist), MUX4:1, $F_s = 3\text{Gps}$. SFDR = 56 dBc



7.2.4 Multi Tone Measurements

A five tones pattern (400 MHz, 500 MHz, 600 MHz, 700 MHz and 800 MHz) is applied to the DAC operating at 3 Gps and results are observed in the 2nd, 3rd, 4th and 5th Nyquist zones.

Results are given in the most relevant mode considering the Nyquist zone observed.

Figure 7-25. Observation of the 2nd Nyquist Zone (Tones are pushed from 2.2 GHz to 2.6 GHz): NRTZ, RF and RTZ Modes

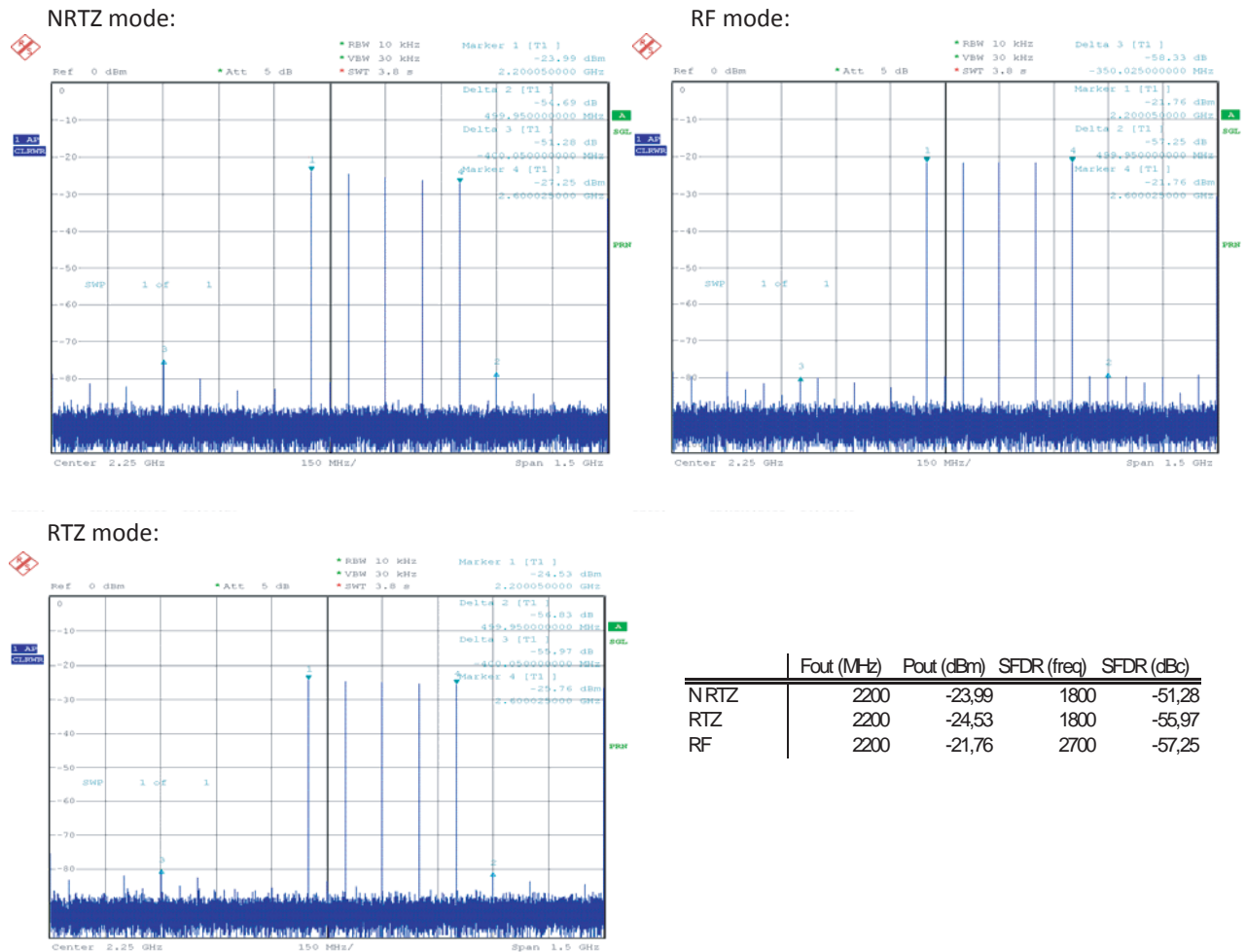
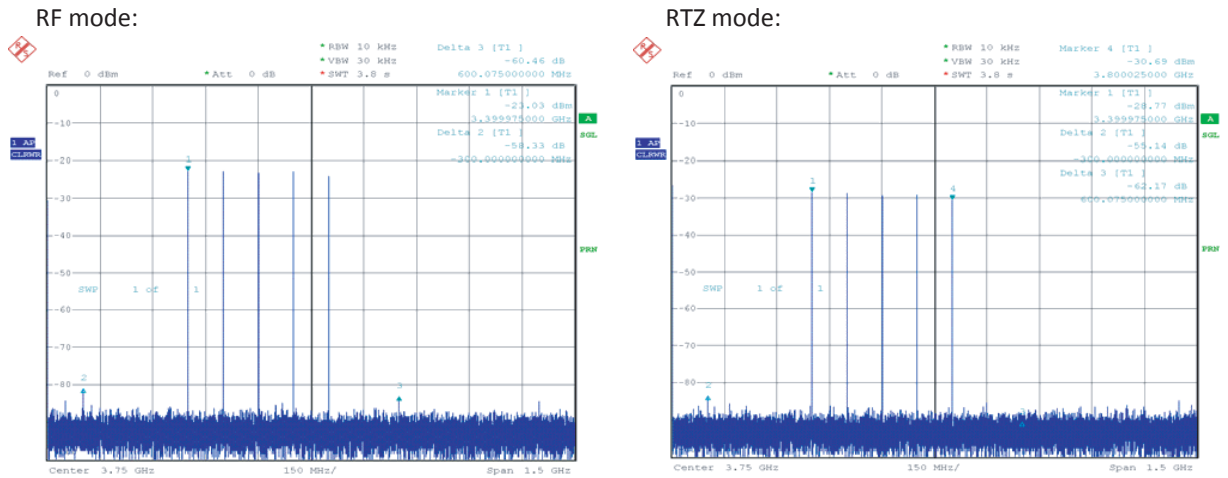

Figure 7-26. Observation of the 3rd Nyquist Zone (Tones are pushed from 3.4GHz to 3.8GHz): RF and RTZ Modes



	Fout (MHz)	Pout (dBm)	SFDR (freq)	SFDR (dBc)
NRTZ	3400	-39.43	4000	-44.48
RTZ	3400	-28.77	3100	-55.14
RF	3400	-23.03	3100	-58.33

NRTZ performances are degraded because of the sinc attenuation (first notch in the first half of the 3rd Nyquist zone).

Figure 7-27. Observation of the 4th Nyquist Zone (Tones are pushed from 5.2 GHz to 5.6 GHz): NRTZ and RF Modes

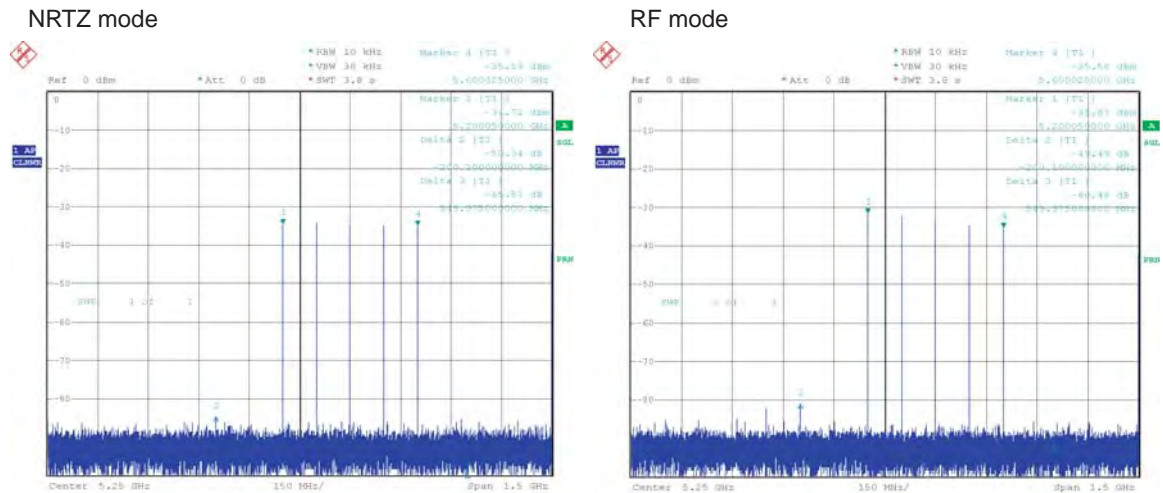

	Fout (MHz)	Pout (dBm)	SFDR (freq)	SFDR (dBc)
NRTZ	5200	-34.72	5000	-50.34
RTZ	5200	-40.37	4700	-45
RF	5200	-31.87	4700	-49.49

RTZ mode is degraded because of the sinc attenuation (first notch at the end of the 4th Nyquist zone). RF mode offers significantly more power than RTZ mode, this is why we still have acceptable performances.

NRTZ operation is possible because the 4th Nyquist zone is fully included in the secondary spectral lobe.

Figure 7-28. Observation of the 5th Nyquist Zone (Tones are pushed from 6.4 GHz to 6.8 GHz): NRTZ Mode

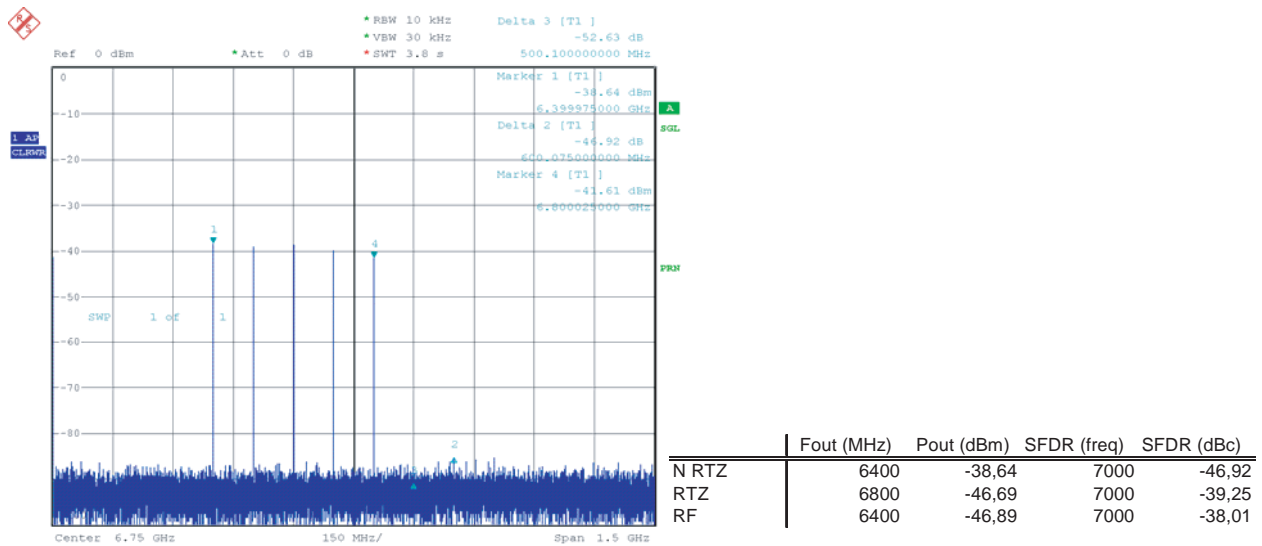

NRTZ mode is still usable in the 5th Nyquist zone (SFDR in excess of 46 dB).

7.2.5 Direct Microwave Synthesis Capability Measurements: ACPR

Measurements given hereafter are performed on the DAC at 3 Gps with a 10 MHz wide QPSK pattern centered on 800 MHz.

Results are observed in 2nd, 3rd, 4th and 5th Nyquist zones and are given only for the most relevant modes (that is RF and/or NRTZ modes).

Figure 7-29. NRTZ Mode, 2nd Nyquist: Center Frequency is pushed to 3 GHz – 800 MHz = 2.2 GHz

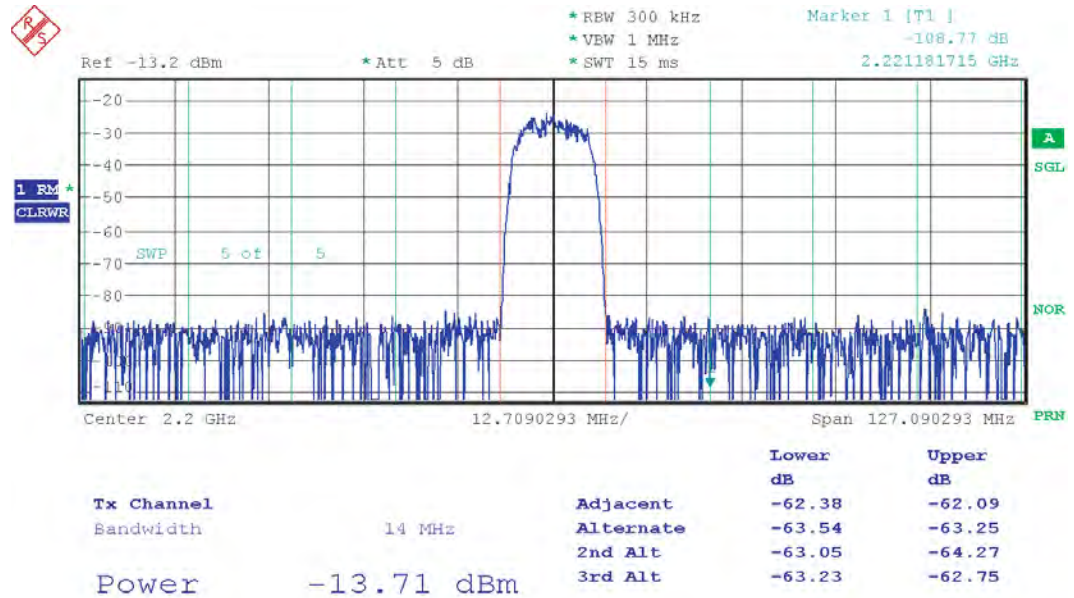

ACPR is in excess of 62 dB. DMWS capability is proven for second Nyquist in NRTZ mode.

Figure 7-30. RF Mode, 2nd Nyquist: Center Frequency is pushed to 3 GHz – 800 MHz = 2.2 GHz

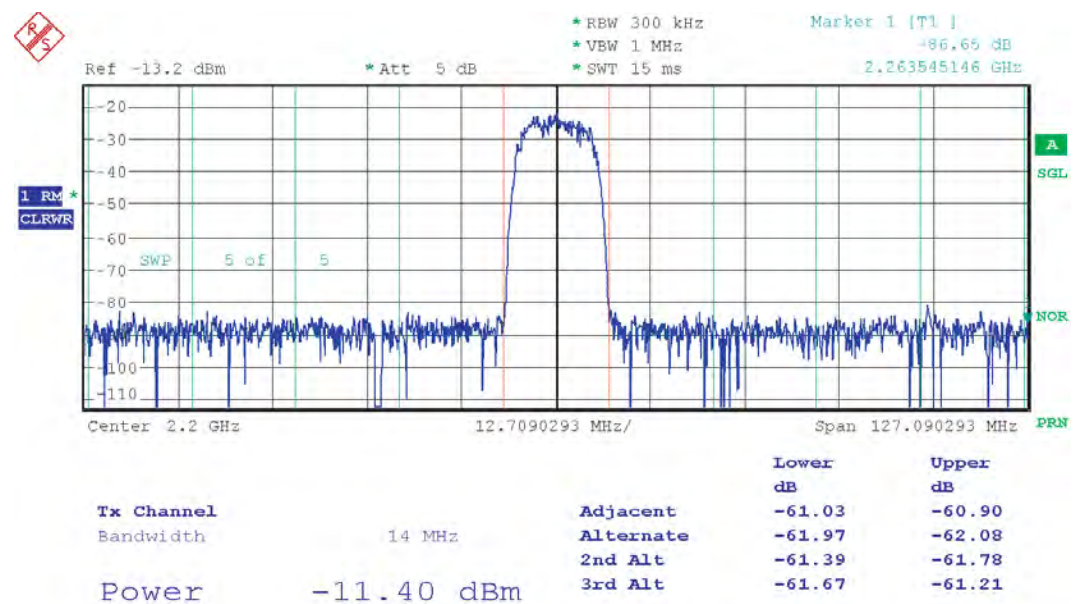

ACPR is in excess of 60 dB. DMWS capability is proven for the second Nyquist zone in RF mode with slightly reduced dynamic range regarding NRTZ mode but with increased output power.

Figure 7-31. RF Mode, 3rd Nyquist Zone: Center Frequency is pushed to 3 GHz+ 800 MHz = 3.8 GHz

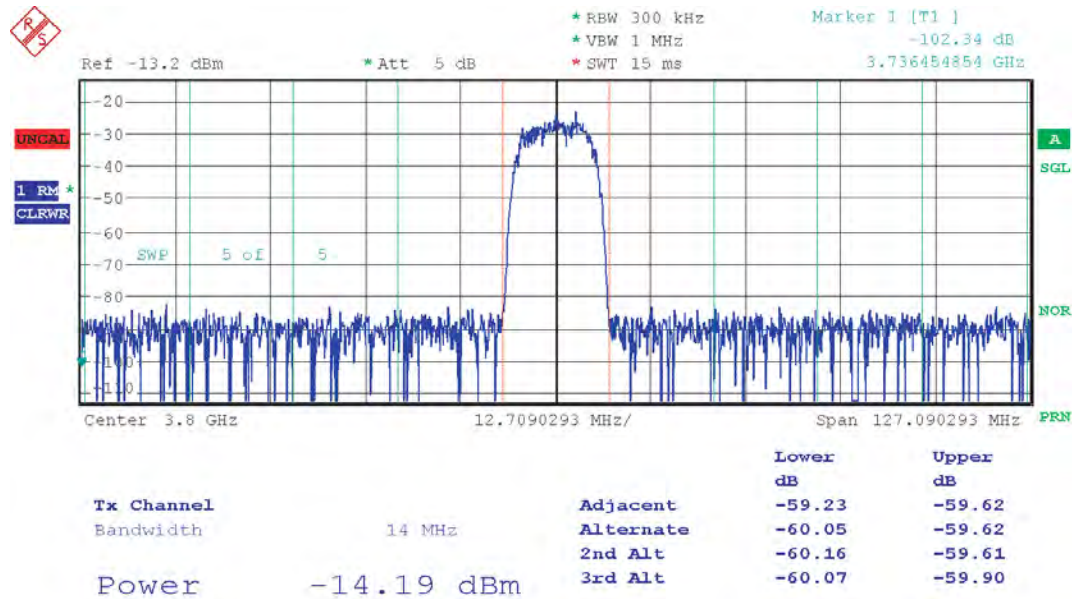

ACPR is in excess of 59 dB. DMWS capability is proven for the third Nyquist zone in RF mode.

Note: due to the notch of available Pout near the middle of the third Nyquist zone, the NRTZ mode is not relevant for DMWS in the third Nyquist zone.

Figure 7-32. NRTZ Mode, 4th Nyquist Zone: Center Frequency is pushed to 6 GHz – 800 MHz = 5.2 GHz

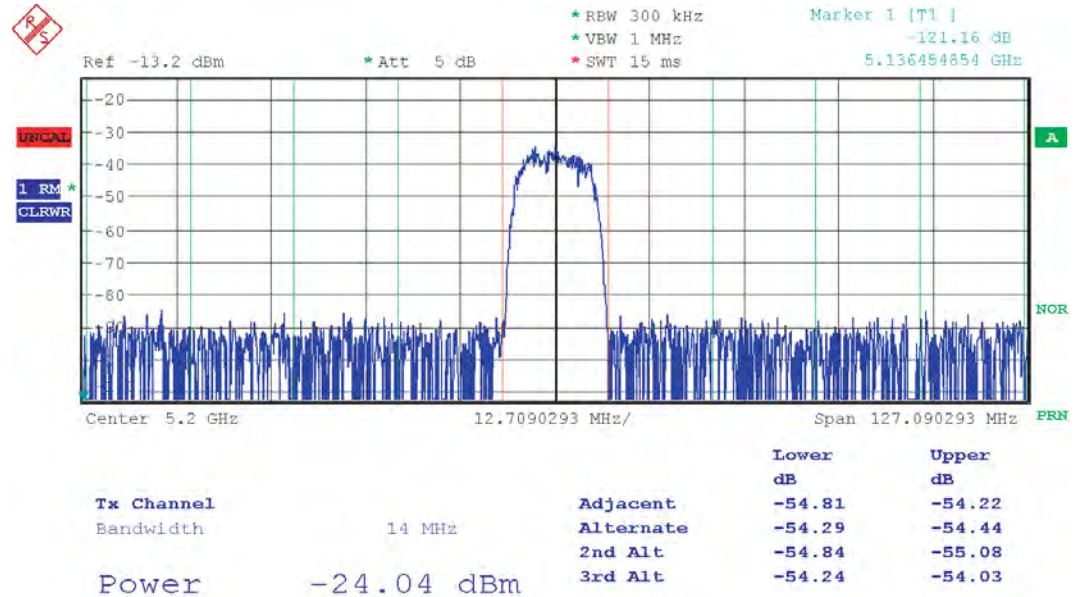

ACPR is in excess of 54 dB. DMWS capability is proven for the fourth Nyquist zone in NRTZ mode.

Figure 7-33. RF Mode, 4th Nyquist Zone: Center Frequency is pushed to 6 GHz – 800 MHz = 5.2 GHz

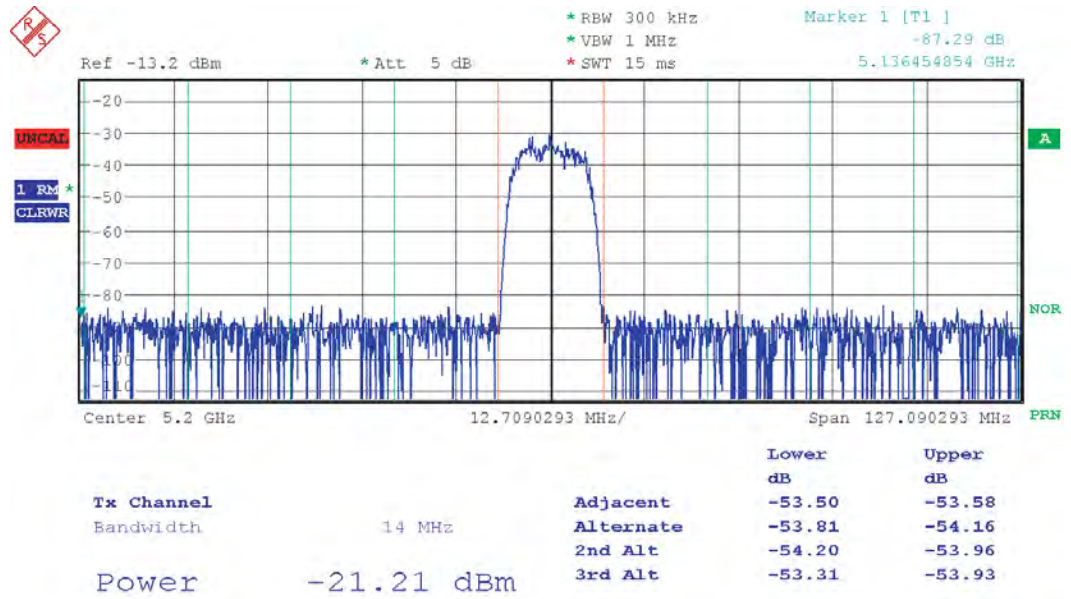

ACPR is in excess of 53 dB. DMWS capability is proven for the fourth Nyquist zone in RF mode.

Note due to a notch of available Pout near the end of the 4th Nyquist zone in RF output mode, for DMWS beyond middle of 4th Nyquist zone it is recommended to use the NRTZ output mode instead of the RF output mode.

Figure 7-34. NRTZ Mode, 5th Nyquist Zone: Center Frequency is pushed to 6 GHz + 800 MHz = 6.8 GHz

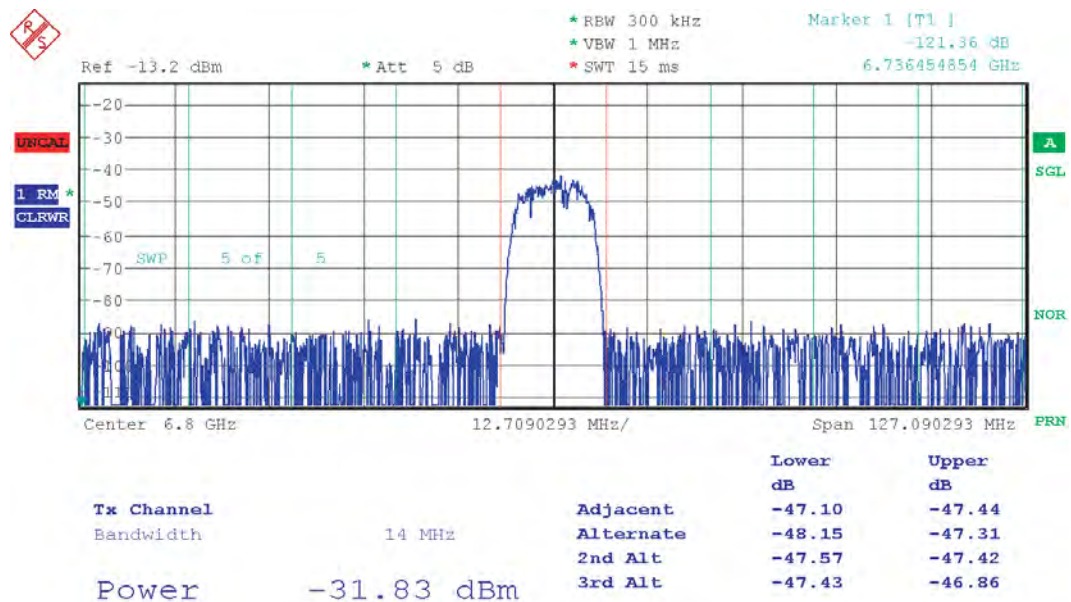

ACPR is still in excess of 47 dB. DMWS capability if proven for the fifth Nyquist zone in NRTZ mode with reduced available dynamic range.

7.2.6 DOCSIS v3.0 Capability Measurements

Measurements hereafter have been carried out on a soldered device EV12DS130A/B, in NRTZ mode at 3 GSps.

Note: Results illustrated hereafter (spectrum and zoom on notch) come from measurement on a EV12DS130A/B device (CI-CGA255 package). Measurements have been carried out using the ACP treatment of the spectrum analyzer Rhode & Schwarz FSU8, in RMS detection mode.

Figure 7-35. ACPR 1 Channel Centered on 300 MHz, Output Mode NRTZ

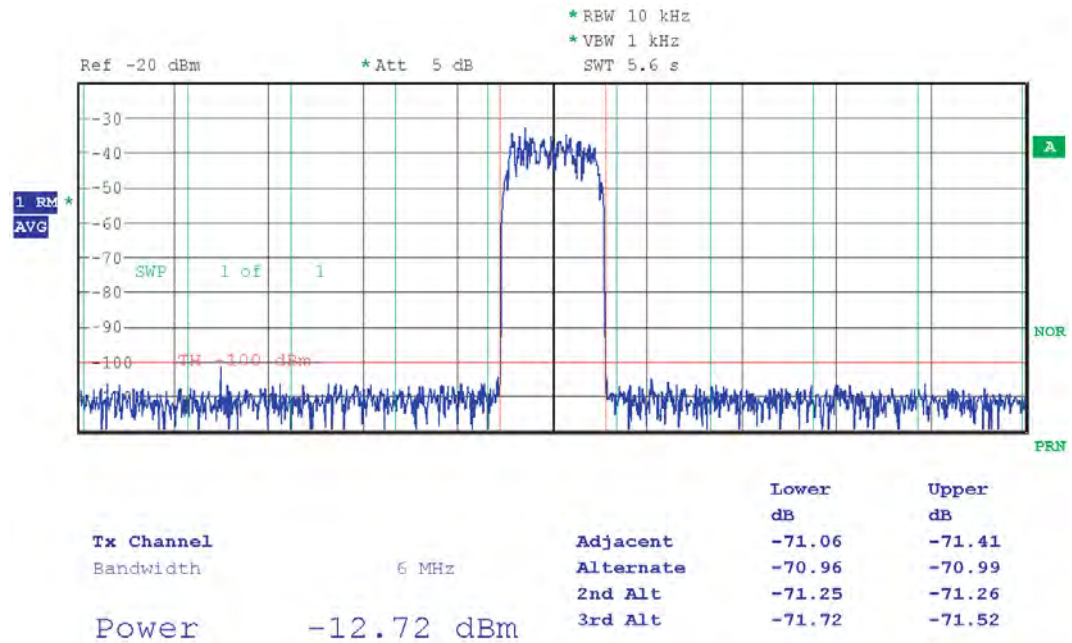

Figure 7-36. ACPR 1 Channel Centered on 900 MHz, Output Mode NRTZ

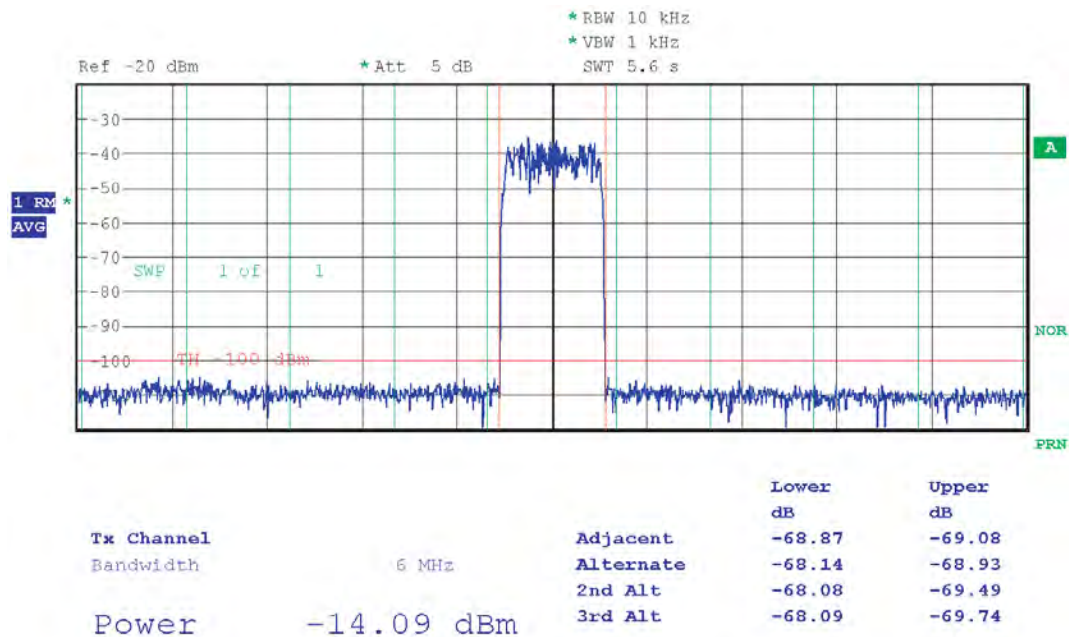

Figure 7-37. ACPR 1 channel centered on 300 MHz, Output Mode NRTZ

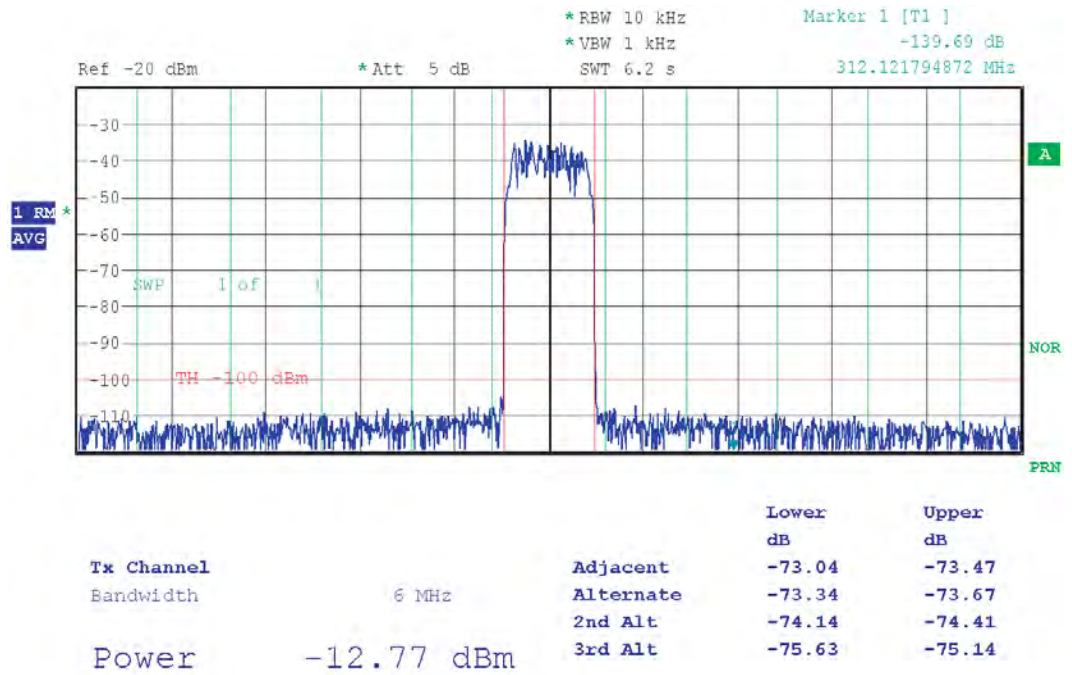

Figure 7-38. ACPR 4 Channels Centered on 300 MHz, Output Mode NRTZ

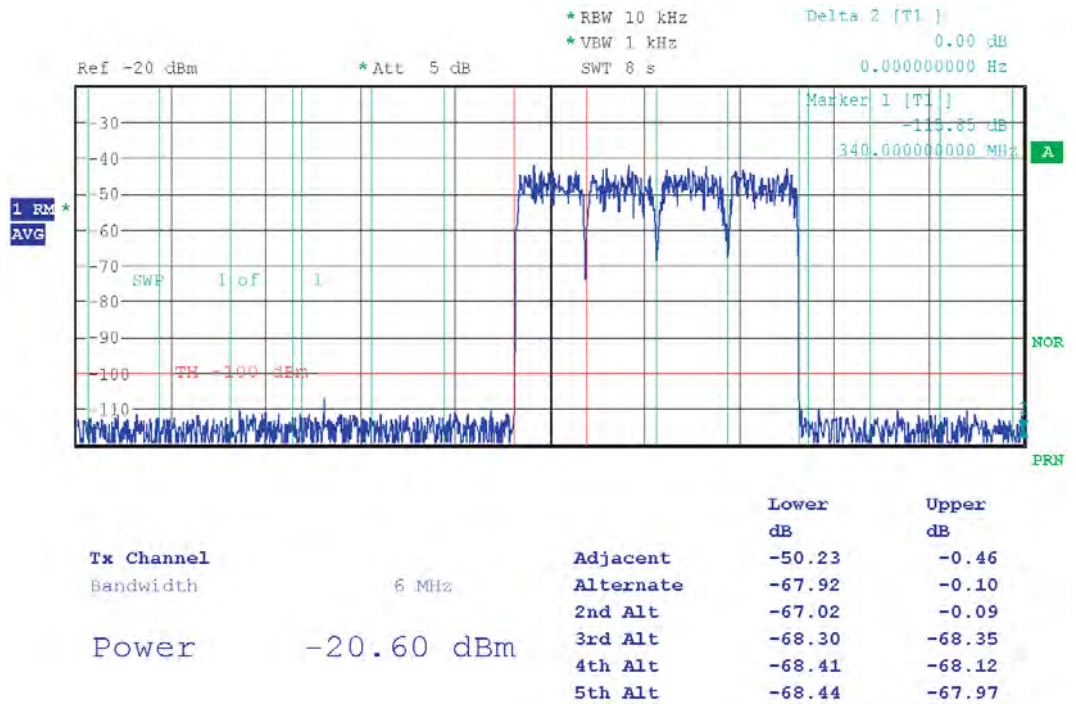

Figure 7-39. ACPR 1 Channel Centered on 900 MHz, Output Mode NRTZ

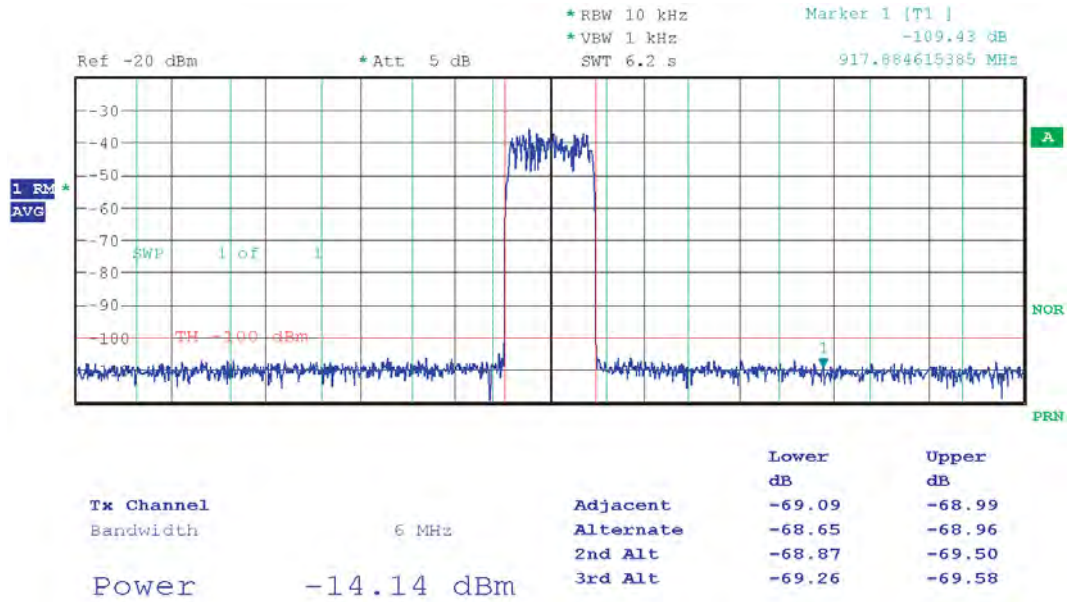
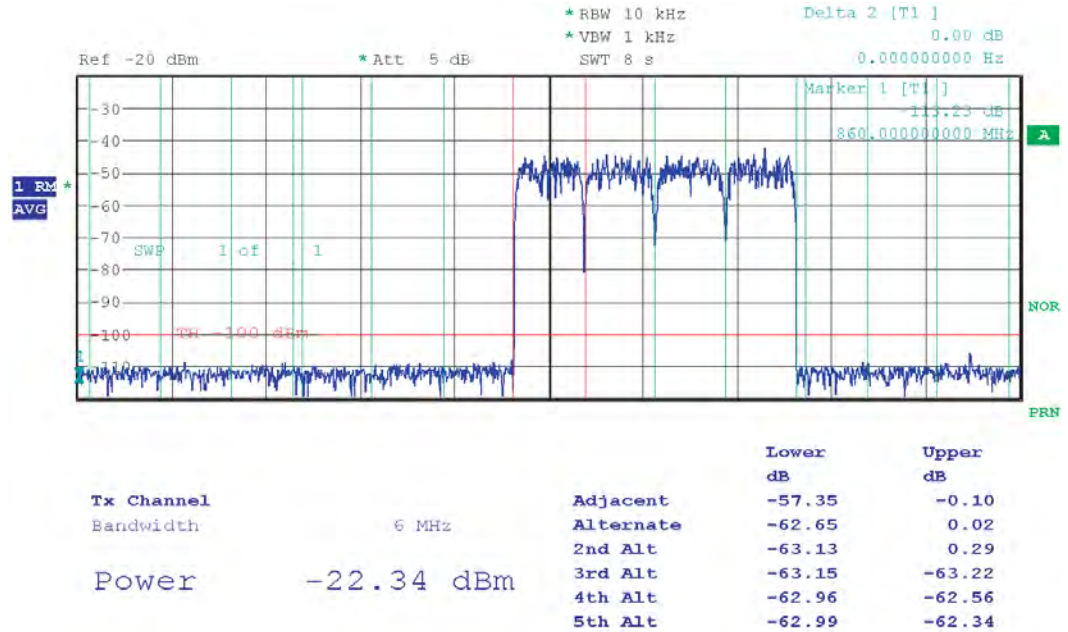

Figure 7-40. ACPR 4 Channels Centered on 900 MHz, Output Mode NRTZ



7.2.7 NPR Performance

NPR measurements have been carried out at optimum loading factor (LF) for a 12 bit DAC, that is – 14 dBFS, with the DAC operating at 3 Gbps.

SNR can be computed from SNR measurement with the formula: $SNR_{[dB]} = NPR_{[dB]} + ILF_{[dB]} - 3$.

ENOB can be computed with the formula: $ENOB = (SNR_{[dB]} - 1.76) / 6.02$.

Note: Results illustrated hereafter (spectrum and zoom on notch) come from measurement on a EV12DS130A/B device (CI-CGA255 package). Measurements have been carried out using the ACP treatment of the spectrum analyzer Rhode & Schwarz FSU8, in RMS detection mode.

Figure 7-41. NPR in First Nyquist Zone, 20 MHz to 900 MHz Noise Pattern with a 25 MHz Notch Centered on 450 MHz, NRZ mode

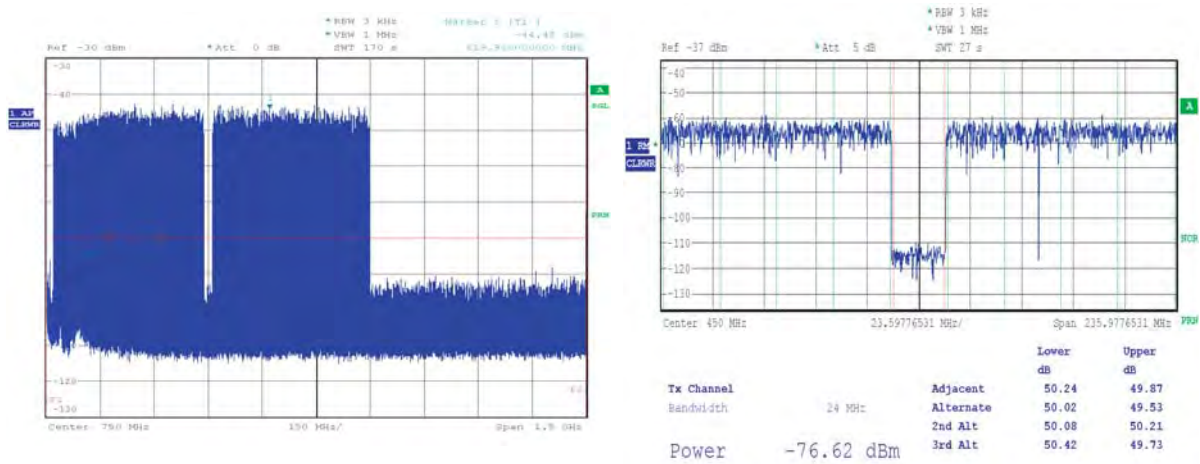

Measured average NPR: 50.02 dB, therefore SNR = 61.02 dB and ENOB = 9.84 bit

Effects at low frequency are due to balun and pattern.

Figure 7-42. NPR in First Nyquist Zone, 20 MHz to 900 MHz Noise Pattern with a 25 MHz Notch Centered on 450 MHz, NRTZ Mode

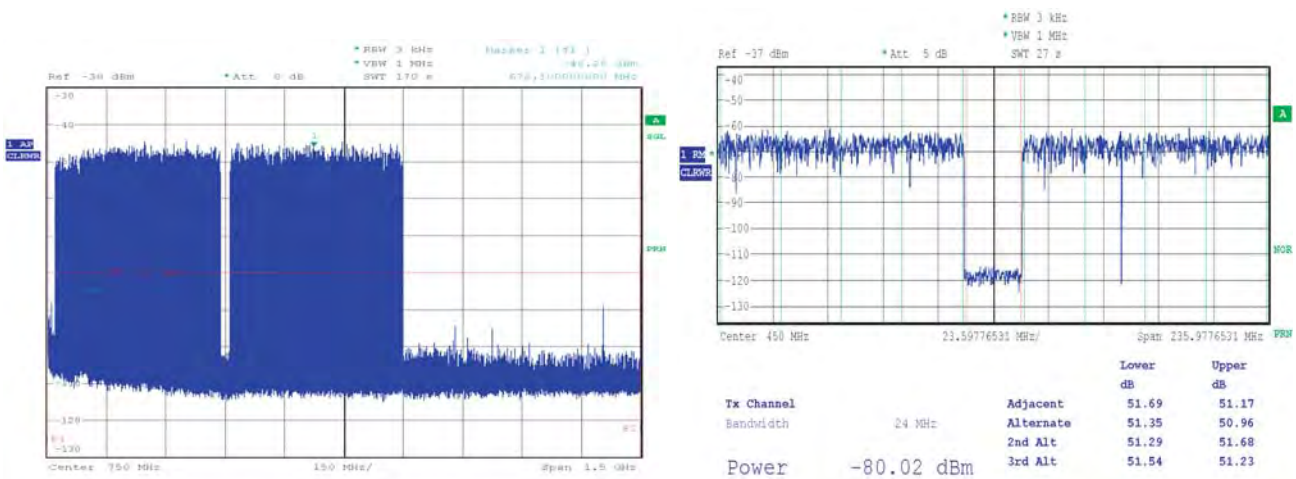

Measured average NPR: 51.36 dB, therefore SNR = 62.36 dB and ENOB = 10.07 bit.

Effects at low frequency are due to balun and pattern.

Figure 7-43. NPR in First Nyquist Zone, 10 MHz to 450 MHz Noise Pattern with a 12.5 MHz Notch centered on 225 MHz, NRTZ Mode at $F_s = 1.5$ Gps

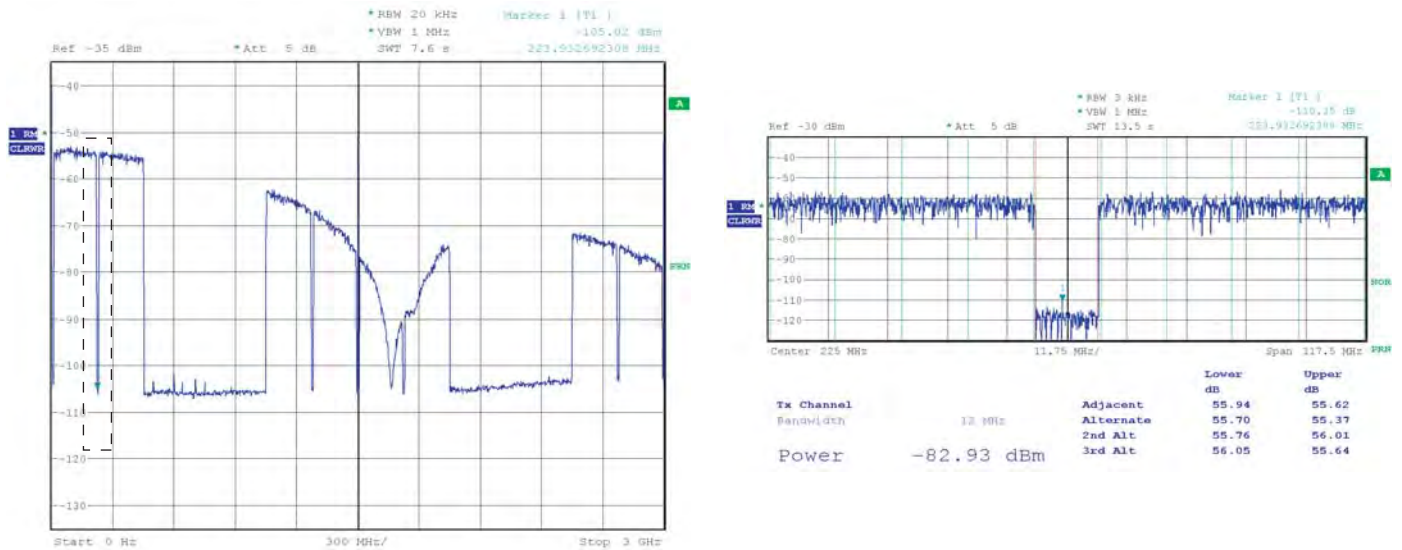

Measured average NPR: 55.7 dB, therefore SNR = 66.7 dB and ENOB = 10.8 bit.

Effects at low frequency are due to balun and pattern.

Figure 7-44. NPR in second Nyquist Zone, 1520 MHz to 2200 MHz Noise Pattern with a 25 MHz Notch centered on 1850 MHz, RTZ mode

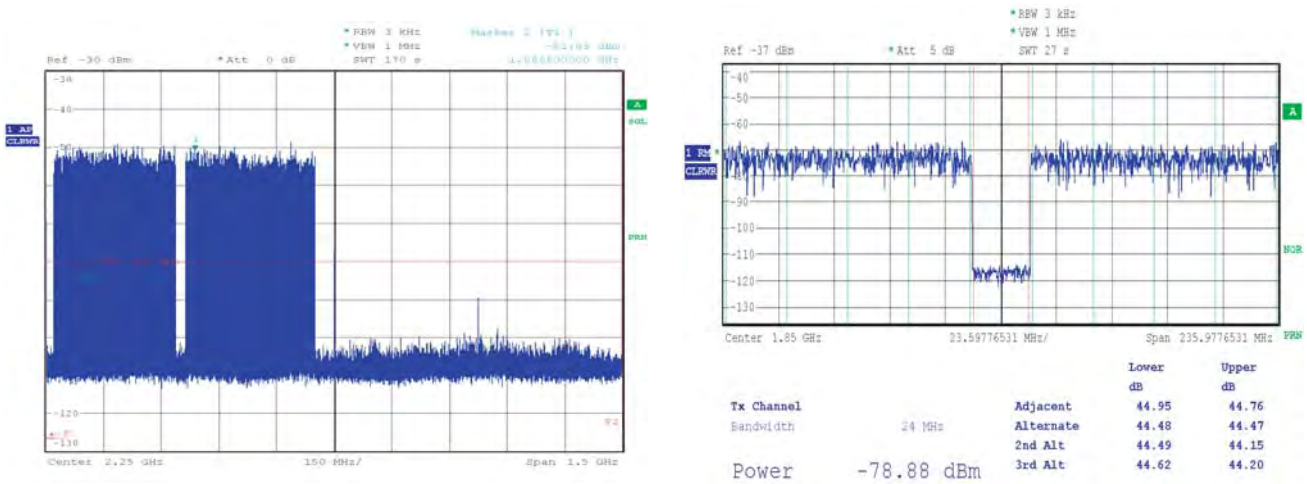

Measured average NPR: 44.6 dB, therefore SNR = 55.6 dB and ENOB = 8.94 bit

Figure 7-45. NPR in second Nyquist Zone, 1520 MHz to 2200 MHz noise pattern with a 25 MHz notch centered on 1850 MHz, RF Mode

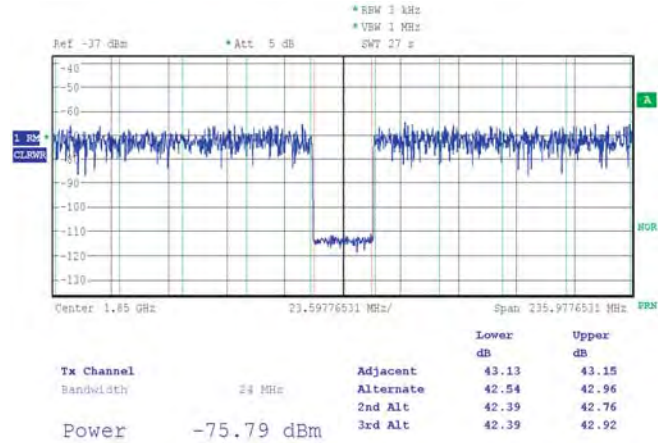
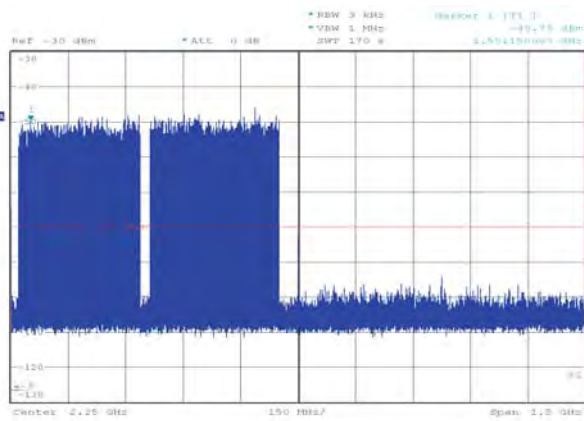

Measured average NPR: 42.78 dB, therefore SNR = 53.78 dB and ENOB = 8.64 bit

Figure 7-46. NPR in second Nyquist Zone, 2200 MHz to 2880 MHz Noise Pattern with a 25 MHz Notch centered on 2550 MHz, RF Mode

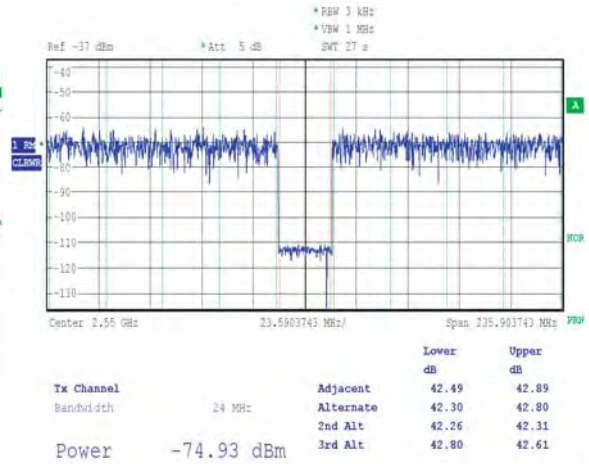
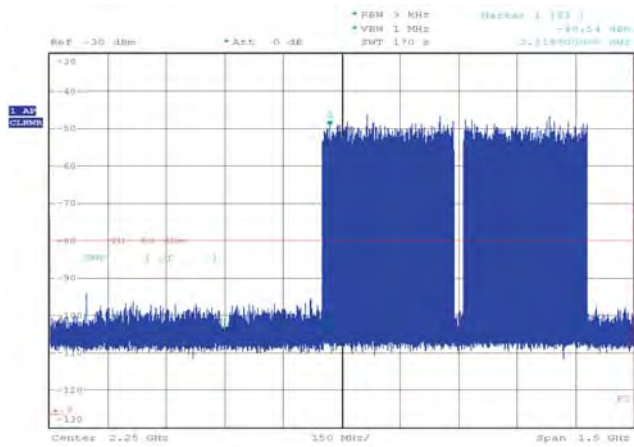

Measured average NPR: 42.56 dB, therefore SNR = 53.56 dB and ENOB = 8.6 bit.

Figure 7-47. NPR in Third Nyquist Zone, 3050 MHz to 3700 MHz Noise Pattern with a 25 MHz Notch Centered on 3375 MHz, RF Mode

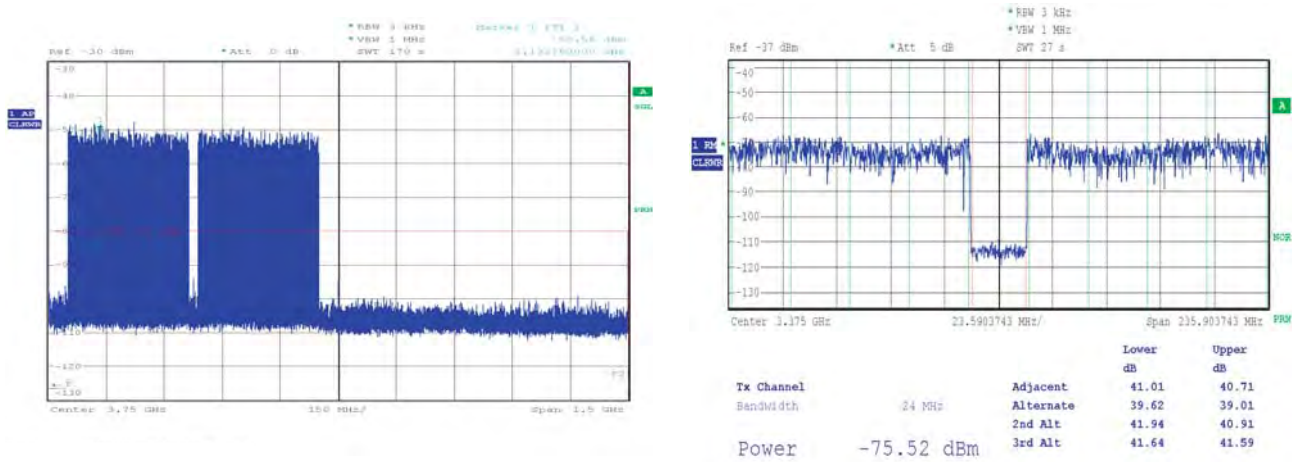

Measured average NPR: 40.08 dB, therefore SNR = 51.08 dB and ENOB = 8.19 bit

The following figures reflect the stability of NPR in first Nyquist in NRTZ mode (and therefore SNR and ENOB) versus temperature.

Measurements have been carried out at nominal power supply on an EV12DS130A/B, at 3 Gbps, with the FSU8 spectrum analyzer in RMS detection mode.

Figure 7-48. Drift of NPR and Associated SNR and ENOB in First Nyquist in NRTZ Mode from $T_j = -30^\circ\text{C}$ to $T_j = 125^\circ\text{C}$

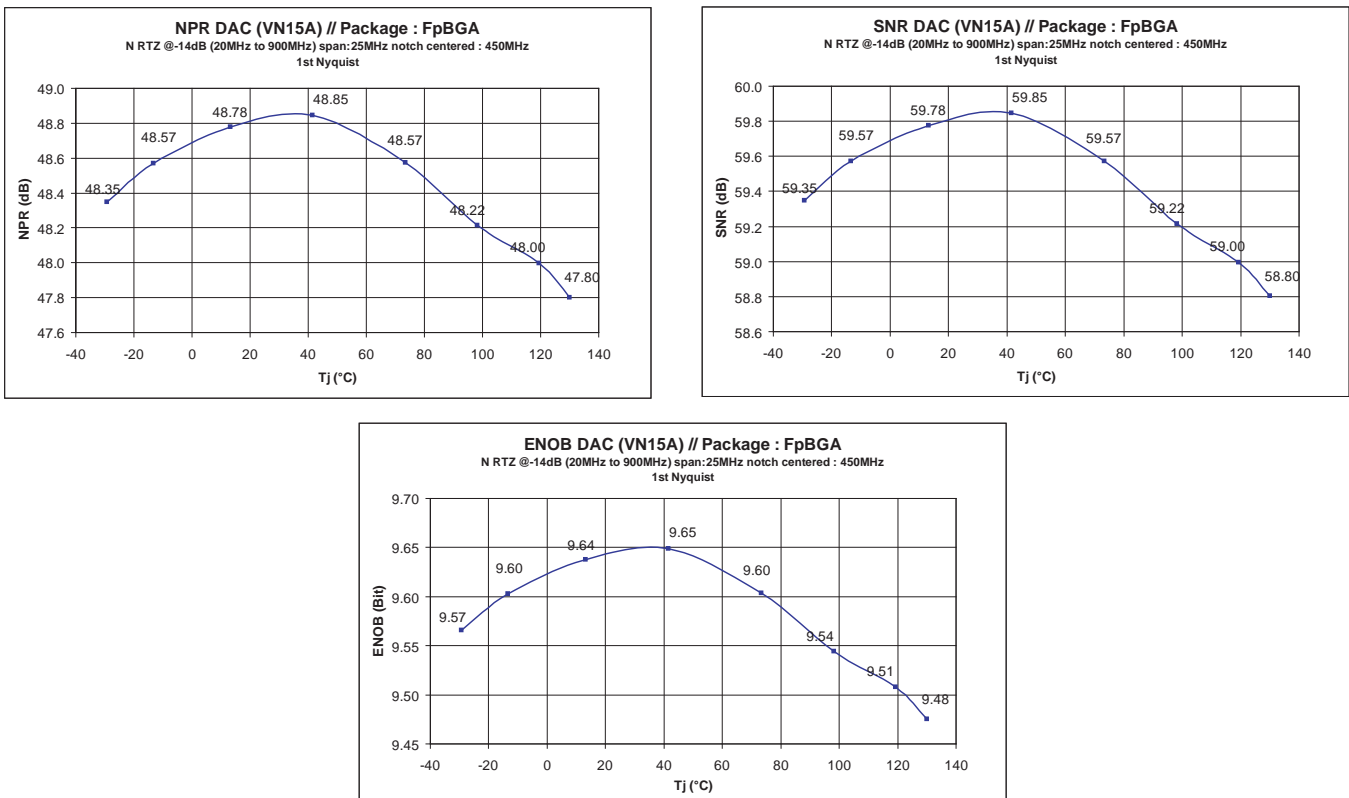

Optimum is at $T_j = 40^\circ\text{C}$, degradation over temp is within 1 dB (or 0.15 effective bit).

Measurements hereafter have been carried out on an EV12AS130AGS device at 3 Gbps, with the FSU8 spectrum analyzer in RMS detection mode.

Figure 7-49. Drift of NPR vs temperature in the 4 Output Modes at Nominal Supply

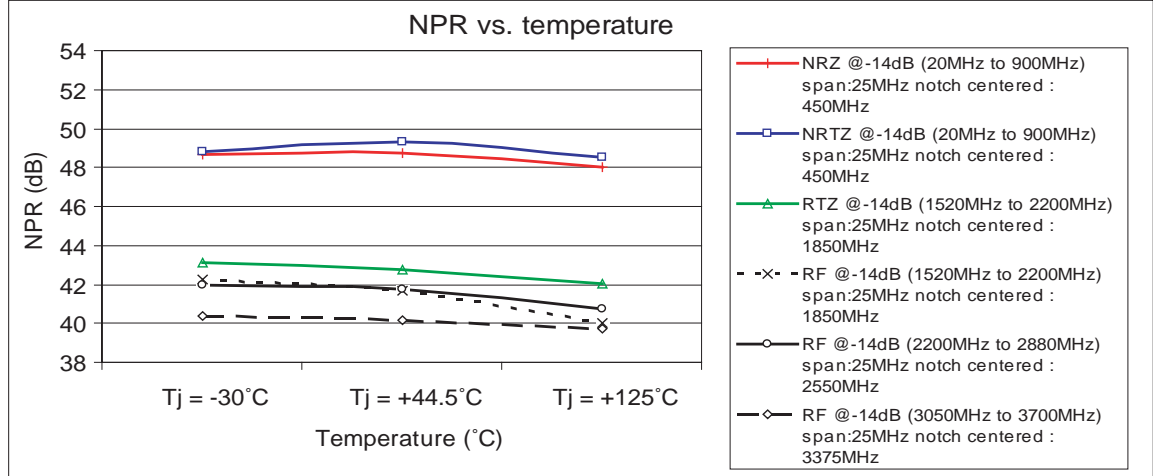

Conclusion: performances are stable in the four output modes against temperature.

Figure 7-50. NPR vs Power Supply Level in the 4 Output Modes at Room Temperature

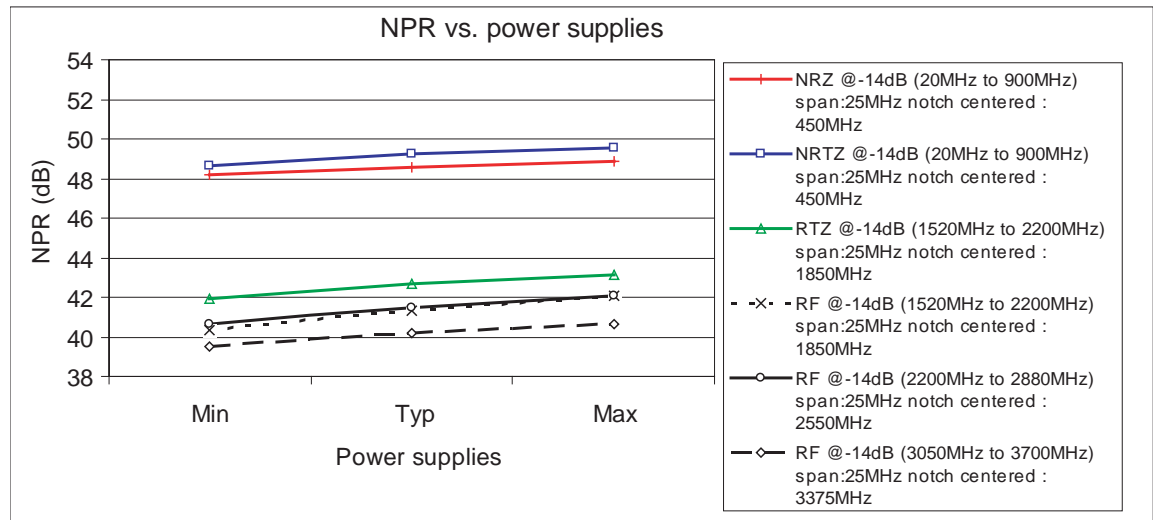

Conditions: Typical, excepted: power supplies

Min: $V_{CCA}: 4.75\text{V} // V_{CCA3} = V_{CCD} = 3.15\text{V}$

Typ: $V_{CCA}: 5.0\text{V} // V_{CCA3} = V_{CCD} = 3.3\text{V}$

Max: $V_{CCA}: 5.25\text{V} // V_{CCA3} = V_{CCD} = 3.45\text{V}$.

Conclusion: performances are fairly stable against power supply.

Note: NPR performance at lower clock frequencies is affected by power up sequence. See application note 1087 for further details.

7.2.8 Spectrum over 4 Nyquist Zones in the Four Output Modes

Observation of a 1GHz broadband pattern with a 25 MHz notch centered on 500 MHz spectrum over 4 Nyquist zones at 3 Gsps (that is from DC to 6 GHz), measurements performed on an EV12DS130A/B device (CI-CGA 255 package, with an overall 6 GHz bandwidth limitation).

By periodisation of a sampled system each tone F_i of the pattern in the 1st Nyquist zone is duplicated as follows:

- 2nd Nyquist Zone: tone at $F_{clock} - F_i$
- 3rd Nyquist Zone: tone at $F_{clock} + F_i$
- 4th Nyquist Zone: tone at $2 * F_{clock} - F_i$

Figure 7-51. Spectrum over 4 Nyquist Zones at 3 Gsps in NRZ Output Mode

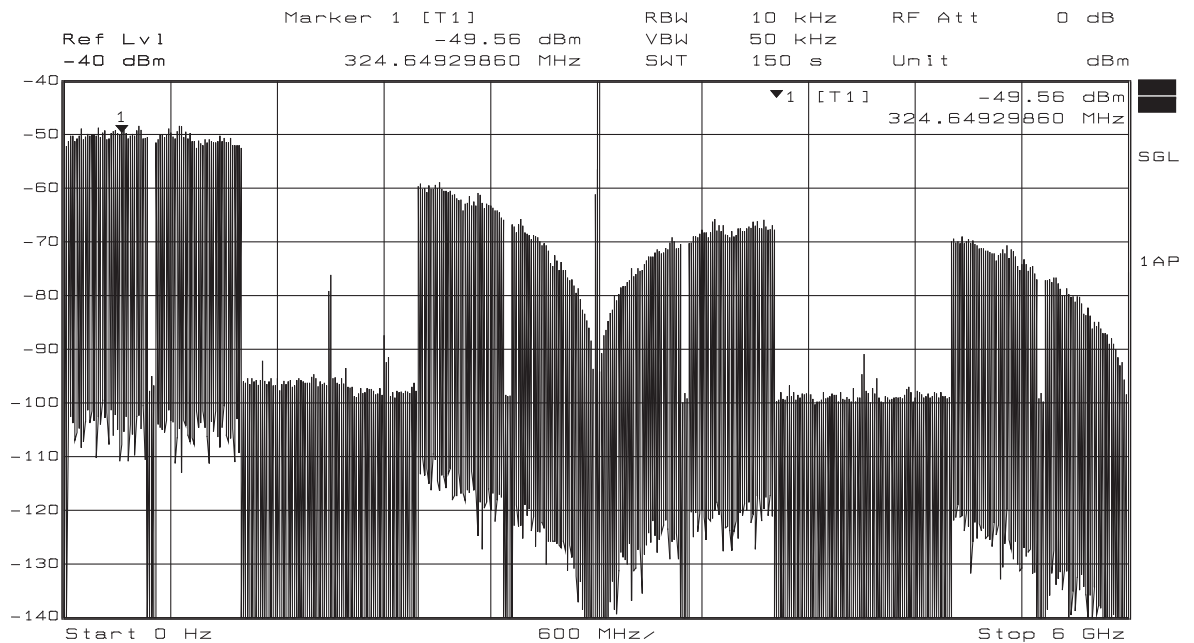

First Zero of the sinc() function is at F_{clock} .

Figure 7-52. Spectrum over 4 Nyquist Zones at 3 Gps in NRTZ Output Mode

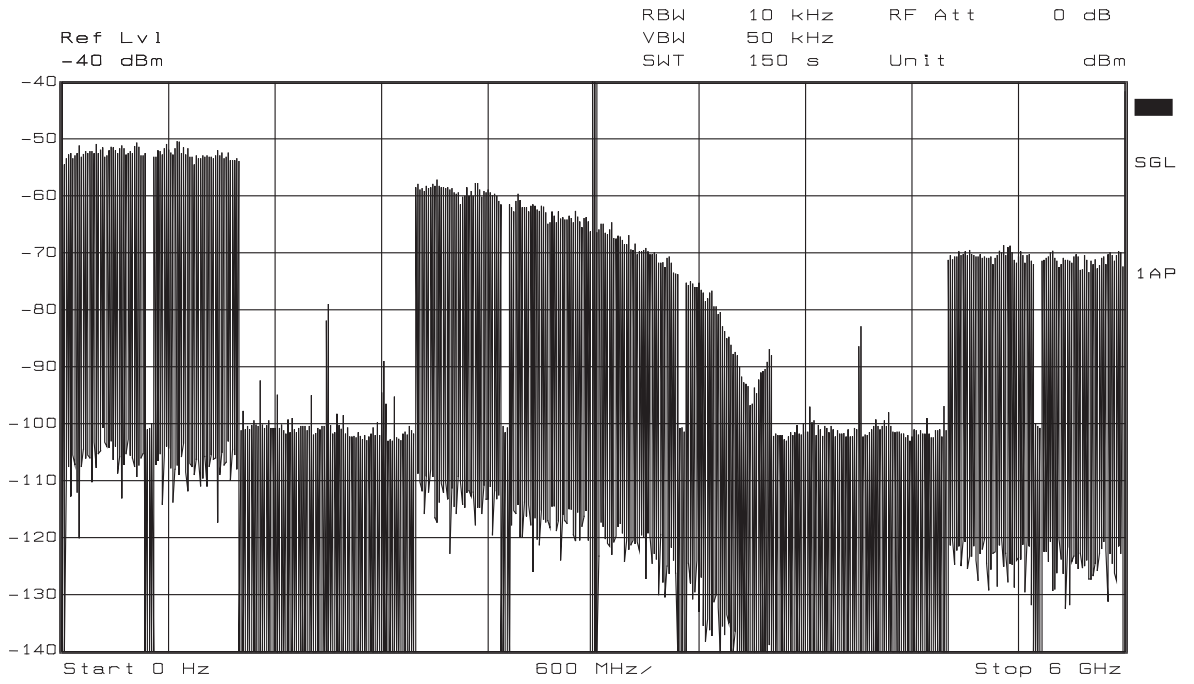
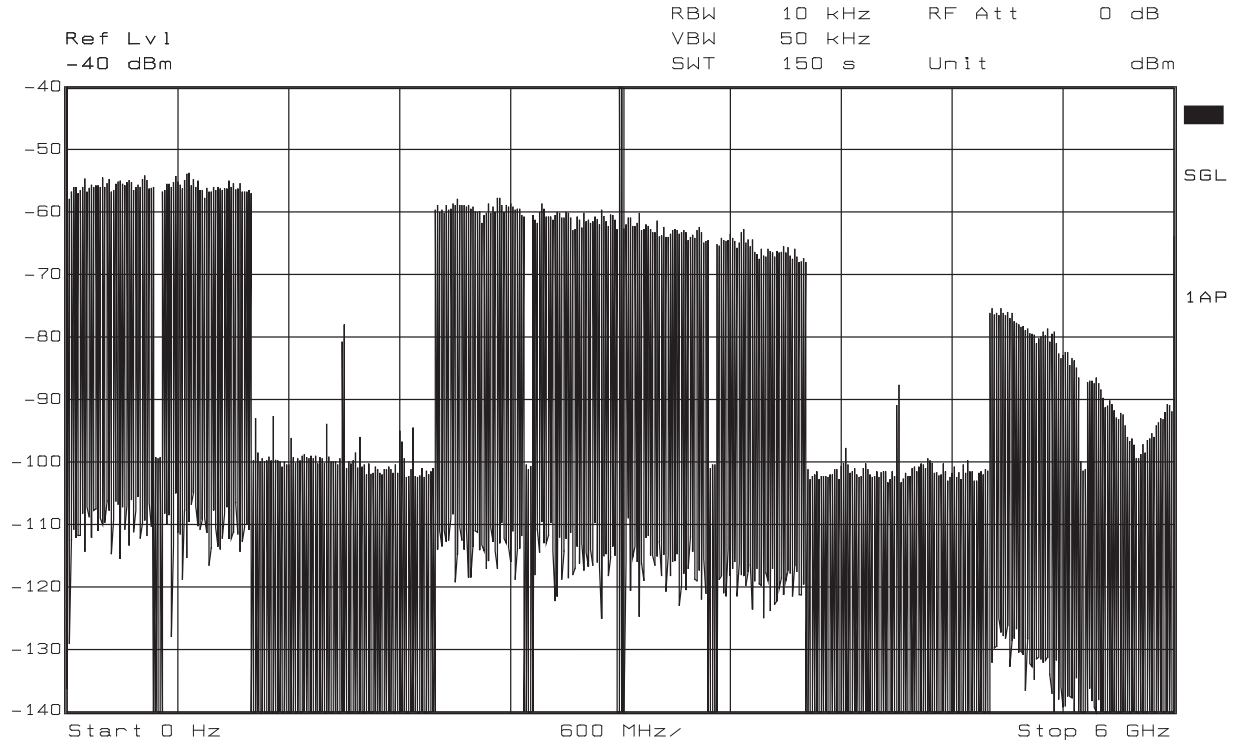
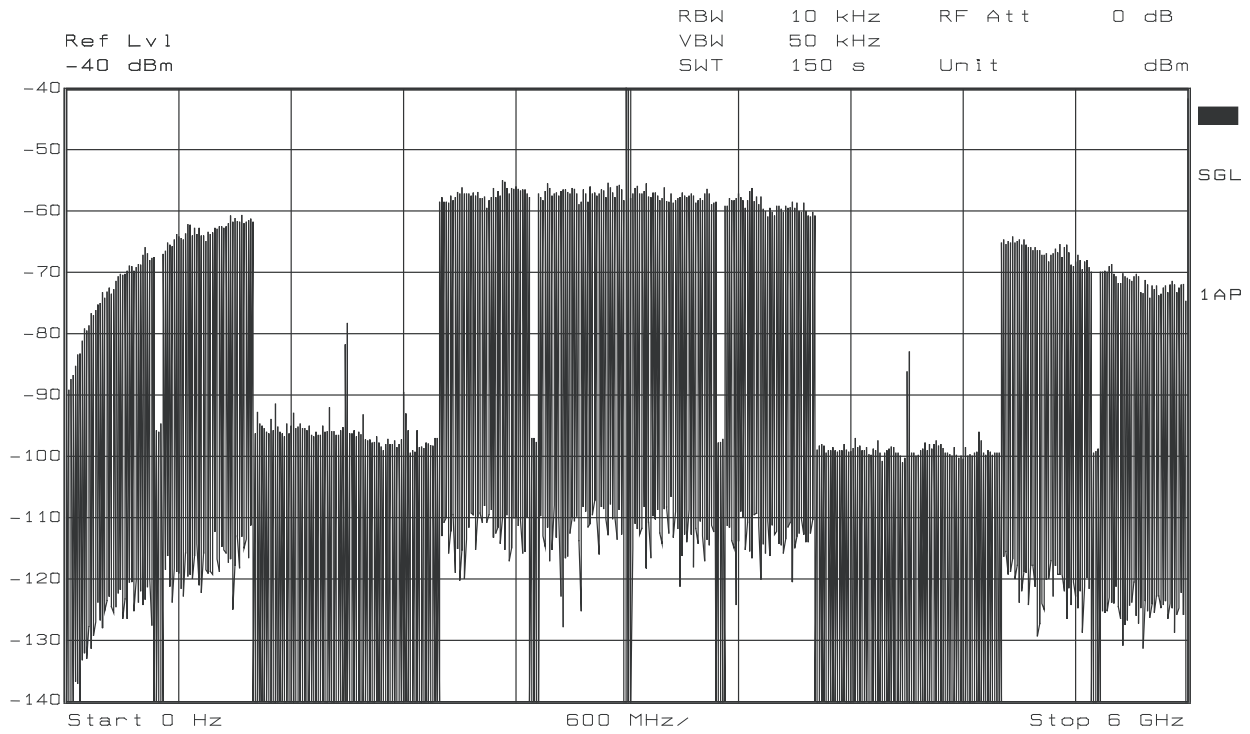

Figure 7-53. Spectrum over 4 Nyquist Zones at 3 Gps in RTZ Output Mode



First Zero of the sinc() function is slightly before $2 \cdot F_{clock}$ which indicates that the duty cycle of RTZ function is a little bit more than 50%, this is due to the balun which introduced some phase error beyond the 180 degrees between CLK and CLKN thus creating a duty cycle on the clock actually seen by the DAC.

Figure 7-54. Spectrum over 4 Nyquist Zones at 3 Gps in RF Output Mode



Measurements are showing a pretty good fit with theory, see [Section 5.3 on page 18](#).

8. APPLICATION INFORMATION

For further details, please refer to application note 1087.

8.1 Analog Output (OUT/OUTN)

The analog output should be used in differential way as described in the figures below.

If the application requires a single-ended analog output, then a balun is necessary to generate a single-ended signal from the differential output of the DAC.

Figure 8-1. Analog Output Differential Termination

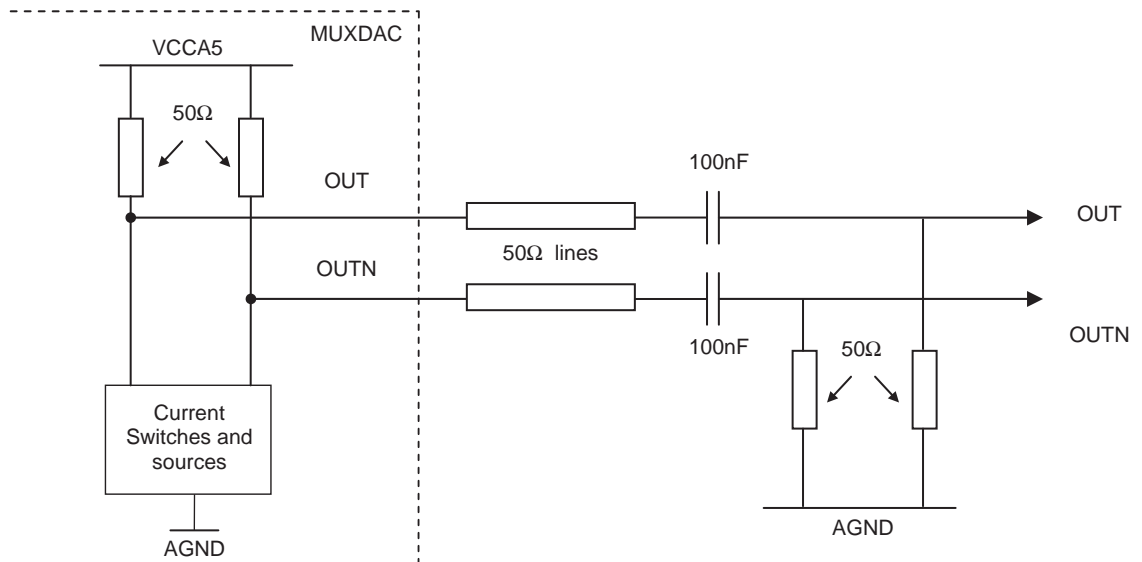
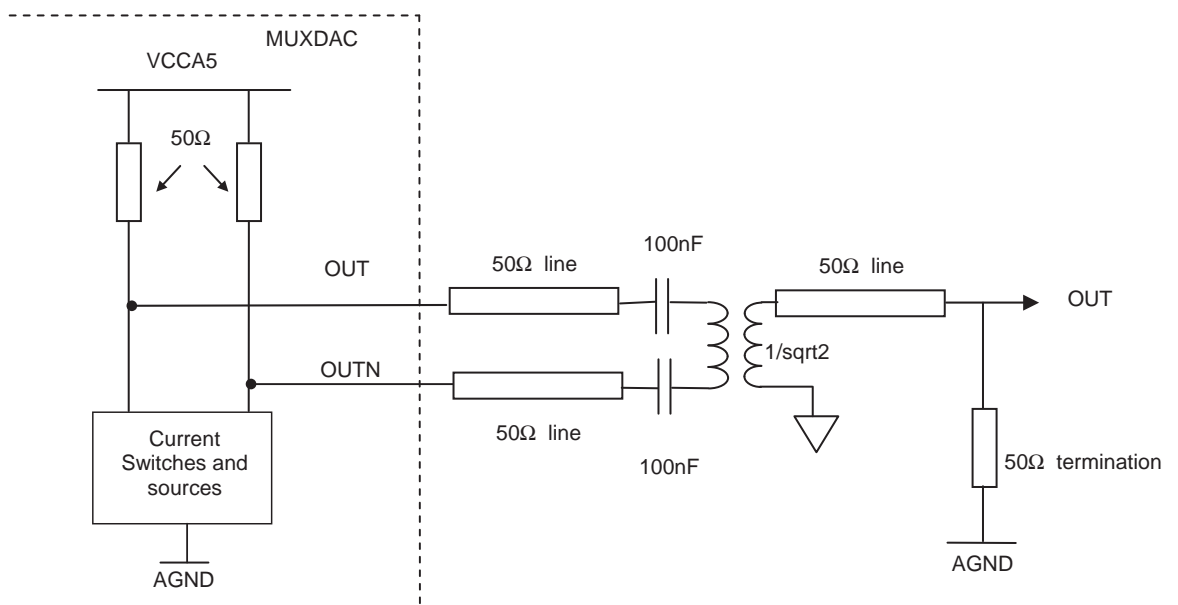

Figure 8-2. Analog Output Using a $1/\sqrt{2}$ Balun



Note: The AC coupling capacitors should be chosen as broadband capacitors with a value depending on the application.

8.2 Clock Input (CLK/CLKN)

The DAC input clock (sampling clock) should be entered in differential mode as described in [Figure 5-11](#).

Figure 8-3. Clock Input Differential Termination

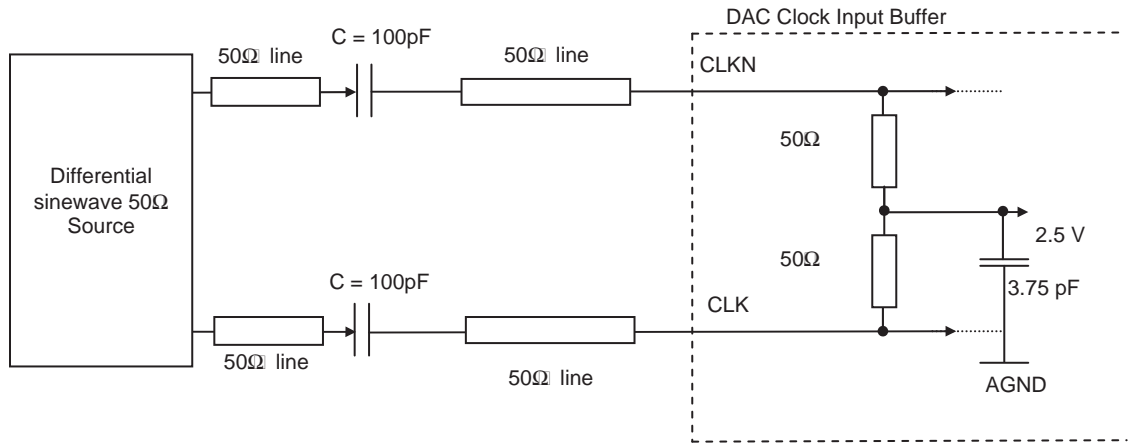

Note: The buffer is internally pre-polarized to 2.5V (buffer between V_{CC5} and AGND).

Figure 8-4. Clock Input Differential with Balun

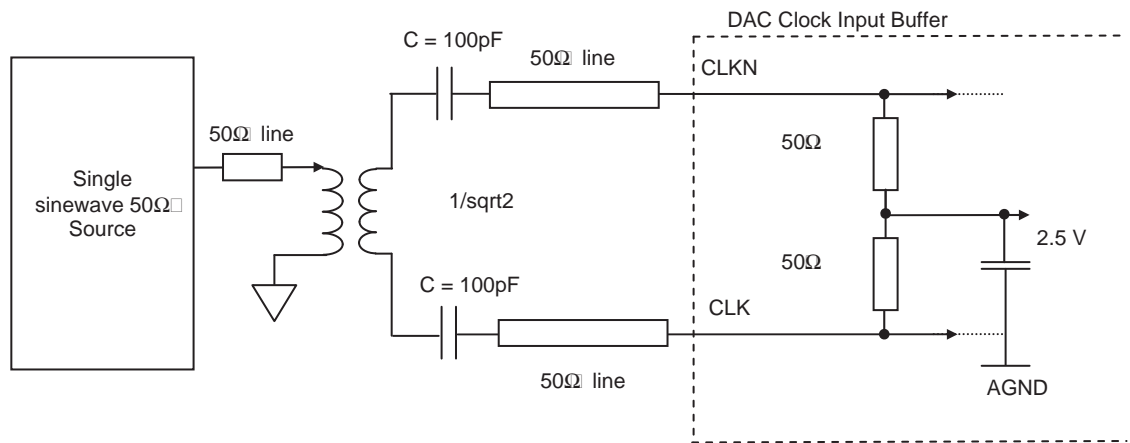

Note: The AC coupling capacitors should be chosen as broadband capacitors with a value depending on the application.

8.3 Digital Data, SYNC and IDC Inputs

LVDS buffers are used for the digital input data, the reset signal (active high) and IDC signal. They are all internally terminated by $2 \times 50\Omega$ to ground via a 3.75 pF capacitor.

Figure 8-5. Digital Data, Reset and IDC Input Differential Termination

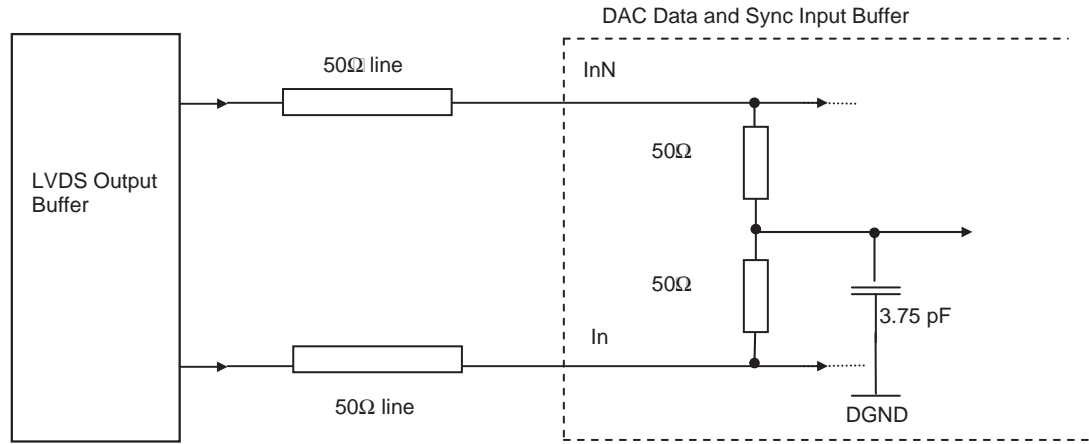

- Notes:
1. In the case when only two ports are used (2:1 MUX ratio), then the unused data should be left open (no connect).
 2. Data and IDC signals should be routed on board with the same layout rules and the same length than the data.
 3. In case SYNC is not used, it is necessary to bias the SYNC to 1.1V and SYNCN to 1.4V on EV12DS130A.

8.4 DSP Clock

The DSP, DSPN output clock signals are LVDS compatible.

They have to be terminated via a differential 100Ω termination as described in [Figure 5-13](#).

Figure 8-6. DSP Output Differential Termination

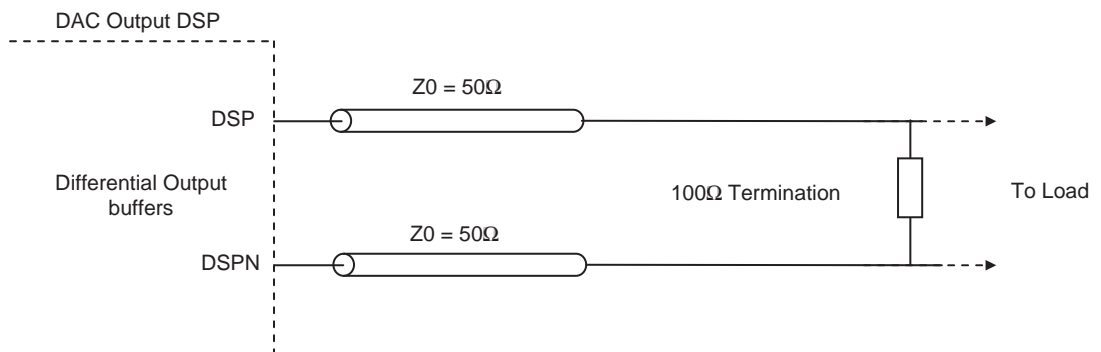

8.5 Control Signal Settings

The MUX, MODE, PSS and OCDS control signals use the same static input buffer.

Logic "1" = 200 K Ω to Ground, or tied to $V_{CCD} = 3.3V$ or left open

Logic "0" = 10 Ω to Ground or Grounded

Figure 8-7. Control Signal Settings

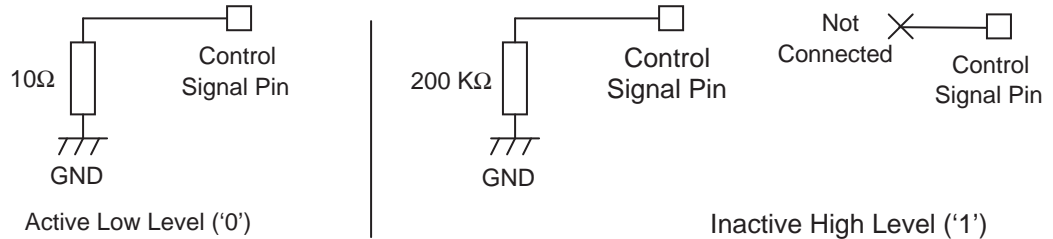

The control signal can be driven by FPGA.

Figure 8-8. Control Signal Settings with FPGA



Logic "1" > V_{IH} or $V_{CCD} = 3.3V$

Logic "0" < V_{IL} or 0V

8.6 HTVF and STVF Control Signal

The HTVF and STVF control signals is a 3.3V CMOS output buffer.

These signals could be acquired by FPGA.

Figure 8-9. Control Signal Settings with FPGA

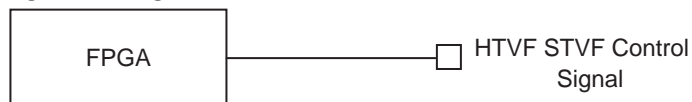

In order to modify the V_{OL}/V_{OH} value, pull up and pull down resistances could be used, or a potential divider.

8.7 GA Function Signal

This function allows adjustment of the internal gain of the DAC.

The gain of the DAC can be tuned with applied analog voltage from 0 to V_{CCA3}

This analog input signal could be generated by a DAC controlled by FPGA or microcontroller.

Figure 8-10. Control Signal Settings with GA



8.8 Power Supplies Decoupling and Bypassing

The DAC requires 3 distinct power supplies:

$V_{CCA5} = 5.0V$ (for the analog core)

$V_{CCA3} = 3.3V$ (for the analog part)

$V_{CCD} = 3.3V$ (for the digital part)

It is recommended to decouple all power supplies to ground as close as possible to the device balls with 100 pF in parallel to 10nF capacitors. The minimum number of decoupling pairs of capacitors can be calculated as the minimum number of groups of neighboring pins.

4 pairs of 100pF in parallel to 10 nF capacitors are required for the decoupling of V_{CCA5} . 4 pairs for the V_{CCA3} is the minimum required and finally, 10 pairs are necessary for V_{CCD} .

Figure 8-11. Power Supplies Decoupling Scheme

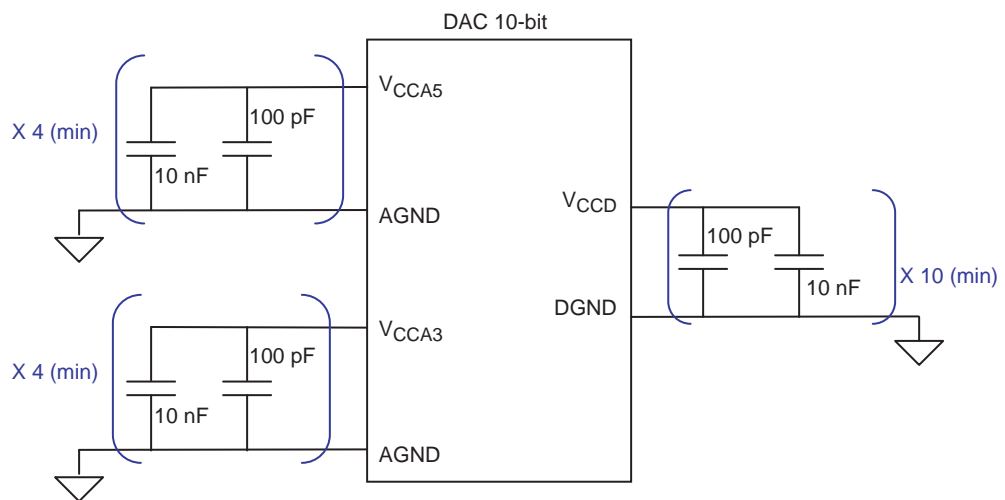

Each power supply has to be bypassed as close as possible to its source or access by 100 nF in parallel to 22 μF capacitors (value depending of DC/DC regulators).

Analog and digital ground plane should be merged.

8.9 Power Up Sequencing

For EV12DS130B there is no forbidden power-up sequence, nor power supplies dependency requirement.

For EV12DS130A the following instructions must be implemented:

Power-up sequence:

It is necessary to raise V_{CCA5} power supply within the range 5.20V up to a recommended maximum of 5.60V during at least 1ms at power up. Then the supply voltage has to settle within 500 ms to a steady nominal supply voltage within a range of 4.75V up to 5.25V.

A power-up sequence on V_{CCA5} that does not comply with the above recommendation will not compromise the functional operation of the device. Only the noise floor will be affected.

Figure 8-12. Power-up Sequence

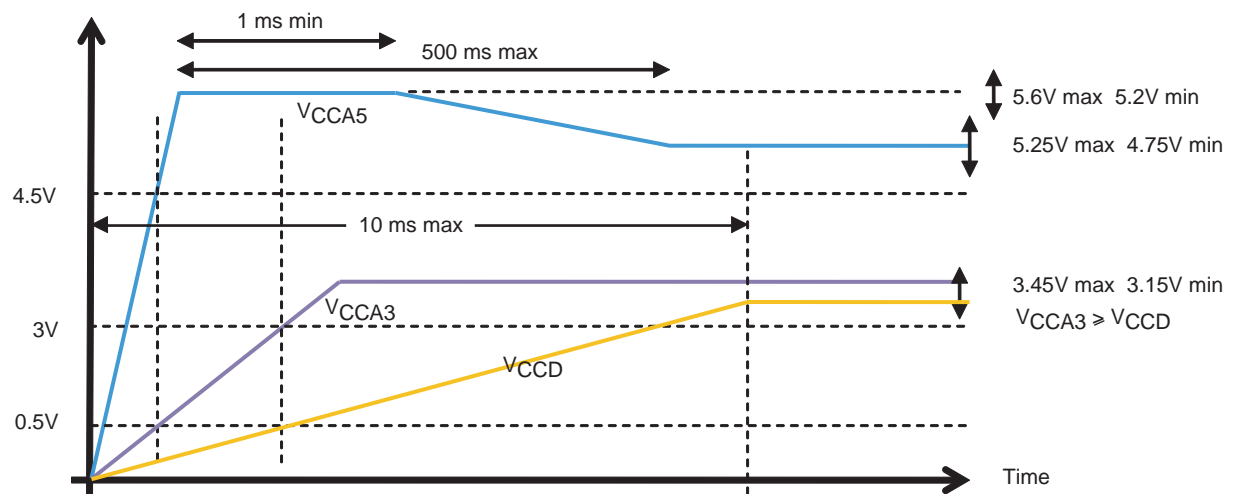

The rise time for any of the power supplies (V_{CCA5} , V_{CCA3} and V_{CCD}) shall be ≤ 10 ms.

At power-up a SYNC pulse is internally and automatically generated when the following sequence is satisfied: V_{CCD} , V_{CCA3} and V_{CCA5} . To cancel the SYNC pulse at power-up, it is necessary to apply the sequence: V_{CCA5} , V_{CCA3} , V_{CCD} . (It is mandatory that V_{CCD} is the last supply to rise and always remains behind V_{CCA5} and V_{CCA3}). Any other sequence may not have a deterministic SYNC behaviour. See erratasheet (ref 1125) for specific condition of use relative to the SYNC operation.

Relationship between power supplies:

Within the applicable power supplies range, the following relationship shall always be satisfied $V_{CCA3} \geq V_{CCD}$, taking into account AGND and DGND planes are merged and power supplies accuracy.

8.10 Balun Influence

It is important to know that balun characteristic may influence significantly DAC output spectral response. Especially harmonic distortion can dramatically be degraded when part of the band of interest lies out of the specified domain of the balun.

As depicted in the following figure an inappropriate balun choice can result in a strong increase in harmonic peaks amplitude, thus degrading performances. The balun used in this measurement covers only the 500MHz to 7GHz band so that the DC to 500MHz region of the first nyquist zone is distorted.

Figure 8-13. Observation of the 1st and 2nd nyquist zones in output mode RTZ with 0.5 GHz-7 GHz Balun

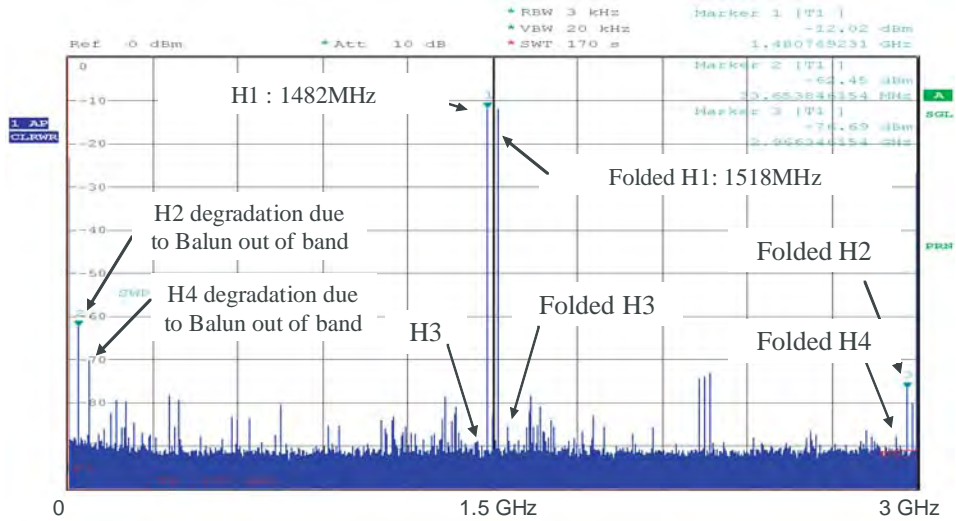

On the opposite, when appropriate balun is used the real device response is measured.

Figure 8-14. Spectrum of the 1st Nyquist Zone, Output Mode RTZ with a 2 MHz to 2GHz Bandwidth Balun

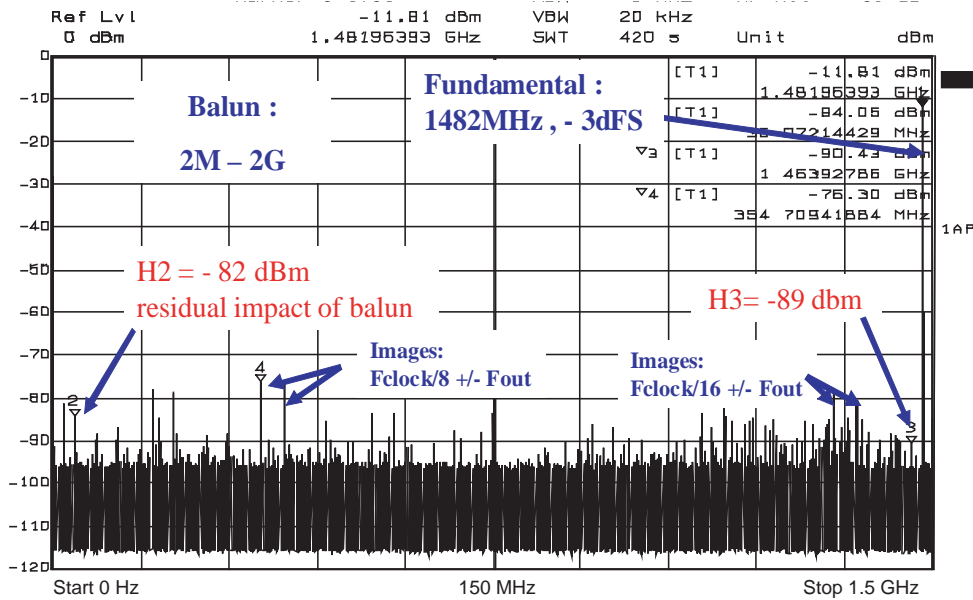

As a consequence, one must be aware that optimum performances can only be reached when using a balun optimal for the band of interest of the application. We specifically recommend selecting a balun which frequency domain covers the whole band of interest (for instance one whole Nyquist zone).

9. PACKAGE DESCRIPTION

9.1 Ci-CGA255 Outline

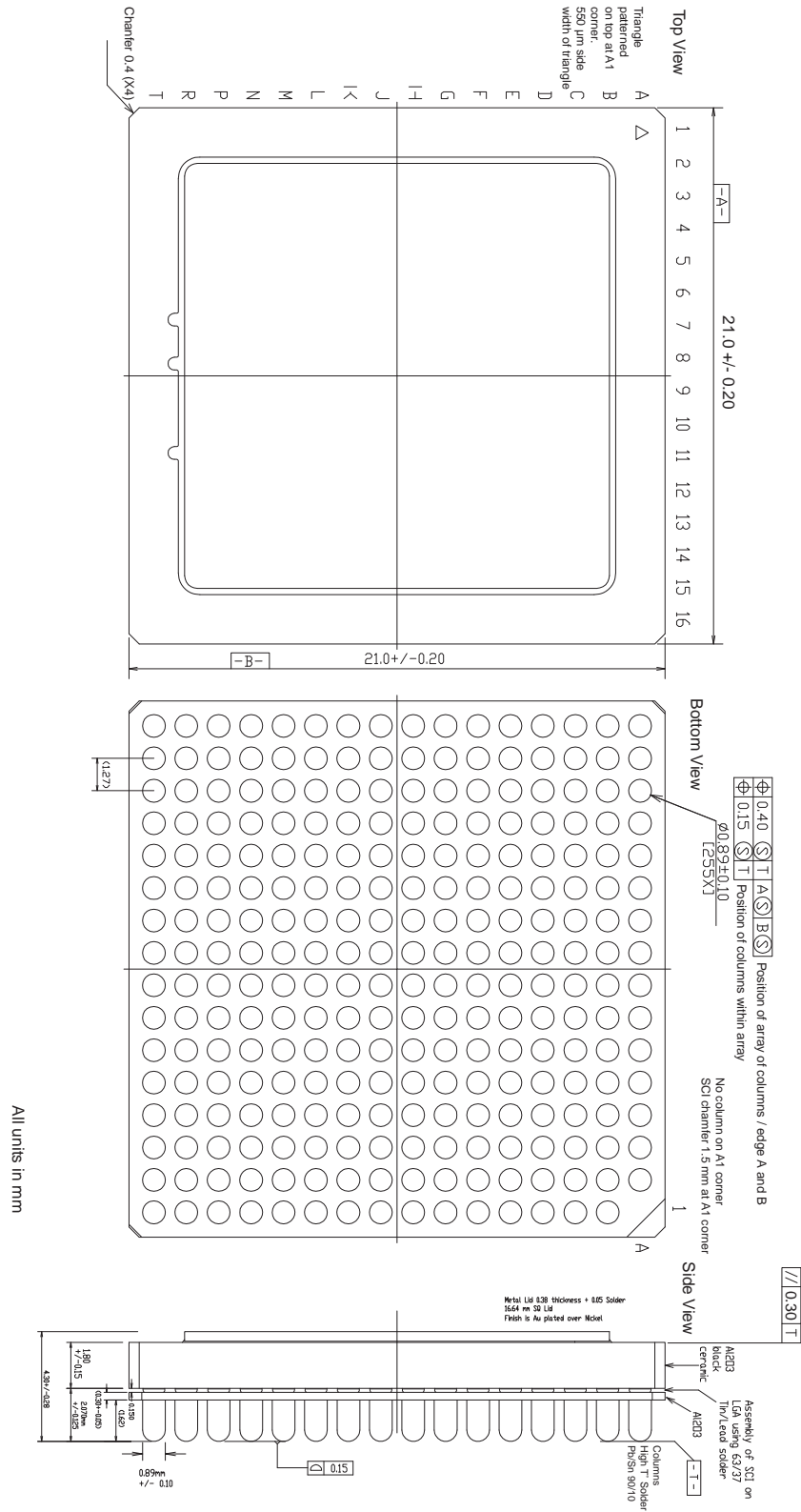

9.2 CLGA255 Outline

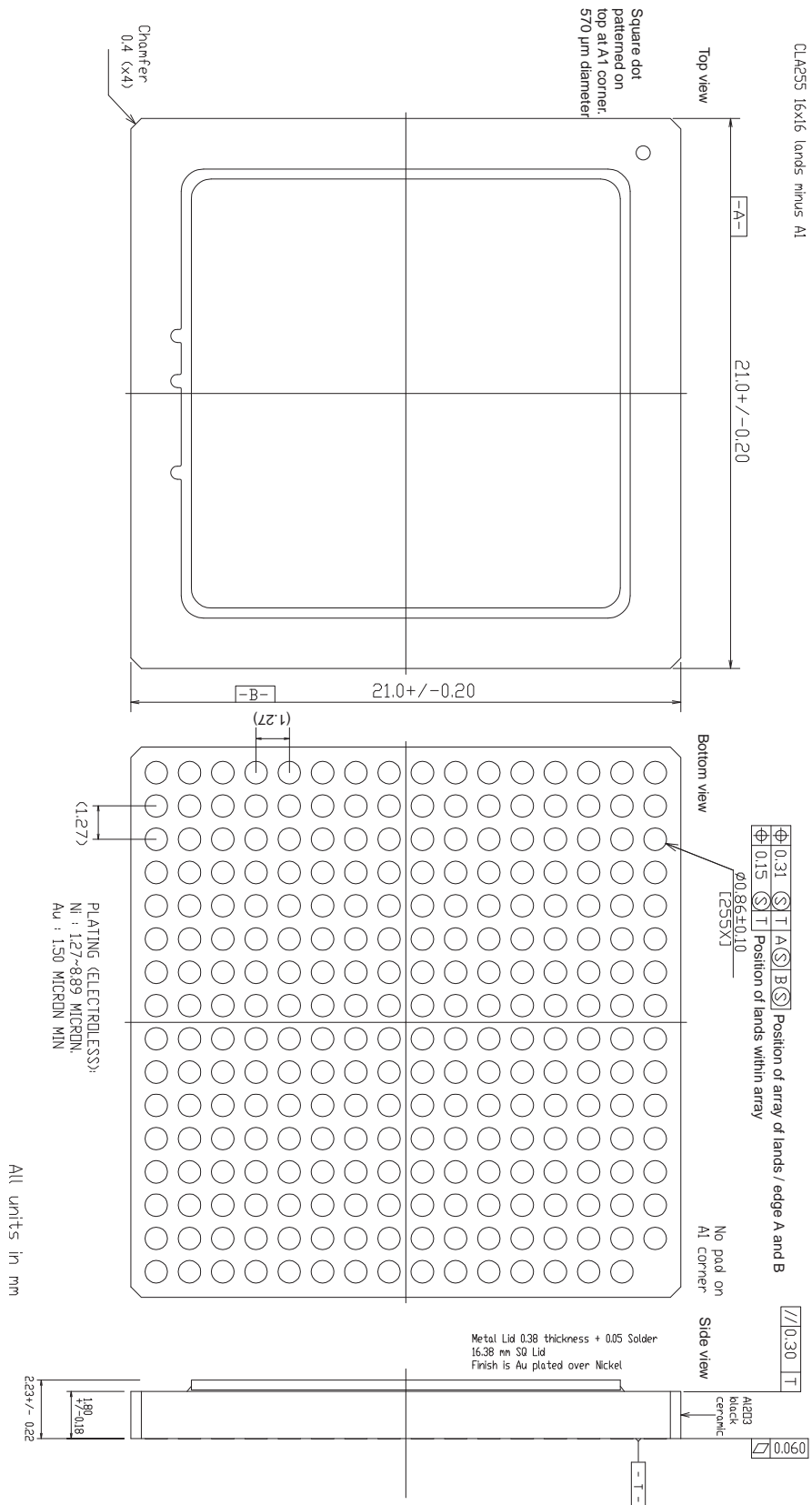

9.3 CCGA255 Outline

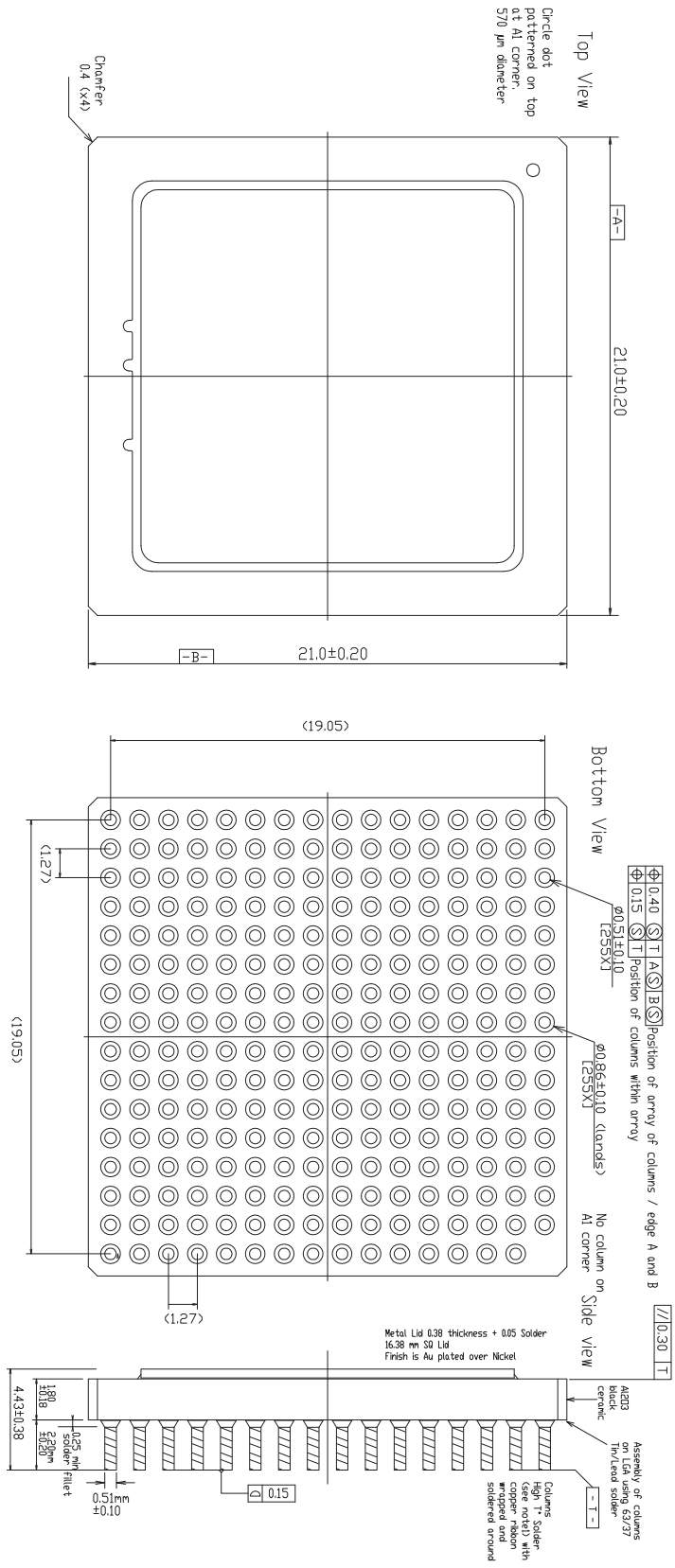

Note 1
 Initial column core composition (prior to column wire manufacturing): Sn20–Pb80 (wt %).
 Final column core composition (after column attach on CLGA packages): 55 ≤ Pb wt% ≤ 80

All units in mm

9.4 Thermal Characteristics

Assumptions:

- Die thickness = 300 μm
- No convection
- Pure conduction
- No radiation

R_{TH}	Heating zone	Ci CGA	CCGA	Unit
Junction-> Bottom of columns	7.5% die area : 4580x4580 μm	13.8	15.0	$^{\circ}\text{C}/\text{W}$
Junction-> Board (JEDEC JESD51-8) Boad size = 39x39mm, 1.6 mm Thickness)		17.1	18.6	$^{\circ}\text{C}/\text{W}$
Junction -> Top of Lid		19.3	22.0	$^{\circ}\text{C}/\text{W}$
$T_{jhot\ spot} - T_{Jdiode}$		3.3	3.3	$^{\circ}\text{C}/\text{W}$

Typical Assumptions:

- Convection according to JEDEC
- Still air
- Horizontal 2s2p board
- Board size 114.3 \times 76.2 mm, 1.6 mm thickness

R_{TH}	Heating zone	Ci CGA	CCGA	Unit
Junction -> Ambient	18% die area : 4820x4820 μm	29.5	29.4	$^{\circ}\text{C}/\text{W}$
$T_{jhot\ spot} - T_{Jdiode}$		3.3	3.3	$^{\circ}\text{C}/\text{W}$

10. DIFFERENCES BETWEEN EV12DS130A AND EV12DS130B

EV12DS130A and EV12DS130B exhibit the same dynamic performances.

EV12DS130B requires no specific dependency between power supplies nor power up sequences while the EV12DS130A does require specific power up sequences as described in [Section 8.9 on page 75](#).

Maximum supported sampling frequency with DSP clock feature for EV12DS130B is 2.1GHz due to internal jitter. It is however possible to benefit from the EV12DS130B DAC performances up to 3GHz if specific system architecture is implemented. Please refer to application AN1141 for further information.

No SYNC timing constraints (other than T1 T2) are required on EV12DS130B.

As a summary

When using EV12DS130A, please ensure your system fulfills those specific recommendations

- Power Up Sequence (See [Section 8.9 on page 75](#))
- Power supplies dependency (see [Section 8.9 on page 75](#))
- SYNC pin have to be driven in any case
- Please refer to errata sheet 1125

When using EV12DS130B, please ensure your system fulfills those specific recommendations

- In case sampling frequency is above 2.1 Gsps, please read the AN1141 “Using EV1xDS130B at sampling rate higher than 2.1GSps”

Please refer to application note AN1140 "Replacing EV1xDS130A with EV1xDS130B" for further details

11. ORDERING INFORMATION

Please refer to datasheet details and application notes before ordering.

Table 11-1. Ordering Information

Part Number	SMD Number	Package	Temperature Range	Screening Level	Comments
EV12DS130AG					
EVX12DS130AGS		CI-CGA255	Ambient	Prototype	
EV12DS130AMGSD/T		CI-CGA255	-55°C < Tc,Tj < 125°C	EQM Grade	
EV12DS130AMGS9NB1		CI-CGA255	-55°C < Tc,Tj < 125°C	Space Grade	
EV12DS130AGS-EB		CI-CGA255	Ambient	Prototype	Evaluation board
EVX12DS130ALG		LGA255	Ambient	Prototype	
EV12DS130AMLGD/T		LGA255	-55°C < Tc,Tj < 125°C	EQM Grade	
EV12DS130AMLG9NB1		LGA255	-55°C < Tc,Tj < 125°C	Space Grade	
EVX12DS130AGC		CCGA255	Ambient	Prototype	
EV12DS130AMGC		CCGA255	-55°C < Tc,Tj < 125°C	Engineering model	
EV12DS130AMGCD/T		CCGA255	-55°C < Tc,Tj < 125°C	EQM Grade	
EV12DS130AMGC9NB1		CCGA255	-55°C < Tc,Tj < 125°C	Space Grade	
EV12DS130AMLG-V	5962-1522201VXC	LGA255	-55°C < Tc,Tj < 125°C	QML-V Grade MIL PRF 38535	
EV12DS130AMGS-V	5962-1522201VYF	CI-CGA255	-55°C < Tc,Tj < 125°C	QML-V Grade MIL PRF 38535	
EV12DS130AMGC-V	5962-1522201VZF	CCGA255	-55°C < Tc,Tj < 125°C	QML-V Grade MIL PRF 38535	

Table 11-1. Ordering Information (Continued)

Part Number	SMD Number	Package	Temperature Range	Screening Level	Comments
EV12DS130BG					
EVX12DS130BGS		CI-CGA255	Ambient	Prototype	
EV12DS130BGS-EB		CI-CGA255	Ambient	Prototype	Evaluation board
EVX12DS130BLG		LGA255	Ambient	Prototype	
EV12DS130BMLG		LGA255	-55°C < Tc,Tj < 125°C	Engineering model	Contact Marketing/pending qualification
EV12DS130BMLGD/T		LGA255	-55°C < Tc,Tj < 125°C	EQM Grade	Contact Marketing/pending qualification
EV12DS130BMLG9NB1		LGA255	-55°C < Tc,Tj < 125°C	Space Grade	Contact Marketing/pending qualification
EVX12DS130BGC		CCGA255	Ambient	Prototype	
EV12DS130BMGC		CCGA255	-55°C < Tc,Tj < 125°C	Engineering model	Contact Marketing/pending qualification
EV12DS130BMGCD/T		CCGA255	-55°C < Tc,Tj < 125°C	EQM Grade	Contact Marketing/pending qualification
EV12DS130BMGC9NB1		CCGA255	-55°C < Tc,Tj < 125°C	Space Grade	Contact Marketing/pending qualification
EV12DS130BMLG-V	5962-1522201VXC	LGA255	-55°C < Tc,Tj < 125°C	QML-V Grade MIL PRF 38535	
EV12DS130BMGS-V	5962-1522201VYF	CI-CGA255	-55°C < Tc,Tj < 125°C	QML-V Grade MIL PRF 38535	
EV12DS130BMGC-V	5962-1522201VZF	CCGA255	-55°C < Tc,Tj < 125°C	QML-V Grade MIL PRF 38535	

12. REVISION HISTORY

This table provides revision history for this document.

Table 12-1. Revision History

Rev. No	Date	Substantive Change(s)
1080I	August 2016	<p>Table 11-1, "Ordering Information," on page 81: Introduction of QML-V grade for EV12DS130B</p> <p>Typo correction</p>
1080H	March 2016	<p>Introduction of QML-V grade and add EV12DS130AMGC</p>
1080G	December 2014	<p>Section 5.6 on page 28: OCDS [10] not allowed</p> <p>Introduction and description of EV12DS130B</p> <p>New Section 10. "Differences between EV12DS130A and EV12DS130B" on page 80</p> <p>Table 3-6, "AC Electrical Characteristics RTZ Mode (Second Nyquist Zone)(2)," on page 10: Limits update</p> <p>Table 3-9, "Coding Table (Theoretical values)," on page 15: typo error on lines (RTZ) and (NRTZ)</p> <p>Section 5.1 "DSP Output Clock" on page 18 updated</p> <p>Section 5.3 "MODE Function" on page 18: equations updated</p> <p>Section 5.5 "PSS (Phase Shift Select Function)" on page 26 updated</p> <p>Section 5.9 "Synchronization functions for multi-DAC operation" on page 31 updated</p> <p>Figure 7-5 on page 42 updated</p> <p>Figure 7-13 on page 46 updated</p> <p>New Section 7.2.3 "Single tone measurements: typical spectra at 3Gsps" on page 50</p> <p>New Section 8.10 "Balun Influence" on page 76</p> <p>Table 11-1, "Ordering Information," on page 81</p>
1080F	May 2014	<p>Table 3-3: Change max current ICCD limit (2:1 & 4:1 MUX mode)</p> <p>Table 3-3: Output internal differential resistor is test level 1 & 6</p> <p>Table 3-6: remove minimum limit on SFDR in 4:1 MUX mode Fs = 3Gsps @ Fout = 1600MHz 0 dBFS (now test level 4)</p> <p>Table 3-6: remove maximum limit on highest spur level in 4:1 MUX mode Fs = 3Gsps @ Fout = 1600MHz 0 dBFS (now test level 4)</p> <p>Table 3-8: provide min & max limits for Input data rate in 2:1 and 4:1 MUX mode.</p> <p>Table 3-8: Delay TDP is renamed TPD. It is a typ value and not a max value</p> <p>Section 4. "Definition of Terms" on page 16:</p> <ul style="list-style-type: none"> - TOD definition is replace by TPD/TOD definition for clarification - Typo correction on RTZ and NRTZ term <p>Figure 8-11: modification of power supplies decoupling scheme on VCCA3 and VCCD</p> <p>Typo errors</p>
1080E	December 2013	<p>Typo errors correction in formula of Section 5.3 "MODE Function" on page 18 and Section 5.6 "Output Clock Division Select Function" on page 28</p> <p>Section 9.3 "CCGA255 Outline" on page 79 CCGA Outline drawing</p> <p>Table 3-2, "Recommended Conditions of Use," on page 4: typo errors on note 2: $V_{CCA3} \geq V_{CCD}$</p> <p>Table 3-3, "Electrical Characteristics," on page 5: typo errors on note 7: $V_{CCA3} \geq V_{CCD}$</p>

Table 12-1. Revision History (Continued)

Rev. No	Date	Substantive Change(s)
1080D	July 2013	Typo errors OCDS restrictions HTVF STVF flag application clarification Power sequencing modification. Sync operation clarification. Add LGA and CCGA outline drawing
1080C	July 2012	Typo errors absolute max rating clarifications addition of pin equivalent schematic description Power sequencing recommendation
1080B	February 2012	Typo errors Rth adjustment.
1080A	February 2012	Initial Revision

Table of Contents

	MAIN FEATURES	1
	PERFORMANCES	1
	APPLICATIONS	1
1	Block Diagram	2
2	Description	2
3	Electrical Characteristics	3
	3.1 Absolute Maximum Ratings	3
	3.2 Recommended Conditions of Use	4
	3.3 Electrical Characteristics	5
	3.4 AC Electrical Characteristics	7
	3.5 Timing Characteristics and Switching Performances	12
	3.6 Explanation of Test Levels	14
	3.7 Digital Input Coding Table	15
4	Definition of Terms	16
5	Functional Description	17
	5.1 DSP Output Clock	18
	5.2 Multiplexer	18
	5.3 MODE Function	18
	5.4 Input Under Clocking Mode (IUCM), Principle and Spectral Response	23
	5.5 PSS (Phase Shift Select Function)	26
	5.6 Output Clock Division Select Function	28
	5.7 Synchronization FPGA-DAC: IDC_P, IDC_N, HTVF and STVF Functions	29
	5.8 OCDS, MUX Combinations Summary	31
	5.9 Synchronization functions for multi-DAC operation	31
	5.10 Gain Adjust GA Function	32
	5.11 Diode Function	33
6	PIN Description	34
7	Characterization Results	39
	7.1 Static Performances	39
	7.2 AC Performances	42

8	<i>Application Information</i>	70
8.1	Analog Output (OUT/OUTN)	70
8.2	Clock Input (CLK/CLKN)	71
8.3	Digital Data, SYNC and IDC Inputs	72
8.4	DSP Clock	72
8.5	Control Signal Settings	73
8.6	HTVF and STVF Control Signal	73
8.7	GA Function Signal	73
8.8	Power Supplies Decoupling and Bypassing	74
8.9	Power Up Sequencing	75
8.10	Balun Influence	76
9	<i>Package Description</i>	77
9.1	Ci-CGA255 Outline	77
9.2	CLGA255 Outline	78
9.3	CCGA255 Outline	79
9.4	Thermal Characteristics	80
10	<i>Differences between EV12DS130A and EV12DS130B</i>	80
11	<i>Ordering Information</i>	81
12	<i>Revision History</i>	83