

## Datasheet

### Features

- 1.3 million (1280 x 1024) pixels, 5.3  $\mu\text{m}$  square pixels with micro-lens
- Optical format 1/1.8"
- 60 fps@ full resolution
- Embedded functions:
  - Image Histograms and Context output
  - Sub-sampling / binning
  - Multi-ROI (including 1 line mode)
  - Defective pixel correction
  - PLL with 5 to 50 MHz input frequency range (compatible with dithered master clock)
  - High dynamic range capabilities
  - Time to Read improvement (Abort image and Good first image)
- Timing modes:
  - Global shutter in serial and overlap modes
  - Rolling shutter allowing true CDS readout and global reset
- Output format 8 or 10 bits parallel plus synchronization
- SPI controls
- Control input pins: Trigger, Reset
- Light control output
- 3.3 V and 1.8 V power supplies

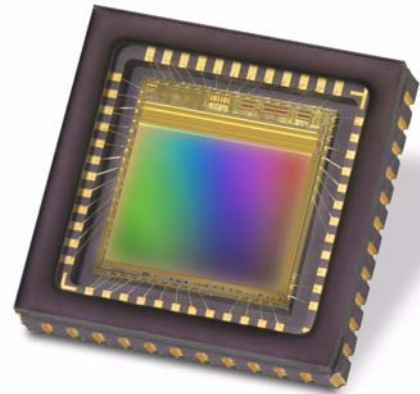

### Performance Characteristics

- Low power consumption (200 mW)
- High sensitivity at low light level
- Operating temperature [-30° to +65°C]
- Peak QE > 60%

### Available Sensor Types

- B&W
- Color (Bayer arrangement)

### Applications

- Surveillance IP/CCTV cameras
- Industrial Machine Vision (Barcode reading)
- Biometrics/Medical Imaging
- Automotive Vision

### Introduction

The EV76C560 is a 1.3 million pixel CMOS image sensor designed with e2v's proprietary Eye-On-Si CMOS imaging technology. It is suitable for many different types of application where superior performance is required. The innovative pixel design offers excellent performance in low-light conditions with an electronic global (true snapshot) shutter, and offers a high readout speed at 60 fps in full resolution. Its very low power consumption makes it well suited for battery powered applications.

# 1. Typical Performance Data

**Table 1-1.** Typical electro-optical performance @ 25°C and 65°C, nominal pixel clock

Parameter		Unit	Typical value	
<b>Sensor characteristics</b>	Resolution	pixels	1280 (H) × 1024 (V)	
	Image size	mm inches	6.9 (H) × 5.5 (V) - 8.7 (diagonal) ≈ 1/1.8	
	Pixel size (square)	µm	5.3 × 5.3	
	Aspect ratio		5 / 4	
	Max frame rate	fps	60 @ full format	
	Pixel rate	Mpixels / s	90 -> 120	
	Bit depth	bits	10	
<b>Pixel performance</b>			<b>@ T<sub>A</sub> 25°C</b>	<b>@ T<sub>A</sub> 65°C</b>
	Dynamic range <sup>(1)</sup>	dB	>62	>57
	Qsat	ke-	12	
	SNR Max	dB	41	39
	MTF at Nyquist, λ=550 nm	%	50	
	Dark signal <sup>(2)</sup>	LSB <sub>10</sub> /s	24	420
	DSNU <sup>(2)</sup>	LSB <sub>10</sub> /s	6	116
	PRNU <sup>(3)</sup> (RMS)	%	<1	
	Responsivity <sup>(2)</sup> <sup>(4)</sup>	LSB <sub>10</sub> /(Lux.s)	6600	
<b>Electrical interface</b>	Power supplies	V	3.3 & 1.8	
	Power consumption: Functional <sup>(5)</sup> Standby	mW µW	< 200 mW 180	

1. In electronic rolling shutter (ERS) mode.
2. Min gain, 10 bits.
3. Measured @ Vsat/2, min gain.
4. 3200K, window without AR coating, IR cutoff filter BG38 2 mm.
5. @ 60 fps, full format, with 10 pF on each output.

**Figure 1-1.** Spectral response and quantum efficiency

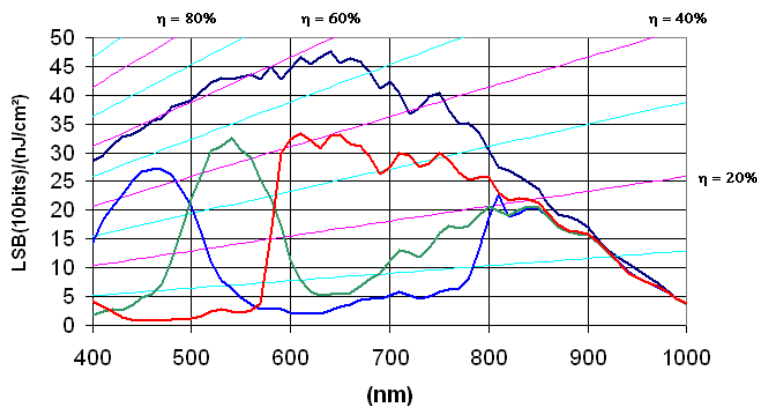

## 2. Sensor Overview

Figure 2-1. Block diagram

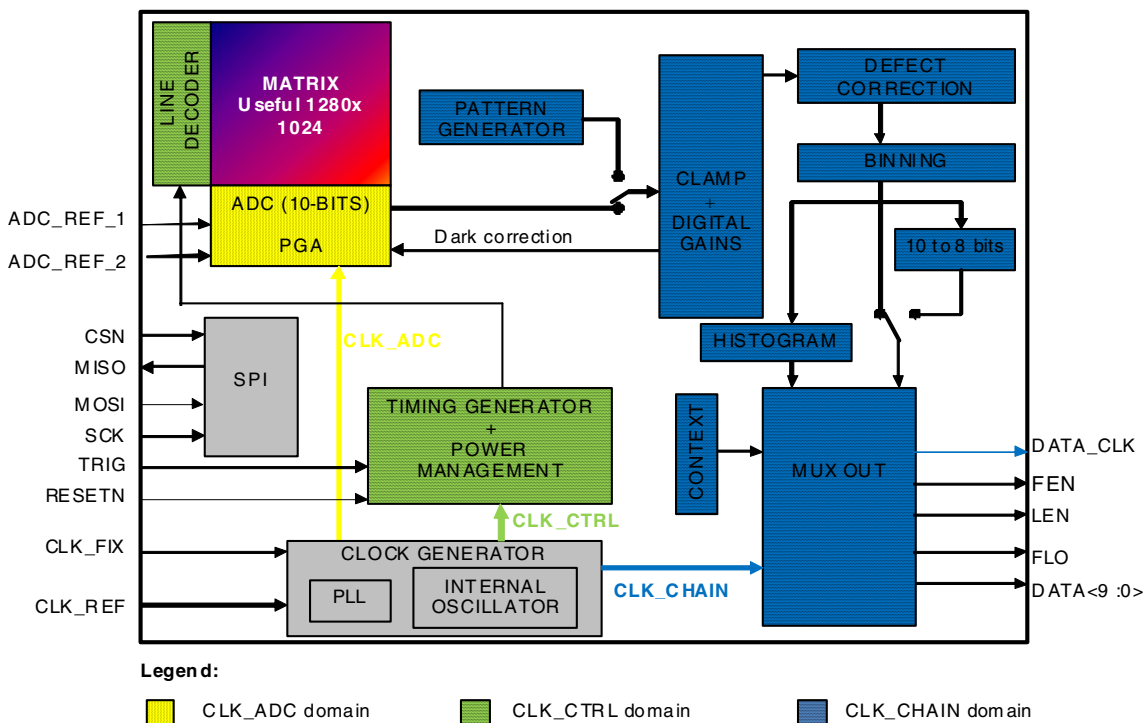

Detailed descriptions of the I/O signals and blocks are given in the datasheet sections listed in [Table 2-1](#). See [Section 21](#), for the device pinout information.

Table 2-1. Quick reference table for block diagram

Signal name	I/O	Description	Reference
ADC_REF1&2	I	ADC reference voltages	<a href="#">Section 5.2</a>
CSN	I	SPI chip select	<a href="#">Section 17.</a>
MISO	O	SPI data output	
MOSI	I	SPI data input	
SCK	I	SPI clock	
TRIG	I	Trigger input	<a href="#">Section 18.</a>
CLK_REF	I	Reference clock input	<a href="#">Section 14.</a>
CLK_FIX	I	Fixed clock input	
RESETN	I	Sensor reset	<a href="#">Section 18.</a>
DATA<9:0>	O	10-bit data output bus	<a href="#">Section 19.</a>
FEN	O	Vertical sync output	
LEN	O	Horizontal sync output	
FLO	O	Illumination control output	
DATA_CLK	O	Output clock	<a href="#">Section 19.6</a>

List of blocks	Reference
Matrix	<a href="#">Section 4.</a>
ADC + PGA	<a href="#">Section 5.</a>
Clamp + digital gain	<a href="#">Section 6. &amp; 7.</a>
Defect correction	<a href="#">Section 8.</a>
Binning	<a href="#">Section 9.</a>
Histogram	<a href="#">Section 10.</a>
10->8 bits	<a href="#">Section 11.</a>
Context	<a href="#">Section 12.</a>
Mux out	<a href="#">Section 13.</a>
Timing and power management	<a href="#">Section 14.</a>
Clock generator	<a href="#">Section 15.</a>
Pattern generator	<a href="#">Section 16.</a>
SPI	<a href="#">Section 17.</a>

## 3. Standard Configuration

### 3.1 Sensor Settings

The static configuration required to allow image capture is as follows:

- All ground pins connected.
- All power supply pins with the same name connected together.
- SPI pins connected to the host controller.
- 1.8 V pins and 3.3 V pins powered-on.
- Input clock driving the CLK\_REF input pin.
- RESETN pin held at high level after the power-on sequence. See [Section 18.1.1](#)
- STANDBY state is deactivated by writing 0 in the *stdby\_rqst* bit in the `<reg_ctrl_cfg>` register. See [Section 17.3.8](#)
- Image capture is triggered by a high level on the TRIG pin or setting the *trig\_rqst* bit in the `<reg_ctrl_cfg>` register. See [Section 17.3.8](#)

For improved performance, VDD33A and VDD18A must be noise-free. The best way to decouple VDD33A and to increase the power supply rejection ratio is to use a linear regulator dedicated to the image sensor. To prevent noise on VDD18A an inductor can be used.

### 3.2 Application Information

Figure 3-1. Required external components

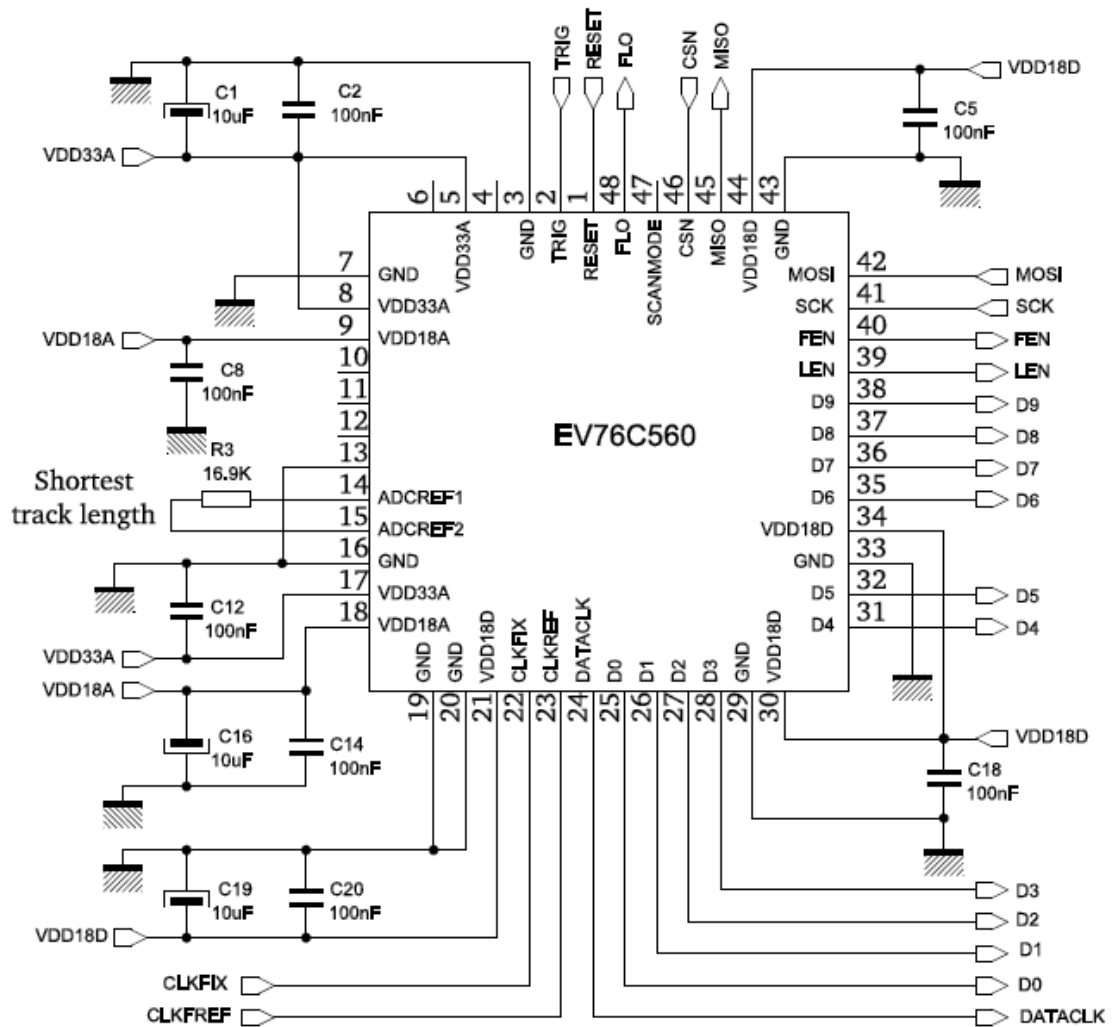

It is recommended to use X7R for all the 100 nF capacitors.

Reset pin has an internal pull-up.

### 3.3 Electrical Levels

**Table 3-1.** DC Characteristics @ 25°C

Parameter	Symbol	Value			Unit
		Min	Typ	Max	
Analog power supply relative to GND	VDD33A	3.15	3.3	3.45	V
Digital power supply relative to GND	VDD18D	1.6	1.8	2	V
Analog power supply relative to GND	VDD18A	1.6	1.8	2	V
Power supply consumption <sup>(1)</sup>	P		190		mW
Supply current at 60 fps (VDD33A pin)	I <sub>VDD33A</sub>		20		mA
Supply current at 60 fps (VDD18A pin)	I <sub>VDD18A</sub>		25		mA
Supply current at 60 fps (VDD18D pin)	I <sub>VDD18D</sub>		30		mA
Standby supply current on VDD33A pin	I <sub>VDD33A(STBY)</sub>		0		
Standby supply current on VDD18A pin	I <sub>VDD18A(STBY)</sub>		0		
Standby supply current on VDD18D pin <sup>(2)</sup>	I <sub>VDD18D(STBY)</sub>		50	100	μA
IDLE supply current on VDD33A pin	I <sub>VDD33A(IDLE)</sub>		6		mA
IDLE supply current on VDD18A pin	I <sub>VDD18A(IDLE)</sub>		0		mA
IDLE supply current on VDD18D pin	I <sub>VDD18D(IDLE)</sub>		7		mA
<b>CMOS in/out</b>					
Input voltage low level	V <sub>IL</sub>			0.3 V <sub>DD18</sub>	V
Input voltage high level	V <sub>IH</sub>	0.7 V <sub>DD18</sub>			V
Input pin capacitance <sup>(3)</sup>	C <sub>IN</sub>		4		pF
Output voltage low level	V <sub>OL1</sub>			0.55	V
Output voltage high level	V <sub>OH1</sub>	V <sub>DD18</sub> -0.55			V
Output current @ V <sub>OH</sub> <sup>(4)</sup>	I <sub>OH</sub>	-10			mA
Output current @ V <sub>OL</sub> <sup>(4)</sup>	I <sub>OL</sub>			10	mA
Input leakage current <sup>(5)</sup>	I <sub>L</sub>	-1		1	μA
ADC_REF current <sup>(6)</sup>	I <sub>ADC_REF</sub>		100		μA

1. Digital output loads =10 pF
2. I<sub>VDD18D(STBY)</sub> with SPI on, without communication and without CLK\_REF input.
3. CLCC48 package
4. On all output pins
5. On all digital input pins
6. On ADC\_REF pins

## 4. Matrix

### 4.1 Useful Area Definition

The useful area is 1280 × 1024 pixels as shown in Figure 4-1.

19 optically shielded reference lines to allow the black level adjustment.

6 dummy illuminated pixels surround the useful area.

Figure 4-1. Area description

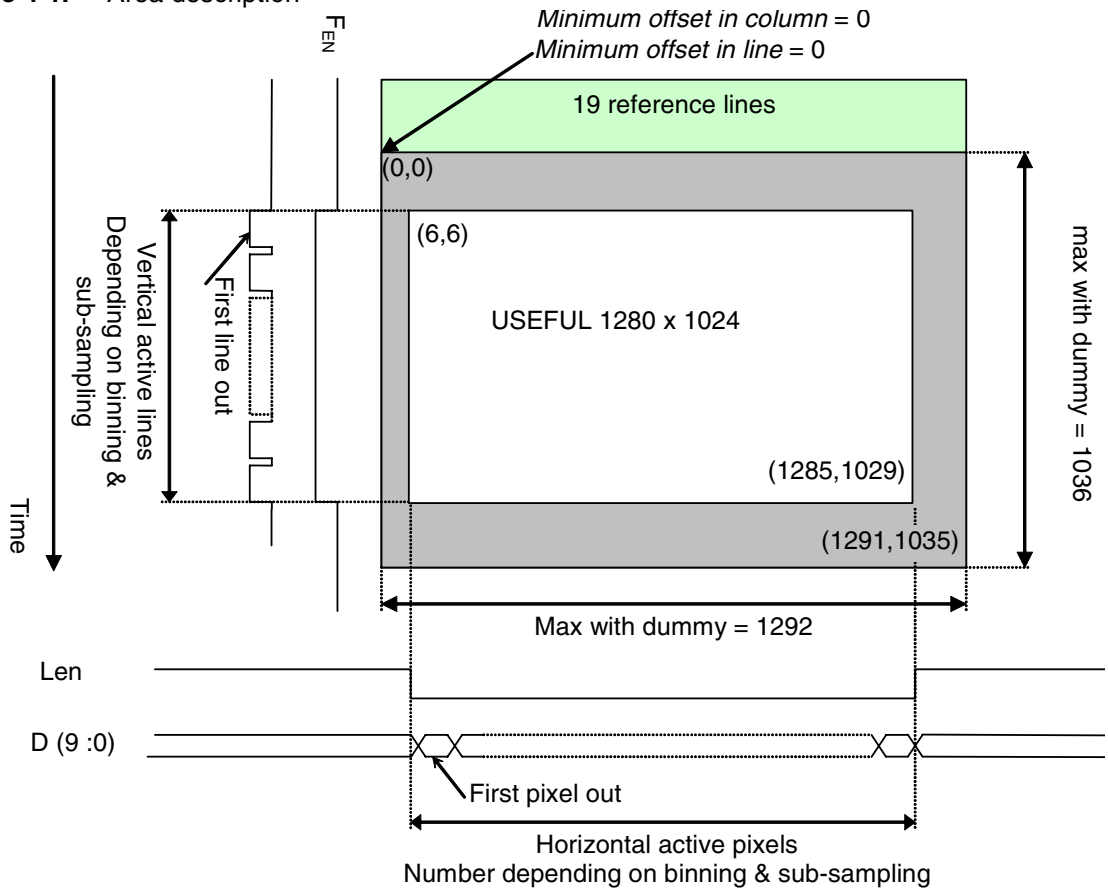

## 4.2 CFA (Color Filter Array)

The following CFA types are implemented:

- Monochrome
- RGB Bayer filter

Other types are available on request.

As CFA choice does not implied a silicon hardware change but only post-process, to allow good choice of binning, subsampling models and color gains use the sensor must be configured by setting 1 in color\_en when a color sensor is used. Note that image size depends on this factor. See [Section 4.5.3.1](#).

**Table 4-1.** Color of first pixel using the flip functions (depends on H&V offset parities)

		RoiX_0l_1 / RoiX_0c_1			
Flip H	Flip V	Odd/Odd	Odd/Even	Even/odd	Even/Even
N	N	Red	Green Red	Green Blue	Blue
N	O	Green Blue	Blue	Red	Green Red
O	N	Green Red	Red	Blue	Green Blue
O	O	Blue	Green Blue	Green Red	Red

RoiX\_0l stands for Roi1\_0l\_1, Roi2\_0l\_1, Roi3\_0l\_1 & Roi4\_0l\_1. See [Section 17.3.11](#), [17.3.12](#), [17.3.13](#), and [17.3.14](#) respect

RoiX\_0c stands for Roi1\_0c\_1, Roi2\_0c\_1, Roi3\_0c\_1 & Roi4\_0c\_1. [Section 17.3.11](#), [17.3.12](#), [17.3.13](#), and [17.3.14](#) respectively

It is recommended to keep:

- Roi\_W\_1 + Roi\_0c\_2 even
- Roi\_h\_1 + Roi\_0l\_2 even

Flip H & Flip V are under roi\_flip\_h & roi\_flip\_v control. See <reg\_miscel2> in [Section 17.3.4](#)

## 4.3 Pixels

The matrix is composed of five transistor (5T) pixels. This structure supports either global shutter (GS) mode or electronic rolling shutter (ERS) mode ([Section 18.2](#)).

## 4.4 Lens CRA (Chief Ray Angle) compensation.

In order to better focus the light rays on the photodiode, the EV76C560 micro lenses are radially shifted to match the exit angles due to the external application lens. This results in improved efficiency and reduced corner shading.

This shift is linearly applied from center (0 shift) to corner ( $\alpha$  angle).



$\alpha$  is the corner CRA (Chief Ray Angle) defined as a mean value of the telecentricity of optics lenses that would be used with the sensor.

The sensor, optimized for a corner CRA of  $12^\circ$ , can be used with a range of telecentricity from  $5^\circ$  to  $20^\circ$  (estimated for fnumber f#/1.2).

Figure 4-2. Microlens Shifting

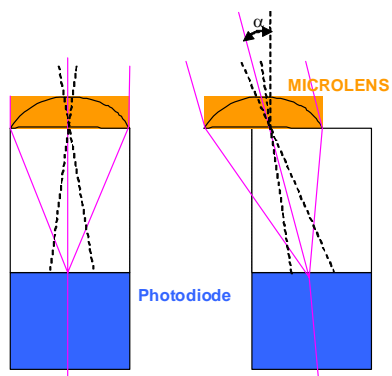
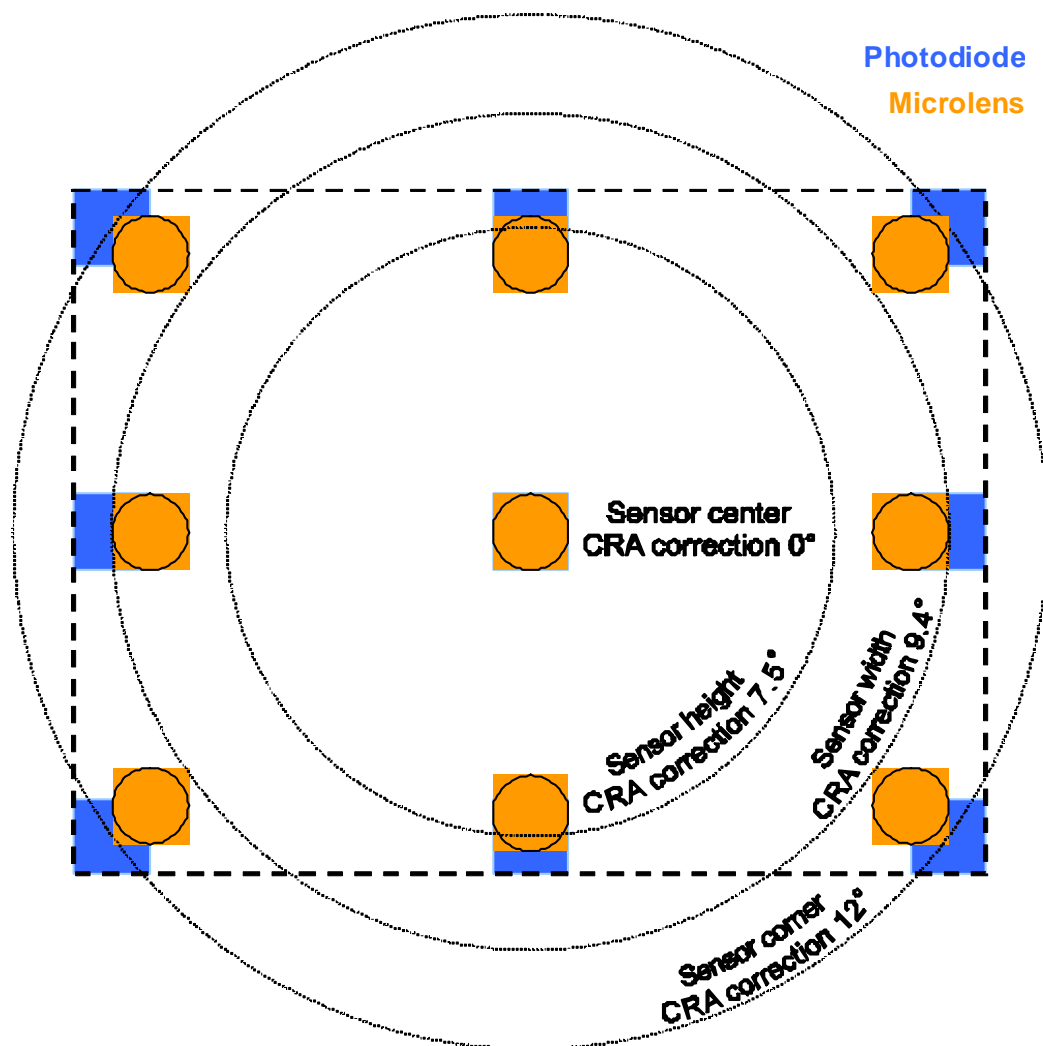

Figure 4-3. Lens CRA overview



## 4.5 Region Of Interest (ROI)

### 4.5.1 Flip Functions

Flip functions are available to allow the application to use any type of lens (with or without mirror). The flip functions are controlled by programming the *roi\_flip\_h* and *roi\_flip\_v* bitfields in the *<reg\_miscel2>* register. See Section 17.3.4. The ROI is applied on the flipped image.

The shielded lines for dark reference are always read first (except in expanded ROI mode selected by the *roi\_expanded* bit in the *<reg\_miscel2>* register (see Section 17.3.4) when whole lines may be read.

Figure 4-4. Flip effects

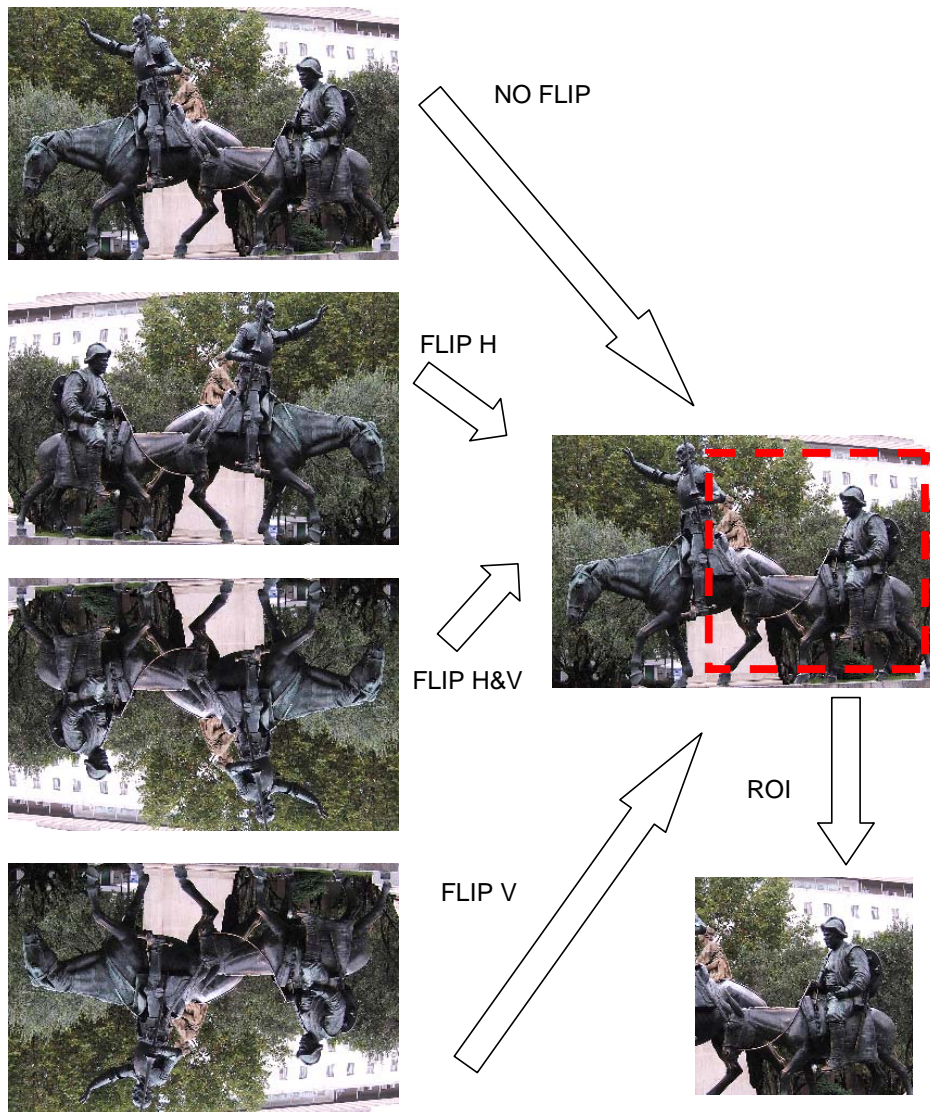

### 4.5.2 ROI Definition

All ROIs are defined in relation to the matrix and useful pixel area (as shown in Figure 4-1). The ROIs are defined before sub-sampling, defect correction and binning.

If a flip effect is used, ROI selection is done after the flip.

### 4.5.3 Sub-Sampling and Windowing

- The sub-sampling function causes the sensor to read only 8 pixels over the selected factor. For example, a sub-sampling factor of 8 over 16 means that the sub-sampling ratio is 1:2. For color sensors, the algorithm is more complicated due to the Bayer organization. Sub-sampling is programmable with a ratio 1 to 32 in steps of 0.125. Different sub-sampling factors can be defined for horizontal and vertical directions. They are programmable using SPI commands: *roiX\_subs\_v* and *roiX\_subs\_h* in *<reg\_roiX\*>* (where X\* is the number of the ROI 1, 2, 3 or 4 registers group) see Section 17.3.11, 17.3.12, 17.3.13, and 17.3.14 respectively.
- Windowing defines the size and position of the ROI. Windowing is defined in two dimensions: horizontal and vertical. The minimum width of the window is 16 columns and the minimum height is 1 line. The user has to define the height, width and offsets of the ROI through the SPI control bus for each ROI used. (See Section 4.5.4).

Windowing, sub-sampling and then binning are possible on the same image.

**Figure 4-5.** Combination of windowing, sub-sampling and binning example for a B&W image.

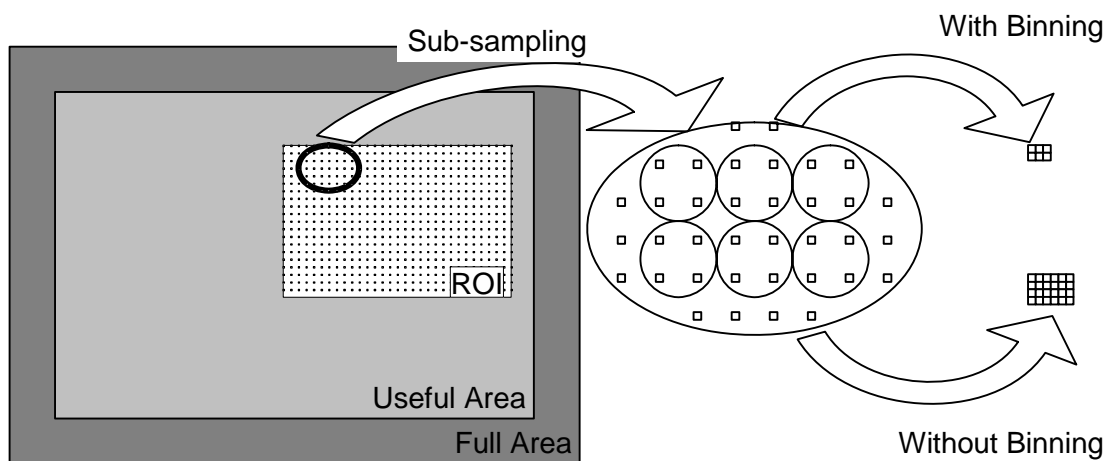

**Figure 4-6.** Sub-sampling example

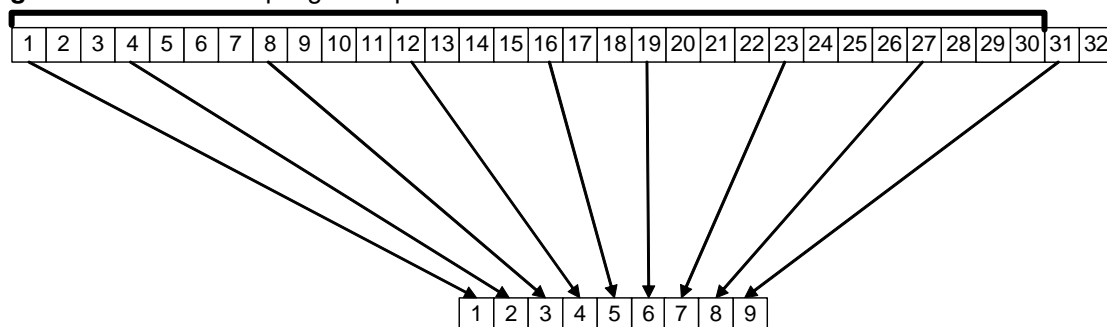

With an 8/30 sub-sampling factor only these pixels (or lines) will be read:

- On the first group of 30 pixels: 1, 4, 8, 12, 16, 19, 23, 27
- On the second group of 30 pixels: 31, 34, 38...
- On the third group of 30 pixels: 61...

Roughly, the sub-sampled image format will be multiplied by  $8/30=1/3.75$ . For more precise calculation of the output image size the following formulas must be used.

#### 4.5.3.1 Calculating the Image Output Size

Image output sizes are determined by the following equations depending on:

- B&W or color version (*color\_en* in `<reg_miscel2>` see Section 17.3.4,
- Sub-sampling factor (*roiN\_subs\_v* and *roiN\_subs\_h* in `<reg_roiN*>` see Section 17.3.11, 17.3.12, 17.3.13, and 17.3.14 respectively),
- Defect correction activation (*roi\_ddc\_en* in `<reg_chain_cfg>` see Section 17.3.7 ),
- Binning activation (*roiN\_binning\_en* in `<reg_chain_cfg>` see Section 17.3.7.

If *roiN\_binning\_en* = 0 AND *color\_en* = 0

For ROI 1:

$$ROI\_width = \text{INT} \left( \frac{8 \times roi1\_w\_1}{roi1\_subs\_factor + 8} \right) + \text{INT} \left( \frac{8 \times roi1\_w\_2}{roi1\_subs\_factor + 8} \right)$$

For ROI 2, 3 and 4:

$$ROI\_width = \text{INT} \left( \frac{8 \times roiN\_w}{roiN\_subs\_factor + 8} \right)$$

If (*roiN\_binning\_en* = 1 AND *color\_en* = 0) OR (*roiN\_binning\_en* = 0 AND *color\_en* = 1)

For ROI 1:

$$ROI\_width = 2 \times \left[ \text{INT} \left( \frac{4 \times roi1\_w\_1}{roi1\_subs\_factor + 8} \right) + \text{INT} \left( \frac{4 \times roi1\_w\_2}{roi1\_subs\_factor + 8} \right) \right]$$

For ROI 2, 3 and 4:

$$ROI\_width = 2 \times \text{INT} \left( \frac{4 \times roiN\_w}{roiN\_subs\_factor + 8} \right)$$

If *roiN\_binning\_en* = 1 AND *color\_en* = 1

For ROI 1:

$$ROI\_width = 4 \times \left[ \text{INT} \left( \frac{2 \times roi1\_w\_1}{roi1\_subs\_factor + 8} \right) + \text{INT} \left( \frac{2 \times roi1\_w\_2}{roi1\_subs\_factor + 8} \right) \right]$$

For ROI 2, 3 and 4:

$$ROI\_width = 4 \times \text{INT} \left( \frac{2 \times roiN\_w}{roiN\_subs\_factor + 8} \right)$$

Then, *width\_out* is:

$$\rightarrow width\_out = \frac{ROI\_width - 4 \times ddc\_en}{2^{roiN\_binning\_en}}$$

If  $roiN\_binning\_en = 0$  AND  $color\_en = 0$

For ROI 1

$$ROI\_height = INT\left(\frac{8 \times roi1\_h\_1}{roi1\_subs\_factor + 8}\right) + INT\left(\frac{8 \times roi1\_h\_2}{roi1\_subs\_factor + 8}\right)$$

For ROI 2, 3 and 4:

$$ROI\_height = INT\left(\frac{8 \times roiN\_h}{roiN\_subs\_factor + 8}\right)$$

If ( $roiN\_binning\_en = 1$  AND  $color\_en = 0$ ) OR ( $roiN\_binning\_en = 0$  AND  $color\_en = 1$ )

For ROI 1

$$ROI\_height = 2 \times \left[ INT\left(\frac{4 \times roi1\_h\_1}{roi1\_subs\_factor + 8}\right) + INT\left(\frac{4 \times roi1\_h\_2}{roi1\_subs\_factor + 8}\right) \right]$$

For ROI 2, 3 and 4:

$$ROI\_height = 2 \times INT\left(\frac{4 \times roiN\_h}{roiN\_subs\_factor + 8}\right)$$

If  $roiN\_binning\_en = 1$  AND  $color\_en = 1$

For ROI 1:

$$ROI\_height = 4 \times \left[ INT\left(\frac{2 \times roi1\_h\_1}{roi1\_subs\_factor + 8}\right) + INT\left(\frac{2 \times roi1\_h\_2}{roi1\_subs\_factor + 8}\right) \right]$$

For ROI 2, 3 and 4:

$$ROI\_height = 4 \times \left[ INT\left(\frac{2 \times roiN\_h}{roiN\_subs\_factor + 8}\right) \right]$$

Then, **height\_out** is:

$$\rightarrow height\_out = \frac{ROI\_height - 4 \times ddc\_en}{2^{roiN\_binning\_en}}$$

**Notes:**

- INT( ) takes the integer part of the division result.
- N stands for ROI index (1, 2, 3 or 4).
- If defect correction is active, the minimum ROI size is 5; defect correction must be disabled for smaller ROI size.

#### 4.5.4 Multi-ROI

The multi-ROI offers two different and separate modes:

- **MIMR (Multiple Integration Multiple ROI) mode** allows the user to define an acquisition cycle comprising 1 to 4 ROI cycle(s) (see *roi\_max\_id* in *<reg\_chain\_cfg>* in Section 17.3.7).
- **SIMR (Single Integration Multiple ROI) mode** acts on the first ROI of the multi-ROI cycle only, allows 1, 2 or 4 areas of interest to be acquired within the same integrated image. In SIMR mode, the sensor outputs only the configured zones and concatenates them to form a single image (see Section 4.5.4.2).

Each ROI has its own specific parameters (see Table 4-2) and parameters that are common to all ROIs (see Table 4-3).

**Table 4-2.** ROI-specific parameters

Parameter	Description	Register bitfield names			
		ROI1	ROI2	ROI3	ROI4
ROI Configuration	Defines the ROI dimensions and position in the total field of view.	<i>roi1_0l_1</i> <i>roi1_h_1</i> <i>roi1_0c_1</i> <i>roi1_w_1</i> <i>roi1_0l_2</i> <i>roi1_h_2</i> <i>roi1_0c_2</i> <i>roi1_w_2</i> in <i>&lt;reg_roi1*&gt;</i> , see Section 17.3.11	<i>roi2_0l_1</i> <i>roi2_h_1</i> <i>roi2_0c_1</i> <i>roi2_w_1</i> in <i>&lt;reg_roi2*&gt;</i> , see Section 17.3.12	<i>roi3_0l_1</i> <i>roi3_h_1</i> <i>roi3_0c_1</i> <i>roi3_w_1</i> in <i>&lt;reg_roi3*&gt;</i> , see Section 17.3.13	<i>roi4_0l_1</i> <i>roi4_h_1</i> <i>roi4_0c_1</i> <i>roi4_w_1</i> in <i>&lt;reg_roi4*&gt;</i> , see Section 17.3.14
Integration times	For each ROI two integration times have to be defined, one in number of lines and one in sub-line times.	<i>roi1_t_int_ll</i> <i>roi1_t_int_clk</i> in <i>&lt;reg_roi1*&gt;</i> , see Section 17.3.11	<i>roi2_t_int_ll</i> <i>roi2_t_int_clk</i> in <i>&lt;reg_roi2*&gt;</i> , see Section 17.3.12	<i>roi3_t_int_ll</i> <i>roi3_t_int_clk</i> in <i>&lt;reg_roi3*&gt;</i> , see Section 17.3.13	<i>roi4_t_int_ll</i> <i>roi4_t_int_clk</i> in <i>&lt;reg_roi4*&gt;</i> , see Section 17.3.14
Analog and digital gains		<i>roi1_ana_gain</i> <i>roi1_dig_gain</i> in <i>&lt;reg_roi1*&gt;</i> , see Section 17.3.11	<i>roi2_ana_gain</i> <i>roi2_dig_gain</i> in <i>&lt;reg_roi2*&gt;</i> , see Section 17.3.12	<i>roi3_ana_gain</i> <i>roi3_dig_gain</i> in <i>&lt;reg_roi3*&gt;</i> , see Section 17.3.13	<i>roi4_ana_gain</i> <i>roi4_dig_gain</i> in <i>&lt;reg_roi4*&gt;</i> , see Section 17.3.14
Vertical and horizontal sub-sampling factors		<i>roi1_subs_v</i> <i>roi1_subs_h</i> in <i>&lt;reg_roi1*&gt;</i> , see Section 17.3.11	<i>roi2_subs_v</i> <i>roi2_subs_h</i> in <i>&lt;reg_roi2*&gt;</i> , see Section 17.3.12	<i>roi3_subs_v</i> <i>roi3_subs_h</i> in <i>&lt;reg_roi3*&gt;</i> , see Section 17.3.13	<i>roi4_subs_v</i> <i>roi4_subs_h</i> in <i>&lt;reg_roi4*&gt;</i> , see Section 17.3.14

**Table 4-2.** ROI-specific parameters (Continued)

Parameter	Description	Register bitfield names			
		ROI1	ROI2	ROI3	ROI4
Binning factor	Binning is performed after the sub-sampling if this is used. Each ROI can have its own binning factor. See Section 9.	<i>roi1_binning_en</i> in <i>&lt;reg_chain_cfg&gt;</i> , see Section 17.3.7	<i>roi2_binning_en</i> in <i>&lt;reg_chain_cfg&gt;</i> , see Section 17.3.7	<i>roi3_binning_en</i> in <i>&lt;reg_chain_cfg&gt;</i> , see Section 17.3.7	<i>roi4_binning_en</i> in <i>&lt;reg_chain_cfg&gt;</i> , see Section 17.3.7
Repetition count	Each ROI will be repeated several times before reading the next ROI.	<i>roi1_rep_nb</i> in <i>&lt;reg_roi1*&gt;</i> , see Section 17.3.11	<i>roi2_rep_nb</i> in <i>&lt;reg_roi2*&gt;</i> , see Section 17.3.12	<i>roi3_rep_nb</i> in <i>&lt;reg_roi3*&gt;</i> , see Section 17.3.13	<i>roi4_rep_nb</i> in <i>&lt;reg_roi4*&gt;</i> , see Section 17.3.14
Wait time	Wait time after the end of the last ROI repetition (see Figure 4-7 Multi-ROI cycle).	<i>roi1_t_wait_ext</i> in <i>&lt;reg_roi1*&gt;</i> , see Section 17.3.11	<i>roi2_t_wait_ext</i> in <i>&lt;reg_roi2*&gt;</i> , see Section 17.3.12	<i>roi3_t_wait_ext</i> in <i>&lt;reg_roi3*&gt;</i> , see Section 17.3.13	<i>roi4_t_wait_ext</i> in <i>&lt;reg_roi4*&gt;</i> , see Section 17.3.14

All the used ROIs use these common parameters:

**Table 4-3.** ROI common parameters

Parameter	Description	Register bitfield names
Binning factor divider	The binning result may be divided by 1, 2 or 4 to either keep the maximum amount of information or reduce the noise.	<i>binning_div_factor</i> in <i>&lt;reg_chain_cfg&gt;</i> , see Section 17.3.7
Flip configuration	(see Figure 4-4: Flip effect)	<i>roi_flip_h</i> and <i>roi_flip_v</i> in <i>&lt;reg_miscel2&gt;</i> , see Section 17.3.4
Readout mode		<i>roi_readout_mode</i> , see Section 17.3.8
Digital color gains (For color sensor)		<i>gb_dig_gain</i> ; <i>gr_dig_gain</i> ; in <i>&lt;reg_dig_gain_gb_gr&gt;</i> , see Section 17.3.16 <i>b_dig_gain</i> ; <i>r_dig_gain</i> in <i>&lt;reg_dig_gain_b_r&gt;</i> , see Section 17.3.15
Wait time at the end of each frame		<i>roi_t_wait</i> , see Section 17.3.10
Line length		<i>line_length</i> , see Section 17.3.1
Clamp configuration and offsets	Depends on MIMR, SIMR or High dynamic configuration. See Section 4.5.4.1, Section 4.5.4.2 and Section 4.5.4.3	



4.5.4.1 Multiple Integration (MIMR) Mode Configuration

Figure 4-7. Multi-ROI cycle in MIMR mode

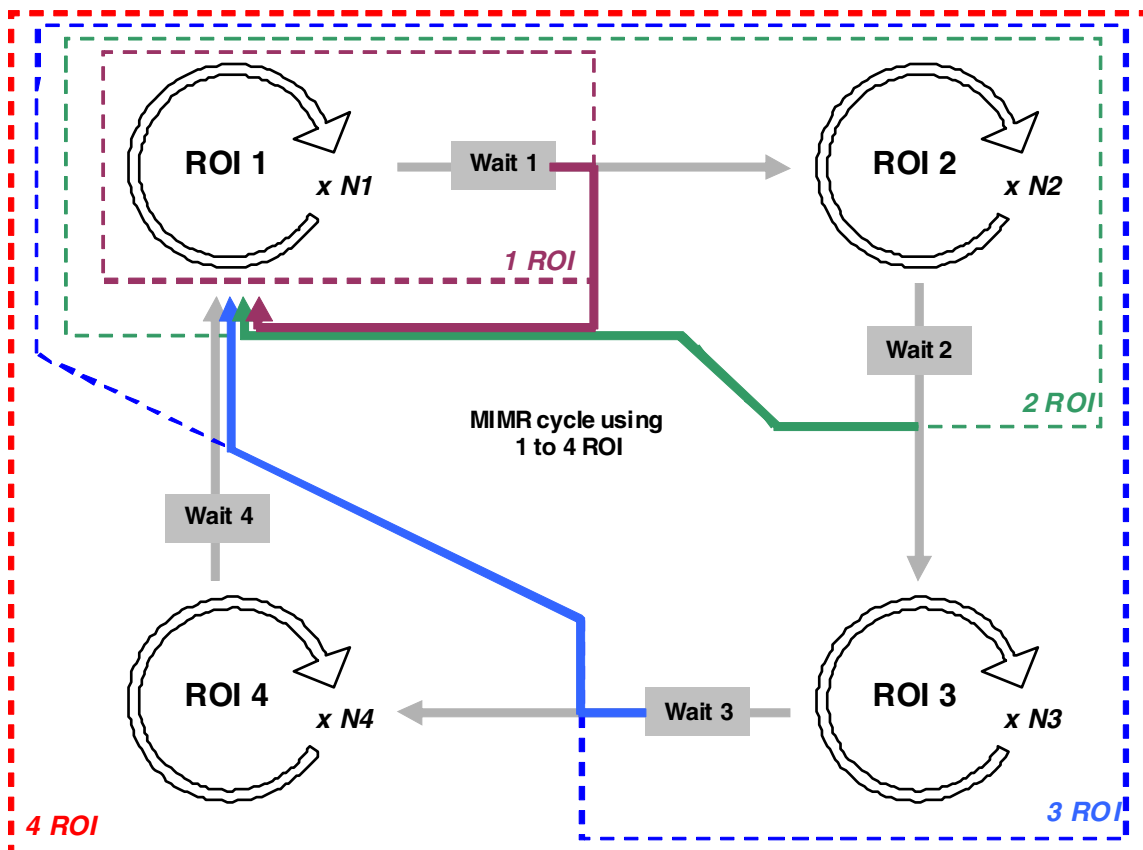

## 4.5.4.2 Single Integration (SIMR) Mode Configuration

Figure 4-8. SIMR parameters

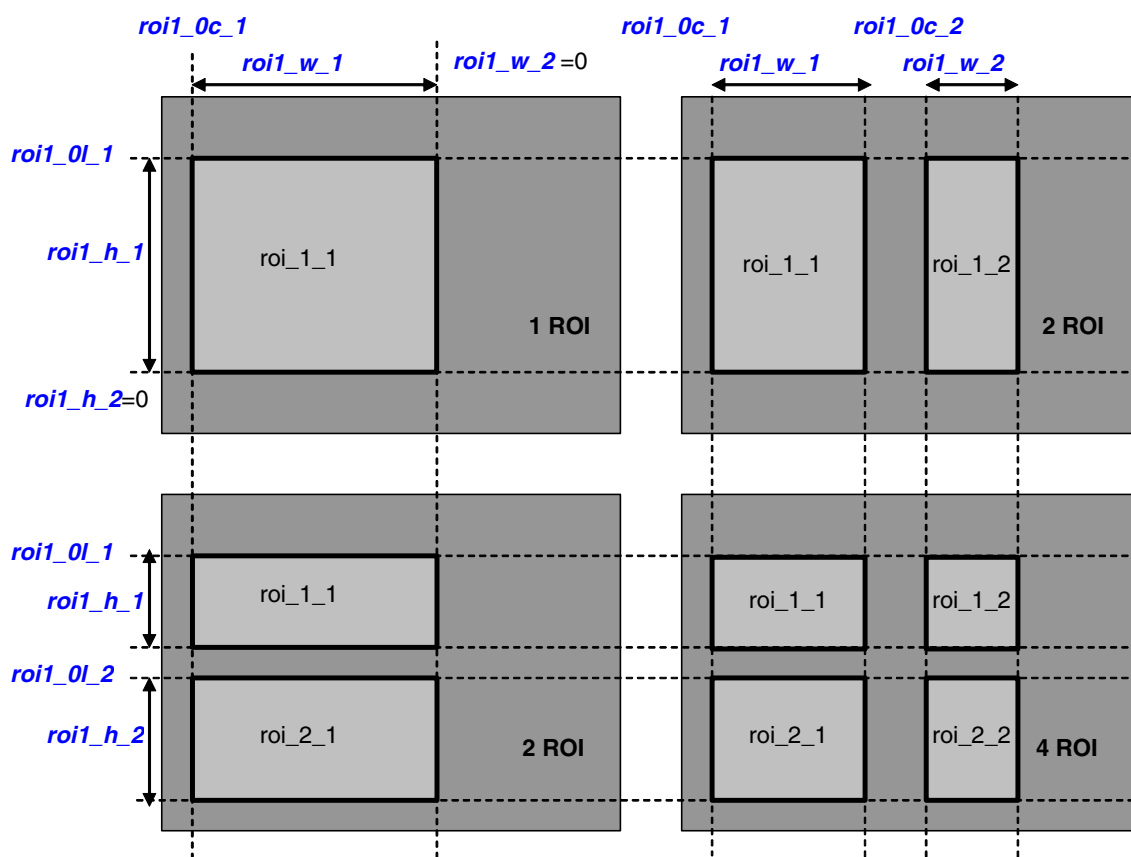

All the ROI 1 registers are described in [Section 17.3.11](#).

- If the ROI\_1\_2 width and ROI\_2\_1 height are null, only ROI\_1\_1 is read. The user has to choose:
  - ROI\_1\_1 horizontal (*roi1\_0c\_1*) and vertical (*roi1\_0l\_1*) offsets.
  - ROI\_1\_1 horizontal (*roi1\_w\_1*) and vertical (*roi1\_h\_1*) dimensions.
- If the ROI\_1\_2 width is greater than 0 and ROI\_2\_1 height is null, only ROI\_1\_1 and ROI\_1\_2 are read. The user has to choose:
  - ROI\_1\_1 horizontal (*roi1\_0c\_1*) and vertical (*roi1\_0l\_1*) offsets.
  - ROI\_1\_1 horizontal (*roi1\_w\_1*) and vertical (*roi1\_h\_1*) dimensions.
  - ROI\_1\_2 horizontal (*roi1\_0c\_2*) offset. (ROI\_1\_2 vertical offset = ROI\_1\_1).
  - Horizontal (*roi1\_w\_2*) width (ROI\_1\_2 height = ROI\_1\_1).
- If the ROI\_1\_2 width is null and ROI\_2\_1 height is greater than 0, only ROI\_1\_1 and ROI\_2\_1 are read. The user has to choose:
  - ROI\_1\_1 horizontal (*roi1\_0c\_1*) and vertical (*roi1\_0l\_1*) offsets.
  - ROI\_1\_1 horizontal (*roi1\_w\_1*) and vertical (*roi1\_h\_1*) dimensions.
  - ROI\_2\_1 vertical (*roi1\_0l\_2*) offset. (ROI\_2\_1 horizontal offset = ROI\_1\_1).

- ROI\_2\_1 height (*roi1\_h\_2*) (ROI\_2\_1 width is the same as ROI\_1\_1).
- If the ROI\_1\_2 width and ROI\_2\_1 height are greater than 0, then 4 ROI\_1\_1, ROI\_2\_1, ROI\_1\_2 and ROI\_2\_2 are read. The user has to choose:
  - ROI\_1\_1 horizontal (*roi1\_0c\_1*) and vertical (*roi1\_0l\_1*) offsets.
  - ROI\_1\_1 horizontal (*roi1\_w\_1*) and vertical (*roi1\_h\_1*) dimensions.
  - ROI\_2\_1 ROI\_2\_2 vertical (*roi1\_0l\_2*) offset and (*roi1\_h\_1*) height.
  - ROI\_1\_2 horizontal (*roi1\_0c\_2*) offset and (*roi1\_w\_2*) width.

**Figure 4-9.** ROI output for the "4 ROI" configuration

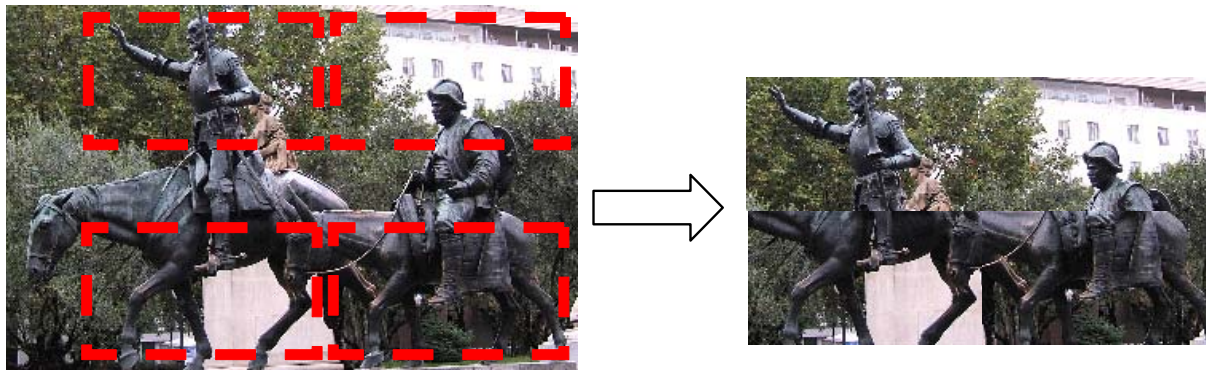

When using the defect correction (*roi\_ddc\_en* = 1) there is:

- A 4-column (or 2 if binning function is enabled) black border between ROI\_1\_1 and ROI\_1\_3 and ROI\_1\_2 and ROI\_1\_4.
- A 4-line (or 2 if binning function is enabled) black border between ROI\_1\_1 and ROI\_1\_2 and ROI\_1\_3 and ROI\_1\_4.

#### 4.5.4.3 High Dynamic Range Configuration

A special MIMR configuration using two integration times can be used to provide high dynamic images.

The first integration time image followed by a second integration image are combined without any image loss. For example:

- Image 1 with a short integration time
- Image 2 with N time longer integration time
- A computed image may be calculated by summing image 2 + [image 1 with each of its pixel values multiplied by N]

Note that due to the 60 fps maximum frame rate a true 30 fps output can be achieved.

In this mode only two ROIs are used. They must have the same:

- Position and dimensions.
- Binning
- Sub-sampling factor
- Repetition factor (=1)
- ROI mode (SIMR must not be used)

To prevent motion distortion it is recommended to perform the short integration time first.

**Figure 4-10.** Dual integration time mode for high dynamic  
High dynamic image

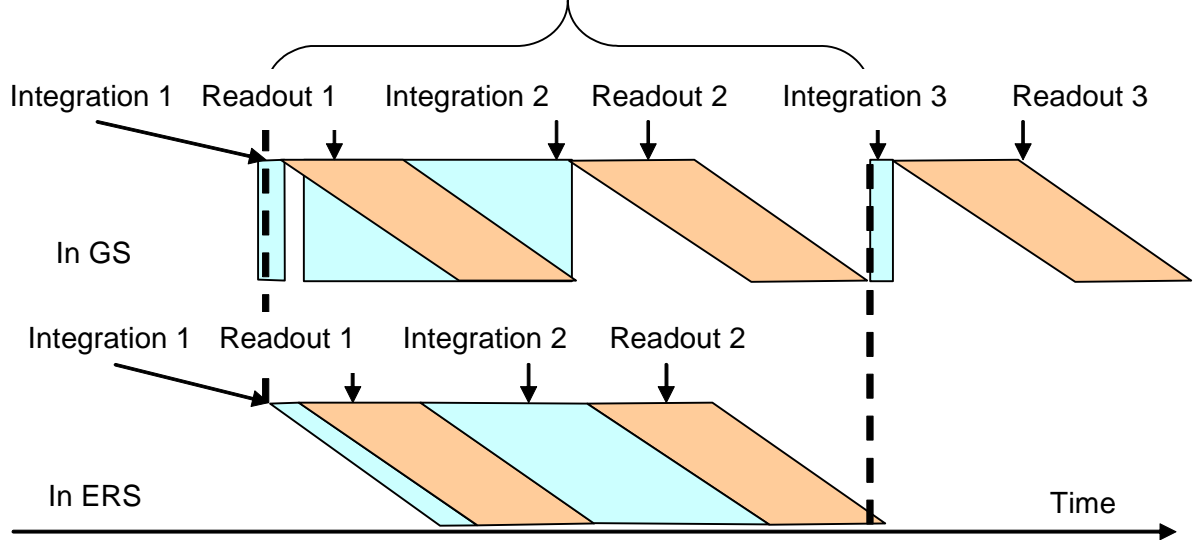

## 5. 10-Bit ADC

### 5.1 Analog Gain

Digital conversion is done by a high speed 10-bit column ADC. All the pixel values of the same line are converted in parallel.

The analog gain is done by a slope adjustment. There are 8 available values. These values are programmable via SPI. Each ROI has its own analog gain:

- *roi1\_ana\_gain* in `<reg_roi1*>` for ROI 1 (see Section 17.3.11)
- *roi2\_ana\_gain* in `<reg_roi2*>` for ROI 2 (see Section 17.3.12)
- *roi3\_ana\_gain* in `<reg_roi3*>` for ROI 3 (see Section 17.3.13)
- *roi4\_ana\_gain* in `<reg_roi4*>` for ROI 4 (see Section 17.3.14)

Figure 5-1. Principle of the column ADC

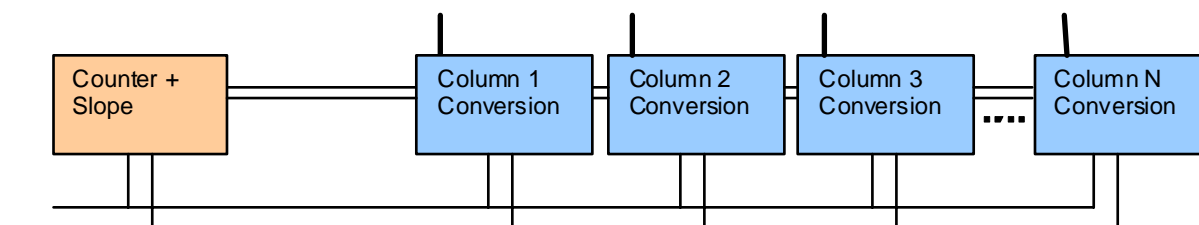
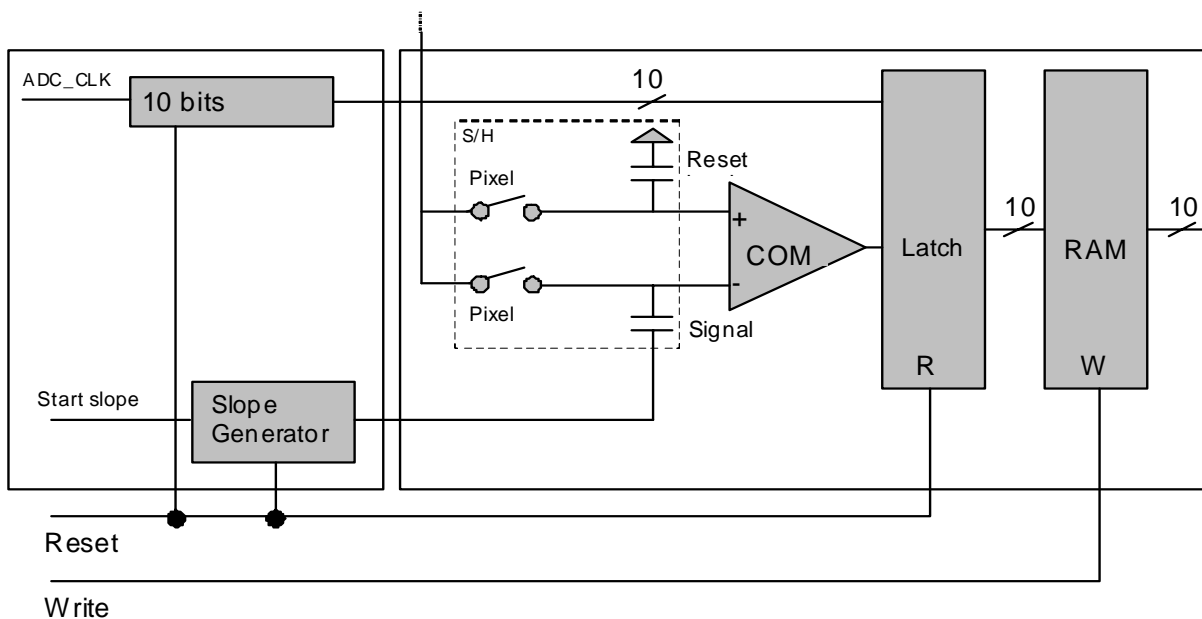

Figure 5-2. ADC schematic diagram



## 5.2 External Resistor Choice

The ADC gain value is set through an external resistor connected between ADC\_REF\_1 and ADC\_REF\_2 pins. An internal protection against a short circuit between these two pins is included in the design.

$$R_{EXT} = \frac{K}{CLK\_ADC} - 80$$

where  $K = 1.94 \times 10^{12}$ , CLK\_ADC is in Hertz and  $R_{EXT}$  is in Ohms.

With a 114 MHz ADC clock, the resistor value is 16.9 k $\Omega$ .

## 5.3 Analog Gain Tolerances

**Table 5-1.** ADC gain tolerances

1	1.5	2	3	4	6	8
89.09	59.09	44.18	29.64	22.30	14.90	11.27
Precision	0.5%	1%	1%	1%	1	2%

## 6. Clamp and Offset Adjustment

The purpose of the automatic black level adjustment function (or clamp) is to cancel:

- The offset due to pixel dark current (offset variable with temperature and integration time).
- The analog chain offset (mainly due to comparator offset).

The black level adjustment is active up to 65 °C with 200 ms integration time.

Black level adjustment can be automatic or manual. This is selected by the *clamp\_auto\_en* bit in the [<reg\\_miscel2>](#) register. See [Section 17.3.4](#)

In order to compensate possible differences in dark current generation between masked pixels and useful pixels, the automatic black level correction works as follows:

Figure 6-1. Clamp principle

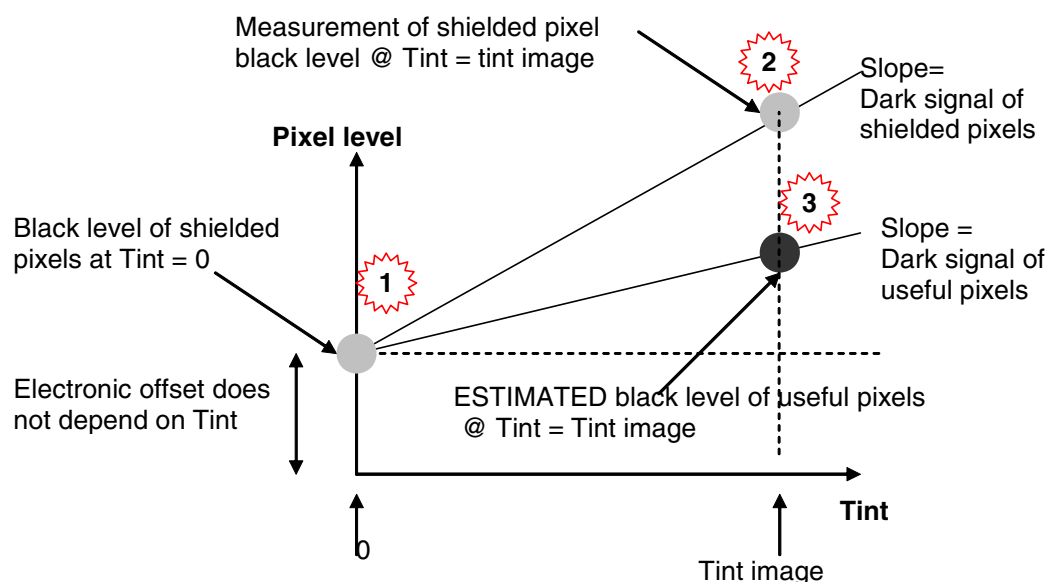

For each frame acquisition:

1. A first measurement is taken on a shielded pixel with a very short integration time (fixed to the minimum possible time) to determine the hardware offset of the acquisition chain (`chain_offset`).
2. A second measurement is taken to determine the dark signal mean value of a shielded pixel for the configured integration time (`shld_pix_level`).
3. The dark signal of a useful pixel is deduced from these 2 measurements and from the ratio between useful and shielded pixels (`V0_ratio`). This ratio is configurable via the `v0_gain` bit field in the `<reg_clamp_cfg>` register. See Section 17.3.18.

$$\text{Useful dark signal} = (\text{shielded pixel level} - \text{chain offset}) \times V0\_ratio + \text{chain offset}$$

A lock mechanism guarantees a constant correction offset as long as the difference between the new correction offset and the current correction is less than a threshold configurable by `clamp_lock_th` in `<reg_clamp_cfg>` see Section 17.3.18. This mechanism is necessary to ensure offset stability during a video stream. It can be bypassed using `clamp_lock_en` in `<reg_clamp_cfg>`, see Section 17.3.18.

Offset can be adjusted using either `clamp_add_offset` (if `clamp_auto_en` = '1' in `<reg_miscel2>`) or `clamp_manual_offset` (if `clamp_auto_en` = '0' in `<reg_miscel2>`) in `<reg_clamp_offset>`, see Section 17.3.17.

The `flag_dig_cor` flag in the `<fb_status>` register indicates if a digital correction is needed or not, see Section 17.3.23.

If the analog correction allowed by `<max_offset>` is saturated, a digital correction can be activated by setting `<dig_cor_en>`.

If `<dig_cor_en>` = 1 and analog offset is saturated, then the maximum data output level will be limited.

Digital and analog offsets are output in two feedback bitfields *fb\_ana\_offset* and *fb\_dig\_offset* in *<fb\_clamp>*, see Section 17.3.22.

Figure 6-2. Clamp algorithm

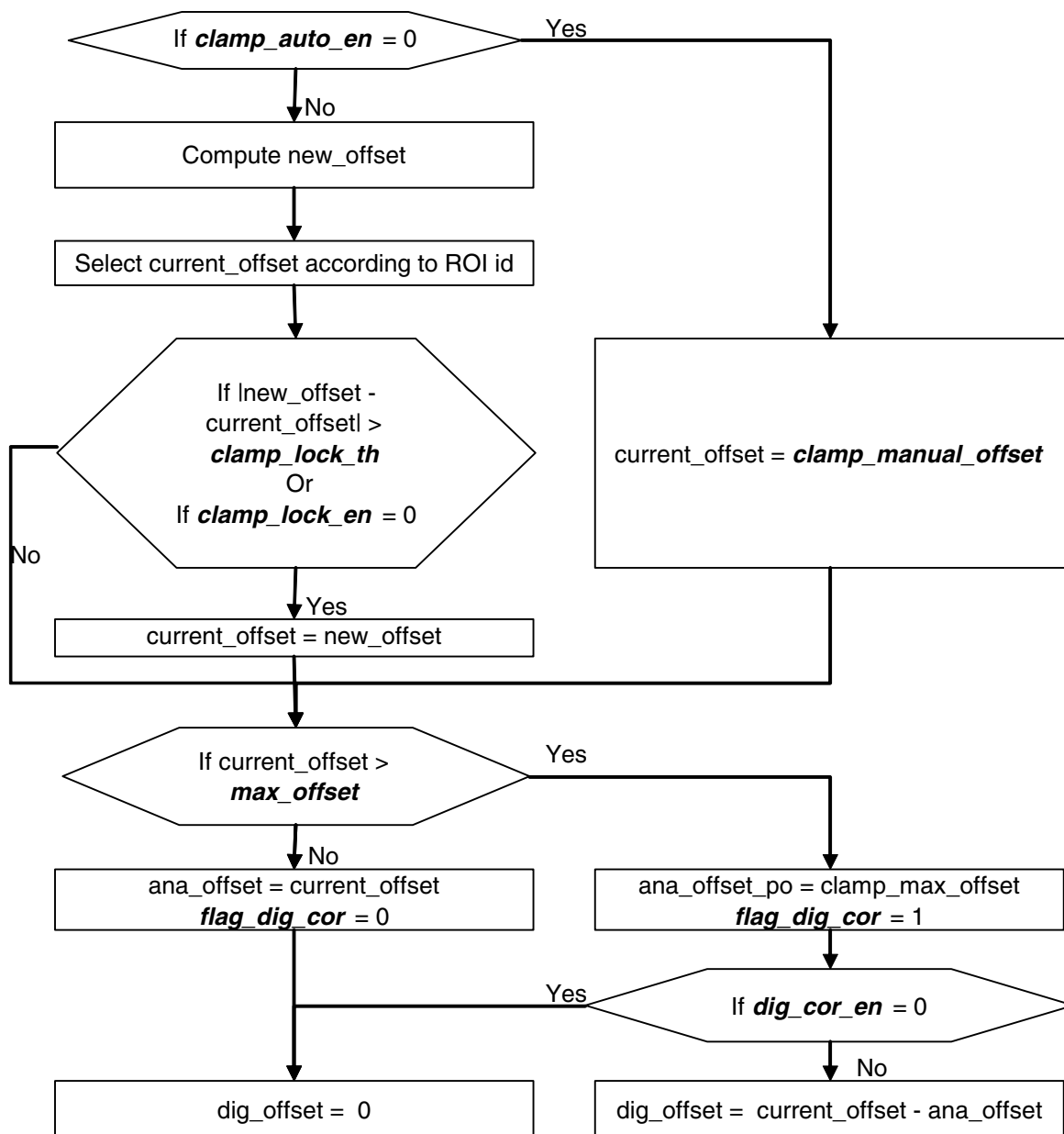



## 7. Digital Gain

This block applies one global gain followed by four digital gains (for the Bayer or WRGB CFA structures) configurable by 8-bit SPI registers.

In B&W products, only the global gain is used.

To allow good precision with low gains the 8-bits for programming the digital gain are used as follows:

- The 2 MSB are used for precision P
- The 6 LSB are used to control the gain G (from 0 to 63)
- The ROIX digital gains ([roiX\\_dig\\_gain](#)) follow this rule:

$$Gain = 2^P \times \left( 1 + \frac{G}{64} \right)$$

- For P=0 Gain varies from 1 to 1.98 in steps of 0.015
- For P=1 Gain varies from 2 to 3.97 in steps of 0.031
- For P=2 Gain varies from 4 to 7.94 in steps of 0.062
- For P=3 Gain varies from 8 to 15.88 in steps of 0.125

In color products, the four digital gains can be used to balance the four color channels (blue, green blue, green red and red):

- The 2 MSB are used for precision P
- The 6 LSB are used to control the gain G (from 0 to 63)
- The four digital color gains ([gb\\_dig\\_gain](#); [gr\\_dig\\_gain](#); [b\\_dig\\_gain](#); [r\\_dig\\_gain](#)) follow this rule:

$$Gain = 2^{P-2} \times \left( 1 + \frac{G}{64} \right)$$

- For P=0 Gain varies from 0.25 to 0.5 in steps of 0.004
- For P=1 Gain varies from 0.5 to 0.99 in steps of 0.008
- For P=2 Gain varies from 1 to 1.98 in steps of 0.016
- For P=3 Gain varies from 2 to 3.97 in steps of 0.031

## 8. Defective Pixel Correction

A multidirectional 3x3 median filter (with maximal weighting) is implemented and can be enabled by programming [roi\\_ddc\\_en](#) in [<reg\\_chain\\_cfg>](#). See [Section 17.3.7](#).

This filter is compatible with B&W and color products (Bayer or WRGB). All pixels of the ROI are corrected; this correction deletes 2 pixels all around the input picture so the ROI output is reduced by 2 pixels in each line and column. See [Section 4.5.3](#).

## 9. Binning

Two binning 2x2 modes are implemented:

**Figure 9-1.** B&W binning (color\_en=0)



$$P_{bin} = \frac{1}{k} \sum_{i=1}^4 P_i$$

The k parameter, see [binning\\_div\\_factor](#), allows dividing the sum by 1, 2 or 4.

**Figure 9-2.** Color binning (color\_en=1)

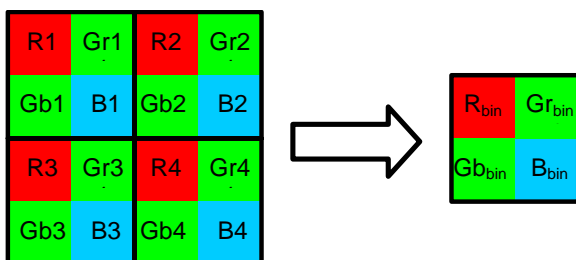

$$X_{bin} = \frac{1}{k} \sum_{i=1}^4 X_i$$

With X = B, Gb, Gr or R.

The k parameter, see [binning\\_div\\_factor](#), allows dividing the sum by 1, 2 or 4.

The binning respects the Bayer pattern to add only the same color pixels.

When k= 4 → Average by 4 → Saturation remains the same and noise on the image is reduced by a factor 2.

When k=2 or 1, the sum is clipped at the value 1023.

The dimensions of the binning output image are half the input image dimensions.

## 10. Histograms

Four histograms can be computed (for color sensors):

- The first one with green blue pixels
- The second one with red pixels
- The third one with blue pixels
- The fourth one with green red pixels

To enable histogram calculation program *roi\_histo\_en* in *<reg\_chain\_cfg>*, see [Section 17.3.7](#).

The number of categories is selectable: 8, 16, 32 or 64 using *hist\_bin\_nb* in *<reg\_chain\_cfg>*. See [Section 17.3.7](#).

The histograms are output (see [Figure 12-1 on page 29](#)) with the number of bright pixels first.

Each category is coded on 16 bits and output on the 8 MSB of two successive pixels.

The 4 histograms are output serially without any delimiter.

The number of saturated pixels at zero and at 1023 are calculated and provided to the application in the footer. See [Section 12](#).

**Figure 10-1.** Histogram outputs

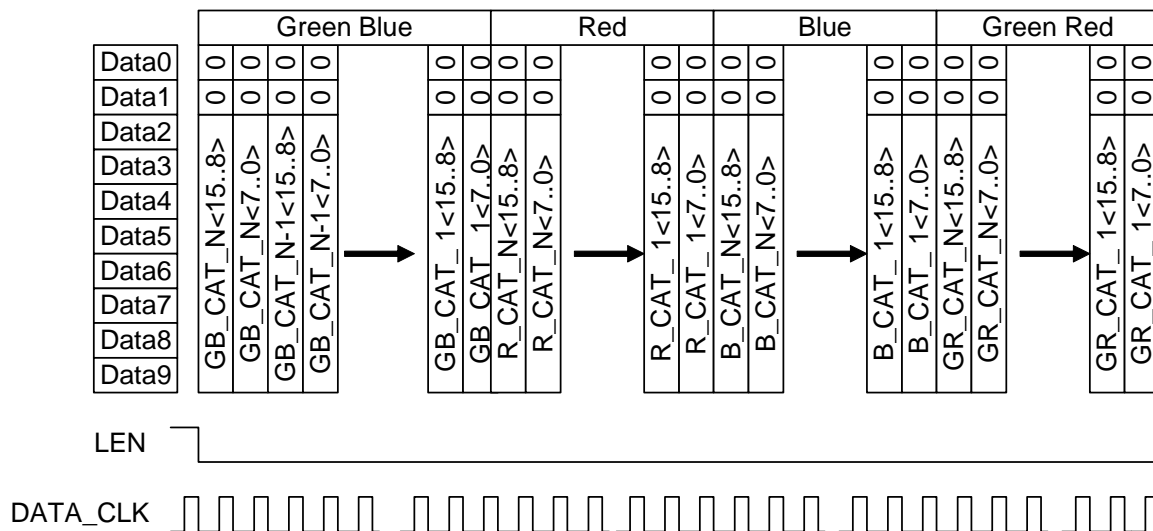

## 11. 10 to 8-Bit Compression

To allow the use of 8-bit output, the amplitude range is redefined with 256 levels.

8 data bits are output on the 8 MSB.

The transfer function is defined as follows:

- The user has to choose the knee point  $K_N$  by programming *range\_coeff* in `<reg_miscel1>`.
- The output value on 8 bits follows these rules:

$$\text{For } 0 \leq IN < K_N \quad \longrightarrow \quad OUT = IN$$

$$\text{For } K_N \leq IN < 8 \cdot \left(128 - \frac{3}{4} K_N\right) \quad \longrightarrow \quad OUT = \frac{IN}{4} + \frac{3}{4} K_N$$

$$\text{For } 8 \cdot \left(128 - \frac{3}{4} K_N\right) \leq IN < 1024 \quad \longrightarrow \quad OUT = \frac{IN}{8} + 128$$

Figure 11-1. 10 to 8 bit compression

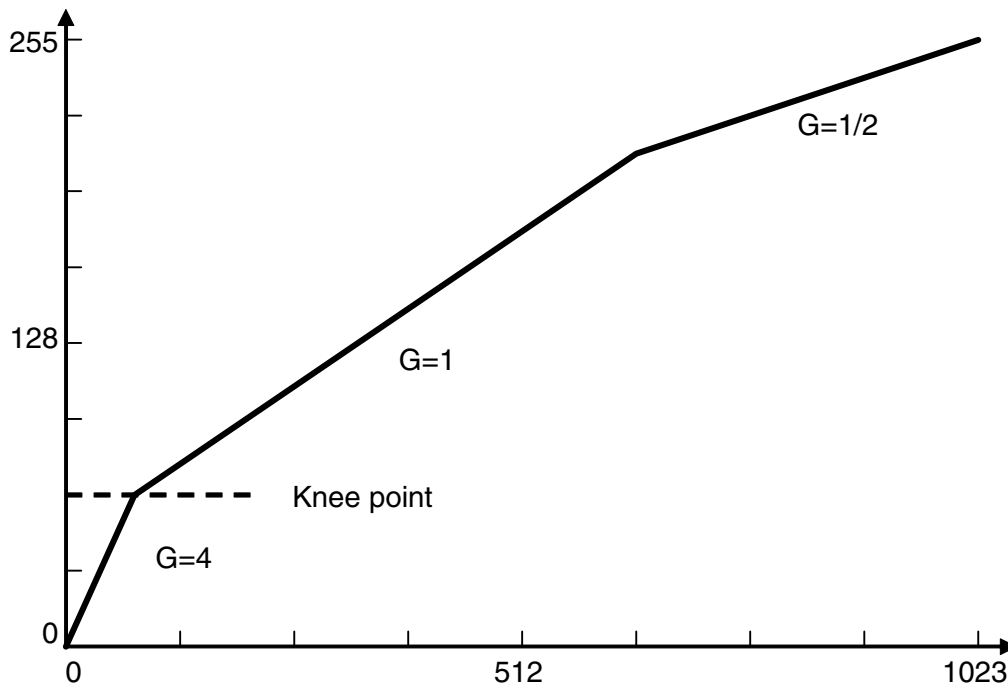

To enable this function use *range\_en* in `<reg_chain_cfg>` see Section 17.3.7.

Using a knee point at 0 will only output the 8 MSB of 10-bit values to the 8 MSB of the output without any compression.

## 12. Context

This block inserts in the data stream the configuration of the sensor used for the current image.

Insertion image context is under SPI control. See [roi\\_context\\_out\\_en](#) in [<reg\\_chain\\_cfg>](#) in [Section 17.3.7](#).

Each image has its own header and footer.

The context data may be output with or without a histogram output.

Context data are output on the first line and on the last line inside the FEN signal. The context is output as extra lines. If the stream is too long for the LEN (due to a small ROI) the output of the stream is not cut by the change of LEN state. This means that even for the context output the LEN duration is the same for the whole image comprising context and histograms.

Depending on [mask\\_idle\\_data](#) in [<reg\\_miscel2>](#) if the useful line length is too short, data may be truncated.

The data are output on the 8 MSB of the video output (the 2 LSB are left at 00).

[Figure 12-1](#) shows the location of the header and histogram data in the final frame structure:

**Figure 12-1.** Header and histogram

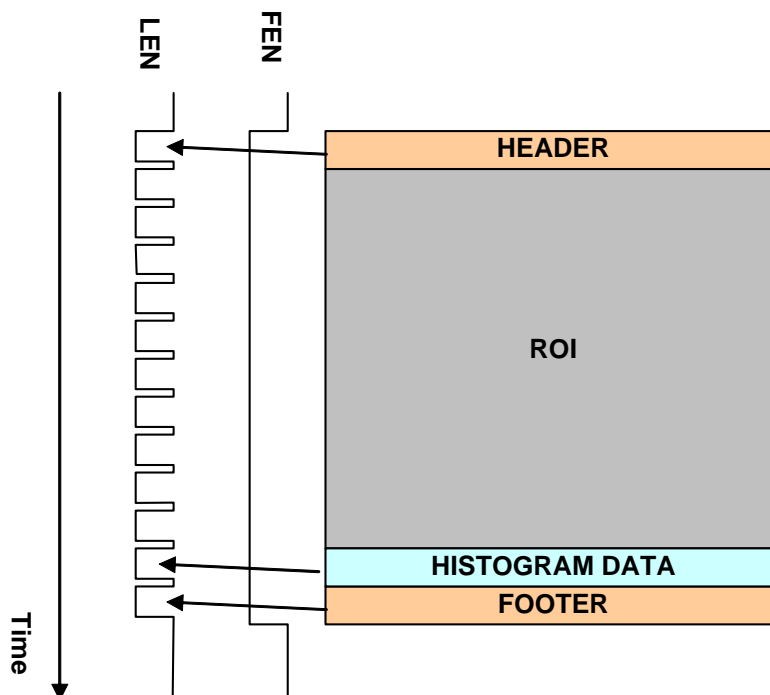

**Table 12-1.** Header content

Word count	Name	Description
0	"000000" & roi_id	ROI id (from 1 to 4)
1	roi_nb	ROI number (on 8-bit number of the readout image of this ROI)
2	"00000" & read_roi_0c_1[10:8]	Address of first column (MSB)
3	read_roi_0c_1[7:0]	Address of first column (LSB)

Table 12-1. Header content (Continued)

Word count	Name	Description
4	"00000" & read_roi_0l_1[10:8]	Address of first line (MSB)
5	read_roi_0l_1[7:0]	Address of first line (LSB)
6	"00000" & roi_width[10:8]	ROI width (MSB)
7	roi_width[7:0]	ROI width (LSB)
8	"00000" & roi_height[10:8]	ROI Height (MSB)
9	roi_height[7:0]	ROI Height (LSB)
10	t_int_ll[15:8]	Main ROI integration time in line (MSB)
11	t_int_ll[7:0]	Main ROI integration time in line (LSB)
12	"00" & t_int_clk[13:8]	MSB of extra ROI integration time in CLK_CTRL × <i>t_int_clk_mult_factor</i>
13	t_int_clk[7:0]	LSB of extra ROI integration time in CLK_CTRL × <i>t_int_clk_mult_factor</i>
14	analog_gain	ROI analog gain
15	dig_gain_glob	ROI Global digital gain
16	dig_gain_b	Blue digital gain
17	dig_gain_gb	Green blue digital gain
18	dig_gain_gr	Green red digital gain
19	dig_gain_r	Red digital gain
20	fb_ana_offset	Analog offset
21	fb_dig_offset	Digital offset
22	'0'	(MSB)
	fb_flag_dir_cor	See <a href="#">Section 17.3.23</a>
	fb_error_time_overflow	
	fb_error_corrupted_video	
	fb_error_ll_vs_xfer	
	fb_error_ll_vs_conv	
	fb_error_t_int_big	
	fb_error_t_int_small	
23	t_frame_period_actual[15:8]	Frame period (MSB)
24	t_frame_period_actual [7:0]	Frame period (LSB)
	"00..0"	Line is filled with extra 00

**Table 12-2.** Footer content

Word count	Name	Description
0	'0'	See sensor status feedback <a href="#">Section 17.3.23</a> .
	fb_flag_dir_cor	
	fb_error_time_overflow	
	fb_error_corrupted_video	
	fb_error_ll_vs_xfer	
	fb_error_ll_vs_conv	
	fb_error_t_int_big	
	fb_error_t_int_small	
1	low_sat_nb[15:8]	Number of pixels at 0 value (MSB)
2	low_sat_nb[7:0]	Number of pixels at 0 value (LSB)
3	high_sat_nb[15:8]	Number of pixels at 1023 value (MSB)
4	high_sat_nb[7:0]	Number of pixels at 1023 value (LSB)
	"00..0"	Line is filled with extra 00

### 13. Mux Out

This block multiplexes the different signals to the output: video, context and histograms.

### 14. Timing Generator and Power Management

Under SPI control, the timing generator provides the necessary timing to the sensor. It manages the different read modes depending on the global states programmed by the application. It times the reading of the matrix to follow the ROI, binning and sub-sampling functions.

## 15. Clock Generator

The application has to provide 1 or 2 clocks to the sensor:

- The reference clock (CLK\_REF).
- A second stable clock (CLK\_FIX) if the application needs to dither CLK\_REF to improve EMC performance.

Two other clocks are available in the sensor:

- CLK\_OSC which is generated by an internal oscillator.
- CLK\_PLL which is output by the PLL with CLK\_REF as the reference clock.

These four clocks are the sensor input clocks.

**Figure 15-1.** Clock management

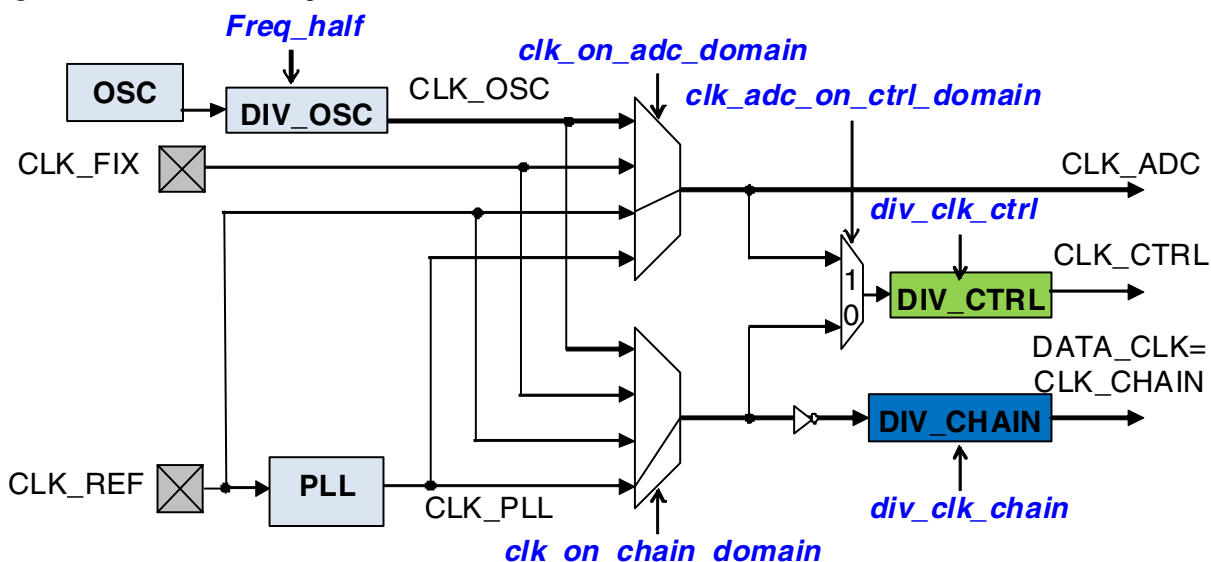

The sensor needs three different clocks for three separate domains (See [Figure 2-1: Block Diagram](#)):

- One for the ADC (CLK\_ADC).
- One for the timing control (CLK\_CTRL).
- One for the digital chain (CLK\_CHAIN).

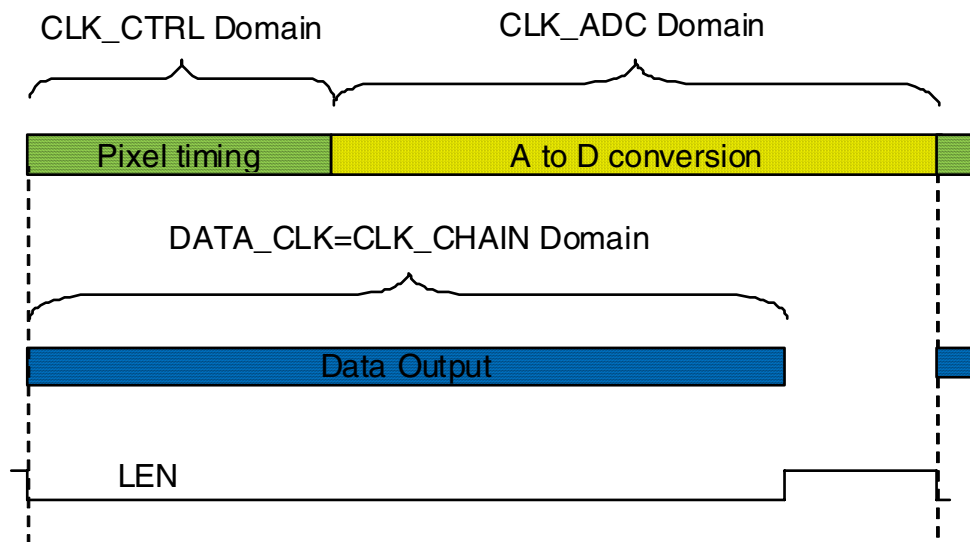

Figure 15-2. Clock domains

**Notes:**

CLK\_ADC and CLK\_CTRL must be stable. Clock dithering is not allowed except for CLK CHAIN which may be dithered for EMC reasons if needed.

Pixel timing duration is given in [Section 19.5](#).

A to D conversion and data output durations are computed in [Section 19.4](#).

## 15.1 PLL

A Phase-Locked Loop block (PLL) is embedded to provide an output frequency (CLK\_PLL) from a reference frequency (CLK\_REF). The PLL supports a dithered CLK\_REF. (See [Figure 15-1](#): Clock management).

If the PLL is not used, the block is in power down mode.

### 15.1.1 Register used

[pll\\_od](#), [pll\\_n](#) and [pll\\_fb](#) in [<Reg\\_pll\\_cfg>](#) see [Section 17.3.6](#).

The PLL output frequency CLK\_PLL is given by the equation:

$$CLK\_PLL = \frac{M}{N \times P} \times CLK\_REF$$

With:

$$4 < M = 2x(pll\_fb + 1) < 512,$$

$$2 < N = 2x(pll\_n + 1) < 20,$$

$$P(pll\_od) = 4$$

$$5 \text{ MHz} < CLK\_REF < 50 \text{ MHz}.$$

Figure 15-3. PLL block diagram

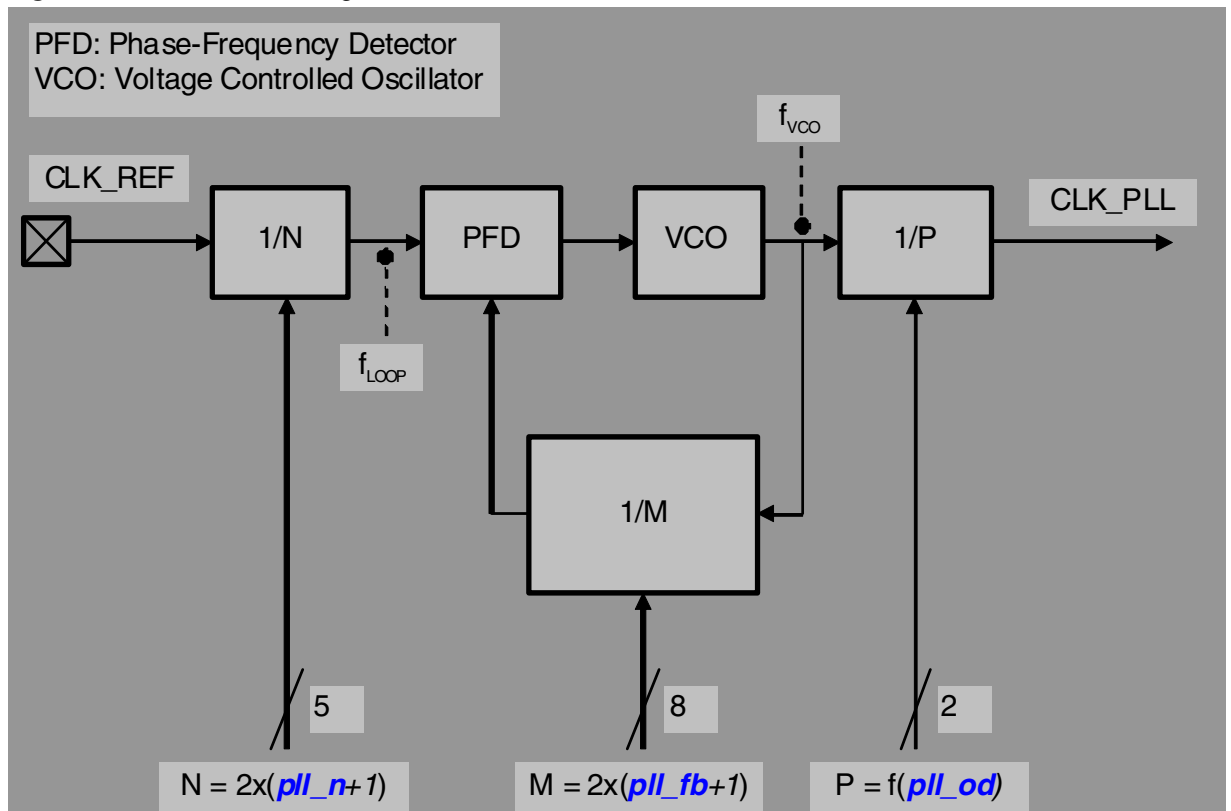

### 15.1.2 Limits and Conditions

The following conditions and limits must be respected to allow the PLL to operate efficiently:

- $325 \text{ MHz} < f_{VCO} = \text{CLK\_PLL} \times P < 480 \text{ MHz}$
- $2.5 \text{ MHz} < f_{LOOP}$
- $81.25 \text{ MHz} < \text{CLK\_PLL} < 120 \text{ MHz}$

### 15.1.3 PLL Factor Calculations

For a given input frequency (CLK\_REF) and the desired output frequency (CLK\_PLL), follow these steps to calculate the pll\_fb, pll\_n and pll\_od parameters.

1. Calculation of pll\_od:  
–  $\text{pll\_od} = 4$
2. Calculation of pll\_n:

$$\text{pll\_n} = \text{Integer Part} \left( \frac{\text{CLK\_REF}}{5} \right) - 1$$

3. Calculation of pll\_fb:

$$\text{pll\_fb} = 2 \times \text{RoundedUp} \left( \frac{(\text{pll\_n}+1) \times \text{CLK\_PLL} \times \text{pll\_od}}{\text{CLK\_REF}} \right) - 1$$

4. Calculation of the real CLK\_PLL:

The above formulas can be used to calculate the PLL output frequency (CLK\_PLL).

The following table gives the some frequency calculation examples showing the P,N and M parameter settings used to obtain a 114 MHz system frequency with different input reference frequencies. The VCO frequency is 456 MHz.

**Table 15-1.** Example of PLL parameter settings to obtain 114 MHz CLK\_PLL output frequency

Parameter settings	CLK_REF input frequency		
	12 MHz	24 MHz	48 MHz
P	4	4	4
<i>pll_od</i>	h03	h03	h03
N	4	8	18
<i>pll_n</i>	h01	h03	h08
M	152	152	172
<i>pll_fb</i>	h4B	h4B	h55

## 15.2 Internal Oscillator

The internal oscillator has to be calibrated by the application. During the calibration procedure the sensor counts the number of CLK\_OSC cycles during the calibration reference period *calib\_count\_ref*. The length of *calib\_count\_ref* is defined by the user as a number of CLK\_REF cycles. The number of CLK\_OSC cycles can be read in the *fb\_calib\_count\_osc* register when the *flag\_reg\_calib\_count\_ref* flag goes back to low level.

If needed the oscillator frequency can be adjusted using *prg\_osc\_freq\_adjust* in <reg\_prg\_osc> see Section 17.3.19.

<freq\_half> may be used to divide the internal oscillator frequency by 2.

The internal oscillator frequency can be computed using the formula below, where  $R_{EXT}$  is the ADC\_REF external resistor:

$$\text{Frequency} = \frac{1}{\left[ \frac{R_{EXT} \times 316 (10^{-13})}{36 + \text{prg\_osc\_freq\_adjust}} \right] + 3.4 (10^{-9})}$$

Figure 15-4. Oscillator calibration

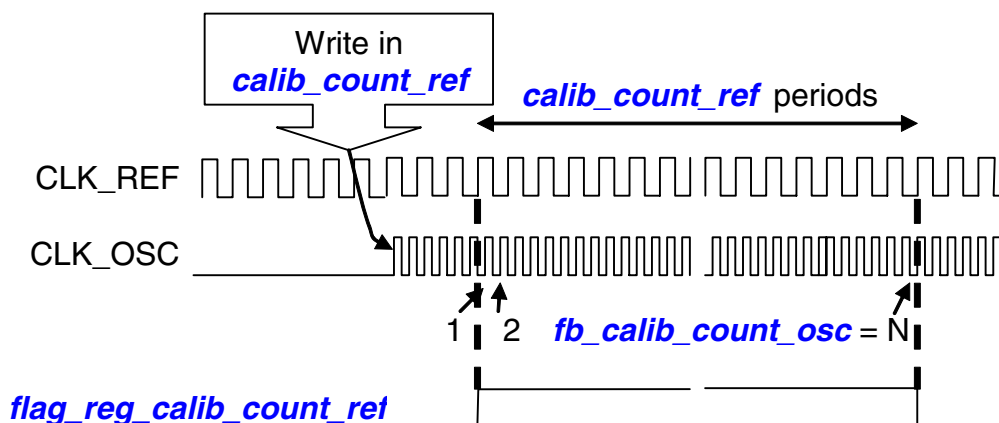

### 15.3 Nominal Clock Configurations

CLK\_OSC is used for A to D conversion (CLK\_ADC) and pixel timing (CLK\_CTRL) with a DIV\_CTRL = 2

CLK\_PLL is used for the digital chain (CLK\_CHAIN).

The typical clock configuration is as follows:

*clk\_on\_adc\_domain* = h2 in <reg\_clk\_cfg> see Section 17.3.5

*clk\_on\_ctrl\_domain* = h1 in <reg\_clk\_cfg> see Section 17.3.5

*clk\_on\_chain\_domain* = h3 in <reg\_clk\_cfg> see Section 17.3.5

*div\_clk\_chain* = h2 in <reg\_clk\_cfg> see Section 17.3.5

With this configuration a dithered clock can be used as CLK\_REF for the PLL.

To allow the maximum frame rate, CLK\_OSC must be above 114 MHz.

## 16. Test Pattern Generator

A test pattern allows the signal processing to be checked. It generates repeated slope from 0 to 1023 with a 1 LSB step.

The timing and image size used in this mode uses the ROI and timing configuration.

The block generates 3 different patterns.

### 16.1 Moving Test Pattern

*pattern\_type* = 01

In this mode, the test pattern changes from line to line and from frame to frame.

Figure 16-1 gives examples for a ROI (52 × 188 pixels). If the ROI width or height is larger than 1024 the test pattern counter will create additional ramp pulses in both directions.

Figure 16-1. Moving test pattern

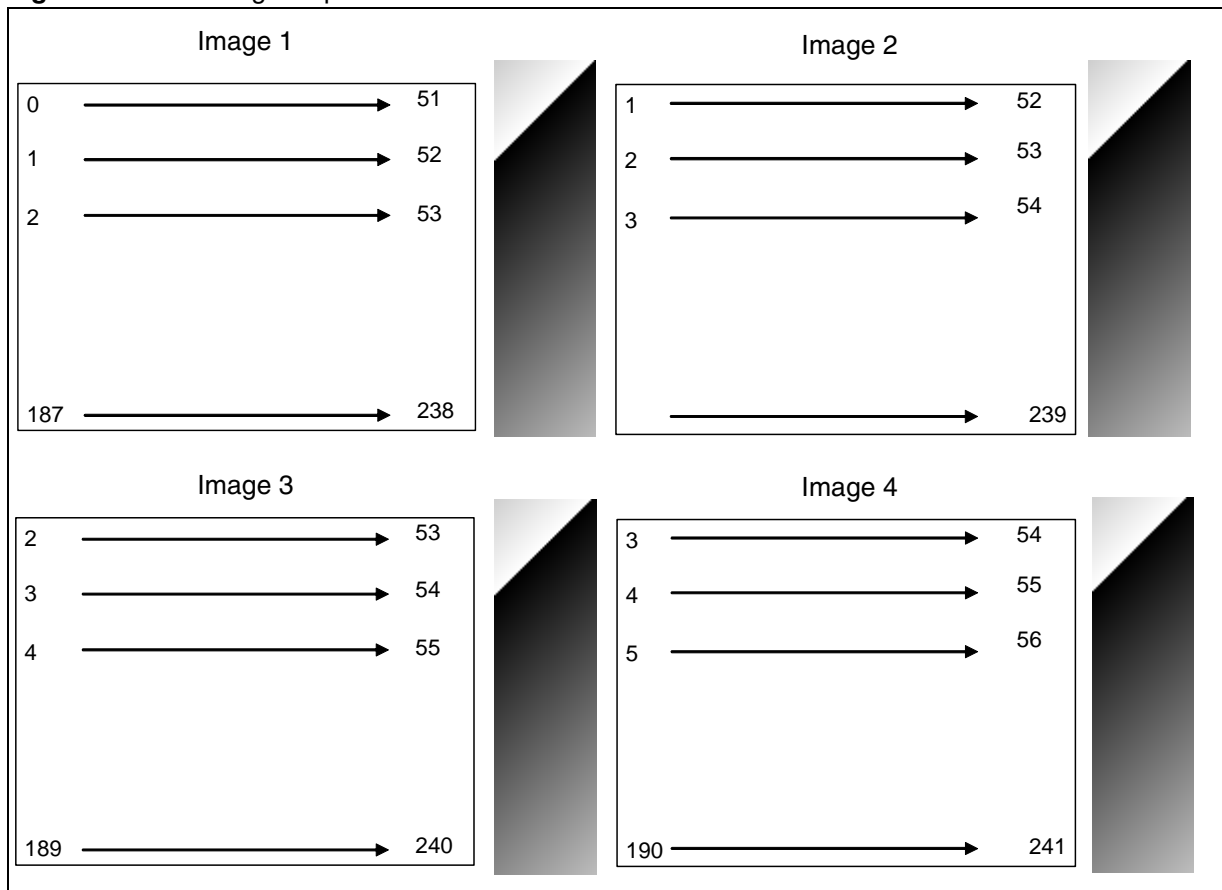

## 16.2 Fixed Test Pattern

*pattern\_type* = 10

Figure 16-2 shows this pattern, using the same resolution as the previous example. The test pattern ramp generator will always have the same starting point at 0, at the first pixel of the first line.

**Figure 16-2.** Fixed test pattern example

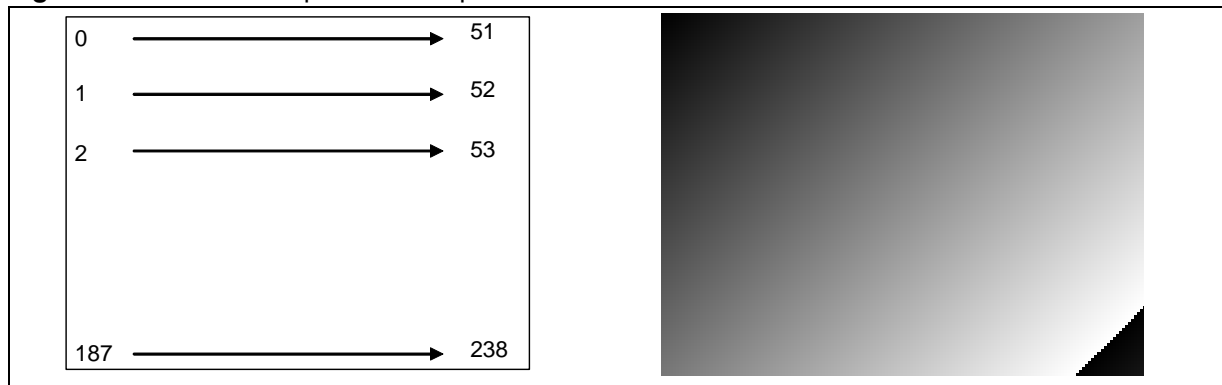

## 16.3 Functional Test Pattern

*pattern\_type* = 11

This test pattern allows all output values to occur in the smallest possible image. The test pattern counter counts only during active FEN and LEN. The first pixel of the first line is at 0.

Figure 16-3 gives an example of a  $16 \times 16$  image.

**Figure 16-3.** Functional test pattern

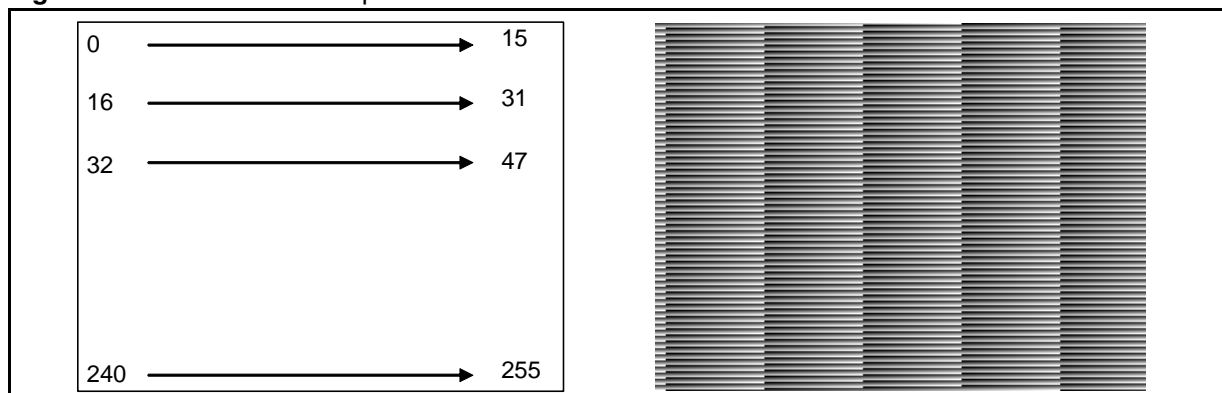

## 17. SPI

The SPI communication interface allows the sensor to be controlled by an external device (SPI mode 0).

Most built-in functions are configurable via SPI registers. We can distinguish 6 types of registers:

- Dynamic registers (D) are read/write registers. They are refreshed only one time per frame at the beginning of the readout or on matrix reset, depending on the selected readout mode. A lock mechanism allows the refresh to be disabled. This is useful for ensuring that several register changes are taken into account in the same frame.
- Mailbox registers (MBX) are read/write registers. They are used to send abort requests or read calibration status information.
- Reset registers (RST) are read/write registers. They are used to perform a soft reset of the device.
- Static registers (S) are read/write registers. Any change in their value is taken into account immediately.
- Restricted static registers (RS) are like static registers but they must be modified only in STANDBY or IDLE state. Any change in their value during an acquisition sequence may have an unpredictable effect.
- Feedback registers (F) are read only registers. They are used to report the current state of the sensor.

### 17.1 Register Summary Tables

**Table 17-1.** 8-bit registers

Addr (hex)	Register Name	Type	Width	Bit	Content	Reference section	
0000	reg0	rs	8	7:0	Burst mode	<a href="#">Section 17.2.1</a>	<a href="#">Section 17.4</a>
0001	reg_soft_reset	rst	8	7:0	Soft reset global command	<a href="#">Section 17.2.2</a>	
0002	calib_mbx	mbx	1	0	flag_reg_calib_count_ref	<a href="#">Section 17.2.3</a>	
0003	abort_mbx	mbx	1	0	flag_abort_mbx	<a href="#">Section 17.2.4</a>	

**Table 17-2.** 16-bit registers

Addr (hex)	Register Name	Type	Width	Bit	Content	Reference section	
0004	reg_line_cfg	rs	4	15:12	extra_line_nb	<a href="#">Section 17.3.1</a>	
			1	11	Reserved		
			11	10:0	line_length		
0005	reg_flash_delay	rs	8	15:8	t_flash_del_off	<a href="#">Section 17.3.2</a>	<a href="#">Section 19.6</a>
			8	7:0	t_flash_del_on		

Table 17-2. 16-bit registers (Continued)

Addr (hex)	Register Name	Type	Width	Bit	Content	Reference section	
0006	reg_miscel1	rs	8	15:8	max_offset		
			8	7:0	range_coeff		Section 11.
0007	reg_miscel2	rs	1	15	reserved	Section 17.3.4	
			1	14	sync_flo_inv		Section 19.6
			1	13	sync_len_inv		
			1	12	sync_fen_inv		
			1	11	mask_idle_data		
			1	10	color_en		
			1	9	clamp_auto_en		Section 6.
			1	8	roi_expanded		
			1	7	roi_flip_h		Section 4.5.1
			1	6	roi_flip_v		
0008	reg_clk_cfg	rs	2	5:4	pattern_type	Section 17.3.5	Section 16.
			4	3:0	vlr_ph_ctrl		
			1	15	clk_chain_low_pwr		
			1	14	clk_out_inv		
			1	13	freq_half		
			1	12	clk_on_ctrl_domain		Section 15.
			2	11:10	clk_on_adc_domain		
2	9:8	clk_on_chain_domain					
0009	reg_pll_cfg	rs	4	7:4	div_clk_ctrl	Section 17.3.6	Section 15.1
			4	3:0	div_clk_chain		
			2	14:13	pll_od		
			5	12:8	pll_n		
			8	7:0	pll_fb		



Table 17-2. 16-bit registers (Continued)

Addr (hex)	Register Name	Type	Width	Bit	Content	Reference section	
000A	reg_chain_cfg	d	2	15:14	t_int_clk_mult_factor	Section 17.3.7	
			2	13:12	roi_max_id		Section 4.5.4
			2	11:10	hist_bin_nb		Section 10.
			2	9:8	binning_div_factor		Section 9.
			1	7	roi_context_out_en		Section 12.
			1	6	roi_histo_en		
			1	5	roi_ddc_en		Section 8.
			1	4	range_en		Section 11.
			1	3	roi4_binning_en		Section 4.5.3
			1	2	roi3_binning_en		
			1	1	roi2_binning_en		
000B	reg_ctrl_cfg	rs	1	13	dum_stdby_en	Section 17.3.8	
			1	12	dum_pwrup_en		
			1	11	dum_img_out_en		
			1	10	lock_dyn_reg		
			1	9	trig_pad_inv		
			1	8	trig_pad_sel		
			2	7:6	roi_flash_mode		Section 19.6
			2	5:4	roi_readout_mode		Section 18.2
			1	3	roi_video_en		Section 18.2.5
			1	2	roi_overlap_en		Section 18.2
			1	1	trig_rqst		
1	0	stdby_rqst	Section 18.1.2				
000C	reg_t_frame_period	d	16	15:0	t_frame_period	Section 17.3.9	
000D	reg_t_wait	d	16	15:0	t_wait	Section 17.3.10	

Table 17-2. 16-bit registers (Continued)

Addr (hex)	Register Name	Type	Width	Bit	Content	Reference section	
000E	reg_roi1_t_int_ll	d	16	15:0	roi1_t_int_ll	Section 17.3.11	Section 4.5.4
000F	reg_roi1_rep_nb_t_int_clk	d	8	15:8	roi1_rep_nb		
			8	7:0	roi1_t_int_clk		
0010	reg_roi1_t_wait_ext	d	11	10:0	roi1_t_wait_ext		
0011	reg_roi1_gain	d	3	10:8	roi1_ana_gain		
			8	7:0	roi1_dig_gain		
0012	reg_roi1_0l_1	d	11	10:0	roi1_0l_1		
0013	reg_roi1_h_1	d	11	10:0	roi1_h_1		
0014	reg_roi1_0c_1	d	11	10:0	roi1_0c_1		
0015	reg_roi1_w_1	d	11	10:0	roi1_w_1		
0016	reg_roi1_0l_2	d	11	10:0	roi1_0l_2		
0017	reg_roi1_h_2	d	11	10:0	roi1_h_2		
0018	reg_roi1_0c_2	d	11	10:0	roi1_0c_2		
0019	reg_roi1_w_2	d	11	10:0	roi1_w_2		
001A	reg_roi1_subs	d	8	15:8	roi1_subs_v	Section 4.5.3	
			8	7:0	roi1_subs_h		
001B	reg_roi2_t_int_ll	d	16	15:0	roi2_t_int_ll	Section 17.3.12	Section 4.5.4
001C	reg_roi2_rep_nb_t_int_clk	d	8	15:8	roi2_rep_nb		
			8	7:0	roi2_t_int_clk		
001D	reg_roi2_t_wait_ext	d	11	10:0	roi2_t_wait_ext		
001E	reg_roi2_gain	d	3	10:8	roi2_ana_gain		
			8	7:0	roi2_dig_gain		
001F	reg_roi2_0l_1	d	11	10:0	roi2_0l_1		
0020	reg_roi2_h_1	d	11	10:0	roi2_h_1		
0021	reg_roi2_0c_1	d	11	10:0	roi2_0c_1		
0022	reg_roi2_w_1	d	11	10:0	roi2_w_1		
0023	reg_roi2_subs	d	8	15:8	roi2_subs_v		
			8	7:0	roi2_subs_h		

Table 17-2. 16-bit registers (Continued)

Addr (hex)	Register Name	Type	Width	Bit	Content	Reference section	
0024	reg_roi3_t_int_ll	d	16	15:0	roi3_t_int_ll	Section 17.3.13	Section 4.5.4
0025	reg_roi3_rep_nb_t_int_clk	d	8	15:8	roi3_rep_nb		
			8	7:0	roi3_t_int_clk		
0026	reg_roi3_t_wait_ext	d	11	10:0	roi3_t_wait_ext		
0027	reg_roi3_gain	d	3	10:8	roi3_ana_gain		
			8	7:0	roi3_dig_gain		
0028	reg_roi3_0l_1	d	11	10:0	roi3_0l_1		
0029	reg_roi3_h_1	d	11	10:0	roi3_h_1		
002A	reg_roi3_0c_1	d	11	10:0	roi3_0c_1		
002B	reg_roi3_w_1	d	11	10:0	roi3_w_1		
002C	reg_roi3_subs	d	8	15:8	roi3_subs_v	Section 4.5.3	
			8	7:0	roi3_subs_h		
002D	reg_roi4_t_int_ll	d	16	15:0	roi4_t_int_ll	Section 17.3.14	Section 4.5.4
002E	reg_roi4_rep_nb_t_int_clk	d	8	15:8	roi4_rep_nb		
			8	7:0	roi4_t_int_clk		
002F	reg_roi4_t_wait_ext	d	11	10:0	roi4_t_wait_ext		
0030	reg_roi4_gain	d	3	10:8	roi4_ana_gain		
			8	7:0	roi4_dig_gain		
0031	reg_roi4_0l_1	d	11	10:0	roi4_0l_1		
0032	reg_roi4_h_1	d	11	10:0	roi4_h_1		
0033	reg_roi4_0c_1	d	11	10:0	roi4_0c_1		
0034	reg_roi4_w_1	d	11	10:0	roi4_w_1		
0035	reg_roi4_subs	d	8	15:8	roi4_subs_v	Section 4.5.3	
			8	7:0	roi4_subs_h		
0036	reg_dig_gain_gb_gr	d	8	15:8	gb_dig_gain	Section 17.3.15	9
			8	7:0	gr_dig_gain		
0037	reg_dig_gain_b_r	d	8	15:8	b_dig_gain	Section 17.3.16	
			8	7:0	r_dig_gain		
0038	reg_clamp_offset	d	8	15:8	clamp_add_offset	Section 17.3.17	
			8	7:0	clamp_manual_offset		
0039	reg_clamp_cfg	rs	3	14:12	init_line_nb	Section 17.3.18	
			4	11:8	clamp_lock_th		
			1	7	clamp_lock_en		
			1	6	dig_cor_en		
			6	5:0	v0_gain		

Table 17-2. 16-bit registers (Continued)

Addr (hex)	Register Name	Type	Width	Bit	Content	Reference section
003A	reg_prg_osc	rs	7	15:9	prg_osc_vsate_adjust	Section 17.3.19
			2	8:7	prg_osc_vsate_select	
			7	6:0	prg_osc_freq_adjust	
003B	reg_calib_count_ref	rs	16	15:0	calib_count_ref	Section 17.3.20
003C	fb_calib_osc_count	f	16	15:0	fb_calib_count_osc	Section 17.3.21
003D	fb_clamp	f	8	15:8	fb_ana_offset	Section 17.3.22
			8	7:0	fb_dig_offset	
003E	fb_status	f	1	8	flag_dig_cor	Section 17.3.23
			2	7:6	fb_state_main_global	
			1	5	error_time_overflow	
			1	4	error_corrupted_video	
			1	3	error_ll_vs_xfer	
			1	2	error_ll_vs_conv	
			1	1	error_t_int_big	
1	0	error_t_int_small				
003F to 0048	reserved					
0049	pixtime_read_width	rs	8	15:8	pixtime_read_5t_width	Section 17.3.26
			8	7:0	pixtime_read_4t_width	
7F	Chip_ID	f	16	15:0	Chip ID	

## 17.2 8-Bit Register Descriptions

### 17.2.1 Register 0

<b>Name</b>	reg0
<b>Address</b>	h00
<b>Type</b>	Restricted static
<b>Default</b>	h01

Default Value	Bitfield name	Description
0000 0001	<i>reg0_0[7:0]</i>	Master clock divider: 0 → Normal mode active (no burst) 1 → Burst mode active

### 17.2.2 Soft Reset Register

<b>Name</b>	reg_soft_reset
<b>Address</b>	h01
<b>Type</b>	Reset
<b>Default</b>	h00

Default Value	Bitfield name	Description
0000 0000	<i>soft_reset[7:0]</i>	Soft reset Writing or reading in SPI address h01 resets the whole chip, except the SPI state machine

## 17.2.3 Calibration Mailbox

<b>Name</b>	calib_mbx
<b>Address</b>	h02
<b>Type</b>	Mailbox
<b>Default</b>	h00

Default Value	Bitfield name	Description
0000 0000	<i>flag_reg_calib_count_ref</i>	Oscillator calibration status <b>0</b> → Calibration sequence has ended (or not requested) <b>1</b> → Request was recorded. Calibration is ongoing. See reg_calib_count_ref in <a href="#">Section 17.3.20</a> .

## 17.2.4 Abort Mailbox

<b>Name</b>	abort_mbx
<b>Address</b>	h03
<b>Type</b>	Mailbox
<b>Default</b>	h00

Default Value	Bitfield name	Description
0000 0000	<i>flag_abort_mbx</i>	Abort request / Abort status A write access to flag_abort_mbx generates an abort request. A read access returns the following status. <b>0</b> → Abort has ended (or not requested) <b>1</b> → Request was recorded. Current sequence should stop within one line duration. The abort action is requested by a single write to the flag_abort_mbx register itself.

## 17.3 16-Bit Register Descriptions

### 17.3.1 Line Configuration

<b>Name</b>	reg_line_cfg
<b>Address</b>	h04
<b>Type</b>	Restricted static
<b>Default</b>	h8070

Default Value	Bitfield name	Description
1000 ---- ---- ----	<i>extra_line_nb[15:12]</i>	<p>Number of extra lines Defines the number of extra lines added after ROI readout</p> <p>Min = 0 → 1 line added <b>Default = h8 → 9 lines added</b> Max = hF → d16 lines added See <a href="#">Section 19.2.2</a>.</p>
---- 0--- ---- ----	<i>reserved</i>	
---- -000 0111 0000	<i>line_length[10:0]</i>	<p>Line length Defines the line length specified in CLK_CTRL cycles multiplied by 8 (timing examples below with CLK_CTRL = 57 MHz). <a href="#">Section 19.4</a> - Line length calculation.</p> <p>Min = 0 <b>Default = h70 → 15.72 μs</b> Max = h7FF → 287 μs</p>

## 17.3.2 Flash Delay

<b>Name</b>	reg_flash_delay
<b>Address</b>	h05
<b>Type</b>	Restricted static
<b>Default</b>	h0000

Default Value	Bitfield name	Description
0000 0000    ---- ----	<i>t_flash_del_off[7:0]</i>	Flash off delay Delay between end of active FLO and end of integration specified in $8 \times 1$ line. Min = 0 → No delay added Max = hFF → $255 \times 8 = 2040$ lines delay Note: <i>t_flash_del_off</i> must be lower than <i>roi&lt;i&gt;t_int_ll</i> (ex: @ h0E for ROI1).
---- ----    0000 0000	<i>t_flash_del_on[7:0]</i>	Flash on delay Delay between start of active FLO and start of integration specified in $8 \times 1$ line. Min = 0 → No delay added Max = hFF → $255 \times 8 = 2040$ lines delay Note: <ol style="list-style-type: none"> <li><i>t_flash_del_on</i> increases the frame period if <i>roi_overlap_en</i> (@ h0B) = 0.</li> <li>If <i>roi_readout_mode</i> (@ h0B) = 4T ERS, the applied delay will be the programmed delay + 2 lines.</li> </ol>

- Both flash delays are automatically set to 0 if *roi\_flash\_mode* (@ h0B) = 0 (= FLASH\_OFF).
- *t\_flash\_del\_off* is ignored if *roi\_flash\_mode* (@ h0B) = 3 (= FLASH\_ON).
- *t\_flash\_del\_off* should be set to 0 if *roi\_readout\_mode* (@ h0B) = 4T+ERS and *roi\_overlap\_en* (@ h0B) = 1. (If not, there is a risk of finding glitches in FLO).



## 17.3.3 Miscellaneous Register 1

<b>Name</b>	reg_miscel1
<b>Address</b>	h06
<b>Type</b>	Restricted static
<b>Default</b>	hD05A

Default Value	Bitfield name	Description
1101 0000    ---- ----	<i>max_offset[7:0]</i>	ADC max offset Maximum offset that can be applied to the ADC column (analogically). See <a href="#">Section 6</a> . and <a href="#">Section 19.4</a> . Min = 0 <b>Default → hD0 : Offset max 208 LSB</b> Max = hFF
---- ----    0101 1010	<i>range_coeff[7:0]</i>	10 to 8 bit knee point Defines the knee point for the 10 to 8 bit compression. Min = h00 → function with only 1 slope G=1 <b>Default = h5A → function with 3 slopes G=1/2 G=1 and G=4</b> Max = h92 → function with only 2 slopes G=4 and G=1/2 Note: This register is used only if range_en (@ h0A) = 1

## 17.3.4 Miscellaneous Register 2

<b>Name</b>	reg_miscl2
<b>Address</b>	h07
<b>Type</b>	Restricted static
<b>Default</b>	h0A01

Default Value	Bitfield name	Description
X--- ----	<i>reserved</i>	
-0-- ----	<i>sync_flo_inv</i>	FLO signal polarity <b>0 → FLO is not inverted (active high: FLO = 1 means that light may be turned on)</b> <b>1 → FLO is inverted (active low)</b>
--0- ----	<i>sync_len_inv</i>	LEN signal polarity <b>0 → LEN is not inverted (active low: LEN = 0 means that pixels are being output)</b> <b>1 → LEN is inverted (active high)</b>
---0 ----	<i>sync_fen_inv</i>	FEN signal polarity <b>0 → FEN is not inverted (active low: FEN = 0 means that pixels are being output)</b> <b>1 → FEN is inverted (active high)</b>
---- 1---	<i>mask_idle_data</i>	Mask idle data <b>0 → D0..D9 output data may change, whatever LEN value</b> <b>1 → if LEN is at inactive level then D0..D9 are set to 0</b>
---- -0--	<i>color_en</i>	Color mode selection <b>0 → B&amp;W mode</b> <b>1 → Color mode (with Bayer pattern)</b> This bit is used for defect correction, binning algorithms and for ROI size calculation. It must be set to 1 when using a color sensor.
---- --1-	<i>clamp_auto_en</i>	Auto clamp mode <b>0 → Black level adjustment has to be done manually</b> <b>1 → Enables automatic black level adjustment</b>
---- ---0	<i>roi_expanded</i>	ROI expanded mode <b>0 → Programmed ROI has its origin (0,0) in the first illuminated pixel of the physical matrix</b> <b>1 → Programmed ROI has its origin (0,0) in the first pixel of the physical matrix, including dark pixels (the 19 first black lines can be read at the beginning of the frame)</b> Note: If <i>roi_expanded</i> = 1, <i>clamp_auto_en</i> (bit 9) must be set at 0.

Default Value	Bitfield name	Description
----- 0-----	<i>roi_flip_h</i>	Horizontal flip enable <b>0 → No horizontal flip</b> 1 → Horizontal flip
----- -0-----	<i>roi_flip_v</i>	Vertical flip enable <b>0 → No vertical flip</b> 1 → Vertical flip
----- --00-----	<i>pattern_type[1:0]</i>	Test pattern type selection <b>00 → Video output</b> 01 → Diagonal grey scale pattern, moving (+1) on each image 10 → Diagonal grey scale pattern, still image with first pixel = 0 11 → Ramping pattern, with continuously incrementing pixel values
----- ---- 0001	<i>vlr_ph_ctrl[3:0]</i>	Logarithmic wide dynamic range control h0 → NOT allowed <b>h1 → linear response</b> h2 .. hF → controls the knee point between linear response and log response.

## 17.3.5 Clock Configuration

<b>Name</b>	reg_clk_cfg
<b>Address</b>	h08
<b>Type</b>	Restricted static
<b>Default</b>	hDB21

Default Value	Bitfield name	Description
1---- ----	<i>clk_chain_low_pwr</i>	CLK_CHAIN low power mode 0 → CLK_CHAIN active during whole acquisition (integration and readout) <b>1 → CLK_CHAIN active only for data readout</b>
-1-- ----	<i>clkout_inv</i>	Clock output polarity 0 → DATA_CLK rising edge is simultaneous with output data change <b>1 → DATA_CLK falling edge is simultaneous with output data change</b>
--0- ----	<i>freq_half</i>	Oscillator frequency divider <b>0 → Oscillator frequency not divided</b> 1 → Oscillator frequency is divided by 2 Note: If freq_half=1, the fb_calib_count_osc (@ h3C) counts the divided CLK_OSC period.
---1 ----	<i>clk_adc_on_ctrl_domain</i>	CLK_CTRL clock source selection Selects the clock source for CLK_CTRL (before division): 0 → CLK_CHAIN <b>1 → CLK_ADC</b>
---- 10--	<i>clk_on_adc_domain[1:0]</i>	CLK_ADC clock source selection Selects the clock source for CLK_ADC: 00 → Clock from CLK_FIX pad 01 → Clock from CLK_REF pad <b>10 → Clock from internal oscillator</b> 11 → Clock from PLL

Default Value	Bitfield name	Description
----- --11 -----	<i>clk_on_chain_domain</i> [1:0]	CLK_CHAIN clock source selection Selects the clock source for CLK_CHAIN: 00 → Clock from CLK_FIX pad 01 → Clock from CLK_REF pad 10 → Clock from internal oscillator <b>11 → Clock from PLL</b>
----- 0010 -----	<i>div_clk_ctrl</i> [3:0]	CLK_CTRL frequency divider Defines the clock division ratio applied to CLK_CTRL. Min = h0 or h1 → CLK_CTRL divided by DIV_CTRL = 1 <b>Default h2 → CLK_CTRL divided by DIV_CTRL = 2</b> Max hF → CLK_CTRL divided by DIV_CTRL = 15
----- 0001 -----	<i>div_clk_chain</i> [3:0]	CLK_CHAIN frequency divider Defines the clock division ratio applied to CLK_CHAIN. Min = h0 or h1 → CLK_CHAIN divided by DIV_CHAIN = 1 <b>Default h1 → CLK_CHAIN divided by DIV_CHAIN = 1</b> Max hF → CLK_CHAIN divided by DIV_CHAIN = 15

## 17.3.6 PLL Configuration

<b>Name</b>	reg_pll_cfg
<b>Address</b>	h09
<b>Type</b>	Restricted static
<b>Default</b>	h6125

Default Value	Bitfield name	Description
-11- ----	<i>pll_od[1:0]</i>	PLL P parameter 00 → P= 1 01 → P= 2 10 → Forbidden value 11 → P= 4
----0 0001	<i>pll_n[4:0]</i>	PLL N parameter $N = 2 \times (\text{pll\_n} + 1)$ Min → h00 : N = d2 <b>Default → h01 : N = d4</b> Max → h09 : N = d20
----- 0010 0101	<i>pll_fb[7:0]</i>	PLL M parameter $M = 2 \times (\text{pll\_fb} + 1)$ Min → h01 : M = d4 <b>Default → h25 : M = d76</b> Max → hFF : M = d512

## 17.3.7 CHAIN Configuration

<b>Name</b>	reg_chain_cfg
<b>Address</b>	h0A
<b>Type</b>	Dynamic
<b>Default</b>	h0200

Default Value	Bitfield name	Description
00-- ---- ----	<i>t_int_clk_mult_factor[1:0]</i>	Integration time multiplication factor Multiplication factor of the fractional part of integration time. <b>00 → x 8</b> 01 → x 16 10 → x 32 11 → x 64 Note: This parameter influences each roi<i>_t_int_clk (@h0F / @h1C ...)
--00 ---- ----	<i>roi_max_id[1:0]</i>	Number of ROIs Defines the maximum number of ROIs to read in MIMR mode. <b>00 → 1 ROI : ROI1</b> 01 → 2 ROIs : ROI1 & ROI2 10 → 3 ROIs : ROI1, ROI2 & ROI3 11 → 4 ROIs : ROI1, ROI2, ROI3 & ROI4
---- 00-- ----	<i>hist_bin_nb[1:0]</i>	Number of histogram bins Defines the maximum number of histogram bins: <b>00 → 64 / 1 = 64 bins</b> 01 → 64 / 2 = 32 bins 10 → 64 / 4 = 16 bins 11 → 64 / 8 = 8 bins (Warning, possible overflow) Note: Used only if roi_histo_en ON, in the same register
---- --10 ----	<i>binning_div_factor[1:0]</i>	Binning division factor Division factor of 4-pixel sum in binning mode 00 → 4-pixel sum divided by 1 01 → 4-pixel sum divided by 2 <b>10 → 4-pixel sum divided by 4</b> Note: Used only if roi<i>_binning_en is ON, in the same register

Default Value	Bitfield name	Description
----- 0-----	<i>roi_context_out_en</i>	Context output enable Enables context (header and footer) on output data <b>0 → No context available on output</b> <b>1 →</b> Enables context on output See Note 1.
----- -0----	<i>roi_histo_en</i>	Histogram calculation enable Enables histogram calculation on data stream <b>0 → No histogram calculation requested</b> <b>1 →</b> Enables histogram calculation See Note 1.
----- --0----	<i>roi_ddc_en</i>	Defect correction enable Enables defect correction on data stream <b>0 → No defect correction requested</b> <b>1 →</b> Enables defect correction
----- ---0----	<i>range_en</i>	Range compression enable Enables range compression on data stream <b>0 → No range compression requested</b> <b>1 →</b> Enables range compression Note: See <i>range_coef</i> (@ h06) to control range compression
----- ---- 0---	<i>roi4_binning_en</i>	ROI4 binning <b>0 → No binning requested on ROI4</b> <b>1 →</b> Enables binning on ROI4 See Note 1.
----- ---- -0--	<i>roi3_binning_en</i>	ROI3 binning <b>0 → No binning requested on ROI3</b> <b>1 →</b> Enables binning on ROI3 See Note 1.
----- ---- --0-	<i>roi2_binning_en</i>	ROI2 binning <b>0 → No binning requested on ROI2</b> <b>1 →</b> Enables binning on ROI2 See Note 1.
----- ---- ---0	<i>roi1_binning_en</i>	ROI1 binning <b>0 → No binning requested on ROI1</b> <b>1 →</b> Enables binning on ROI1 See Note 1.

**Note 1:** This parameter influences *extra\_line\_nb* (@ h04).



## 17.3.8 CTRL Configuration

<b>Name</b>	reg_ctrl_cfg
<b>Address</b>	h0B
<b>Type</b>	Mixed: Static (s) and Restricted Static (rs)
<b>Default</b>	h0005

Default Value	Bitfield name	Description
--0- ----	<i>rs dum_stdby_en</i>	Reserved, must be kept at 0
----0 ----	<i>rs dum_pwrup_en</i>	Reserved, must be kept at 0
---- 0---	<i>rs dum_img_out_en</i>	Reserved, must be kept at 0
---- -0--	<i>s lock_dyn_reg</i>	Lock dynamic registers <b>0 → Dynamic registers are not locked. Changes to dynamic registers are applied at the end of current frame</b> <b>1 → Dynamic registers are locked. All changes are memorized but are not taken into account. They are applied only when lock_dyn_reg is set to 0, at the end of the current frame.</b> Note: Depending on overlap_en (on same register), there might be a delay of 1 frame to apply changes to dynamic registers.
---- --0-	<i>s trig_pad_inv</i>	TRIG pin polarity <b>0 → TRIG pin is active high</b> <b>1 → TRIG pin is active low</b>
---- ---0	<i>s trig_pad_sel</i>	TRIG pin enable <b>0 → TRIG pin is disabled.</b> <b>1 → TRIG pin is enabled</b>
---- ---- 00--	<i>rs roi_flash_mode[7:6]</i>	ROI Flash Strobe mode selection <b>00 → Flash Strobe OFF: FLO = 0</b> <b>01 → Flash Strobe ON: FLO = 1 during integration time</b> <b>10 → Flash Strobe ON: FLO = 1 during integration time + readout</b> <b>11 → Flash Strobe ON: FLO = 1 during acquisition sequence</b>
---- ---- --00	<i>rs roi_readout_mode[5:4]</i>	ROI readout mode selection <b>00 → 5T Global Shutter</b> <b>01 → 4T + Global Reset</b> <b>10 → 4T + ERS</b> <b>11 → Reserved</b>

Default Value	Bitfield name	Description
----- 0---	<i>rs roi_video_en</i>	Video mode enable <b>0 → Video mode disabled</b> <b>1 → Acquisitions are done in video mode, with a constant frame period. See t_frame_period (@ h0C).</b>
----- -1--	<i>rs roi_overlap_en</i>	Overlap mode enable <b>0 → No overlap mode enabled</b> <b>1 → Acquisitions are done in overlap mode, not used if readout_mode = 4T+GR</b>
----- --0-	<i>s trig_rqst</i>	SPI trigger enable <b>0 → SPI trigger inactive.</b> <b>1 → SPI trigger calls for an acquisition</b>
----- ---1	<i>s stdby_rqst</i>	STANDBY request <b>0 → The chip is exiting STANDBY state</b> <b>1 → The device will re-enter STANDBY state after the end of the frame that has started to integrate.</b> Note: This means that, if overlap_en = 1, then STANDBY state is entered only after the end of next frame.

**Caution:** This register is not a simple static (s) register; it contains some restricted static (rs) bitfields. Take care not to change any 'rs' bitfields (ex: overlap\_en), while changing an 's' bitfield (ex: [trig\\_rqst](#)), when the device is not in IDLE or STANDBY state.

## 17.3.9 Frame Period

<b>Name</b>	reg_t_frame_period
<b>Address</b>	h0C
<b>Type</b>	Dynamic
<b>Default</b>	h0000

Default Value	Bitfield name	Description
0000 0000 0000 0000	<i>t_frame_period[15:0]</i>	<p>Frame period length            Defines the frame period in number of lines            This frame period is used in video mode if video mode is enabled. See roi_video_en (@ h0B)  <b>Min = h0000</b> → not taken into account  <b>Max = hFFFE</b> → Frame period of 65534 lines = 1s if CLK_CTRL @57 MHz and line_length = h70</p>

## 17.3.10 Wait Time

<b>Name</b>	reg_t_wait
<b>Address</b>	h0D
<b>Type</b>	Dynamic
<b>Default</b>	h0000

Default Value	Bitfield name	Description
0000 0000      0000 0000	<i>t_wait[15:0]</i>	<p>ROI wait time</p> <p>Defines the wait time after the end of each read image, programmed in numbers of lines.</p> <p><b>MIN = h0000 → wait time = 0 line</b></p> <p><b>MAX = hFFF0 → d65520 lines = 1s if CLK_CTRL @57 MHz and line_length = h70</b></p> <p>Note:</p> <ol style="list-style-type: none"> <li>1. At the end of each ROI&lt;i&gt; cycle, this wait time is added with a specific roi&lt;i&gt;_t_wait_ext (@h10 /@h1D /...)</li> <li>2. Check error_time_overflow (@ h3E) to see if roi_t_wait is too long. See frame period calculation in <a href="#">Section 19.2.2</a> for details.</li> </ol>

17.3.11 ROI 1 Control

This group of registers defines all the ROI1 parameters

<b>Group Name</b>	reg_roi1*
<b>Group Address</b>	h0E to h1A
<b>Type</b>	Dynamic

Address (Hex)	Default Value (Hex)		Bitfield name	Description
h0E	h0200		<i>roi1_t_int_ll[15:0]</i>	<p>Integer part of ROI1 integration time                      Defines the integer part of the integration time in number of lines.                      Min = h0 → Integer part of integration time is null.  <b>Default = h200 → d512 lines = 8 ms</b> with CLK_CTRL @57 MHz and line_length = h70                      Max = hFFFE → d65534 lines = 1s</p> <p>Note: 1. This integration time is added to the fractional part <i>roi1_t_int_clk</i> (@ h0F)                      2. Check <i>error_time_overflow</i> (@ h3E) to see if this parameter is too big.                      See frame period calculation in <a href="#">Section 19.2.2</a> for details.</p>
h0F	h00	--	<i>roi1_rep_nb[7:0]</i>	<p>Number of ROI1 cycle repetitions                      Defines the number of ROI1 cycles that are read out = <i>roi1_rep_nb</i> + 1  <b>Min h00 → 1 ROI1 is read out.</b>                      Max hFF → 256 ROI1 are read out.</p>
	--	h00	<i>roi1_t_int_clk[7:0]</i>	<p>Fractional part of ROI1 integration time                      Defines the fractional part of the integration time in CLK_CTRL cycles x <i>t_int_clk_mult_factor</i> (@ h0A)  <b>Min= h00 → fractional part of integration time is null</b>                      Max= it is recommended to take <i>line_length_factor</i> as a maximum.</p> <p>Note: If <i>overlap_en</i> (@ h0B) = 1, then take care to check both <i>error_t_tint_big</i> and <i>error_t_tint_small</i> (@ h3E).</p>

Address (Hex)	Default Value (Hex)		Bitfield name	Description
h10	h0000		<i>roi1_t_wait_ext[10:0]</i>	ROI1 extended wait time Defines an additional wait time after the end of the ROI1 cycle (last repetition of ROI1), to be added to <i>t_wait</i> , in number of lines <b>Min= h000 → 0 line added</b> Max= h7FF → d2047 lines added on <i>twait</i> (~32 ms if CLK_CTRL @57 MHz and <i>line_length</i> = h70)
h11	h00	--	<i>roi1_ana_gain[2:0]</i>	Analog gain applied on ROI1 <b>h0 → x1</b> h1 → x1.5 h2 → x2 h3 → x3 h4 → x4 h5 → x6 h6 → x8 h7 → x8
	--	h00	<i>roi1_dig_gain[7:0]</i>	Global digital gain applied on ROI1 <b>Min= h00 → x1</b> Max= hFF → x15.875
h12	h0006		<i>roi1_0l_1[10:0]</i>	1st line of 1st SIMR horizontal band Min = 0 <b>Default = h06</b> Max: [ <i>roi1_0l_1</i> + <i>roi1_h_1</i> ] < d1036
h13	h0400		<i>roi1_h_1[10:0]</i>	Height of 1st SIMR horizontal band Min = 1 <b>Default = h400 → d1024</b> Max: [ <i>roi1_0l_1</i> + <i>roi1_h_1</i> ] < d1036
h14	h0006		<i>roi1_0c_1[10:0]</i>	1st column of 1st SIMR vertical band Min = 0 <b>Default = h006</b> Max: [ <i>roi1_0c_1</i> + <i>roi1_w_1</i> ] < d1292
h15	h0500		<i>roi1_w_1[10:0]</i>	Width of 1st SIMR vertical band Min = 1 <b>Default h0500 → d1280 pixels</b> Max: [ <i>roi1_0c_1</i> + <i>roi1_w_1</i> ] < d1292
h16	h0000		<i>roi1_0l_2[10:0]</i>	1st line of 2nd SIMR horizontal band Min: [ <i>roi1_0l_1</i> + <i>roi1_h_1</i> ] < <i>roi1_0l_2</i> <b>Default = h00</b> Max: [ <i>roi1_0l_2</i> + <i>roi1_h_2</i> ] < d1036 Note: Used only if <i>roi1_h_2</i> (@ h17) > 0
h17	h0000		<i>roi1_h_2[10:0]</i>	Height of 2nd SIMR horizontal band <b>Min = 0 → no second horizontal band</b> Max : [ <i>roi1_0l_2</i> + <i>roi1_h_2</i> ] < d1036

Address (Hex)	Default Value (Hex)		Bitfield name	Description
h18	h0000		<i>roi1_0c_2[10:0]</i>	1st column of 2nd SIMR vertical band Min : $[roi1\_0c\_1 + roi1\_w\_1] < roi1\_0c\_2$ <b>Default = h00</b> Max: $[roi1\_0c\_2 + roi1\_w\_2] < d1292$ Note: Used only if $roi1\_w\_2$ (@ h19) > 0
h19	h0000		<i>roi1_w_2[10:0]</i>	Width of 2nd SIMR vertical band <b>Min 0 → no second vertical band</b> Max: $[roi1\_0c\_2 + roi1\_w\_2] < d1292$
h1A	h00	--	<i>roi1_subs_v[7:0]</i>	Vertical sub-sampling on ROI1 $= 8/(roi1\_subs\_v + 8)$ <b>Min h00 → sub-sampling factor 1/1</b> Max hFF → sub-sampling factor 1/32.875
	--	h00	<i>roi1_subs_h[7:0]</i>	Horizontal sub-sampling on ROI1 $= 8/(roi1\_subs\_h + 8)$ <b>Min h00 → sub-sampling factor 1/1</b> Max hFF → sub-sampling factor 1/32.875

## 17.3.12 ROI 2 Control

This group of registers defines all the ROI2 cycle parameters

<b>Group Name</b>	reg_roi2*
<b>Group Address</b>	h1B to h23
<b>Type</b>	Dynamic

Address (Hex)	Default Value (Hex)		Bitfield name	Description
h1B	h0200		<i>roi2_t_int_ll[15:0]</i>	<p>Integer part of ROI2 integration time Defines the integer part of the integration time in number of lines. Min = h0 → Integer part of integration time is null. <b>Default = h200 → d512 lines = 8 ms</b> with CLK_CTRL @57 MHz and line_length = h70 Max = hFFFE → d65534 lines = 1s Note:           <ol style="list-style-type: none"> <li>1. This integration time is added to the fractional part roi2_t_int_clk (@ h1C)</li> <li>2. Check error_time_overflow (@ h3E) to see if this parameter is too big. See frame period calculation in <a href="#">Section 19.2.2</a> for details.</li> </ol> </p>
h1C	h00	--	<i>roi2_rep_nb[7:0]</i>	<p>Number of ROI2 cycle repetitions Defines the number of ROI2 cycles that are read out = roi2_rep_nb +1 <b>Min h00 → 1 ROI2 is read out.</b> Max hFF → 256 ROI2 are read out.</p>
	--	h00	<i>roi2_t_int_clk[7:0]</i>	<p>Fractional part of ROI2 integration time Defines the fractional part of the integration time in CLK_CTRL cycles x t_int_clk_mult_factor (@ h0A) <b>Min= h00 → fractional part of integration time is null</b> Max= it is recommended to take line_length_factor as a maximum. Note: If overlap_en (@ h0B) = 1, then take care to check both error_t_tint_big and error_t_tint_small (@ h3E).</p>



Address (Hex)	Default Value (Hex)		Bitfield name	Description
h1D	h0000		<i>roi2_t_wait_ext[10:0]</i>	ROI2 extended wait time Defines an additional wait time after the end of the ROI2 cycle (last repetition of ROI2), to be added to <i>t_wait</i> , in number of lines <b>Min= h000 → 0 line added</b> Max= h7FF → d2047 lines added on <i>twait</i> (~ 32 ms if CLK_CTRL @57 MHz and <i>line_length</i> = h70)
h1E	h00	--	<i>roi2_ana_gain[2:0]</i>	Analog gain applied on ROI2 <b>h0 → x1</b> h1 → x1.5 h2 → x2 h3 → x3 h4 → x4 h5 → x6 h6 → x8 h7 → x8
	--	h00	<i>roi2_dig_gain[7:0]</i>	Global digital gain applied on ROI2 <b>Min= h00 → x1</b> Max= hFF → x15.875
h1F	h0006		<i>roi2_0l_1[10:0]</i>	1st line of ROI2 Min = 0 <b>Default = h06</b> Max: [ <i>roi2_0l_1</i> + <i>roi2_h_1</i> ] < d1036
h20	h0400		<i>roi2_h_1[10:0]</i>	Height of ROI2 Min = 1 <b>Default = h400 → d1024</b> Max: [ <i>roi2_0l_1</i> + <i>roi2_h_1</i> ] < d1036
h21	h0006		<i>roi2_0c_1[10:0]</i>	1st column of ROI2 Min = 0 <b>Default = h006</b> Max: [ <i>roi2_0c_1</i> + <i>roi2_w_1</i> ] < d1292
h22	h0500		<i>roi2_w_1[10:0]</i>	Width of ROI2 Min = 1 <b>Default h0500 → d1280 pixels</b> Max: [ <i>roi2_0c_1</i> + <i>roi2_w_1</i> ] < d1292
h23	h00	--	<i>roi2_subs_v[7:0]</i>	Vertical sub-sampling on ROI2 = 8/( <i>roi2_subs_v</i> + 8) <b>Min h00 → sub-sampling factor 1/1</b> Max hFF → sub-sampling factor 1/32.875
	--	h00	<i>roi2_subs_h[7:0]</i>	Horizontal sub-sampling on ROI2 = 8/( <i>roi2_subs_h</i> + 8) <b>Min h00 → sub-sampling factor 1/1</b> Max hFF → sub-sampling factor 1/32.875

## 17.3.13 ROI 3 Control

This group of registers defines all the ROI3 cycle parameters

<b>Group Name</b>	reg_roi3*
<b>Group Address</b>	h24 to h2C
<b>Type</b>	Dynamic

Address (Hex)	Default Value (Hex)		Bitfield name	Description
h24	h0200		<i>roi3_t_int_ll[15:0]</i>	<p>Integer part of ROI3 integration time Defines the integer part of the integration time in number of lines. Min = h0 → Integer part of integration time is null. <b>Default = h200 → d512 lines = 8 ms</b> with CLK_CTRL @57 MHz and line_length = h70 Max = hFFFE → d65534 lines = 1s</p> <p>Note: 1. This integration time is added to the fractional part <i>roi3_t_int_clk</i> (@ h25) 2. Check <i>error_time_overflow</i> (@ h3E) to see if this parameter is too big. See frame period calculation in <a href="#">Section 19.2.2</a> for details.</p>
h25	h00	--	<i>roi3_rep_nb[7:0]</i>	<p>Number of ROI3 cycle repetitions Defines the number of ROI3 cycles that are read out = <i>roi3_rep_nb</i> + 1 <b>Min h00 → 1 ROI3 is read out.</b> Max hFF → 256 ROI3 are read out.</p> <p>Note: Check <i>roi_max_id</i> (@ h0A) to see if this ROI cycle is run</p>
	--	h00	<i>roi3_t_int_clk[7:0]</i>	<p>Fractional part of ROI3 integration time Defines the fractional part of the integration time in CLK_CTRL cycles x <i>t_int_clk_mult_factor</i> (@ h0A) for ROI3 <b>Min= h00 → fractional part of integration time is null</b> Max= it is recommended to take <i>line_length_factor</i> as a maximum.</p> <p>Note: If <i>overlap_en</i> (@ h0B) = 1, then take care to check both <i>error_t_tint_big</i> and <i>error_t_tint_small</i> (@ h3E).</p>

Address (Hex)	Default Value (Hex)		Bitfield name	Description
h26	h0000		<i>roi3_t_wait_ext[10:0]</i>	ROI3 extended wait time Defines an additional wait time after the end of the ROI3 cycle (last repetition of ROI3), to be added to <i>t_wait</i> , in number of lines <b>Min= h000 → 0 line added</b> Max= h7FF → d2047 lines added on <i>twait</i> (~32 ms if CLK_CTRL @57 MHz and <i>line_length</i> = h70)
h27	h00	--	<i>roi3_ana_gain[2:0]</i>	Analog gain applied on ROI3 <b>h0 → x1</b> h1 → x1.5 h2 → x2 h3 → x3 h4 → x4 h5 → x6 h6 → x8 h7 → x8
	--	h00	<i>roi3_dig_gain[7:0]</i>	Global digital gain applied on ROI3 <b>Min= h00 → x1</b> Max= hFF → x15.875
h28	h0006		<i>roi3_0l_1[10:0]</i>	1st line of ROI3 Min = 0 <b>Default = h06</b> Max: [ <i>roi3_0l_1</i> + <i>roi3_h_1</i> ] < d1036
h29	h0400		<i>roi3_h_1[10:0]</i>	Height of ROI3 Min = 1 <b>Default = h400 → d1024</b> Max: [ <i>roi3_0l_1</i> + <i>roi3_h_1</i> ] < d1036
h2A	h0006		<i>roi3_0c_1[10:0]</i>	1st column of ROI3 Min = 0 <b>Default = h006</b> Max: [ <i>roi3_0c_1</i> + <i>roi3_w_1</i> ] < d1292
h2B	h0500		<i>roi3_w_1[10:0]</i>	Width of ROI3 Min = 1 <b>Default h0500 → d1280 pixels</b> Max: [ <i>roi3_0c_1</i> + <i>roi3_w_1</i> ] < d1292
h2C	h00	--	<i>roi3_subs_v[7:0]</i>	Vertical sub-sampling on ROI3 = 8/( <i>roi3_subs_v</i> + 8) <b>Min h00 → sub-sampling factor 1/1</b> Max hFF → sub-sampling factor 1/32.875
	--	h00	<i>roi3_subs_h[7:0]</i>	Horizontal sub-sampling on ROI3 = 8/( <i>roi3_subs_h</i> + 8) <b>Min h00 → sub-sampling factor 1/1</b> Max hFF → sub-sampling factor 1/32.875

## 17.3.14 ROI 4 Control

This group of registers defines all the ROI4 cycle parameters.

<b>Group Name</b>	reg_roi4*
<b>Group Address</b>	h2D to h35
<b>Type</b>	Dynamic

Address (Hex)	Default Value (Hex)		Bitfield name	Description
h2D	h0200		<i>roi4_t_int_ll[15:0]</i>	<p>Integer part of ROI4 integration time Defines the integer part of the integration time in number of lines. Min = h0 → Integer part of integration time is null. <b>Default = h200 → d512 lines = 8 ms</b> with CLK_CTRL @57 MHz and line_length = h70 Max = hFFFE → d65534 lines = 1s</p> <p>Note: 1. This integration time is added to the fractional part <i>roi4_t_int_clk</i> (@ h2E) 2. Check <i>error_time_overflow</i> (@ h3E) to see if this parameter is too big. See frame period calculation in <a href="#">Section 19.2.2</a> for details.</p>
h2E	h00	--	<i>roi4_rep_nb[7:0]</i>	<p>Number of ROI4 cycle repetitions Defines the number of ROI4 cycles that are read out = <i>roi4_rep_nb</i> + 1 <b>Min h00 → 1 ROI4 is read out.</b> Max hFF → 256 ROI4 are read out.</p>
	--	h00	<i>roi4_t_int_clk[7:0]</i>	<p>Fractional part of ROI4 integration time Defines the fractional part of the integration time in CLK_CTRL cycles x <i>t_int_clk_mult_factor</i> (@ h0A) for ROI4 <b>Min= h00 → fractional part of integration time is null</b> Max= it is recommended to take <i>line_length</i> / <i>t_int_clk_mult_factor</i> as a maximum. Note: If <i>overlap_en</i> (@ h0B) = 1, then take care to check both <i>error_t_tint_big</i> and <i>error_t_tint_small</i> (@ h3E).</p>

Address (Hex)	Default Value (Hex)		Bitfield name	Description
h2F	h0000		<i>roi4_t_wait_ext[10:0]</i>	ROI4 extended wait time Defines an additional wait time after the end of the ROI4 cycle (last repetition of ROI4), to be added to <i>t_wait</i> , in number of lines <b>Min= h000 → 0 line added</b> Max= h7FF → d2047 lines added on <i>twait</i> (~32 ms if CLK_CTRL @57 MHz and <i>line_length</i> = h70)
h30	h00	--	<i>roi4_ana_gain[2:0]</i>	Analog gain applied on ROI4 <b>h0 → x1</b> h1 → x1.5 h2 → x2 h3 → x3 h4 → x4 h5 → x6 h6 → x8 h7 → x8
	--	h00	<i>roi4_dig_gain[7:0]</i>	Global digital gain applied on ROI4 <b>Min= h00 → x1</b> Max= hFF → x15.875
h31	h0006		<i>roi4_0l_1[10:0]</i>	1st line of ROI4 Min = 0 <b>Default = h06</b> Max: [ <i>roi4_0l_1</i> + <i>roi4_h_1</i> ] < d1036
h32	h0400		<i>roi4_h_1[10:0]</i>	Height of ROI4 Min = 1 <b>Default = h400 → d1024</b> Max: [ <i>roi4_0l_1</i> + <i>roi4_h_1</i> ] < d1036
h33	h0006		<i>roi4_0c_1[10:0]</i>	1st column of ROI4 Min = 0 <b>Default = h006</b> Max: [ <i>roi4_0c_1</i> + <i>roi4_w_1</i> ] < d1292
h34	h0500		<i>roi4_w_1[10:0]</i>	Width of ROI4 Min = 1 <b>Default h0500 → d1280 pixels</b> Max: [ <i>roi4_0c_1</i> + <i>roi4_w_1</i> ] < d1292
h35	h00	--	<i>roi4_subs_v[7:0]</i>	Vertical sub-sampling on ROI4 = 8/( <i>roi4_subs_v</i> + 8) <b>Min h00 → sub-sampling factor 1/1</b> Max hFF → sub-sampling factor 1/32.875
	--	h00	<i>roi4_subs_h[7:0]</i>	Horizontal sub-sampling on ROI4 = 8/( <i>roi4_subs_h</i> + 8) <b>Min h00 → sub-sampling factor 1/1</b> Max hFF → sub-sampling factor 1/32.875

## 17.3.15 Green Blue and Green Red Gain Control

<b>Name</b>	reg_dig_gain_gb_gr
<b>Address</b>	h36
<b>Type</b>	Dynamic
<b>Default</b>	h8080

Default Value	Bitfield name	Description
1000 0000    ---- ----	<i>gb_dig_gain[7:0]</i>	Green blue digital gain in color version Min = h00 → x0.25 <b>Default = h80 → x1</b> Max = hFF → x3.97 Note: Used only if color_en (@ h07)= 1
---- ----    1000 0000	<i>gr_dig_gain[7:0]</i>	Green red digital gain in color version Min = h00 → x0.25 <b>Default = h80 → x1</b> Max = hFF → x3.97 Note: Used only if color_en (@ h07)= 1

## 17.3.16 Blue and Red Gain Control

<b>Name</b>	reg_dig_gain_b_r
<b>Address</b>	h37
<b>Type</b>	Dynamic
<b>Default</b>	h8080

Default Value	Bitfield name	Description
1000 0000    ---- ----	<i>b_dig_gain[7:0]</i>	Blue digital gain Defines the blue digital gain in color version, and general digital gain in B&W version. Min = h00 → x0.25 <b>Default = h80 → x1</b> Max = hFF → x3.97 Note: This parameter is be used whatever the value of color_en (@ h07)
---- ----    1000 0000	<i>r_dig_gain[7:0]</i>	Red digital gain in color version Min = h00 → x0.25 <b>Default = h80 → 1</b> Max = hFF → x3.97 Note: This parameter is used only if color_en (@ h07)= 1

## 17.3.17 Clamp &amp; Offset Adjustments

<b>Name</b>	reg_clamp_offset
<b>Address</b>	h38
<b>Type</b>	Dynamic
<b>Default</b>	h0080

Default Value	Bitfield name	Description
0000 0000    ---- ----	<i>clamp_add_offset[7:0]</i>	Additional clamp offset Defines a signed additional (2's-complement) offset in LSB: Min = h80 → -128 hFF → -1 <b>Default = h00 → 0</b> h01 → 1 Max = h7F → 127 Note: Used only if clamp_auto_en (@ h07)= 1
---- ----    0000 0000	<i>clamp_manual_offset[7:0]</i>	Manual clamp offset Applied offset in LSB if clamp_auto_en (@ h07)= '0' <b>Min = h00 → 0</b> Max = hFF → 255



## 17.3.18 Clamp Configuration

<b>Name</b>	reg_clamp_cfg
<b>Address</b>	h39
<b>Type</b>	Restricted static
<b>Default</b>	h3880

Default Value	Bitfield name	Description
-011 ---- - - - -	<i>init_line_nb[2:0]</i>	Number of init lines Number of init lines (V0) before reading matrix Min = h0 <b>Default = h3 → 3 init lines</b> Max = h7
---- 1000 - - - -	<i>clamp_lock_th[3:0]</i>	Clamp lock mechanism threshold Defines the threshold for the lock mechanism (0 to 15 LSB) : Min = h0 <b>Default = h8 → 8 LSB threshold</b> Max = hF
---- ---- 1 - - -	<i>clamp_lock_en</i>	Clamp lock mechanism enable 0 → Disables lock mechanism <b>1 → Enables lock mechanism during automatic black level adjustment</b>
---- ---- -0 - -	<i>dig_cor_en</i>	Digital correction enable <b>0 → Digital correction is not allowed</b> 1 → Allows digital correction
---- ---- --00 0000	<i>v0_gain[5:0]</i>	Clamp digital V0 correction enable <b>Min = h00 → Bypass V0 correction</b> h01 → Apply a V0 ratio 1/64 Max = h3F → Apply a V0 ratio 63/64

## 17.3.19 Oscillator Programming

<b>Name</b>	reg_prg_osc
<b>Address</b>	h3A
<b>Type</b>	Restricted static
<b>Default</b>	h80C0

Default Value	Bitfield name	Description
1000 000-    ---- ----	<i>prg_osc_vsatsat_adjust[6:0]</i>	Adjust the ADC saturation to leave room for the clamp dark signal compensation. Min = h00 -> nominal value - 64% <b>Default = h40 → nominal value of Vsatsat ADC = 850 mV (see Rext calculation)</b> Max = h7F -> nominal value + 64%
---- ---0    1--- ----	<i>prg_osc_vsatsat_select[1:0]</i>	Reserved, must be kept at 01
---- ----    -100 0000	<i>prg_osc_freq_adjust[6:0]</i>	Allows adjustment of internal oscillator frequency at 114 MHz. Min = h00 <b>Default = h40 → default value given by R<sub>EXT</sub> for a given sensor</b> Max = h7F

**Note:** The oscillator is activated only if selected as clock source by `clk_on_adc_domain` or `clk_on_chain_domain` (@ h08, or if calibration is requested (see `calib_count_ref` @ h3B).

## 17.3.20 Calibration Count for Oscillator Calibration

<b>Name</b>	reg_calib_count_ref
<b>Address</b>	h3B
<b>Type</b>	Restricted static
<b>Default</b>	h0000

Default Value	Bitfield name	Description
0000 0000 0000 0000	<i>calib_count_ref[15:0]</i>	<p>Oscillator calibration reference count This register has two different uses:</p> <ul style="list-style-type: none"> <li>It sets the number of CLK_REF clock cycles to count for oscillator calibration: Min = h0001 → 1 clock cycle for calibration phase Max = hFFFF → 65535 clock cycles.</li> </ul> <p>Note:</p> <ol style="list-style-type: none"> <li>This parameter must not be too big, because fb_calib_count_osc (@ h3C) could overflow, depending on both frequency and ratio...</li> <li>This is NOT the number of clock cycles of the whole calibration sequence, you have to add the wake up phase for the oscillator (see t_wakeup_osc @ h43) and a few extra cycles.</li> </ol> <ul style="list-style-type: none"> <li>Writing into this register starts a calibration. You can check the calibration progress in calib_mbx (@ h02), and retrieve the result in fb_calib_osc_count (@ h3C)</li> </ul>

## 17.3.21 Oscillator Calibration Feedback

<b>Name</b>	fb_calib_osc_count
<b>Address</b>	h3C
<b>Type</b>	Feedback

Bit positions	Bitfield name	Description
XXXX XXXX    XXXX XXXX	<i>fb_calib_count_osc[15:0]</i>	Oscillator calibration result The calibration result is given as the number of CLK_OSC clock cycles counted.

## 17.3.22 Clamp Feedback

<b>Name</b>	fb_clamp
<b>Address</b>	h3D
<b>Type</b>	Feedback

Bit positions	Bitfield name	Description
XXXX XXXX    ---- ----	<i>fb_ana_offset[7:0]</i>	Analog offset Offset applied on ADC column in LSB (0 to 255) (no dynamic loss)
---- ----    XXXX XXXX	<i>fb_dig_offset[7:0]</i>	Digital offset Digital offset applied on pixel value after ADC conversion in LSB (0 to 255)

## 17.3.23 Sensor Status Feedback

<b>Name</b>	fb_status
<b>Address</b>	h3E
<b>Type</b>	Feedback

Bit positions	Bitfield name	Description
0000 000X    ---- ----	<i>flag_dig_cor</i>	Digital Correction flag 0 → Offset correction is done entirely in analog 1 → Digital correction has been performed
0000 000-    XX-- ----	<i>fb_state_main_global[1:0]</i>	Main global device state 00 → Device is in STANDBY 01 → Device is in WAKEUP (going to IDLE) 10 → Device is in IDLE (waiting for new trig) 11 → Device is in ACQUISITION
0000 000-    --X- ----	<i>error_time_overflow</i>	Timing configuration overflow error 0 → OK 1 → Computed frame period is greater than hFFFE
0000 000-    ---X ----	<i>error_corrupted_video</i>	Corrupted video error An error occurred on the applied frame_period: 0 → OK 1 → Computed frame period is greater than configured t_frame_period (@ h0C), in video mode.
0000 000-    ---- X---	<i>error_ll_vs_xfer</i>	Line length error reading pixels 0 → OK 1 → The programmed line_length (@ h04) is too small, and pixels are still being read into matrix at end of line

Bit positions	Bitfield name	Description
----- -X--	<i>error_ll_vs_conv</i>	Line length error during conversion 0 → OK 1 → The programmed line_length (@ h04) is too small, and conversion is still running at end of line
----- --X-	<i>error_t_int_big</i>	Integration time error on next image An integration time error of max 1.5 μs occurred. 0 → OK 1 → An error has been detected on the fractional part of the NEXT image integration time (the biggest one if we are in high dynamic configuration)
----- ---X	<i>error_t_int_small</i>	Integration time error on current image An integration time error of max 1.5 μs occurred. 0 → OK 1 → An error has been detected on the fractional part of the CURRENT image integration time (the smallest one if we are in high dynamic configuration)

### 17.3.24 Chip ID

Name	chip_id
Address	h7F
Type	Feedback
Default	h0800

Default Value	Bitfield Name	Description
0000 8000	chip_id[15:0]	h0800 → Sapphires 1.3M first version

### 17.3.25 DATA\_CLK activity

Name	DATA_CLK activity
Address	h44
Type	Restricted Static

Default value	Bitfield name	Description
--1- ---- - - - -	<i>clk_out_low_pwr</i>	Defines DATA_CLK activity: 0 → DATA_CLK always active except in STANDBY state 1 → DATA_CLK is active during the whole acquisition (integration, transmission and wait)

### 17.3.26 Pixtime Read Width

<b>Name</b>	pixtime_read_width
<b>Address</b>	h49
<b>Type</b>	Restricted Static
<b>Default</b>	h7B71

Default value	Bitfield name	Description
0111 1011 - - - -	<i>pixtime_read_5t_width[7:0]</i>	Pixel timing duration in 5T mode, step is CLK_CTRL period x 2 <b>Default = 123 clocks = 4.31 μs @57MHz</b>
- - - - - 0111 0001	<i>pixtime_read_4t_width[7:0]</i>	Pixel timing duration in 4T mode, step is CLK_CTRL period x 2 <b>Default = 113 clocks = 3.96 μs @57MHz</b>

## 17.4 SPI Timing

EB76C560 SPI requires CPOL = 0 and CPHA = 0.

First the SPI interface of the EV76C560 has to receive the first bit from the master on the on MOSI line which indicates if it is a read or write command. This first bit is followed by 7 bits giving the d1 to d127 addresses.

In a write sequence (see [Figure 17-1: One register write sequence](#)) first bit must be at high level. After having sent the 7 address bit - MSB first - the data are sent on the MOSI line (also MSB first).

**Figure 17-1.** One register write sequence

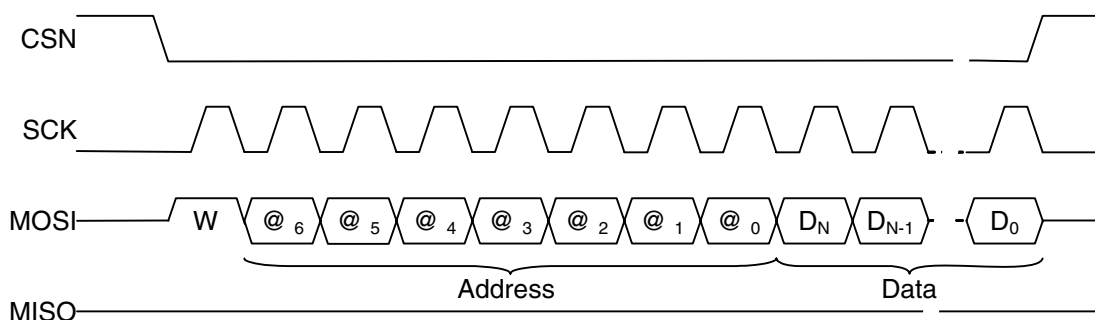

In a read sequence (see [Figure 17-2: One register read sequence](#)) first bit must be at low level. After having sent the 7 address bit MSB first, the data are read on the MISO line (also MSB first).

**Figure 17-2.** One register read sequence

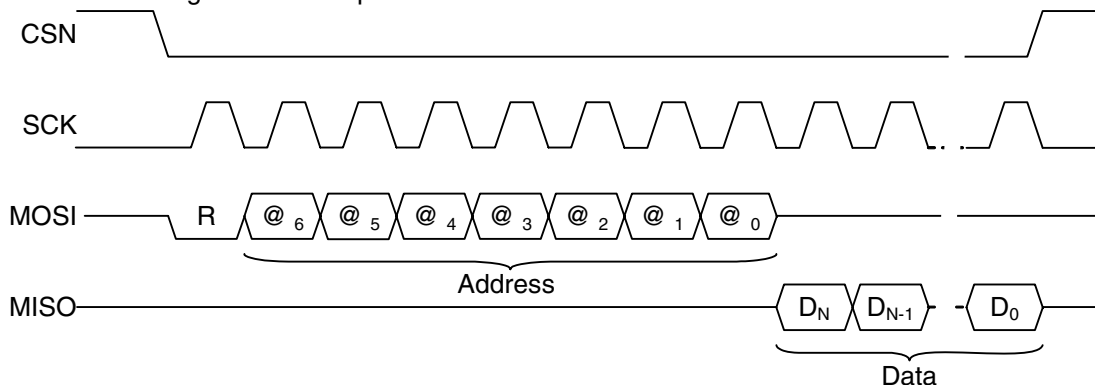

The master can also use a burst sequence (see [Figure 17-3: Burst sequence](#)) to read or write several adjacent registers.

The end of burst sequence occurs when the CSN Chip Select line is put back into inactive state at high level.

In burst mode the internal address is automatically incremented at the end of each data read/write phase.



For example, to read three 16-bit registers starting at address h10:

**Figure 17-3.** Burst sequence

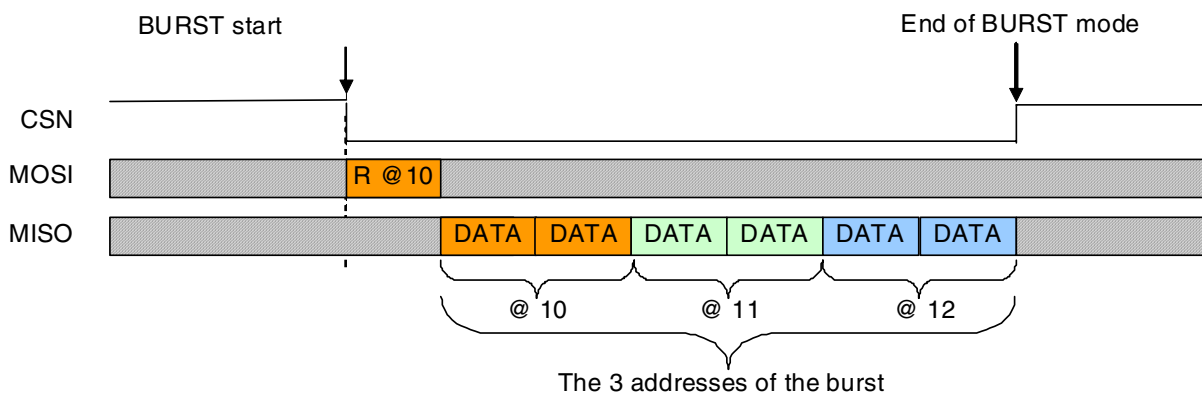

**Figure 17-4.** SPI timing specification

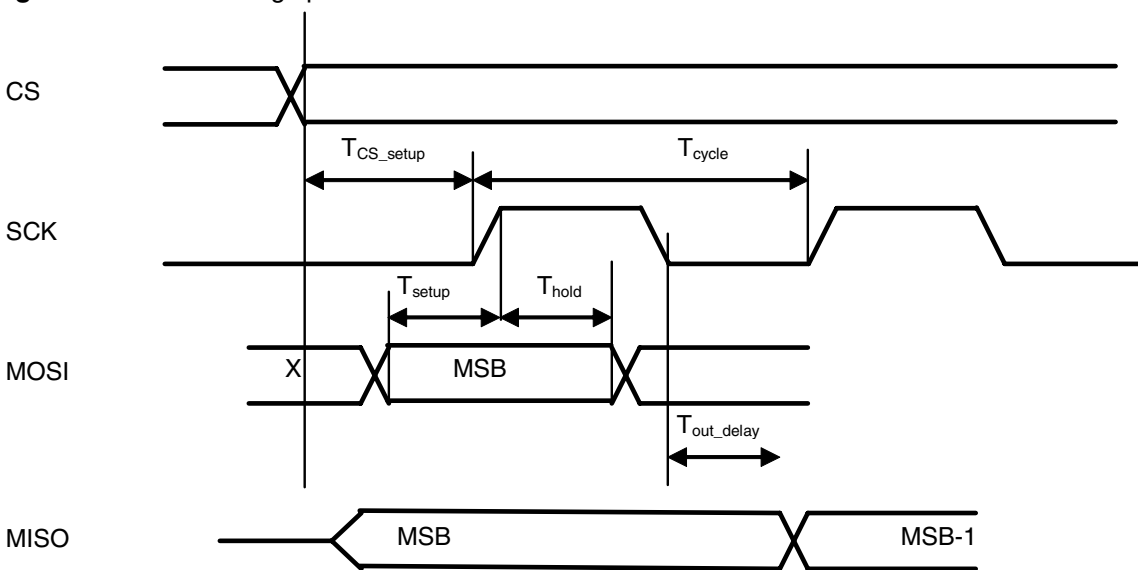

These timings depend on the process, current load, and post layout. The values given here should be considered only as general guidelines.

**Table 17-3.** SPI timing specification

Symbol	Typ
Tcycle	50 ns
Tsetup	<10 ns
Thold	<10 ns
Tcs_setup	>5 ns
Tout_delay	<20 ns depending on the current load

## 18. Sensor States

### 18.1 Static States

At startup, the sensor state is controlled by internal registers and by the RESETN and TRIG external signals. The registers are in a known state after a device reset. The RESETN must be pulled up and the TRIG signal can toggle.

The sensor state is indicated in the internal status registers and from the FLO external signal.

#### 18.1.1 Power-On Sequence

The following timing diagram shows the power up sequence initiated by a rising edge on 3.3 V and 1.8 V power supplies.

**Figure 18-1.** Power up sequence

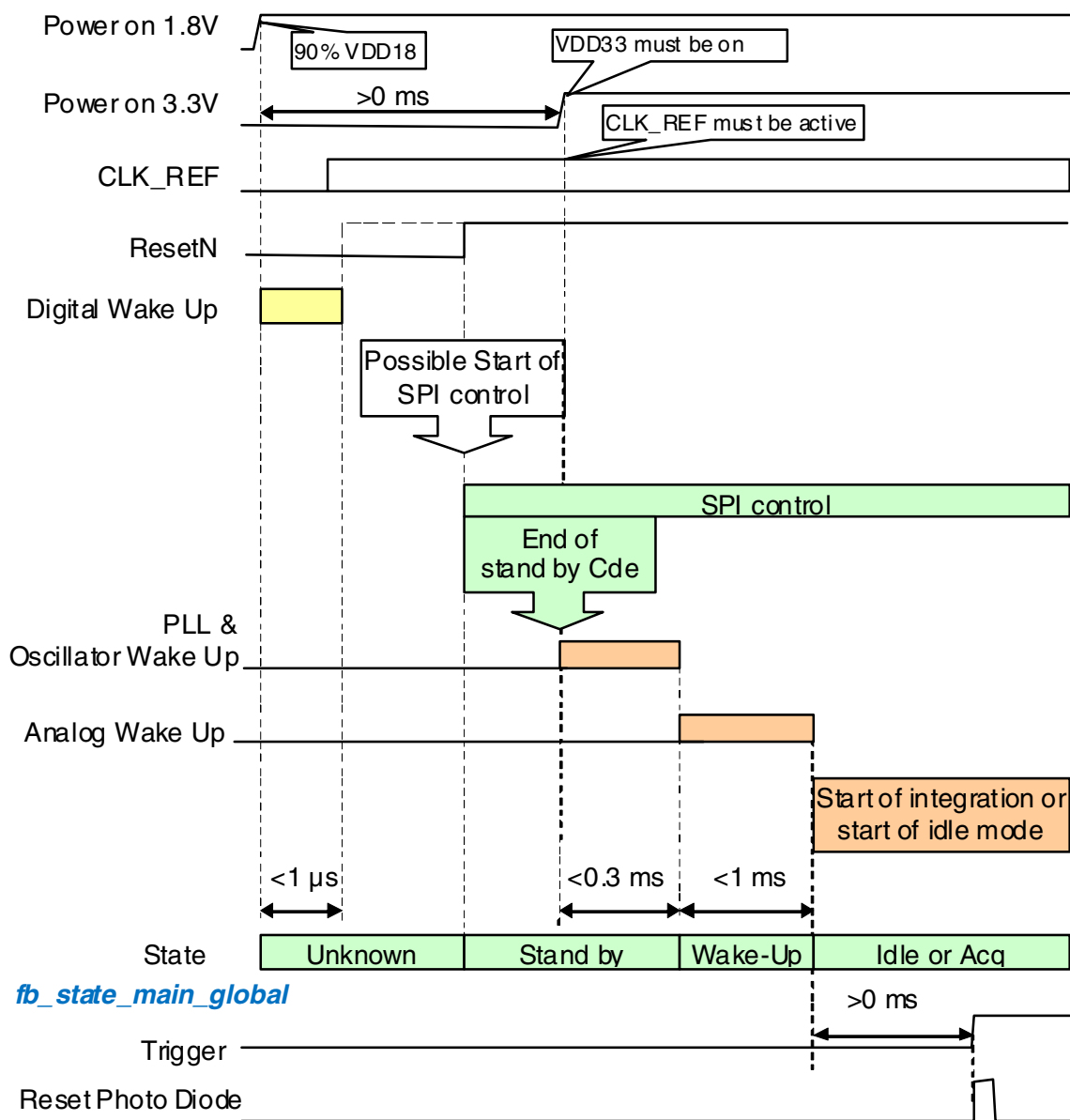

### 18.1.2 STANDBY

This is the lowest power consumption mode.

At power-up the sensor is in STANDBY state.

During STANDBY state the SPI registers may be read or written.

Transition from this state to IDLE state or beginning of integration has duration of less than 1 ms and is under SPI control with *stdby\_rqst* in *<reg\_ctrl\_cfg>* see [Section 17.3.8](#)

### 18.1.3 IDLE

In IDLE state, the device is "ready to start".

During IDLE state, SPI registers can be read or written.

The sensor can start integration from this state in less than 10  $\mu$ s, with an SPI command *trig\_rqst* in *<reg\_ctrl\_cfg>* or with a hardware trigger on the TRIG pin if enabled by *trig\_pad\_sel* in *<reg\_ctrl\_cfg>* see [Section 17.3.8](#)

Transition from this state to STANDBY state is under SPI control with *stdby\_rqst* in *<reg\_ctrl\_cfg>* see [Section 17.3.8](#)

## 18.2 Active States

Active state defines a state of the sensor during which it runs in integration or readout or is waiting for the end of an application task.

A typical acquisition sequence includes 3 states:

- Integration
- Readout
- Wait

When the sensor is waiting for a trigger it is put in IDLE state.

A short hardware or software trigger pulse starts the configured acquisition cycle. The example in [Figure 18-2](#) is for only 1 ROI with a repetition number of 1.

**Figure 18-2.** Acquisition sequence example 1

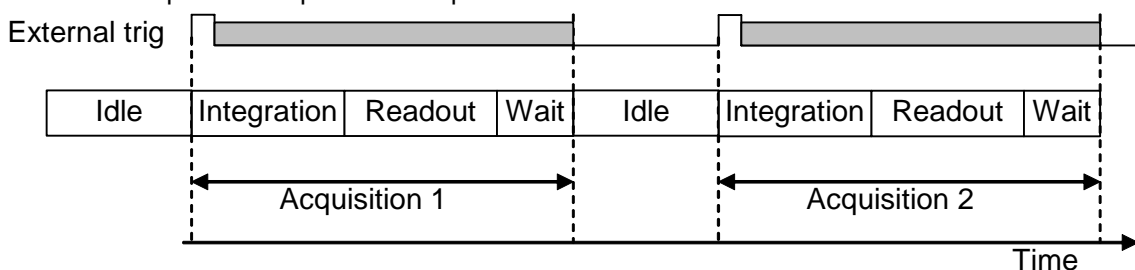

The example in [Figure 18-3](#) uses the cycle principle for 3 ROIs (*roi\_max\_id* = h2) (N1, N2 and N3 are configured by the *roi1\_rep\_nb*, *roi2\_rep\_nb* and *roi3\_rep\_nb* registers respectively). The Wait time ( $t_{WAIT}$ ) is defined in *<reg\_t\_wait>* and is added at the end of each acquisition.

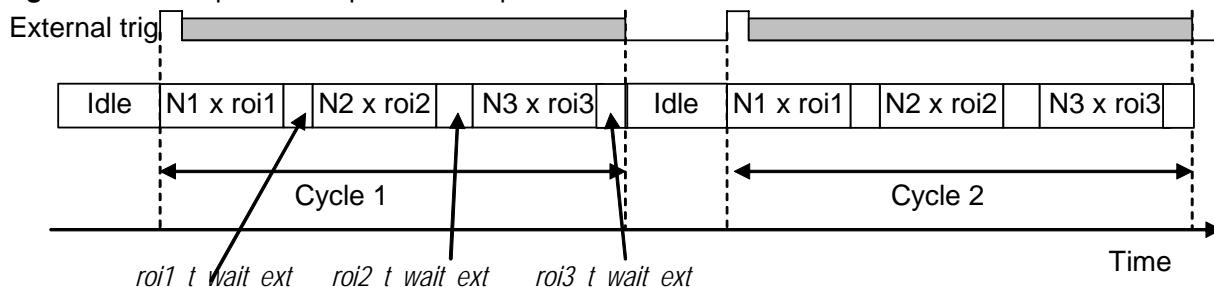
**Figure 18-3.** Acquisition sequence example 2

The example in [Figure 18-4](#) shows the behavior with the trig signal kept at high level

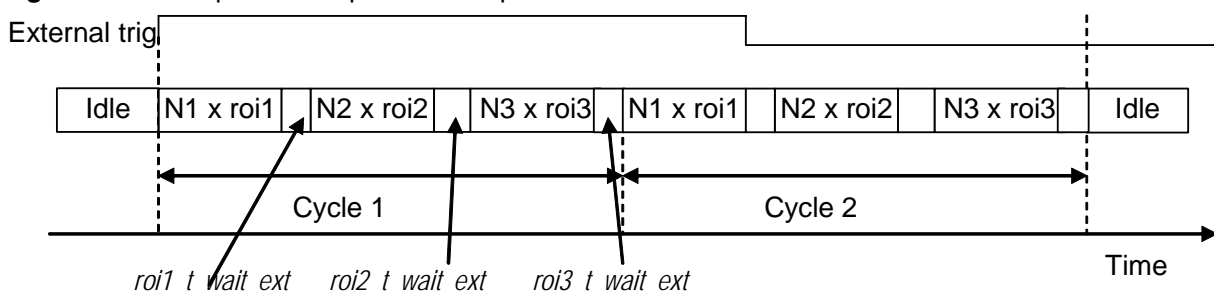
**Figure 18-4.** Acquisition sequence example 3**Notes:**

- The grey area indicates that any TRIG or trig\_rqst pulse during this period is not taken into account.
- If the *trig\_rqst* bit or the TRIG pin is deactivated during a cycle sequence, the sensor waits the end of the cycle before entering IDLE state.

The sensor provides three capture modes selectable by *roi\_readout\_mode* in `<reg_ctrl_cfg>` see [Section 17.3.8](#)

- Global Shutter *roi\_readout\_mode* = h0
- 4T + Global Reset *roi\_readout\_mode* = h1
- 4T + ERS *roi\_readout\_mode* = h2

With these 3 basic modes there are different possible operating sequences.

These are described in detail in the following paragraphs.

**18.2.1 Global Shutter Mode**

A GS acquisition sequence includes the following stages:

- Global reset of all photodiodes
- Integration simultaneously in all photodiodes
- Global transfer of all photodiode signals in sensing nodes
- Readout line by line
- Wait state

Figure 18-5. Global shutter

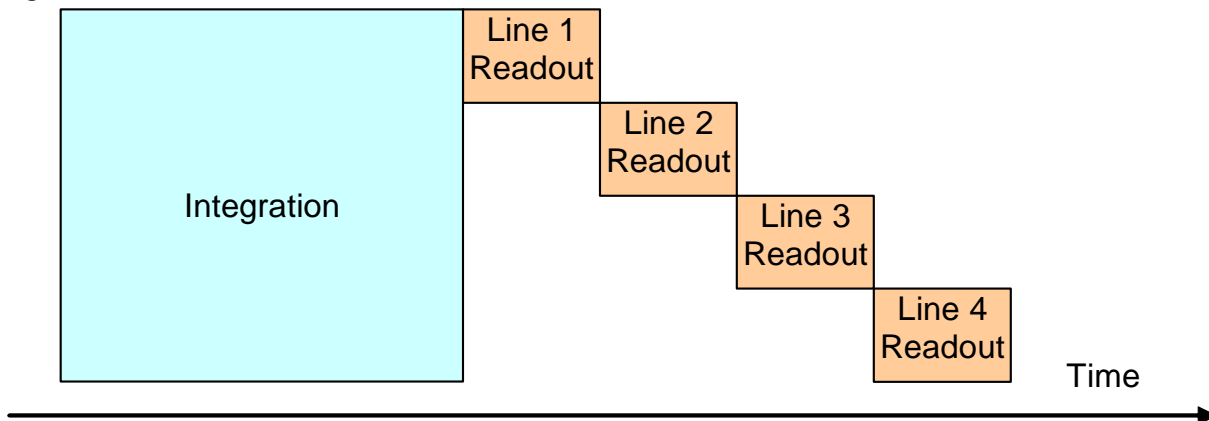
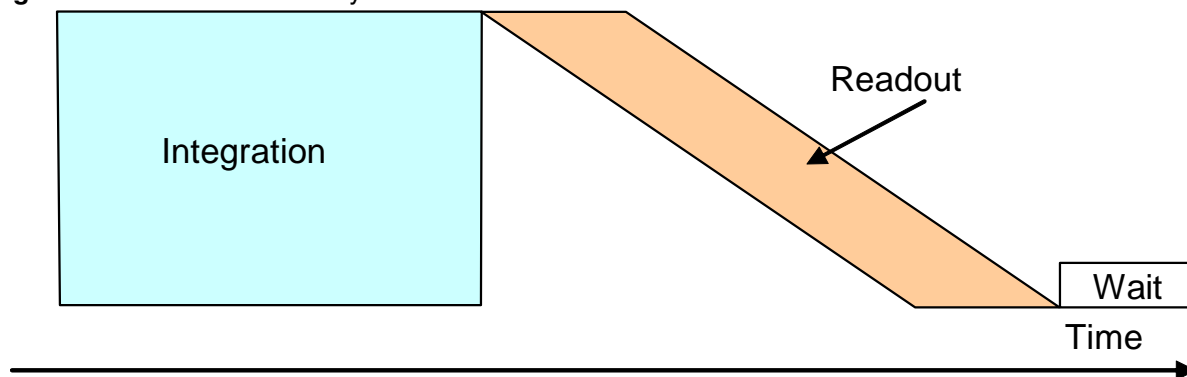

Figure 18-6. Global shutter symbolization



Using a 5T pixel, the global shutter mode does not allow a true CDS during pixel readout.

**18.2.2 ERS Mode**

Electronic Rolling Shutter (ERS) mode can perform true CDS timing that suppresses kTC (reset) noise. It offers better performance in terms of SNR and dynamic, but it is sensitive to the relative movement between camera and scene (called rolling shutter distortion).

In this mode every line has the same integration time duration but not at the same time. Refer to [Figure 18-7](#).

Figure 18-7. Rolling shutter principle

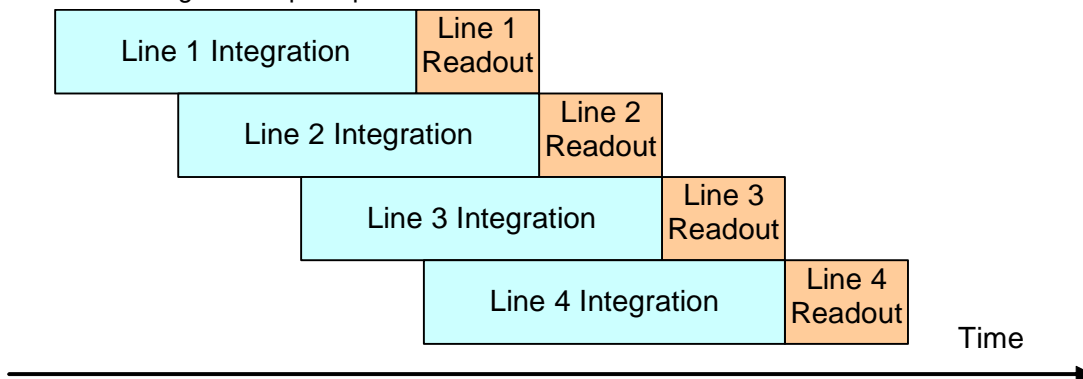

An ERS acquisition sequence includes the following states:

- Line by line integration state
- Line by line transfer and readout (this state starts at the end of the integration of the first line)
- Wait state

**Figure 18-8.** Rolling shutter symbolization

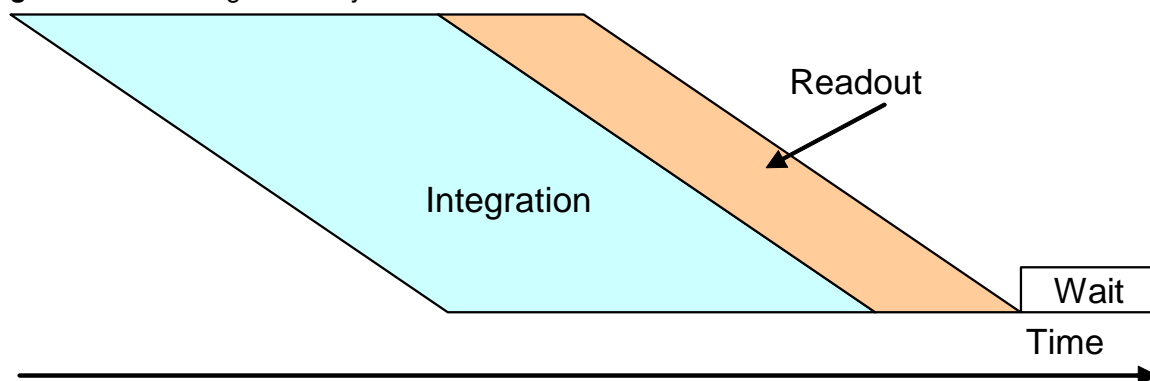

### 18.2.3 Overlap Option Definition

For ERS and GS modes, an overlap option is selectable by SPI. When it is selected the integration state of an image starts as soon as possible, before the end of the previous image.

[Figure 18-9](#) shows ERS mode where the integration is performed line by line

[Figure 18-10](#) shows GS mode where the integration is performed simultaneously in all photodiodes.

Twait is adjusted under SPI control.

Figure 18-9. Overlap / Non-overlap in ERS mode

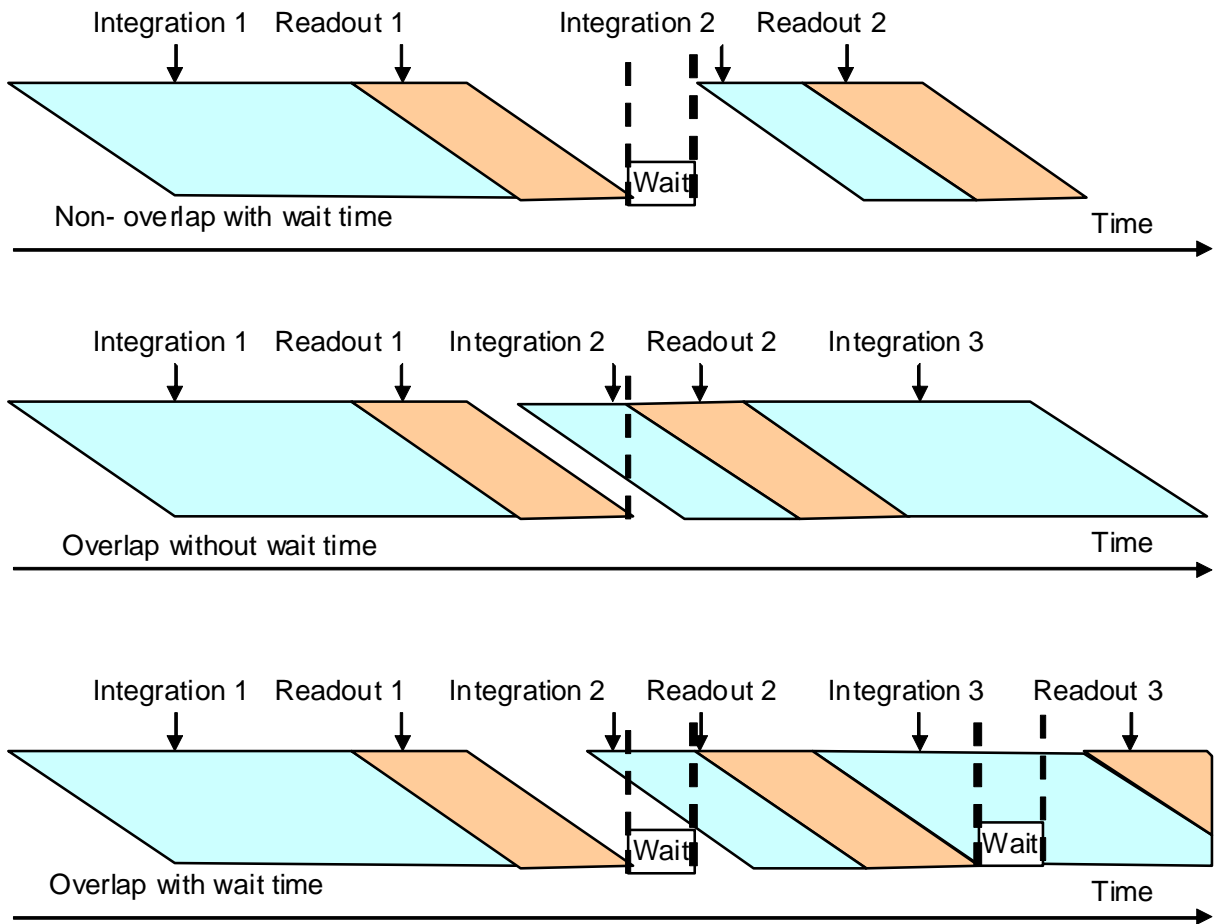

**Figure 18-10.** Overlap / Non-overlap in GS mode

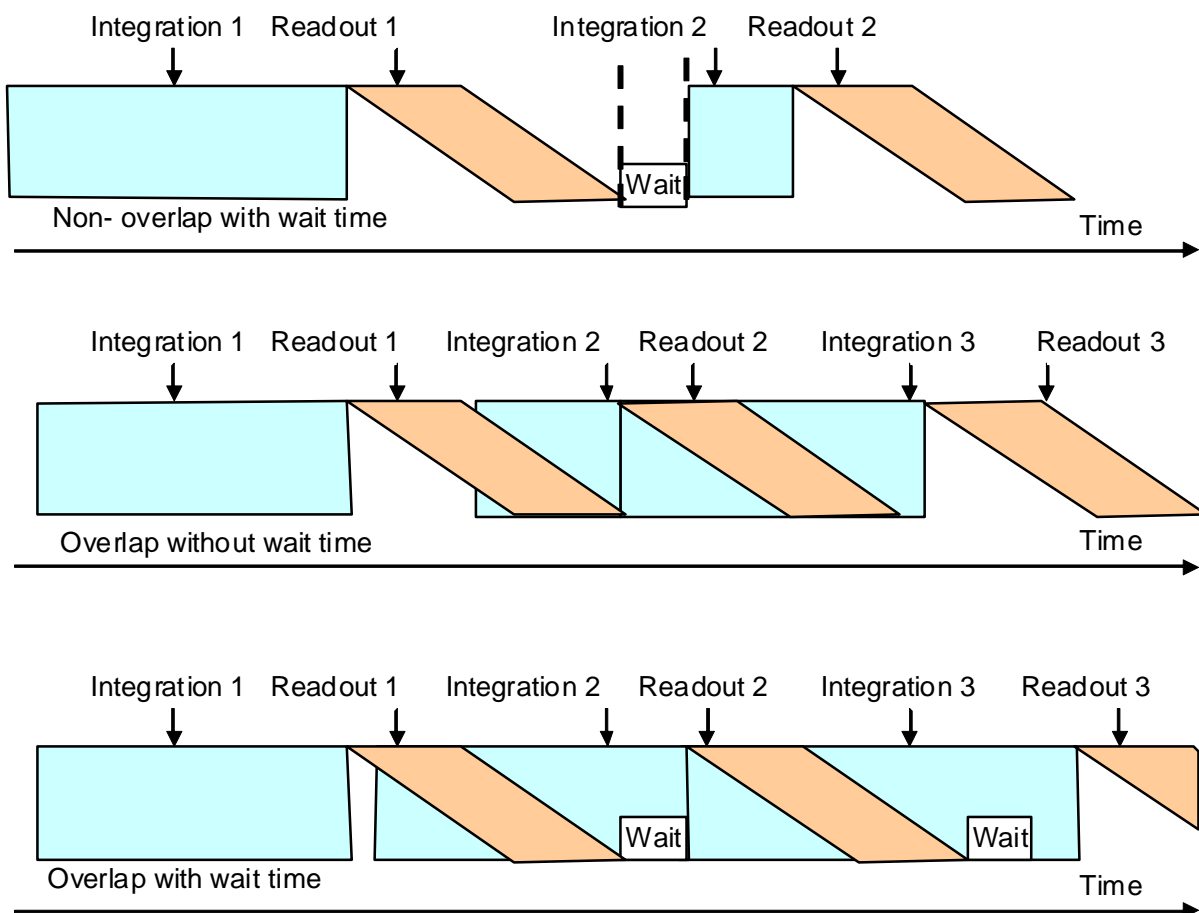

In these figures, the integration time is changed for each image to illustrate most of the different cases.

**18.2.4 ERS + GR Mode**

ERS + GR mode is a combination of ERS and GS modes. It allows the use of true CDS during pixel readout. It can be used for example if a synchronized light pulse is provided by the application. The moving effect may be negligible if the signal without light pulse is only negligibly different from the signal with light pulse.

The overlap option is not possible in ERS+GR mode.

**Figure 18-11.** ERS with Global Reset

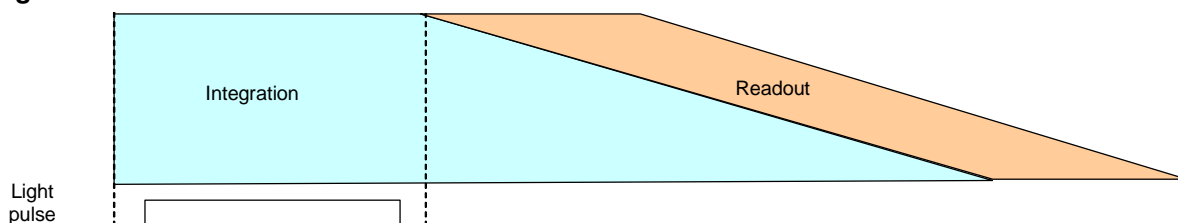



An ERS + GS acquisition sequence includes the following states:

- Global reset of all photodiodes and sensing nodes
- Integration stage
- Transfer, conversion and readout line by line (this state starts at the end of the integration of the first line)
- Wait stage

### 18.2.5 Video Option Definition

The Video Option can be defined for all capture modes. It is selected using the SPI. When it is selected the frame period is programmed by SPI and it constrains the integration time to a value less than the frame period.

The overlap option can be used with the video option.

Figure 18-12 gives a timing diagram showing the principle of the video option for GS readout mode with overlap option and 3 ROIs configured with only one repetition.

Figure 18-12. Video mode option

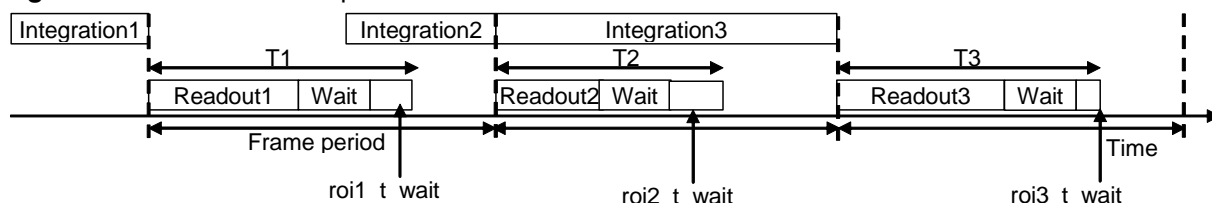

#### Notes:

- For each new frame, the device computes the minimum frame period value needed to correctly apply the integration time, the ROI readout and the wait time (in all frame and mode configurations). If the SPI frame period value is smaller than this minimum value, then the applied frame period is set to the computed value, and the `error_corrupted_video` bit is set to inform the user that the configured value is too small. The actually applied `frame_period` can be read in the header.

## 18.3 Interrupt Functions

### 18.3.1 Abort Function

This function allows the application to abort the current acquisition sequence. It has no effect if the sensor is in Standby or IDLE state.

The abort is taken into account:

- Immediately when the abort occurs during the integration or wait stage.
- At the end of the current line, when the abort occurs during the readout stage.

The abort sequence is cleared by writing any value in the `flag_abort_mbx` register.

When an abort occurs, all the register settings are preserved, so a new acquisition can be started immediately afterward. Depending on the used mode some artifacts may occur on the next image.

Figure 18-13. Abort timing

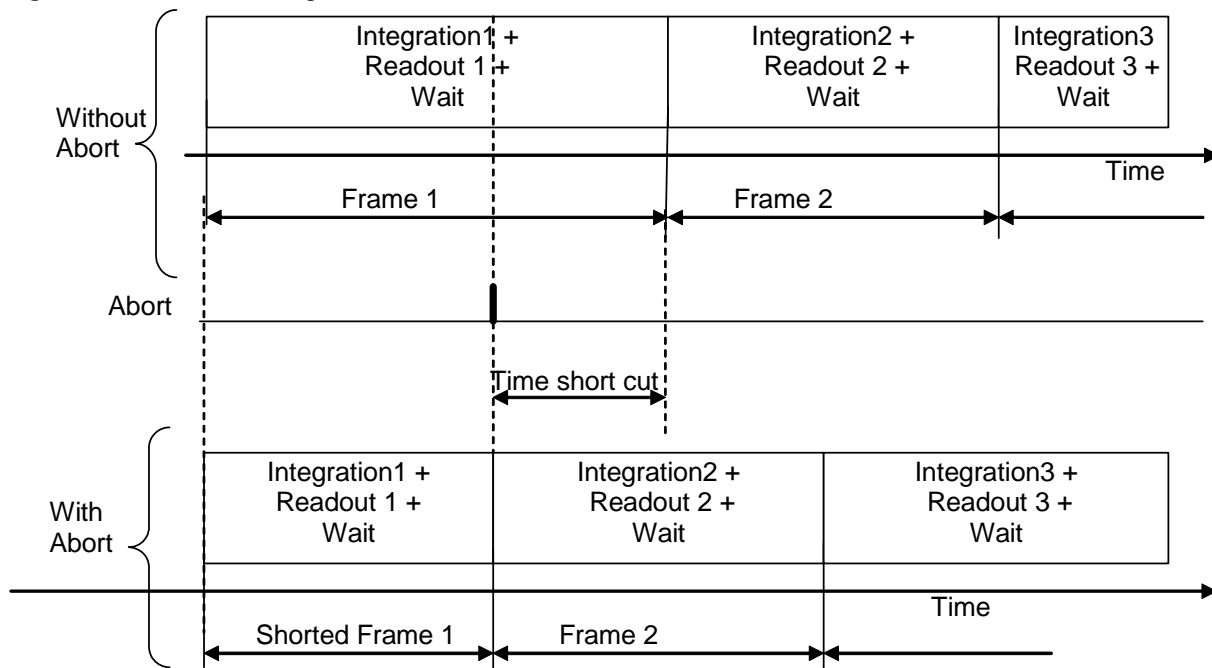

If an abort occurs during a MIMR sequence, then the sensor is ready to start the first integration of RO11.

### 18.3.2 Reset Function

The device can be reset either by:

- Writing or reading in *soft\_reset* see [Section 17.2.2](#).
- Applying a low pulse on the RESETN pin (minimum pulse duration is 20 ns).

After a reset, the device returns immediately to the factory default configuration. All registers to be configured with other values must be written again.

## 19. Synchronization Pulse and Timings

The FEN and LEN synchronization signals may be inverted by programming [sync\\_len\\_inv](#) and [sync\\_fen\\_inv](#) in [<reg\\_miscel2>](#). The DATA\_CLK may be inverted by using [clk\\_out\\_inv](#) in [<reg\\_miscel2>](#). See [Section 17.3.4](#)

### 19.1 Clock Limits

**Table 19-1.** Frequency limits

Parameter	Value			
	Min	Typ	Max	Unit
CLK_REF input for PLL	5	24	50	MHz
CLK_REF input for direct use	5		120	MHz
CLK_FIX input (if used)	5		120	MHz
Duty cycle on CLK_REF and CLK_FIX	40	50	60	%
DATA-CLK , CMOS output (to be able to reach 60 fps)	85	114	120	MHz
Duty cycle on DATA-CLK		50		%

## 19.2 Vertical Timings

### 19.2.1 Timing Diagram

Figure 19-1. Vertical timing graph

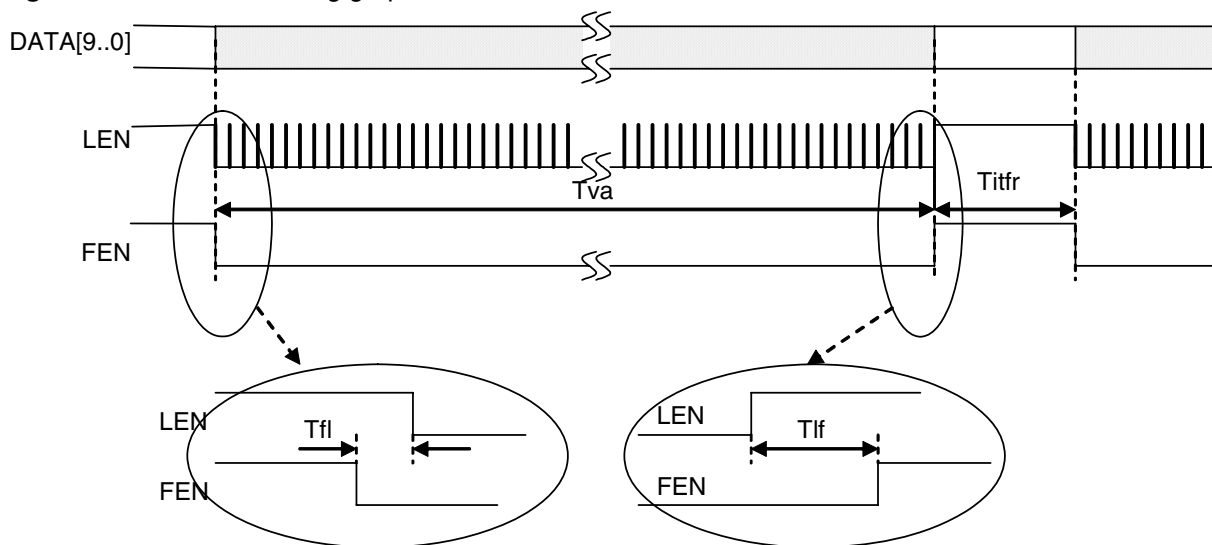

Table 19-2. Vertical timing specification

Parameter	Symbol	Nominal	Unit
Vertical valid data <sup>(1)</sup>	Tva	1024	Line period
FEN falling to LEN falling	Tfl	2 minimum	DATA_CLK
LEN rising to FEN rising	Tlf	2 minimum	DATA_CLK
Inter-frame time <sup>(2)</sup>	Titr	Configurable	Line period

1. Depends on ROI and Sub sampling:  $Tva = (roi\_height + 2 \text{ context\_en} + \text{histo\_en})$
2.  $Titr = t\_frame\_period - Tva$

## 19.2.2 Frame Period Calculation

The sensor runs properly in video mode if the frame period is currently programmed. The following paragraph gives the user a procedure to calculate the minimum frame period value to program (in number of lines) when `roi_video_en=1` (in register h0B).

If the frame period is not correct, two flags can warn the user:

- `error_corrupt_video` flag in the register h3E. A bad frame period will set this flag.
- `error_corrupt_overflow` flag in the register h3E: `reg_frame_period` exceeds 65534 (hFFFE) and this saturation value is applied.

**Table 19-3.** Registers used for frame period calculation

Entries	Register Address	Comments
<code>reg_t_frame_period</code>	h0C	
<code>roiN_t_int_ll</code>	h0E, h1B, h24, h2D	Depends on the ROI used
<code>extra_line_nb</code>	h04	Bits (12:15)
<code>init_line_nb</code>	h39	Bits (12:14)
<code>roi_expanded</code>	h07	Bit 8
<code>roiN_binning_en</code>	h0A	Bit 0,1,2 or 3
<code>t_wait</code>	h0D	
<code>roiN_t_wait_ext</code>	h10, h1D, h26, h2F	Depends on the ROI used
<code>roi_histo_en</code>	h0A	Bit 6
<code>roi_context_out_en</code>	h0A	Bit 7
<code>roi_overlap_en</code>	h0B	Bit 2
<code>Roi_height</code>		Calculated in <a href="#">Section 4.5.3.1</a>

For the Frame period computation (in number of lines), the user may follow the steps above:

1. Program the minimum number of extra-lines (register `extra_line_nb` @ h04)  

$$\text{extra\_line\_nb} = (2 \times \text{roiN\_binning\_en} + \text{roi\_histo\_en} + \text{roi\_context\_out\_en}) \times 2^{\text{roiN\_binning\_en}}$$
2. Readout time  

$$\text{Treadout} = 2 + \text{init\_line\_nb} + (6 \times \overline{\text{roi\_expanded}}) + \text{roi\_height} + \text{extra\_line\_nb} + 1$$

Minimum frame period

If `overlap_en = 0` then:

$$\text{reg\_t\_frame\_period} = \text{roiN\_t\_int\_ll} + \text{Treadout} + \text{t\_wait} + \text{roiN\_t\_wait\_ext} + \text{t\_flash\_on}$$

If `overlap_en = 1` then:

$$\text{reg\_t\_frame\_period} = \text{MAX}(\text{roiN\_t\_int\_ll} + 1 + \text{t\_flash\_on}; \text{Treadout} + \text{t\_wait} + \text{roiN\_t\_wait\_ext})$$

The result of the frame period calculation can be read from the context data, depending on the video mode:

- If `video_en=1`, and `reg_t_frame_period > t_frame_period_min`:  
then `Actual_frame_period = t_frame_period`,
- If `video_en=0`, then `Actual_frame_period = t_frame_period_min`

19.2.3 Typical Frame Rate

Table 19-4 gives the possible frame rates in overlap mode with a CLK\_ADC of 114 MHz.

In non-overlap mode, the integration time must be added to Tread.

Table 19-4. Frame rate example

Format	Number of columns	Number of lines	Line Length	T <sub>READ</sub> (ms)	Frame Rate in ERS Mode
1.3 MP	1280	1024	1792	16.4	60.9 fps
650 kP	1280	512	1792	8.4	119.6 fps
650 kP	640	1024	1792	16.4	60.9 fps

Using sub-sampling or windowing reduces the readout time only by the reduced number of lines.

19.3 Horizontal Timings

Figure 19-2. Horizontal timing graph

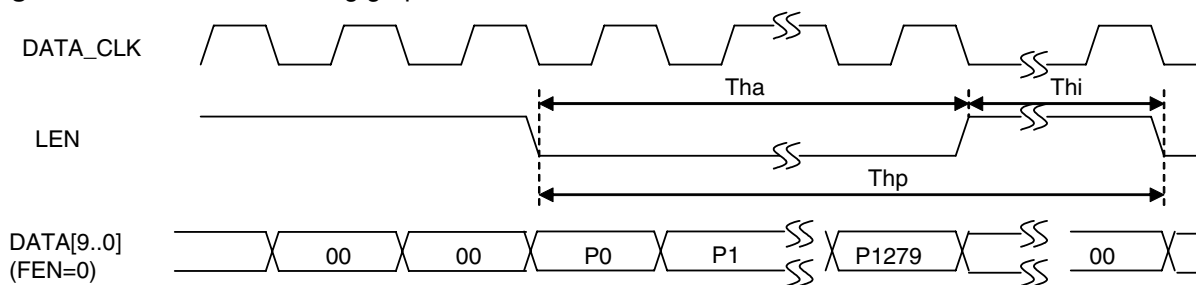

Table 19-5. Horizontal timing specification

Parameter	Symbol	Default ROI	Unit
Horizontal active pixel <sup>(1)</sup>	Tha	1280	DATA_CLK
Horizontal inactive pixel <sup>(2)</sup>	Thi	544	DATA_CLK
Horizontal period <sup>(2)</sup>	Thp	1792	DATA_CLK

1. Depends on ROI and Sub sampling.
2. Depends on line length configuration.

## 19.4 Line\_length Calculation

The sensor runs properly if the line length is currently programmed. The following paragraph gives the user a procedure to calculate the minimum line length value to program for correct sensor operation. Line length is calculated in number of CLK\_CTRL period.

If the line length is not correct, two flags can warn the user:

- The [error\\_ll\\_vs\\_conv](#) flag in the register h3E. A too long conversion time will set this flag.
- The [error\\_ll\\_vs\\_xfer](#) flag in the register h3E. A too long data readout time will set this flag.

The user must verify both to avoid any line length programming errors.

**Table 19-6.** Registers used for Line Length calculation

Entries	Register Address	Comments
CLK_CTRL (MHz)	-	See <a href="#">Section 14</a> .
CLK_ADC (MHz)	-	
CLK_CHAIN (MHz)	-	
<a href="#">Pixtime_read_5T_width</a>	h49	Range [0;255]
<a href="#">Pixtime_read_4T_width</a>	h49	Range [0;255]
<a href="#">Max_offset</a>	h06	Range [0;255]
<a href="#">Roi_width</a>		Calculated in <a href="#">Section 4.5.3</a>

The minimum line length value to be programmed in the SPI register (@ h04) is given by the following formula in decimal:

$$line\_length\ min = \frac{\max [line\_length\_conv, line\_length\_roi]}{8}$$

For a 4T pixel timing:

$$line\_length\_conv = 4 + 2 \times pixtime\_read\_4T\_width + \frac{(max\_offset + 2^{10} + 40) \times CLK\_CTRL}{CLK\_ADC}$$

$$line\_length\_roi = \frac{ROI\_width \times CLK\_CTRL}{CLK\_CHAIN} + \frac{40 \times CLK\_CTRL}{CLK\_ADC}$$

For a 5T pixel timing:

$$line\_length\_conv = 4 + 2 \times pixtime\_read\_5T\_width + \frac{(max\_offset + 2^{10} + 40) \times CLK\_CTRL}{CLK\_ADC}$$

$$line\_length\_roi = \frac{ROI\_width \times CLK\_CTRL}{CLK\_CHAIN} + \frac{40 \times CLK\_CTRL}{CLK\_ADC}$$

## 19.5 Pixel Timings

**Figure 19-3.** Data and sync timing diagram

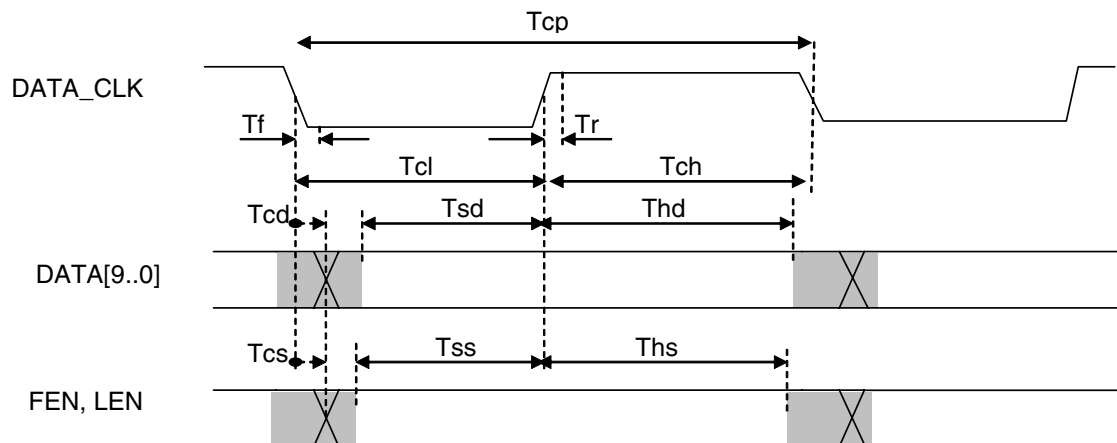

**Table 19-7.** Data and sync timing parameters

Parameter Definition	Symbol	Min	Typ	Max	Unit
Clock period	Tcp	8.33	8.77	200	ns
Clock low time <sup>(1)</sup>	Tcl	3.7			ns
Clock high time <sup>(1)</sup>	Tch	2			ns
DATA_CLK to data	Tcd	-0.9	-0.2	+0.7	ns
DATA_CLK to synch FEN or LEN	Tcs	-1.4	-0.6	+0.2	ns
Falling and rising edges on all signals with 10 pF load	Tr / Tf	0.8	1.5	2.6	ns

1. Including the clock input duty cycle 50 +/- 10% and frequency precision.  
 Setup times:  $T_{sd} = T_{cl} - T_{cd\ max} - Tr / T_{ss} = T_{cl} - T_{cs\ max} - Tr$   
 Hold times:  $T_{hd} = T_{ch} - T_{cd\ min} - Tr / T_{hs} = T_{ch} - T_{cs\ min} - Tr$

## 19.6 FLO (Flash Strobe Output)

This signal can be used to control the light source. Several SPI registers are used to define this signal.

This signal may be inverted [sync\\_flo\\_inv](#) in [<reg\\_miscel2>](#) see [Section 17.3.4](#) (in the timings FLO is shown non inverted)

The FLO control mode can be selected using [roi\\_flash\\_mode](#) in [<reg\\_ctrl\\_cfg>](#) see [Section 17.3.8](#)

- FLO signal may be stuck at 1 or at 0 [roi\\_flash\\_mode](#) = h3 or h0 respectively.
- FLO1 can be calculated based on integration time only [roi\\_flash\\_mode](#) = h1
- FLO2 can be calculated based on integration time plus readout time [roi\\_flash\\_mode](#) = h2

The timings can be adjusted using [t\\_flash\\_del\\_off](#) and [t\\_flash\\_del\\_on](#) in [<reg\\_flash\\_delay>](#) see [Section 17.3.2](#)

Programming the FLO depends on the selected mode.



19.6.1 FLO in GS Mode

In this mode use only the FLO based on integration time only . (FLO1)

Figure 19-4. FLO timing, serial mode GS

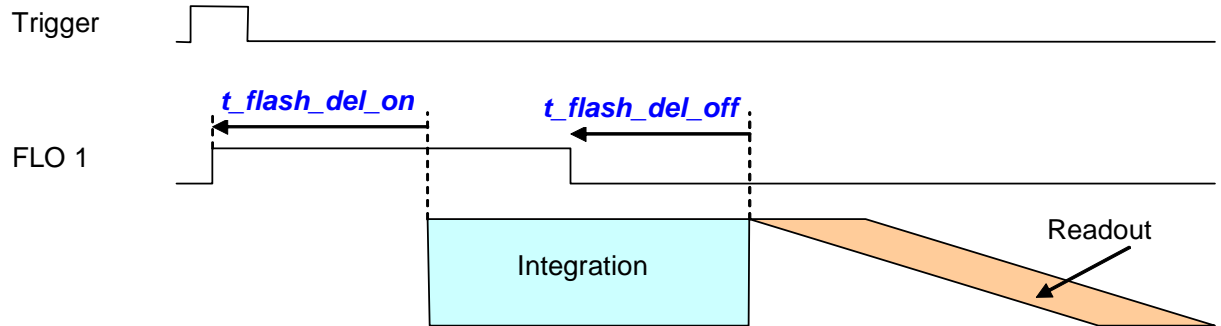
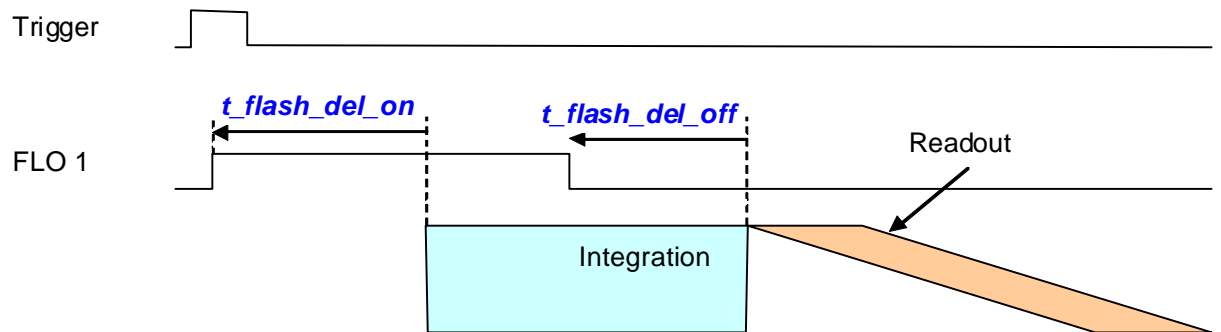

Figure 19-5. FLO timing, overlap mode GS



19.6.2 FLO in 4T + GR Mode

In this mode the FLO based on integration time only should be used. (FLO1). The Flash strobe should be switched off before readout.

Figure 19-6. FLO timing, 4T + GR mode

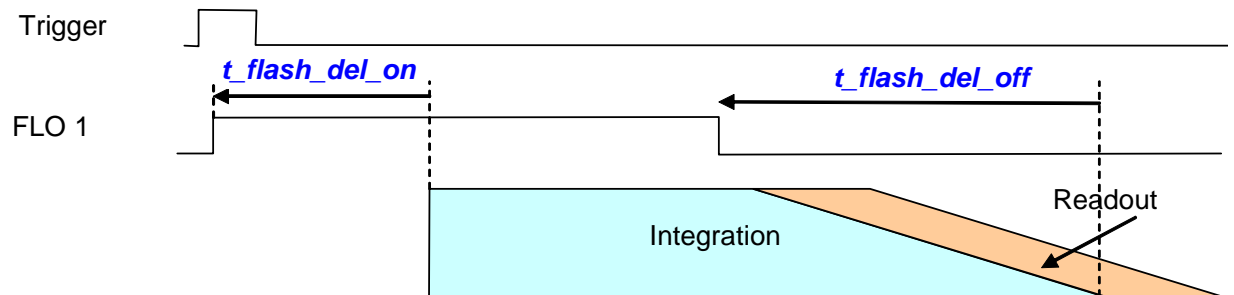

### 19.6.3 FLO in 4T ERS Mode

In this mode the FLO based on integration time + readout should be used. (FLO2). Using  $t_{flash\_del\_off}$  at 0 allows all overlap integration conditions.

**Figure 19-7.** FLO timing, serial mode ERS

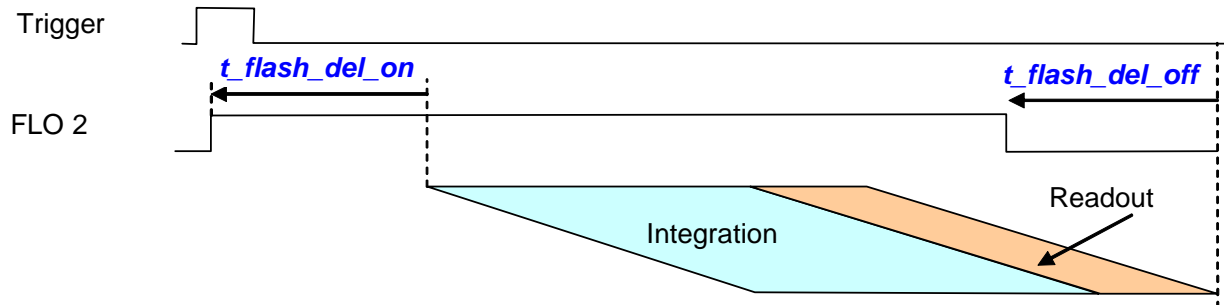
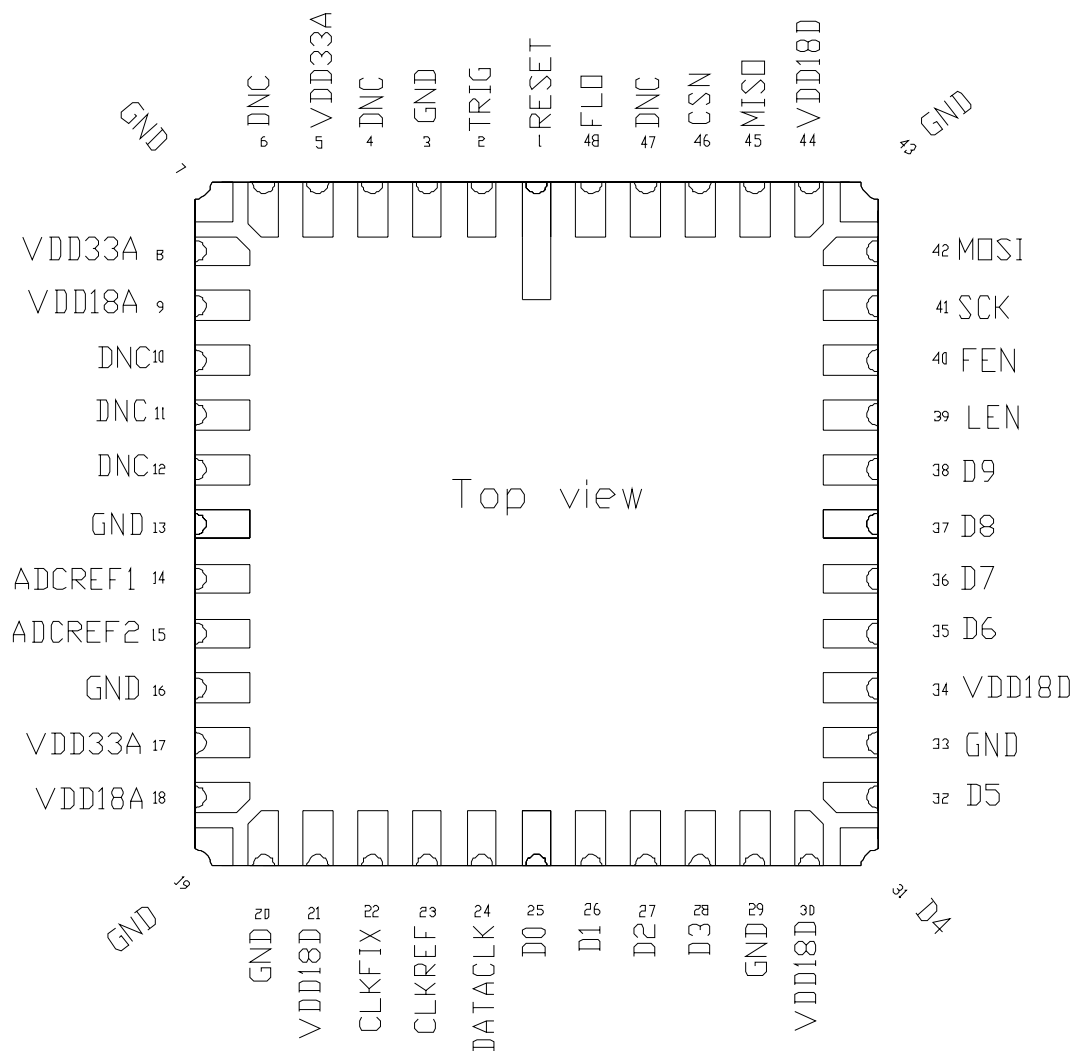



**Table 20-1.** Window Characteristics

Parameter	Specification
Window material	SCHOTT D263
Window thickness	0.55+/-0.05 mm
Window index	ne = 1.5255

**Figure 20-2.** CLCC 48 Package Pinout drawing



## 21. Input/Output List

Table 21-1. I/O list

Name	Function / Description	I/O	Pin N°
VDD33A	3.3 V supply voltage for analog domain	POWER <sup>(1)</sup>	5, 8, 17
VDD18A	1.8 V Analog power, decoupling	POWER <sup>(1)</sup>	9, 18
VDD18D	1.8 V supply voltage for digital domain	POWER <sup>(1)</sup>	21, 30, 34, 44
GND	Grounds	POWER <sup>(2)</sup>	3, 7, 13, 16, 19, 20, 29, 33, 43
Test	Test pins	DNC <sup>(3)</sup>	10, 11, 12, 47
RESETN	Reset control	IN	1
TRIG	Trigger input with pull-down	IN	2
VREFP_1	VREFP supply for matrix	DNC <sup>(3)</sup>	4
VREFP_2	VREFP supply for line decoder	DNC <sup>(3)</sup>	6
ADC_REF_1	Adjusts ADC range by inserting a resistor between these two pins.	IN/OUT	14
ADC_REF_2		IN/OUT	15
CLK_FIX	Clock input fixed	IN	22
CLK_REF	Reference Clock input	IN	23
DATA_CLK	Data output clock	OUT	24
DATA 0	Data 0	OUT	25
DATA 1	Data 1	OUT	26
DATA 2	Data 2	OUT	27
DATA 3	Data 3	OUT	28
DATA 4	Data 4	OUT	31
DATA 5	Data 5	OUT	32
DATA 6	Data 6	OUT	35
DATA 7	Data 7	OUT	36
DATA 8	Data 8	OUT	37
DATA 9	Data 9	OUT	38
LEN	Line ENable	OUT	39
FEN	Frame ENable	OUT	40
SCK	SPI Clock input	IN	41
MOSI	SPI Data Input in slave mode,	IN	42
MISO	SPI Data Output in slave mode,	OUT	45
CSN	SPI Chip Select Enable	IN	46
FLO	Flash Strobe Output	OUT	48

1. All power pins with the same name must be connected to the same power supply
2. All grounds must be connected.
3. DNC stands for Do Not Connect

## 22. Document Conventions and Acronyms

**Table 22-1.** Glossary of acronyms

B&W	Black and white
CDS	Correlated double sampling
DNC	Do not connect
DSNU	Dark signal non-uniformity
EMC	Electro Magnetic Compatibility
ERS	Electronic rolling shutter
FPN	Fixed pattern noise
fps	Frames per second
GR	Global reset
GS	Global shutter
IR	Infrared
LSB	Least significant bit
MIMR	Multiple integration multiple ROI
MSB	Most significant bit
MSL	Moisture sensitivity level
PGA	Programmable gain amplifier
PRNU	Photo response non-uniformity
ROI	Region of interest
Sat	Saturation value
SIMR	Single integration multiple ROI
SPI	Serial peripheral interface
Tint	Integration time

### 22.1 SPI Register and Bitfield Names

SPI registers and bitfield names are shown in blue bold italics as follows:

***example\_reg\_name*** for the entire register

***example\_bitfield\_name*** in ***< example\_reg\_name >*** for part of the register

### 22.2 Numbering Conventions

Hexadecimal numbers are prefixed by “h”.

In register descriptions, decimal numbers are prefixed by “d”.

## 23. Precautions for Using the Device

### 23.1 Absolute Maximum Ratings

**Table 23-1.** Absolute maximum ratings

Parameter	Value
VDD18D digital supply voltage	-0.25 V; 2.2 V
VDD18A analog supply voltage	-0.25 V; 2.2 V
VDD33A analog supply voltage	-0.25 V; 4 V
DC voltage at any input pin	-0.25 V; $V_{DD18D} + 0.25$ V
Storage temperature	-40°C to + 85°C
Operating temperature	-30°C to + 65°C

- Stresses above those listed under Absolute Maximum Ratings might cause permanent device failure. Functioning at or above these limits is not recommended.
- Exposure to absolute maximum ratings for extended periods might affect reliability.
- All power pins with the same name must be connected to the same power supply.
- All grounds must be connected.

### 23.2 ESD

The EV76C560 is resistant up to 2 kV (HBM). To avoid accumulation of charges and to prevent electrical field formation, the following precautions must be taken during manipulation:

- Wear anti-static gloves or finger cots, anti-static clothes and shoes.
- Protect workstation with a conductive ground sheet.
- Use conductive boxes.

### 23.3 Cleaning the Window

The EV76C560 sensor is an optical device. All precautions must be taken to prevent dust or scratches on the input window. If the window needs to be cleaned, use the procedure described here.

#### 23.3.1 Equipment

- Ethanol.
- Cleaning medium (wipes, optical paper, cotton buds).
- Filtered blow-off gun (preferably with static charge neutralizing capability).
- Area protected from electrostatic discharges and equipped with ground straps.

#### 23.3.2 Preparations

- Wear vinyl gloves or finger cots without talcum powder.
- Make use of anti-ESD equipment: ground straps, ionizers etc.

#### 23.3.3 Recommendations

- Never clean with a dry cleaning medium.
- Soak the cleaning medium with alcohol and do not pour it directly on the window.
- Clean the window only if necessary.

#### 23.3.4 Operating Procedure

- Clean the glass window with an air-jet (using the blow-off gun).
- If stains or dust remain;
  - Soak the cleaning medium with alcohol and wipe the glass window in a single movement from one side to another.
  - Always use a clean part of the cleaning medium for each new attempt.
  - Adapt the speed of the wiping action to let alcohol evaporate without leaving traces.
  - Optionally, use the blow-off gun to clean the window once more.

### 24. Standards Compliance

The EV76C560 sensor conforms to the following standards:

- RoHS compliant
- Product qualification according to JEDEC JESD47
- MSL 3 compliant

### 25. Ordering Codes

- EV76C560ABT-EQV for Black and White product
- EV76C560ACT-EQV for Bayer product

For other packaging or other CFA please contact e2v.

The sensors are delivered in Jedec trays.



## Table of Contents

<b>1</b>	<b><i>Typical Performance Data</i></b> .....	<b>2</b>
<b>2</b>	<b><i>Sensor Overview</i></b> .....	<b>3</b>
<b>3</b>	<b><i>Standard Configuration</i></b> .....	<b>4</b>
	3.1 Sensor Settings .....	4
	3.2 Application Information .....	5
	3.3 Electrical Levels .....	6
<b>4</b>	<b><i>Matrix</i></b> .....	<b>7</b>
	4.1 Useful Area Definition .....	7
	4.2 CFA (Color Filter Array) .....	8
	4.3 Pixels .....	8
	4.4 Lens CRA (Chief Ray Angle) compensation. ....	8
	4.5 Region Of Interest (ROI) .....	11
<b>5</b>	<b><i>10-Bit ADC</i></b> .....	<b>21</b>
	5.1 Analog Gain .....	21
	5.2 External Resistor Choice .....	22
	5.3 Analog Gain Tolerances .....	22
<b>6</b>	<b><i>Clamp and Offset Adjustment</i></b> .....	<b>22</b>
<b>7</b>	<b><i>Digital Gain</i></b> .....	<b>25</b>
<b>8</b>	<b><i>Defective Pixel Correction</i></b> .....	<b>25</b>
<b>9</b>	<b><i>Binning</i></b> .....	<b>26</b>
<b>10</b>	<b><i>Histograms</i></b> .....	<b>27</b>
<b>11</b>	<b><i>10 to 8-Bit Compression</i></b> .....	<b>28</b>
<b>12</b>	<b><i>Context</i></b> .....	<b>29</b>
<b>13</b>	<b><i>Mux Out</i></b> .....	<b>31</b>
<b>14</b>	<b><i>Timing Generator and Power Management</i></b> .....	<b>31</b>
<b>15</b>	<b><i>Clock Generator</i></b> .....	<b>32</b>
	15.1 PLL .....	33
	15.2 Internal Oscillator .....	35
	15.3 Nominal Clock Configurations .....	36

<b>16</b>	<b><i>Test Pattern Generator</i></b> .....	<b>36</b>
16.1	Moving Test Pattern .....	37
16.2	Fixed Test Pattern .....	38
16.3	Functional Test Pattern .....	38
<b>17</b>	<b><i>SPI</i></b> .....	<b>39</b>
17.1	Register Summary Tables .....	39
17.2	8-Bit Register Descriptions .....	45
17.3	16-Bit Register Descriptions .....	47
17.4	SPI Timing .....	80
<b>18</b>	<b><i>Sensor States</i></b> .....	<b>82</b>
18.1	Static States .....	82
18.2	Active States .....	83
18.3	Interrupt Functions .....	89
<b>19</b>	<b><i>Synchronization Pulse and Timings</i></b> .....	<b>91</b>
19.1	Clock Limits .....	91
19.2	Vertical Timings .....	92
19.3	Horizontal Timings .....	94
19.4	Line_length Calculation .....	95
19.5	Pixel Timings .....	96
19.6	FLO (Flash Strobe Output) .....	96
<b>20</b>	<b><i>Package Specification</i></b> .....	<b>99</b>
<b>21</b>	<b><i>Input/Output List</i></b> .....	<b>101</b>
<b>22</b>	<b><i>Document Conventions and Acronyms</i></b> .....	<b>102</b>
22.1	SPI Register and Bitfield Names .....	102
22.2	Numbering Conventions .....	102
<b>23</b>	<b><i>Precautions for Using the Device</i></b> .....	<b>103</b>
23.1	Absolute Maximum Ratings .....	103
23.2	ESD .....	103
23.3	Cleaning the Window .....	103
<b>24</b>	<b><i>Standards Compliance</i></b> .....	<b>104</b>
<b>25</b>	<b><i>Ordering Codes</i></b> .....	<b>104</b>
<b>26</b>		



## How to reach us

Home page: [www.e2v.com](http://www.e2v.com)

### Sales offices:

#### **Europe Regional sales office**

##### **e2v ltd**

106 Waterhouse Lane  
Chelmsford Essex CM1 2QU  
England  
Tel: +44 (0)1245 493493  
Fax:: +44 (0)1245 492492  
E-Mail: [enquiries@e2v.com](mailto:enquiries@e2v.com)

##### **e2v sas**

16 Burospace  
F-91572 Bièvres Cedex  
France  
Tel: +33 (0) 16019 5500  
Fax: +33 (0) 16019 5529  
E-Mail: [enquiries-fr@e2v.com](mailto:enquiries-fr@e2v.com)

##### **e2v gmbh**

Industriestraße 29  
82194 Gröbenzell  
Germany  
Tel: +49 (0) 8142 41057-0  
Fax:: +49 (0) 8142 284547  
E-Mail: [enquiries-de@e2v.com](mailto:enquiries-de@e2v.com)

#### **Americas**

##### **e2v inc**

520 White Plains Road  
Suite 450 Tarrytown NY 10591  
USA  
Tel: +1 (914) 592 6050 or 1-800-342-5338,  
Fax:: +1 (914) 592-5148  
E-Mail: [enquiries-na@e2v.com](mailto:enquiries-na@e2v.com)

#### **Asia Pacific**

##### **e2v ltd**

11/F.,  
Onfem Tower,  
29 Wyndham Street,  
Central, Hong Kong  
Tel: +852 3679 364 8/9  
Fax: +852 3583 1084  
E-Mail: [enquiries-ap@e2v.com](mailto:enquiries-ap@e2v.com)

#### **Product Contact:**

##### **e2v**

Avenue de Rochepleine  
BP 123 - 38521 Saint-Egrève Cedex  
France  
Tel: +33 (0)4 76 58 30 00

##### **Hotline:**

[hotline.EyeOnSi@e2v.com](mailto:hotline.EyeOnSi@e2v.com)

Whilst e2v has taken care to ensure the accuracy of the information contained herein it accepts no responsibility for the consequences of any use thereof and also reserves the right to change the specification of goods without notice. e2v accepts no liability beyond that set out in its standard conditions of sale in respect of infringement of third party patents arising from the use of tubes or other devices in accordance with information contained herein.