

QUADRUPLE Analog to Digital Converter High Bandwidth, Low power, Low input Swing QUAD 8-bit 1.25 GSps ADC operating up to 5 GSps

Datasheet

Main Features

- Quad ADC with 8-bit Resolution using e2v Proprietary Analog input Cross-point Switch
 - 1.25 GSps Sampling Rate in 4-channel Mode
 - 2.5 GSps Sampling Rate in 2-channel Mode
 - 5 GSps Sampling Rate in 1-channel Mode
 - Built-in four-by-four Cross Point Switch
- Single 2.5 GHz Differential Symmetrical Input Clock
- 250 mVpp Analog Input (Differential AC or DC Coupled)
- ADC Master Reset (LVDS)
- Double Data Rate Output Protocol
- LVDS Output Format
- Digital Interface (SPI) with Reset Signal:
 - Channel Mode Selection
 - Selectable Bandwidth (2 Available Settings)
 - Gain, Offset, Phase Control
 - Standby Mode (Full or Partial)
 - Binary or Gray Coding Selection
 - Test Modes (Ramp, Flashing "1")
- Power Supplies: 3.3V & 1.8V
- Reduced Clock induced Transients on Power Supply Pins due to BiCMOS Silicon Technology
- Power Dissipation: 1.4W per Channel
- EBGA380 Package (RoHS & non RoHS, 1.27 mm Pitch)



Performance

- Selectable Full Power Input Bandwidth (–3 dB) up to 3.2 GHz (4-2-1 Channel Mode)
- Band Flatness: ± 0.5 dB from DC to 30% of Full Power Input Bandwidth
- Channel-To-Channel Isolation: > 60 dB
- 4-channel Mode (Fsampling = 1.25 GSps, –1 dBFS)
 - Fin = 100 MHz (Bandwidth 1 GHz): ENOB = 7.1 bit, SFDR = 47 dBc, SNR = 45 dB, DNL = 0.35 LSB, INL = ± 0.5 LSB
 - Fin = 620 MHz (Full Bandwidth): ENOB = 7.0 bit, SFDR = 47 dBc, SNR = 44.5 dB
 - Fin = 1.2 GHz (Full Bandwidth): ENOB = 6.7 bit, SFDR = 47 dBc, SNR = 42.5 dB
- 2-channel or 1-channel Mode (Fsampling = 2.5 or 5 GSps, Fin = 620 MHz, –1 dBFS)
 - Fin = 620 MHz (Full Bandwidth): ENOB = 7.0 bit, SFDR = 48 dBc, SNR = 44 dB
 - Fin = 1.2 GHz (Full Bandwidth): ENOB = 6.7 bit, SFDR = 48 dBc, SNR = 42 dB
- BER: 10^{-16} at Full Speed
- Latency: 4-channel: 6.5 Clock Cycles

Visit our website: www.e2v.com
for the latest version of the datasheet

Applications

- High Speed Data Acquisition
- Direct RF Down Conversion
- Ultra Wideband Satellite Digital Receiver
- 16 Gbps pt-pt Microwave Receivers
- High Energy Physics
- Automatic Test Equipment
- High Speed Test Instrumentation
- LiDAR (Light Detection And Ranging)

1. Block Diagram

Figure 1-1. Simplified Block Diagram

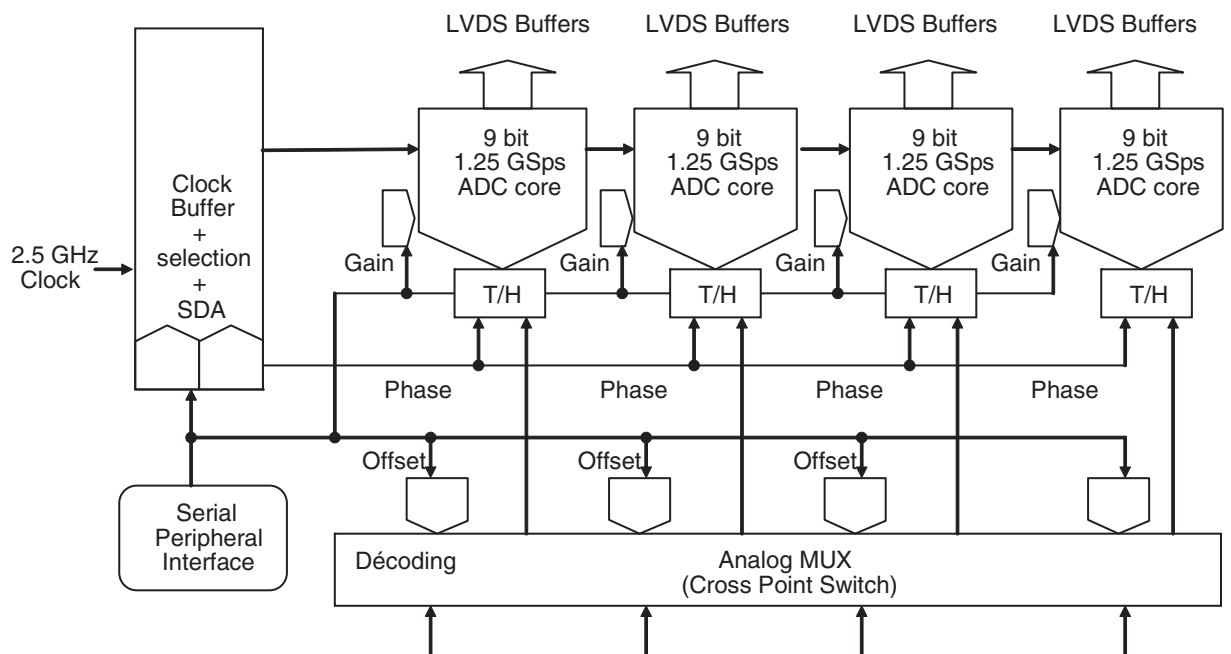

2. Description

The Quad ADC is made up of four 9-bit ADC cores which can be considered independently (4-channel mode) or grouped by 2 x 2 cores (2-channel mode with the ADCs interleaved two by two) or 1-channel mode (where all four ADCs are all interleaved together).

All four ADCs are clocked by the same external input clock signal and controlled via an industry standard SPI (Serial Peripheral Interface). An analog multiplexer (Cross point Switch) is used to select the analog inputs depending on the mode the Quad ADC is used in.

Important notice/Disclaimer:

All figures hereafter are given for a full scale of 250 mVpp equivalent to the 256 codes available in the Quad8 HiBW range, ie only when bit 7 = 1 in Gray coding. Yet 9 bits are provided (which is 512 codes), this product is tested and guaranteed only for behaviour of the 256 central codes, this is why it is sold and priced as an 8 bit. Any use beyond the 256 central codes would be under the sole responsibility of the customer without guarantee from e2v.

The **Clock Circuit** is common to all four ADCs. This block receives an external 2.5 GHz clock (maximum frequency) and preferably a low jitter sinewave signal. In this block, the external clock signal is then divided by two in order to generate the internal sampling clocks:

- in 4-channel mode, the same 1.25 GHz clock is directed to all four ADC cores and T/H;
- in 2-channel mode, the in-phase 1.25 GHz clock is sent to ADC A or C and the inverted 1.25 GHz clock is sent to ADC B or D, while the analog input is sent to both ADCs, resulting in an interleaved mode with an equivalent sampling frequency of 2.5 GSps;
- in 1-channel mode, the in-phase 1.25 GHz clock is sent to ADC A while the inverted 1.25 GHz clock is sent to ADC B, the in-phase 1.25 GHz clock is delayed by 90° to generate the clock for ADC C and the inverted 1.25 GHz clock is delayed by 90° to generate the clock for ADC D, resulting in an interleaved mode with an equivalent sampling frequency of 5 GSps.

Note: This document should be used in conjunction with the other documentation relating to this product, e.g. Application notes, Errata notes etc.

Several adjustments for the sampling delay and the phase are included in this clock circuit to ensure a proper phase relation between the different clocks generated internally from the 2.5 GHz clock.

The **Cross point** switch (Analog MUX) is common to all ADCs. It allows to select which analog input has been chosen by the user:

- in 4-channel mode, each analog input is sent to the corresponding ADC (AAI to ADC A, BAI to ADC B, CAI to ADC C and DAI to ADC D);
- in 2-channel mode, one can consider that there are two independent ADCs composed of ADC A and B for the first one and of ADC C and D for the second one; the two analog inputs can be applied on AAI or on BAI for the first ADC (in which case, the signal is redirected internally to the second ADC of the pair - ie. B or A respectively) and on CAI or DAI (in which case, the signal is redirected internally to the second ADC of the pair - ie. D or C respectively);
- in 1-channel mode, one analog input is chosen among AAI, BAI, CAI and DAI and then sent to all four ADCs.

Figure 2-1. 4-channel Mode Configuration

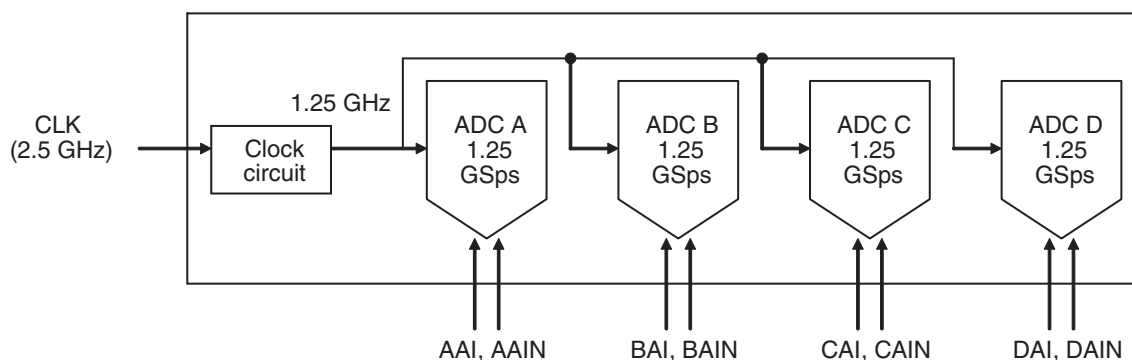

Note: Refer to [Figure 3-1 on page 15](#)

Figure 2-2. 2-channel Mode Configuration (Analog Input A and Analog Input C)

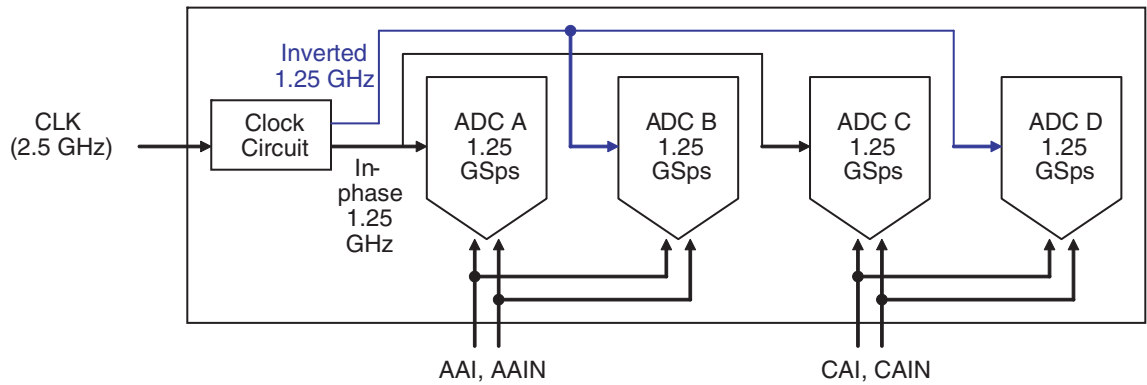

Note: refer to [Figure 3-2 on page 16](#)

Figure 2-3. 2-channel Mode Configuration (Analog Input A and Analog Input D)

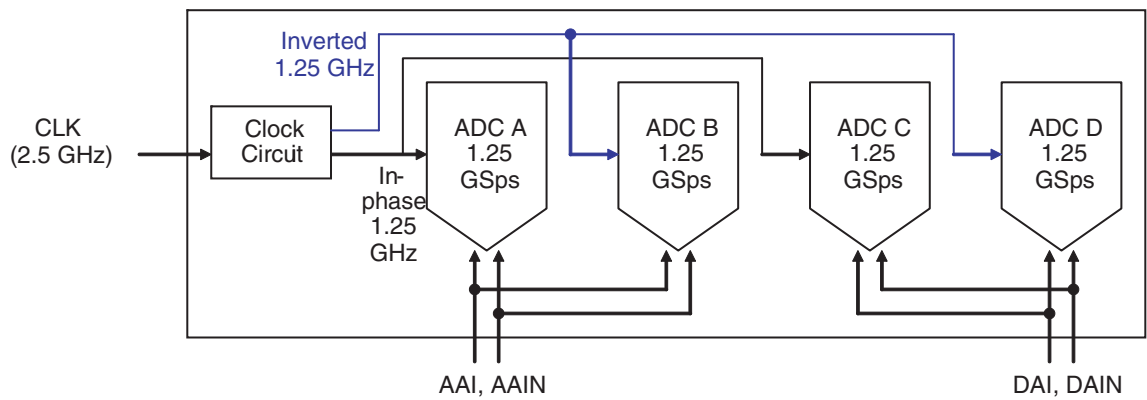

Note: refer to [Figure 3-2 on page 16](#)

Figure 2-4. 2-channel Mode Configuration (Analog Input B and Analog Input C)

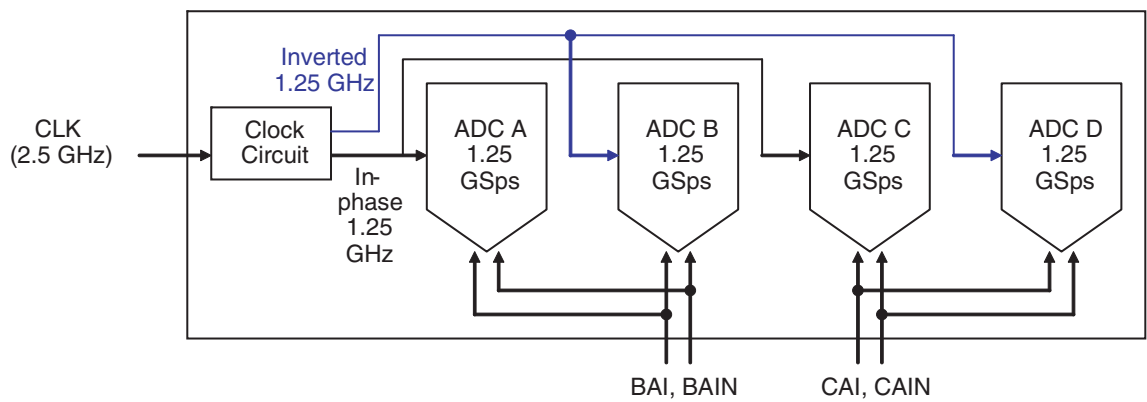

Note: refer to [Figure 3-2 on page 16](#)

Figure 2-5. 2-channel Mode Configuration (Analog Input B and Analog Input D)

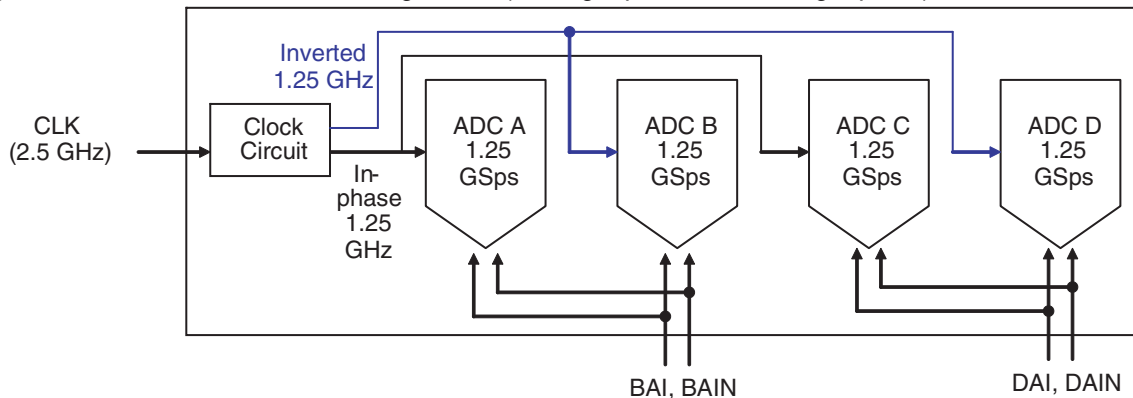

Note: Refer to [Figure 3-2 on page 16](#)

Figure 2-6. 1-channel Mode Configuration

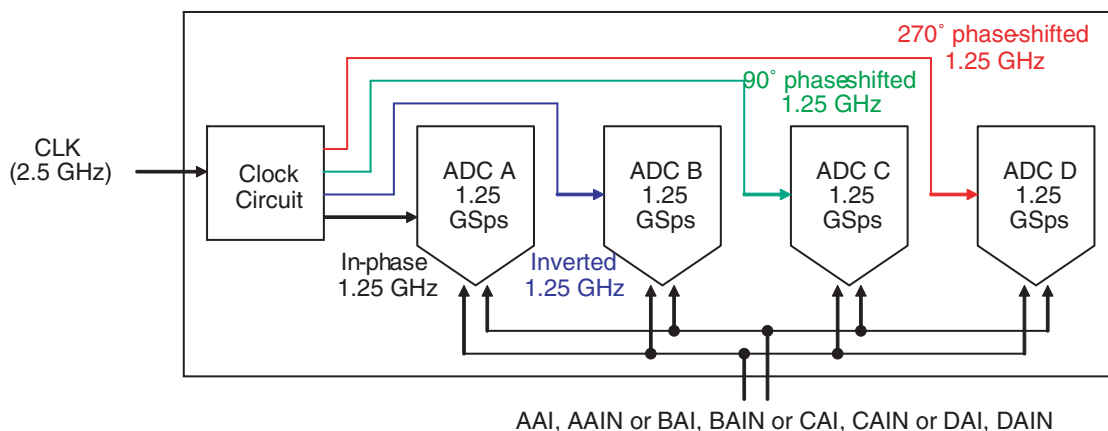

- Notes:
1. Refer to [Figure 3-3 on page 17](#)
 2. For simplification purpose of the timer circuit, the temporary order of ports for sampling is A C B D, therefore sampling order at output port is as follows:
 A: $N, N + 4, N + 8, N + 12 \dots$
 C: $N + 1, N + 5, N + 9 \dots$
 B: $N + 2, N + 6, N + 10 \dots$
 D: $N + 3, N + 7, N + 11 \dots$

The **T/H** (Track and Hold) is located after the Cross Point Switch and before the ADC cores. This block is used to track the data when the internal sampling clock is low and to hold the data when the internal sampling clock is high. This stage has a gain of 2.

The **ADC cores** are all the same for the four ADCs. They include a quantifier block as well as a fast logic block composed of regenerating latches and the Binary/Gray decoding block.

The **SPI block** provides the digital interface for the digital controls of the ADCs. All the functions of the ADC are contained in the SPI registers and controlled via this SPI (channel selection, standby mode, Binary or Gray coding, Offset Gain and Phase adjust..).

The **Output buffers** are LVDS compatible. They should be terminated using a 100 external termination resistor.

The **ADC SYNC buffer** is also LVDS compatible. When active, the SYNC signal makes the output clock signals go low. The output data are undetermined during the reset and until the output clock restarts.

When the SYNC signal is released, the output clock signals restart after TDR + pipeline delay + a certain number of input clock cycles which is programmed via the SPI in the SYNC register (from min delay to min delay + 15 x 2 input clock cycles).

A **Diode** for the die junction temperature monitoring is implemented using a diode-mounted transistor but not connected to the die: both cathode and anode are accessible externally.

Eight **DACs for the gain and the offset controls** are included in the design and are addressed through the SPI:

- Offset DACs are used close to the cross point switch;
- Gain DACs are used on the biasing of the reference ladders of each ADC core.

These DACs have a resolution of 10-bit and will allow the control via the SPI of the offset and gain of the ADCs:

- Gain adjustment on 1024 steps, $\pm 10\%$ range;
- Offset adjustment on 1024 steps, ± 40 LSB range

Four **DACs for fine phase control** are included in the design and are addressed through the SPI, they have a 10-bit resolution, and a tuning range of ± 15 ps (1 step is about 30 fs).

3. Specifications

3.1 Absolute Maximum Ratings

Table 3-1. Absolute Maximum ratings

| Parameter | Symbol | Value | Unit |
|---|-------------------------|------------------------------------|-----------------|
| Positive supply voltage (analog core + SPI pads) | V_{CC} | 4 | V |
| Positive Digital supply voltage | V_{CCD} | 2.5 | V |
| Positive Digital supply voltage | V_{CCO} | 2.5 | V |
| Analog input voltages | V_{IN} or V_{INN} | GND – 0.3 (min) VCC + 0.3 (max) | V |
| Maximum difference between V_{IN} and V_{INN} | $V_{IN} - V_{INN}$ | 4 | V |
| Clock input voltage | V_{CLK} or V_{CLKN} | GND – 0.3 (min) VCC + 0.3 (max) | V |
| Maximum difference between V_{CLK} and V_{CLKN} | $V_{CLK} - V_{CLKN}$ | 4 | V _{pp} |
| Junction Temperature | T_J | 125 | °C |
| Storage Temperature | T_{stg} | –55 to 150 | °C |

Note: Absolute maximum ratings are limiting values (referenced to GND = 0V), to be applied individually, while other parameters are within specified operating conditions. Long exposure to maximum rating may affect device reliability.
All integrated circuits have to be handled with appropriate care to avoid damages due to ESD. Damage caused by inappropriate handling or storage could range from performance degradation to complete failure. No power sequence recommendation. The power supplies can be switched on and off in any order

3.2 Recommended Conditions Of Use

Table 3-2. Absolute Maximum Ratings

| Parameter | Symbol | Comments | Recommended Value | Unit |
|--|---|--|---|--------------------|
| Positive supply voltage | V_{CC} | Includes SPI pads | 3.3 | V |
| Positive digital supply voltage | V_{CCD} | Digital parts | 1.8 | V |
| Positive Output supply voltage | V_{CCO} | Output buffers | 1.8 | V |
| Differential analog input voltage (Full Scale) | V_{IN}, V_{INN} $V_{IN} - V_{INN}$ | | ± 125 250 | mV mVpp |
| Clock input power level | P_{CLK}, P_{CLKN} | | 0 | dBm |
| Digital CMOS input | V_D | VIL VIH | 0 V_{CC} | V |
| Clock frequency | F_c | For operation at 1.25 GSps in 4-channel mode or 2.5 GSps in 2-channel mode or 5 GSps in 1-channel mode | = 2.5 | GHz |
| Operating Temperature Range | T_a | Commercial "C" grade Industrial « V » grade | $0^{\circ}\text{C} < T_C ; T_J < 90^{\circ}\text{C}$ $-40^{\circ}\text{C} < T_C ; T_J < 110^{\circ}\text{C}$ | $^{\circ}\text{C}$ |

3.3 Electrical Characteristics for supplies, Inputs and Outputs

Unless otherwise specified:

$$V_{CC} = 3.3\text{V}, V_{CCD} = 1.8\text{V}, V_{CCO} = 1.8\text{V}$$

-1 dBFS Analog input (Full Scale Input: $V_{IN} - V_{INN} = 250$ mVpp), Full scale is delimited by state of bit 7 in Gray coding, this bit will yield low logic level for signal excursion exceeding the Full Scale. Clock input differentially driven; analog input differentially driven. Default mode: 4-channel mode ON, Binary output data format, Standby mode OFF, Full bandwidth.

Table 3-3. Electrical characteristics for Supplies, Inputs and Outputs

| Parameter | Test Level | Symbol | Min | Typ | Max | Unit |
|--|------------|------------------------------------|--------------------|--------------------|--------------------|----------------|
| RESOLUTION | | | | 10 | | bit |
| POWER REQUIREMENTS | | | | | | |
| Power Supply voltage - Analog (and SPI pads) - Digital - Output | 1.4 | V_{CC} V_{CCD} V_{CCO} | 3.15 1.7 1.7 | 3.3 1.8 1.8 | 3.45 1.9 1.9 | V V V |
| Power Supply current - Analog (and SPI pads) - Digital - Output | 1.4 | I_{CC} I_{CCD} I_{CCO} | | 1.6 1.58 166 | 1.89 3 215 | A mA mA |
| Power Supply current (Partial standby mode AB) - Analog (and SPI pads) - Digital - Output | 1.4 | I_{CC} I_{CCD} I_{CCO} | | 886 1.59 92 | 980 3 120 | mA mA mA |

Table 3-3. Electrical characteristics for Supplies, Inputs and Outputs (Continued)

| Parameter | Test Level | Symbol | Min | Typ | Max | Unit |
|--|------------|------------------------------------|------------|------------------------------|------------------------------|------------------|
| Power Supply current (Partial standby mode CD) - Analog (and SPI pads) - Digital - Output | 1.4 | I_{CC} I_{CCD} I_{CCO} | | 904 1.59 92 | 1090 3 120 | mA mA mA |
| Power Supply current (Full standby mode) - Analog (and SPI pads) - Digital - Output | 1.4 | I_{CC} I_{CCD} I_{CCO} | | 179 1.61 19 | 255 3 25 | mA mA mA |
| Power dissipation Default mode Partial Standby mode (AB) Partial standby mode (CD) Full Standby mode | 1.4 | P_D | | 5.60 3.15 3.15 0.62 | 5.80 3.55 3.55 0.87 | W W W W |
| DATA INPUTS | | | | | | |
| Full Scale Input Voltage range (differential mode) | 1.4 | V_{IN} V_{INN} | | 125 125 | | mVpp mVpp |
| Input Common Mode | 1.4 | V_{ICM} | 1.56 | 1.57 | 1.6 | V |
| Analog input capacitance (die) | 4 | C_{IN} | | 0.5 | | pF |
| Input Resistance (differential) (see note) | 1.4 | R_{IN} | 95 | 100 | 120 | Ω |
| CLOCK INPUTS | | | | | | |
| Source Type | 4 | Differential Sinewave | | | | |
| Clock input common mode voltage | 1.4 | V_{CM} | 1.65 | 1.75 | 1.85 | V |
| Clock input power level (low phase noise sinewave input) 100 Ω differential, AC coupled signal | 4 | P_{CLK} | -9 | 0 | 2 | dBm |
| Clock input swing (differential voltage) – on each clock input | 1.4 | V_{CLK} , V_{CLKN} | 150 150 | 450 450 | 565 565 | mVpp mVpp |
| Clock input capacitance (die + package) | 4 | C_{CLK} | | 0.5 | | pF |
| Clock input resistance (differential) | 1.4 | R_{CLK} | 90 | 100 | 110 | Ω |
| Clock Jitter (max. allowed on clock source) For 1 GHz sinewave analog input | 4 | Jitter | | | 150 | fs |
| Clock Duty Cycle requirement in 1-channel mode for performance | 4 | Duty Cycle | 48 | 50 | 52 | % |
| Clock Duty Cycle requirement in 2-channel mode for performance | 4 | Duty Cycle | 40 | 50 | 60 | % |
| Clock Duty Cycle requirement in 4-channel mode for performance | 4 | Duty Cycle | 40 | 50 | 60 | % |

Table 3-3. Electrical characteristics for Supplies, Inputs and Outputs (Continued)

| Parameter | Test Level | Symbol | Min | Typ | Max | Unit |
|--|------------|--|---------------------|-------------|---------------------|-------------------|
| SYNC, SYNCN Signal | | | | | | |
| Logic Compatibility | 1.4 | LVDS | | | | |
| Input Voltages to be applied - Logic Low - Logic High - Swing - Common Mode | 1.4 | V_{IL} V_{IH} $V_{IH} - V_{IL}$ V_{ICM} | 1.4 | 330 1.25 | 1.1 | V V mV V |
| SYNC, SYNCN input capacitance | 4 | CSYNC | | 0.5 | | pF |
| SYNC, SYNCN input resistance | 4 | RSYNC | | 100 | | Ω |
| SPI | | | | | | |
| CMOS low level input voltage | 1.4 | V_{ilc} | 0 | | $0.3 \cdot V_{CC}$ | V |
| CMOS high level input voltage | 1.4 | V_{ihc} | $0.7 \cdot V_{CC}$ | | V_{CC} | V |
| CMOS low level of Schmitt trigger | 1.4 | $V_{tminusc}$ | | | $0.35 \cdot V_{CC}$ | V |
| CMOS high level of Schmitt trigger | 1.4 | V_{tplusc} | $0.65 \cdot V_{CC}$ | | | V |
| CMOS Schmitt trigger hysteresis | 1.4 | V_{hystc} | $0.15 \cdot V_{CC}$ | | | V |
| CMOS low level output voltage (I _{olc} = 2 or 3 mA) | 1.4 | V_{olc} | | | 0.4 | V |
| CMOS high level output voltage (I _{ohc} = 2 or 3 mA) | 1.4 | V_{ohc} | $0.8 \cdot V_{CC}$ | | | V |
| CMOS low level input current (V _{inc} = 0 V) | 1.4 | I_{ilc} | | | 10 | nA |
| CMOS high level input current (V _{inc} = V _{CC}) | 1.4 | I_{ihc} | | | 165 | nA |
| DIGITAL DATA and DATA READY OUTPUTS (see Note) | | | | | | |
| Logic Compatibility | 1, 4 | LVDS | | | | |
| Output levels 50 Ω transmission lines, 100 Ω (2 x 50 Ω) differentially terminated - Swing (each single-ended output) - Common mode | 1.4 | $V_{OH} - V_{OL}$ V_{OCM} | 250 1.125 | | 450 1.375 | mV V |

- Notes: 1. Input impedance can be adjusted via register at address 0x13.
2. Differential output buffers impedance = 100 Ω differential.

3.4 Converter Characteristics

Unless otherwise specified:

$$V_{CC} = 3.3V, V_{CCD} = 1.8V, V_{CCO} = 1.8V$$

-1 dBFS Analog input (Full Scale Input: $V_{IN} - V_{INN} = 250$ mVpp)

Clock input differentially driven; analog input differentially driven.

Default mode: 4-channel mode ON, Binary output data format, Standby mode OFF, full bandwidth

Table 3-4. Low Frequency Characteristics

| Parameter | Test Level | Symbol | Min | Typ | Max | Unit |
|---|------------|--------|-------|-------|------|--------|
| DC ACCURACY | | | | | | |
| Gain central value (see note ⁽¹⁾) | 1.4 | | 0.9 | 1 | 1.1 | |
| Gain error drift | 4 | | | 325 | | ppm/°C |
| Input offset voltage (see note ⁽²⁾) | 1.4 | | 116 | 128 | 140 | LSB |
| 4-Channel Mode (Fsampling = 1.25 GSps, Fin = 100 MHz, -1 dBFS), for each channel | | | | | | |
| DNLrms | 1.4 | DNLrms | | 0.1 | 0.15 | LSB |
| Differential non linearity | 1.4 | DNL+ | | 0.2 | 0.35 | LSB |
| Differential non linearity | 1.4 | DNL- | -0.35 | -0.2 | | LSB |
| INLrms | 1.4 | INLrms | | 0.2 | 0.5 | LSB |
| Integral non linearity | 1.4 | INL- | -0.9 | -0.4 | | LSB |
| Integral non linearity | 1.4 | INL+ | | 0.4 | 0.9 | LSB |
| 2-Channel Mode (Fsampling = 2.5 GSps, Fin = 100 MHz, -1 dBFS), for each channel | | | | | | |
| DNLrms | 1.4 | DNLrms | | 0.09 | 0.15 | LSB |
| Differential non linearity | 1.4 | DNL+ | | 0.2 | 0.35 | LSB |
| Differential non linearity | 1.4 | DNL- | -0.35 | -0.2 | | LSB |
| INLrms | 1.4 | INLrms | | 0.2 | 0.6 | LSB |
| Integral non linearity | 1.4 | INL- | -0.8 | -0.4 | | LSB |
| Integral non linearity | 1.4 | INL+ | | 0.4 | 0.8 | LSB |
| 1-Channel Mode (Fsampling = 5 GSps, Fin = 100 MHz, -1 dBFS) | | | | | | |
| DNLrms | 1.4 | DNLrms | | 0.06 | 0.1 | LSB |
| Differential non linearity | 1.4 | DNL+ | | 0.2 | 0.5 | LSB |
| Differential non linearity | 1.4 | DNL- | -0.5 | -0.2 | | LSB |
| INLrms | 1.4 | INLrms | | 0.2 | 0.5 | LSB |
| Integral non linearity | 1.4 | INL- | -0.6 | -0.35 | | LSB |
| Integral non linearity | 1.4 | INL+ | | 0.35 | 0.6 | LSB |

Notes: 1. Gain central value can be set to "1" via the gain adjustment function of the SPI at register 0x22. Gain central value is measured at $F_{in} = 100$ MHz.

2. Offset can be adjusted to 0 LSB via the offset adjustment function of the SPI at register 0x20

Table 3-5. Dynamic Characteristics

| Parameter | Symbol | Test Level | Min | Typ | Max | Unit | Note |
|--|--------|------------|------|-----|------|------|------|
| AC ANALOG INPUTS | | | | | | | |
| Full Power Input Bandwidth in Full mode (BW = "1" in 0x01 register) | FPBW | 4 | | 3.2 | | GHz | (1) |
| Full Power Input Bandwidth in Nominal mode (BW = "0" in 0x01 register, default mode) | | | | 1.5 | | GHz | |
| Gain Flatness (± 0.5 dB in full band mode setting BW = "1" in 0x01 register) | GF | 4 | | 1.5 | | GHz | |
| Input Voltage Standing Wave Ratio up to 3 GHz | VSWR | 4 | | | 2.13 | | (2) |
| Crosstalk (Fin = 620 MHz) | | 4 | | 60 | | dB | |
| Dynamic Performance – 4-Channel Mode (Fsampling = 1.25 GSps, Vin = -1 dBFS) for each channel (after calibration) | | | | | | | |
| Effective Number Of Bits Fs = 1.25 GSps Fin = 100 MHz Fs = 1.25 GSps Fin = 620 MHz Fs = 1.25 GSps Fin = 1200 MHz | ENOB | 1.4 | 7.1 | 7.3 | | Bit | (3) |
| | | | 7.0 | 7.2 | | | |
| | | | 6.7 | 6.9 | | | |
| Signal to Noise Ratio Fs = 1.25 GSps Fin = 100 MHz Fs = 1.25 GSps Fin = 620 MHz Fs = 1.25 GSps Fin = 1200 MHz | SNR | 1.4 | 45 | 46 | | dB | (3) |
| | | | 44.5 | 45 | | | |
| | | | 42.5 | 43 | | | |
| Total Harmonic Distortion (9 Harmonics) Fs = 1.25 GSps Fin = 100 MHz Fs = 1.25 GSps Fin = 620 MHz Fs = 1.25 GSps Fin = 1200 MHz | ITHDI | 1.4 | 46 | 54 | | dB | (3) |
| | | | 46 | 53 | | | |
| | | | 46 | 53 | | | |
| Spurious Free Dynamic Range Fs = 1.25 GSps Fin = 100 MHz Fs = 1.25 GSps Fin = 620 MHz Fs = 1.25 GSps Fin = 1200 MHz | ISFDRI | 1.4 | 47 | 57 | | dBc | (3) |
| | | | 47 | 55 | | | |
| | | | 47 | 53 | | | |
| Two tone third order intermodulation distortion Fs = 1.25 GSps Fin1 = 490 MHz ; Fin2 = 495 MHz [-7dBFS] | IIMD3I | 4 | | 53 | | dBFS | (3) |
| Dynamic Performance – 2 Channel Mode at 1.25 Gsps or 1-Channel Mode at 2.5 GSps, -1 dBFS (after calibration) | | | | | | | |
| Effective Number Of Bits Fs = 2.5 GSps Fin = 100 MHz Fs = 2.5 GSps Fin = 620 MHz Fs = 2.5 GSps Fin = 1200 MHz | ENOB | 1.4 | | 7.3 | | Bit | (3) |
| | | | 7.0 | 7.2 | | | |
| | | | 6.7 | 7.0 | | | |
| Signal to Noise Ratio Fs = 2.5 GSps Fin = 100 MHz Fs = 2.5 GSps Fin = 620 MHz Fs = 2.5 GSps Fin = 1200 MHz | SNR | 1.4 | | 46 | | dB | (3) |
| | | | 44 | 45 | | | |
| | | | 42 | 43 | | | |
| Total Harmonic Distortion (9 Harmonics) Fs = 2.5 GSps Fin = 100 MHz Fs = 2.5 GSps Fin = 620 MHz Fs = 2.5 GSps Fin = 1200 MHz | ITHDI | 1.4 | | 54 | | dB | (3) |
| | | | 48 | 54 | | | |
| | | | 46 | 53 | | | |

Table 3-5. Dynamic Characteristics (Continued)

| Parameter | Symbol | Test Level | Min | Typ | Max | Unit | Note |
|--|--------|------------|------------|-------------------|-----|------|------|
| Spurious Free Dynamic Range Fs = 2.5 GSps Fin = 100 MHz Fs = 2.5 GSps Fin = 620 MHz Fs = 2.5 GSps Fin = 1200 MHz | ISFDRI | 1. 4 | 48 | 57 55 54 | | dBc | (3) |
| Two tone third order intermodulation distortion Fs = 2.5 GSps Fin1 = 490 MHz ; Fin2 = 495 MHz [-7dBFS] | IIMD3I | 4 | | 53 | | dBFS | (3) |
| Dynamic Performance – 1-Channel Mode (Fsampling = 5 GSps , Vin = -1 dBFS) (after calibration) | | | | | | | |
| Effective Number Of Bits Fs = 5 GSps Fin = 100 MHz Fs = 5 GSps Fin = 620 MHz Fs = 5 GSps Fin = 1200 MHz | ENOB | 4 | 7.0 6.8 | 7.3 7.2 6.9 | | Bit | (3) |
| Signal to Noise Ratio Fs = 5 GSps Fin = 100 MHz Fs = 5 GSps Fin = 620 MHz Fs = 5 GSps Fin = 1200 MHz | SNR | 4 | 43 42 | 46 45 43 | | dB | (3) |
| Total Harmonic Distortion (9 Harmonics) Fs = 5 GSps Fin = 100 MHz Fs = 5 GSps Fin = 620 MHz Fs = 5 GSps Fin = 1200 MHz | ITHDI | 4 | 48 49 | 54 54 53 | | dB | (3) |
| Spurious Free Dynamic Range Fs = 5 GSps Fin = 100 MHz Fs = 5 GSps Fin = 620 MHz Fs = 5 GSps Fin = 1200 MHz | ISFDRI | 4 | 48 50 | 57 55 55 | | dBc | (3) |

- Notes:
1. It is recommended to use the ADC in reduced bandwidth mode in order to minimize the noise in the ADC when allowed by the application.
 2. These figures apply in all 4-/2- and 1-channel modes (interleaved and non interleaved modes)
 3. Specified from DC up to 2.5 GHz input signal. Input VSWR is measured on a soldered device. It assumes an external $50\Omega \pm 2\Omega$ controlled impedance line, and a 50Ω driving source impedance ($S_{11} < -30$ dB).
 4. All the figures provided at Fin = 100 MHz and at Fin = 620 MHz are obtained using the ADC in nominal band mode. The one provided at Fin = 1.2 GHz is obtained using the ADC in full band mode.
 5. See section 7.6 for a description of the calibration procedure.

3.5 Transient and Switching Characteristics

Table 3-6. Transient and Switching Characteristics

| Parameter | Symbol | Test Level | Min | Typ | Max | Unit | Note |
|--|--------|------------|-----|------------|------------|--------------|------|
| TRANSIENT PERFORMANCE | | | | | | | |
| Bit Error Rate at 1.25 GSps in Gray mode | BER | 4 | | | 10^{-16} | Error/sample | (1) |
| ADC settling time ($V_{IN} - V_{INN} = 400$ mVpp) in Full BW mode | TS | 4 | | | 4 | Clock cycles | |
| Overshoot recovery time | ORT | 4 | | | 4 | Clock cycles | |
| ADC step response Rise/fall time (10/90%) In Full BW mode In Nominal BW mode | | | | 130 225 | | ps ps | |
| Overshoot | | | | | 2 | % | |
| Ringback | | | | | 2 | % | |

Note: 1. Output error amplitude $< \pm 8$ lsb. $F_s = 1.25$ GSps $T_J = 110^\circ\text{C}$

Table 3-7. Transient and Switching Characteristics

| Parameter | Symbol | Test Level | Min | Typ | Max | Unit | Note |
|---|-----------|------------|-------------------|-----|----------------------|-------------------|------|
| SWITCHING PERFORMANCE AND CHARACTERISTICS | | | | | | | |
| Clock frequency | F_{CLK} | 4 | 400 | | 2500 | MHz | (2) |
| Maximum sampling frequency (for each channel) 4-channel mode 2-channel mode 1-channel mode | F_S | 4 | 200 400 800 | | 1250 2500 5000 | MHz MHz MHz | |
| Minimum clock pulse width (high) | TC1 | 4 | | | 200 | ns | |
| Minimum clock pulse width (low) | TC2 | 4 | | | 200 | ns | |
| Aperture Delay | TA | 4 | | 100 | | ps | |
| ADC Aperture uncertainty | Jitter | 4 | | 200 | | fs rms | |
| Output rise time for DATA (20%–80%) | TR | 4 | | 200 | | ps | (3) |
| Output fall time for DATA (20%–80%) | TF | 4 | | 200 | | ps | (3) |
| Output rise time for DATA READY (20%–80%) | TR | 4 | | 150 | | ps | (3) |
| Output fall time for DATA READY (20%–80%) | TF | 4 | | 150 | | ps | (3) |
| Data output delay | TOD | 4 | | 3 | | ns | (4) |
| Data Ready output delay | TDR | 4 | | 3 | | ns | (4) |
| | TOD-TDRI | 4 | | 60 | 100 | ps | (4) |
| Output Data to Data Ready Propagation Delay | TD1 | 4 | | 430 | | ps | (5) |
| Data Ready to Output Data Propagation Delay | TD2 | 4 | | 370 | | ps | (5) |

Table 3-7. Transient and Switching Characteristics (Continued)

| Parameter | Symbol | Test Level | Min | Typ | Max | Unit | Note |
|----------------------------|--------|------------|------------|-------------------|-----|--------------|------|
| Output Data pipeline delay | | | | | | | |
| 4-channel mode | | | | 7 | | | |
| Port A, B, C, D | | | | | | | |
| 2-channel mode | | | | | | | |
| Port A, C | TPD | 4 | | 8 | | Clock Cycles | |
| Port B, D | | | | 7 | | | |
| 1-channel mode | | | | | | | |
| Port A | | | | 8 | | | |
| Port B | | | | 7 | | | |
| Port C | | | | 7.5 | | | |
| Port D | | | | 6.5 | | | |
| Data Ready Reset delay | TRDR | 4 | | 1 Tclock + 1.8 ns | | | |
| Minimum SYNC pulse width | TSYNC | | 5 x Tclock | | | ns | (6) |
| SYNC setup time | | 4 | | 285 | | ps | |
| SYNC hold time | | 4 | | 240 | | ps | |

- Notes:
1. See Definition of Terms.
 2. The clock frequency lower limit is due to the gain.
 3. $50\Omega//CLOAD = 2$ pF termination (for each single-ended output). Termination load parasitic capacitance derating value: 50 ps/pF (ECL).
 4. TOD and TDR propagation times are defined at package input/outputs. They are given for reference only.
 5. Values for TD1 and TD2 are given for a 2.5 GHz external clock frequency (50% duty cycle). For different sampling rates, apply the following formula: $TD1 = T/2 + (TOD-TDR)$ and $TD2 = T/2 - (TOD-TDR)$, where T= clock period. This places the rising edge (True-False) of the differential Data Ready signal in the middle of the Output Data valid window. This gives maximum setup and hold times for external data acquisition. The difference (TD1- TD2) gives an information if DATA READY is centered on the output data. if data ready is in the middle $TD1 = TD2 = T_{data}/2$.
 6. Tclock external clock period. No transition of SYNC signal is allowed between T1 and T2 (forbidden area). Please refer to [Section 6.2 on page 36](#) and [Figure 6-4 on page 40](#).
 7. This device is recommended for sampling rate beyond 600 Msps (1200 MHz). For application at lower frequencies, please contact e2v hotline for specific application recommendation.
 8. Only applicable in RM = 0 mode. In RM = 1 mode, Data Ready continue during the SYNC, except for a very short period of time (< 2 data cycles) during data ready is reinitialized.

3.6 Explanation of Test Levels

| | |
|---|--|
| 1 | 100% production tested at +25°C ⁽¹⁾ (for “C” Temperature range ⁽²⁾). |
| 2 | 100% production tested at +25°C ⁽¹⁾ , and sample tested at specified temperatures (for “V” Temperature ranges ⁽²⁾). |
| 3 | Sample tested only at specified temperatures |
| 4 | Parameter is guaranteed by design and characterization testing (thermal steady-state conditions at specified temperature). |
| 5 | Parameter is a typical value only guaranteed by design only |
| 6 | 100% production tested over specified temperature range (for “B/Q” Temperature range ⁽²⁾). |

Note: Only MIN and MAX values are guaranteed (typical values are issuing from characterization results).

- Notes:
1. Unless otherwise specified.
 2. If applicable, please refer to Ordering Information.

3.7 Timing Diagrams

For the information on the reset sequence (using SYNCNP, SYNCN signals, please refer to section 7.5).

Figure 3-1. ADC Timing in 4-Channel Mode

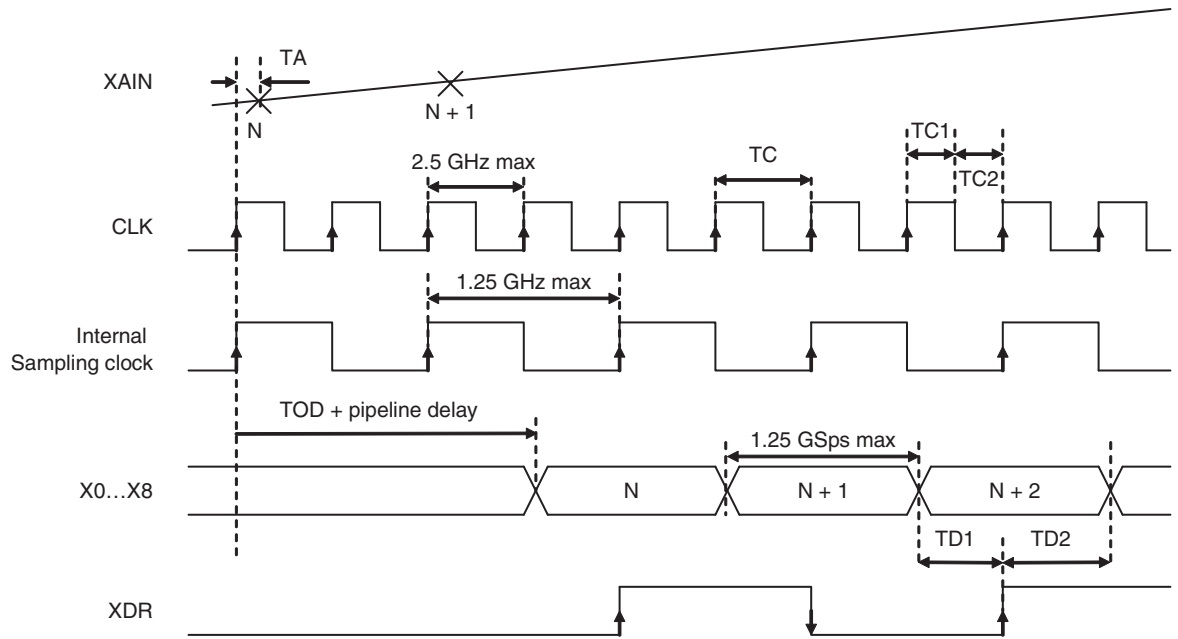

Note: X refers to A, B, C and D.

Figure 3-2. ADC Timing in 2-Channel Mode

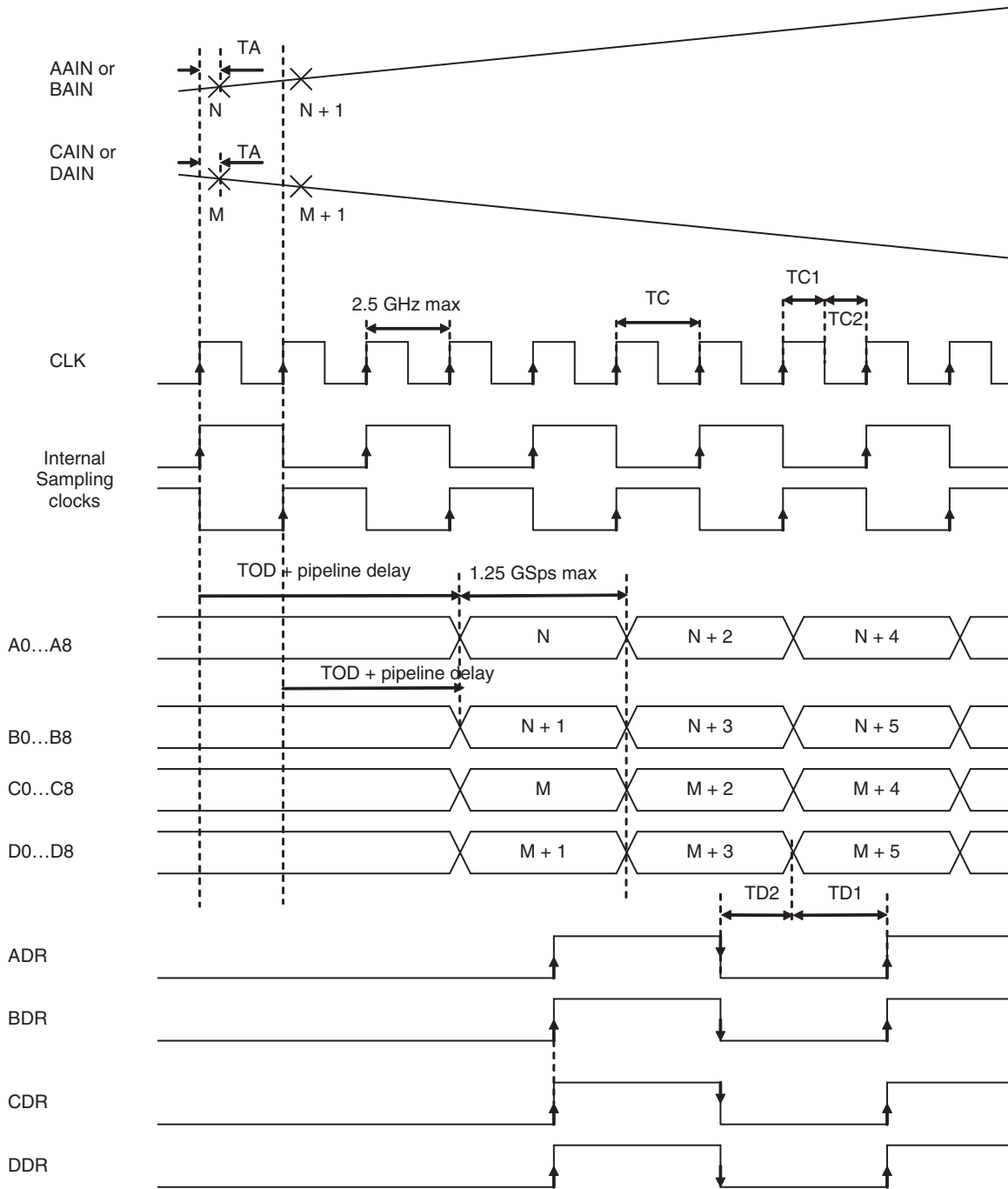

Note: In 2-channel mode, the two analog inputs can be applied on

- AAI, AAIN) and (CAI, CAIN), in which case, the outputs corresponding to (AAI, AAIN) will be on A0...A8 and B0...B8 and the ones corresponding to (CAI, CAIN) on C0...C8 and D0...D8;
- or (AAI, AAIN) and (DAI, DAIN), in which case, the outputs corresponding to (AAI, AAIN) will be on A0...A8 and B0...B8 and the ones corresponding to (DAI, DAIN) on C0...C8 and D0...D8;
- or (BAI, BAIN) and (CAI, CAIN), in which case, the outputs corresponding to (BAI, BAIN) will be on A0...A8 and B0...B8 and the ones corresponding to (CAI, CAIN) on C0...C8 and D0...D8;

- or (BAI, BAIN) and (DAIN, DAIN), in which case, the outputs corresponding to (BAI, BAIN) will be on A0...A8 and B0...B8 and the ones corresponding to (DAI, DAIN) on C0...C8 and D0...D8.

Figure 3-3. ADC Timing in 1-Channel Mode

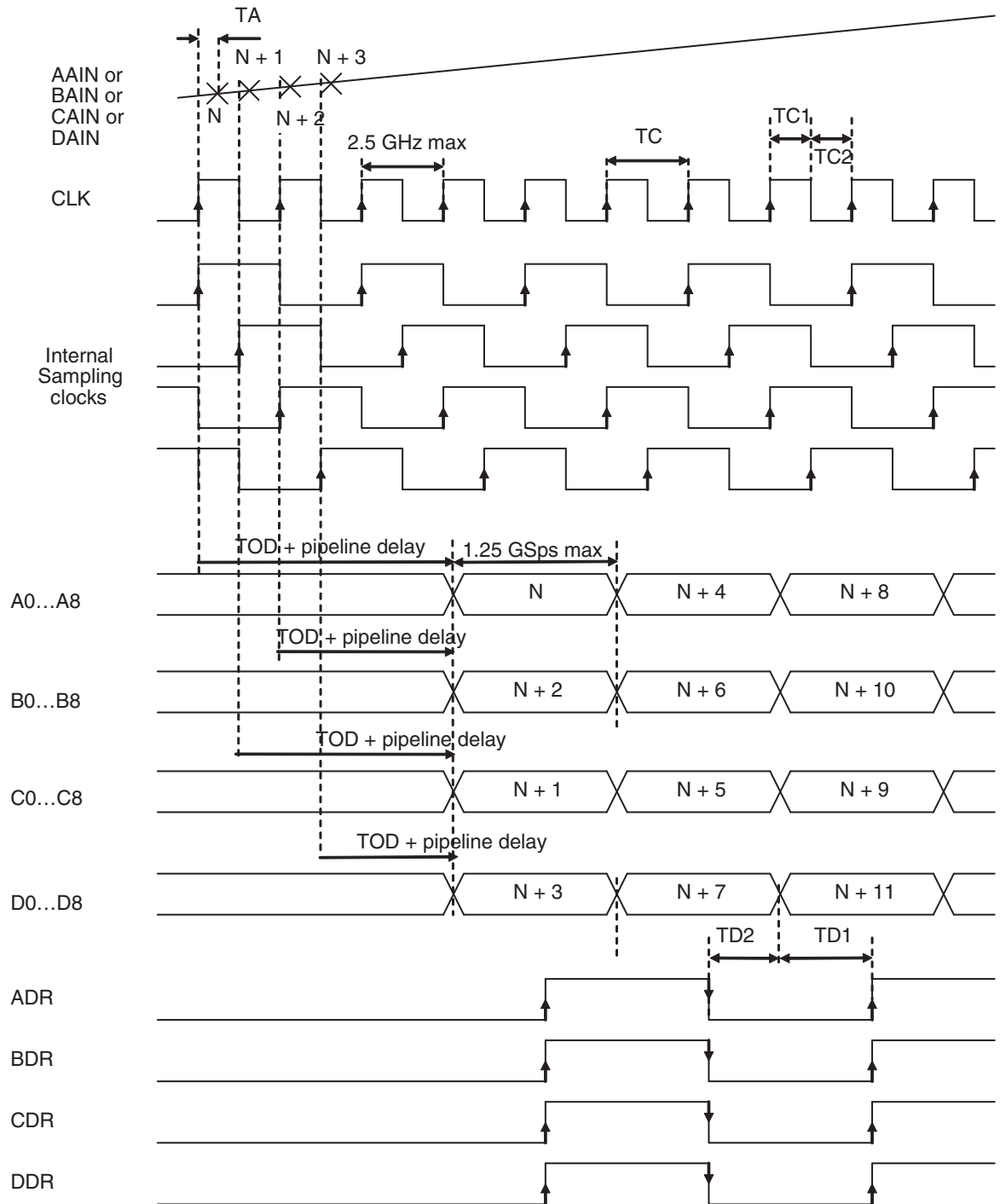

Note: In 1-Channel mode, the analog input can be applied on (AAI, AAIN), (BAI, BAIN), (CAI, CAIN) or (DAI, DAIN). The choice is made via the SPI in the control register.

3.8 Digital Output Coding

Table 3-8. ADC Digital output coding table

| Differential analog input | Voltage level | Digital output | |
|---------------------------|---|--------------------------------------|-------------------------------------|
| | | Binary MSB (bit 8).....LSB(bit 0) | GRAY MSB (bit 8).....LSB (bit 0) |
| +125.5 mV | Top end of full scale + ½ LSB | 1 1 0 0 0 0 0 0 | 1 0 1 0 0 0 0 0 |
| +124.5 mV | Top end of full scale - ½ LSB | 1 0 1 1 1 1 1 1 | 1 1 1 0 0 0 0 0 |
| +0.5 mV | Mid scale + ½ LSB | 1 0 0 0 0 0 0 0 | 1 1 0 0 0 0 0 0 |
| -0.5 mV | Mid scale - ½ LSB | 0 1 1 1 1 1 1 1 | 0 1 0 0 0 0 0 0 |
| -124.5 mV | Bottom end of full scale + ½ LSB | 0 1 0 0 0 0 0 0 | 0 1 1 0 0 0 0 0 |
| -125.5 mV | ¹ Bottom end of full scale - ½ LSB | 0 0 1 1 1 1 1 1 | 0 0 1 0 0 0 0 0 |

Note :

Due to the internal coding of this device and the ±125mV input swing, the midscale is located at binary code 1 0 0 0 0 0 0 0, the code corresponding to maximum input is at code 1 1 0 0 0 0 0 0 and the minimum at 0 1 0 0 0 0 0 0. This is explained in the table below.

If the INRANGE function is required, D7 or a logical combination of D7 and D8 should be used.

Otherwise, D7 can be ignored and D8 is used for the most significant bit of the 8 bit data.

Conversion to standard offset binary coding is relatively straightforward.

In the binary output mode, subtraction of code 00111111 in the FPGA would lead to straight binary coding, and subtraction of code 10000000 in the FPGA will lead to 2's complement coding.

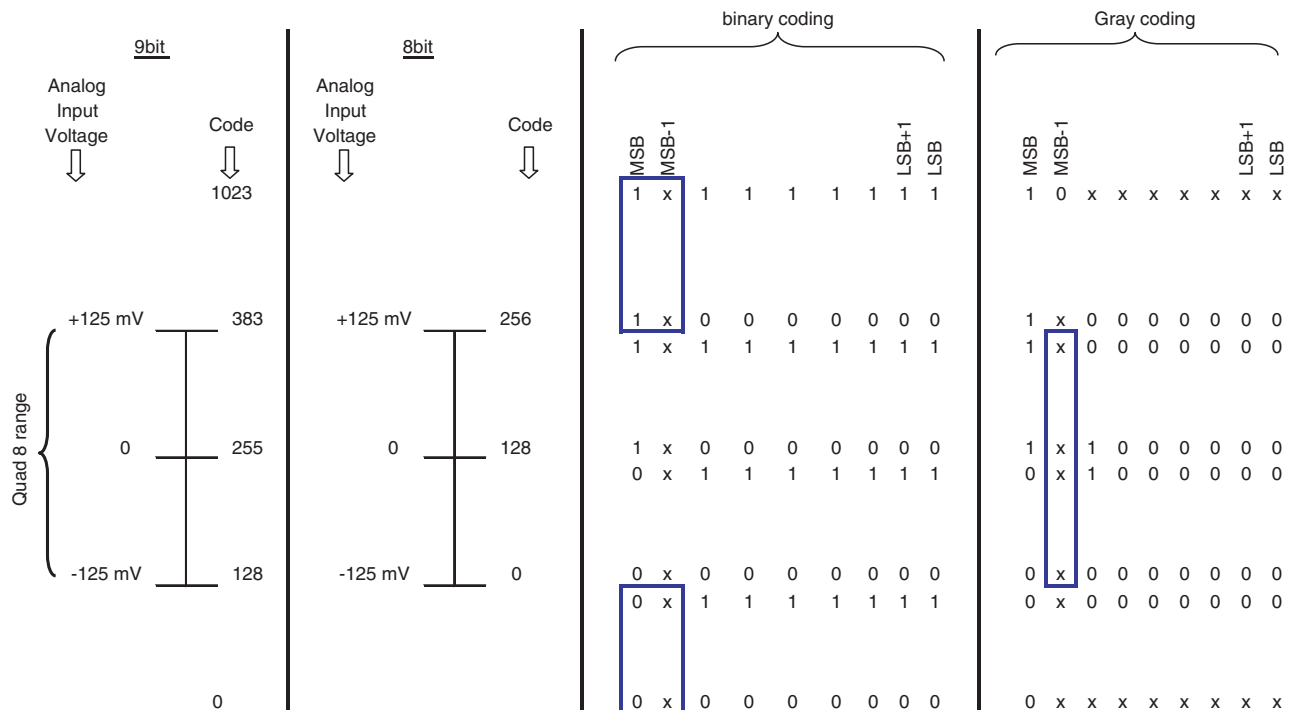

GRAY DECODING

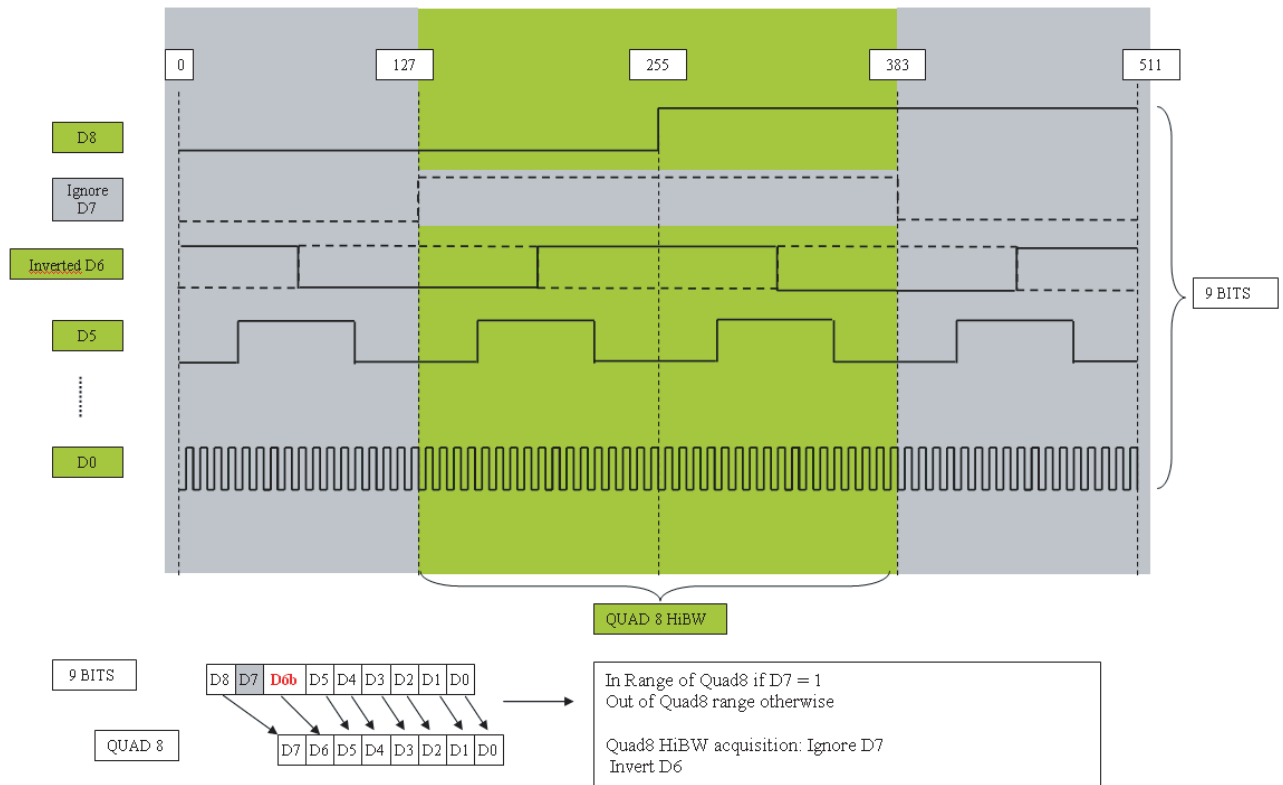

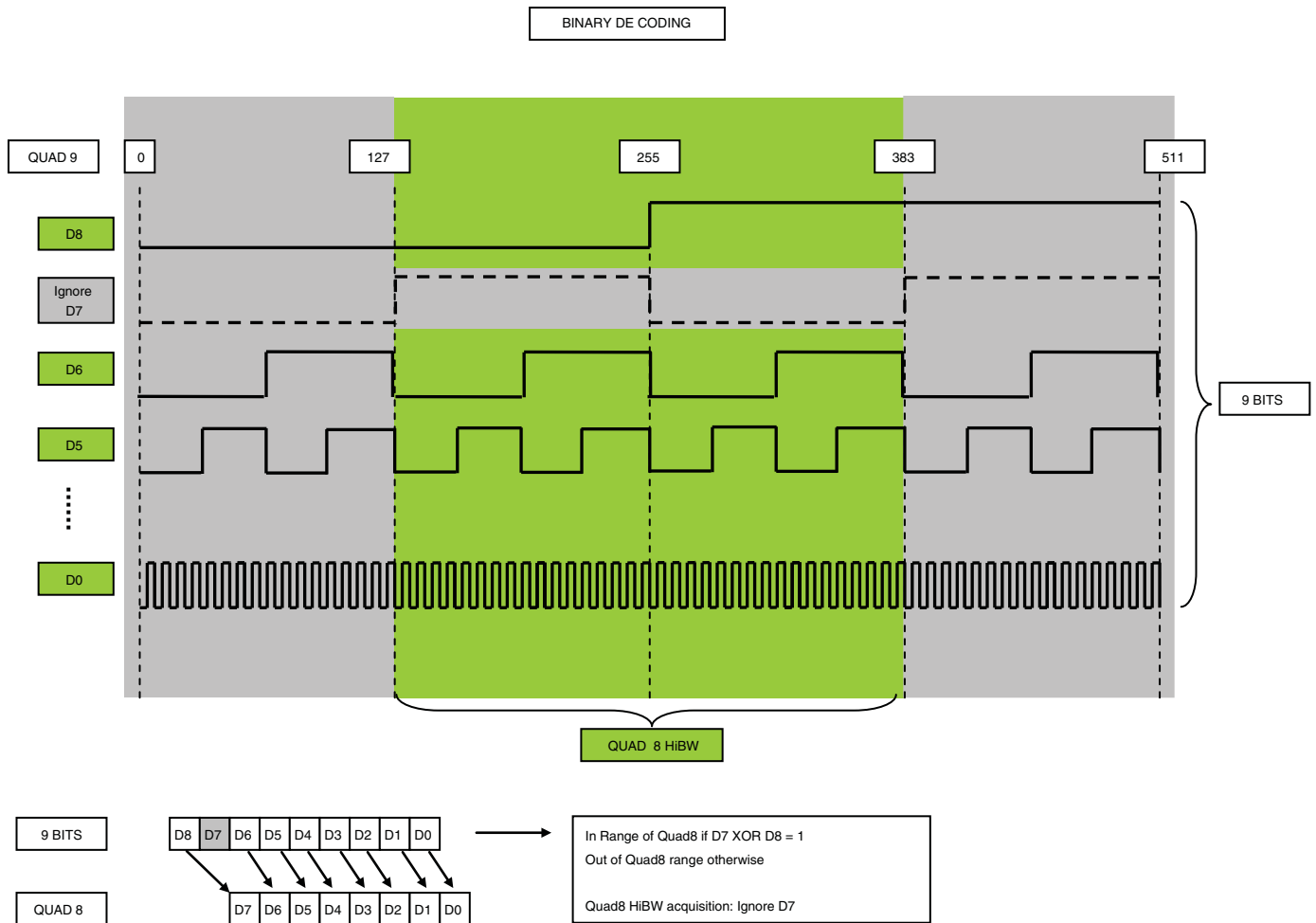

3.9 Definition of Terms

Table 3-9. Definition of Terms

| Abbreviation | Term | Definition |
|--------------|---|---|
| (Fs max) | <i>Maximum Sampling Frequency</i> | Sampling frequency for which ENOB < 6 bits |
| (Fs min) | <i>Minimum Sampling frequency</i> | Sampling frequency for which the ADC Gain has fallen by 0.5 dB with respect to the gain reference value. Performances are not guaranteed below this frequency. |
| (BER) | <i>Bit Error Rate</i> | Probability to exceed a specified error threshold for a sample at maximum specified sampling rate. An error code is a code that differs by more than ±8 LSB from the correct code. |
| (FPBW) | <i>Full power input bandwidth</i> | Analog input frequency at which the fundamental component in the digitally reconstructed output waveform has fallen by 3 dB with respect to its low frequency value (determined by FFT analysis) for input at Full Scale -1 dB (-1 dBFS). |
| (SSBW) | <i>Small Signal Input bandwidth</i> | Analog input frequency at which the fundamental component in the digitally reconstructed output waveform has fallen by 3 dB with respect to its low frequency value (determined by FFT analysis) for input at Full Scale -10 dB (-10 dBFS). |
| (SINAD) | <i>Signal to noise and distortion ratio</i> | Ratio expressed in dB of the RMS signal amplitude, set to 1dB below Full Scale (-1 dBFS), to the RMS sum of all other spectral components, including the harmonics except DC. |

Table 3-9. Definition of Terms (Continued)

| Abbreviation | Term | Definition |
|--------------|--|--|
| (SNR) | <i>Signal to noise ratio</i> | Ratio expressed in dB of the RMS signal amplitude, set to 1dB below Full Scale, to the RMS sum of all other spectral components excluding the nine first harmonics. |
| (THD) | <i>Total harmonic distortion</i> | Ratio expressed in dB of the RMS sum of the first nine harmonic components, to the RMS input signal amplitude, set at 1 dB below full scale. It may be reported in dB (i.e, related to converter –1 dB Full Scale), or in dBc (i.e, related to input signal level). |
| (SFDR) | <i>Spurious free dynamic range</i> | Ratio expressed in dB of the RMS signal amplitude, set at 1dB below Full Scale, to the RMS value of the highest spectral component (peak spurious spectral component). The peak spurious component may or may not be a harmonic. It may be reported in dB (i.e., related to converter –1 dB Full Scale), or in dBc (i.e, related to input signal level). |
| (ENOB) | <i>Effective Number Of Bits</i> | $\text{ENOB} = \frac{\text{SINAD} - 1.76 + 20 \log (A / \text{FS}/2)}{6.02}$ Where A is the actual input amplitude and FS is the full scale range of the ADC under test |
| (DNL) | <i>Differential non linearity</i> | The Differential Non Linearity for an output code i is the difference between the measured step size of code i and the ideal LSB step size. DNL (i) is expressed in LSBs. DNL is the maximum value of all DNL (i). DNL error specification of less than 1 LSB guarantees that there are no missing output codes and that the transfer function is monotonic. |
| (INL) | <i>Integral non linearity</i> | The Integral Non Linearity for an output code i is the difference between the measured input voltage at which the transition occurs and the ideal value of this transition. INL (i) is expressed in LSBs, and is the maximum value of all IINL (i). |
| (TA) | <i>Aperture delay</i> | Delay between the rising edge of the differential clock inputs (CLK, CLKN) (zero crossing point), and the time at which (XAI, XAIN where X = A, B C or D) is sampled. |
| (JITTER) | <i>Aperture uncertainty</i> | Sample to sample variation in aperture delay. The voltage error due to jitter depends on the slew rate of the signal at the sampling point. |
| (TS) | <i>Settling time</i> | Time delay to achieve 0.2% accuracy at the converter output when a 80% Full Scale step function is applied to the differential analog input. |
| (ORT) | <i>Overvoltage recovery time</i> | Time to recover 0.2% accuracy at the output, after a 150% full scale step applied on the input is reduced to midscale. |
| (TOD) | <i>Digital data Output delay</i> | Delay from the rising edge of the differential clock inputs (CLK, CLKN) (zero crossing point) to the next point of change in the differential output data (zero crossing) with specified load. |
| (TDR) | <i>Data ready output delay</i> | Delay from the rising edge of the differential clock inputs (CLK, CLKN) (zero crossing point) to the next point of change in the differential output data (zero crossing) with specified load. |
| (TD1) | <i>Time delay from Data transition to Data Ready</i> | General expression is $\text{TD1} = \text{TC1} + \text{TDR} - \text{TOD}$ with $\text{TC} = \text{TC1} + \text{TC2} = 1$ encoding clock period. |
| (TD2) | <i>Time delay from Data Ready to Data</i> | General expression is $\text{TD2} = \text{TC2} + \text{TDR} - \text{TOD}$ with $\text{TC} = \text{TC1} + \text{TC2} = 1$ encoding clock period. |
| (TC) | <i>Encoding clock period</i> | $\text{TC1} = \text{Minimum clock pulse width (high)}$ $\text{TC} = \text{TC1} + \text{TC2}$ $\text{TC2} = \text{Minimum clock pulse width (low)}$ |
| (TPD) | <i>Pipeline Delay</i> | Number of clock cycles between the sampling edge of an input data and the associated output data being made available, (not taking in account the TOD). |
| (TRDR) | <i>Data Ready reset delay</i> | Delay between the first rising edge of the external clock after reset (SYNCP, SYNCPN) and the reset to digital zero transition of the Data Ready output signal (XDR, where X = A, B, C or D). |
| (TR) | <i>Rise time</i> | Time delay for the output DATA signals to rise from 20% to 80% of delta between low level and high level. |
| (TF) | <i>Fall time</i> | Time delay for the output DATA signals to fall from 20% to 80% of delta between low level and high level. |
| (PSRR) | <i>Power supply rejection ratio</i> | Ratio of input offset variation to a change in power supply voltage. |

Table 3-9. Definition of Terms (Continued)

| Abbreviation | Term | Definition |
|--------------|-----------------------------|--|
| (NRZ) | Non return to zero | When the input signal is larger than the upper bound of the ADC input range, the output code is identical to the maximum code and the Out of Range bit is set to logic one. When the input signal is smaller than the lower bound of the ADC input range, the output code is identical to the minimum code, and the Out of range bit is set to logic one. (It is assumed that the input signal amplitude remains within the absolute maximum ratings). |
| (IMD) | InterModulation Distortion | The two tones intermodulation distortion (IMD) rejection is the ratio of either input tone to the worst third order intermodulation products. |
| (NPR) | Noise Power Ratio | The NPR is measured to characterize the ADC performance in response to broad bandwidth signals. When applying a notch-filtered broadband white-noise signal as the input to the ADC under test, the Noise Power Ratio is defined as the ratio of the average out-of-notch to the average in-notch power spectral density magnitudes for the FFT spectrum of the ADC output sample test. |
| (VSWR) | Voltage Standing Wave Ratio | The VSWR corresponds to the ADC input insertion loss due to input power reflection. For example a VSWR of 1.2 corresponds to a 20dB return loss (ie. 99% power transmitted and 1% reflected). |

4. Characterization Results

Condition :

Typical power supply ($V_{cca} = 3.3V$, $V_{ccd} = 1.8V$, $V_{cco} = 1.8V$)

Ambiant temperature ($V_{diode} = 785\text{ mV} \iff T_j = 59^\circ\text{C}$)

$F_c = 2.5G$, 0 dBm

Figure 4-1. Full Power Input Bandwidth (-1 dBFS input, 1-channel mode, $F_c = 2.5\text{GHz}$, **Full bandwidth setting**)

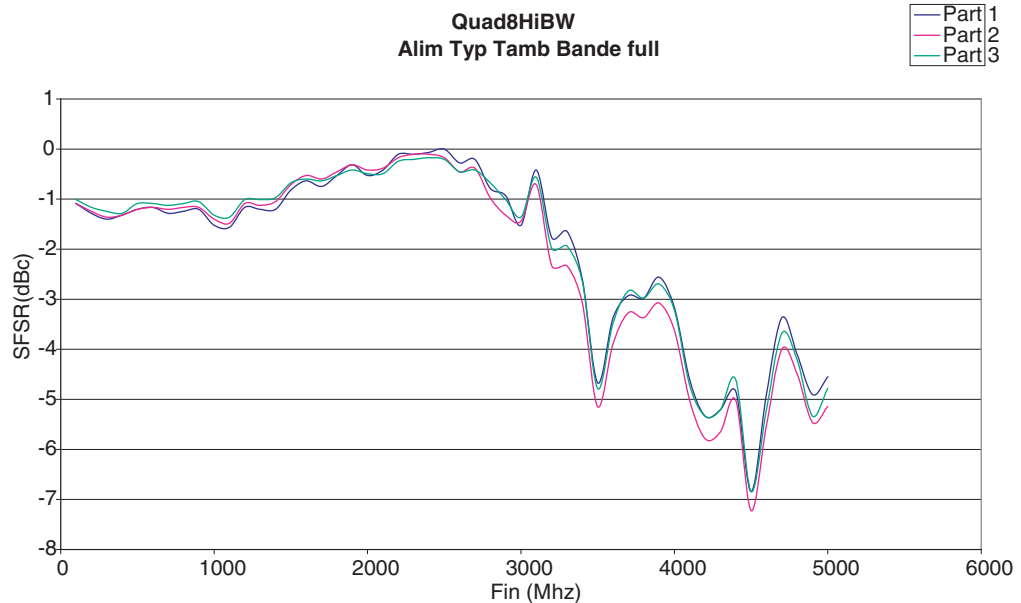

Figure 4-2. Full Power Input Bandwidth (-1 dBFS input, 1-channel mode, $F_c = 2.5\text{GHz}$, Nominal bandwidth setting)

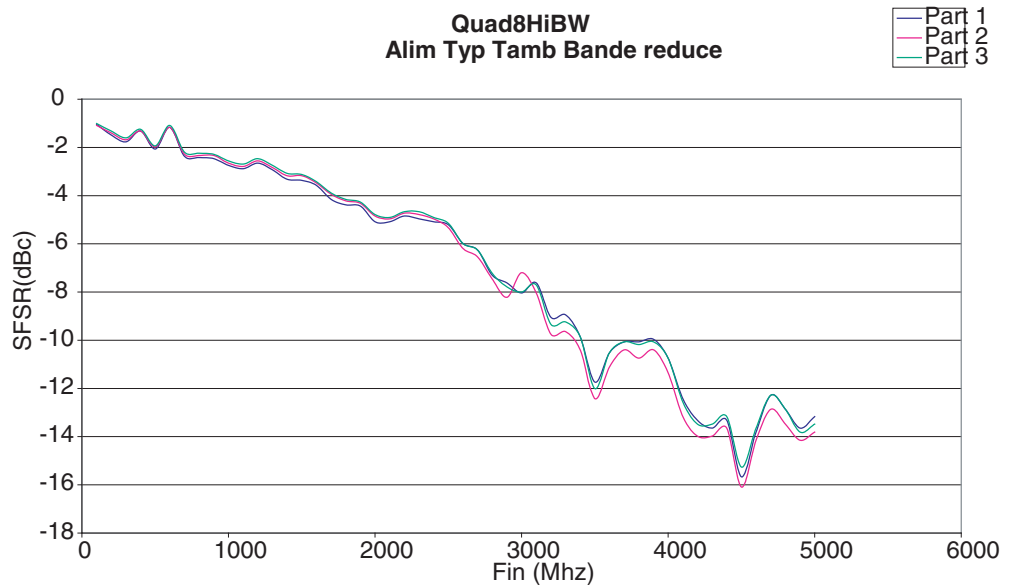

Figure 4-3. ENOB vs Fin

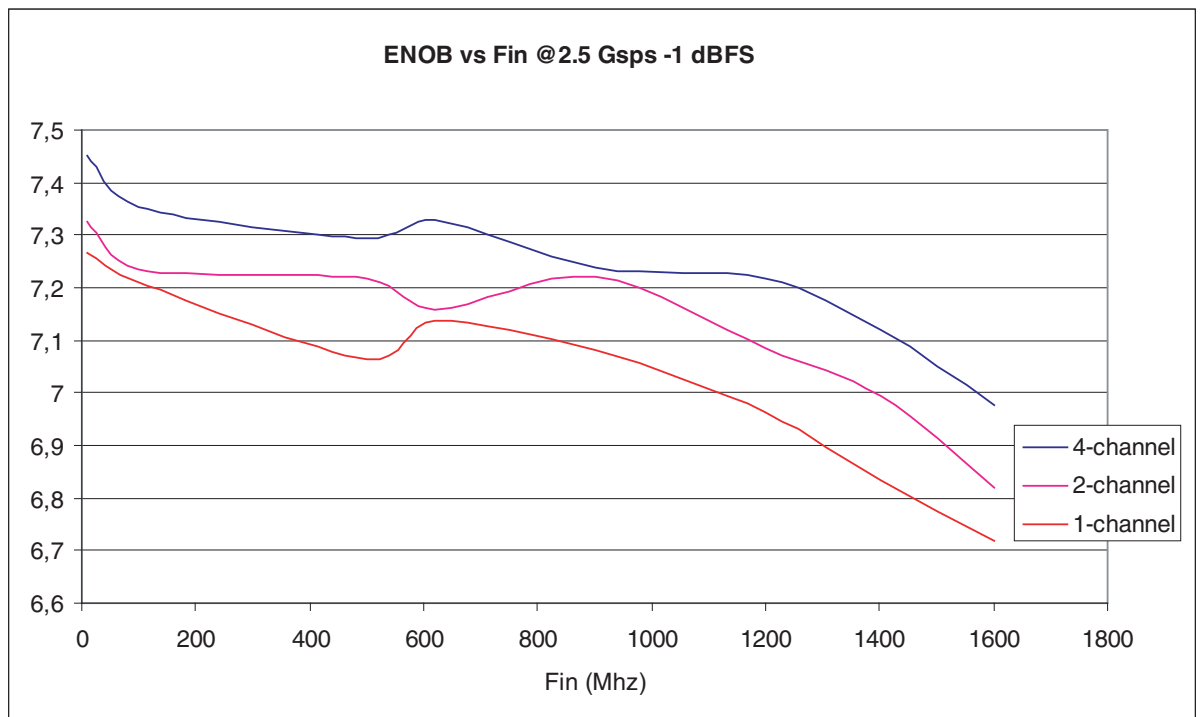

Figure 4-4. SNR vs Fin

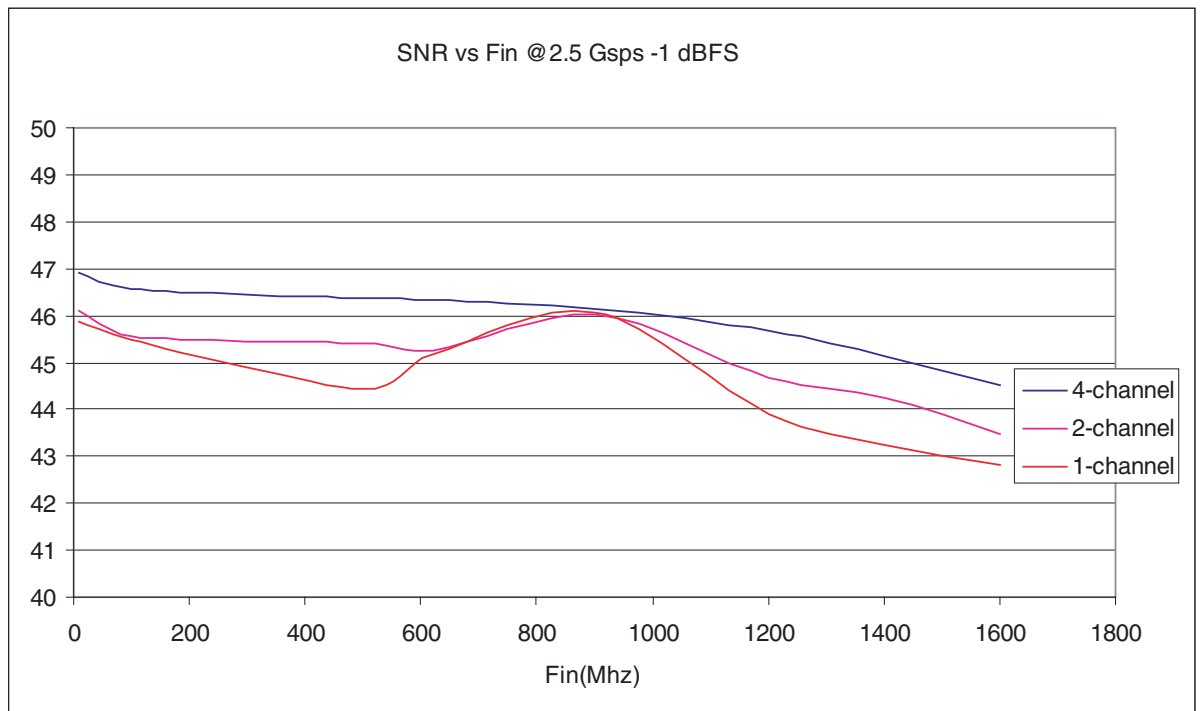

Figure 4-5. THD vs Fin

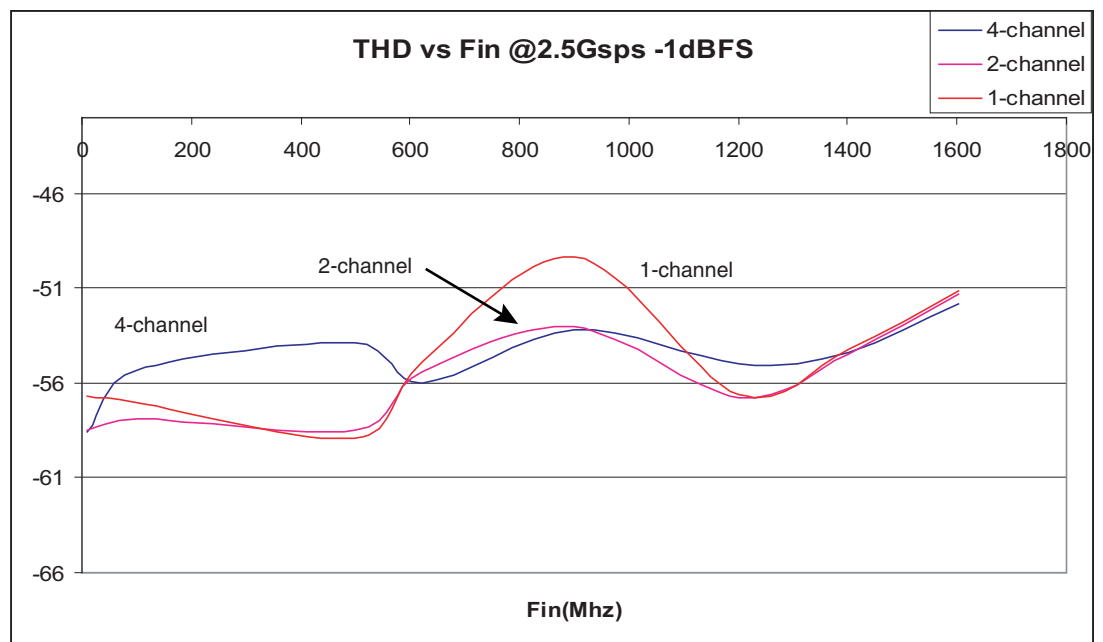
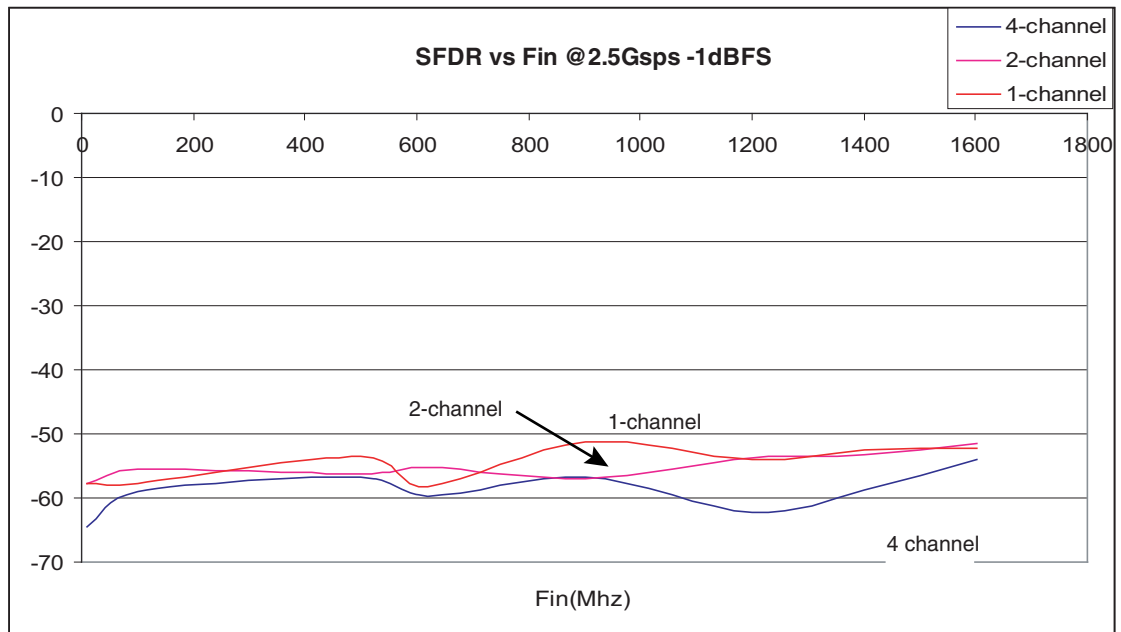



Figure 4-6. SFDR vs Fin



5. Pin Description

5.1 Pinout View (Bottom view)

| | 1 | 2 | 3 | 4 | 5 | 6 | 7 | 8 | 9 | 10 | 11 | 12 | 13 | 14 | 15 | 16 | 17 | 18 | 19 | 20 | 21 | 22 | 23 | 24 | | | | | | | | | | | | | | | | | |
|----|-----|------|------|-----|------|---|-------|------|-----|-----|--------|------|------|-------|-------|------|------|-------|------|------|-----|------|-----|------|------|-----|-----|-----|-----|-----|-----|-----|-----|-----|------|------|-----|------|----|----|---|
| AD | GND | VCC | B7 | B8 | NC | GND | DiodA | NC | GND | NC | SYNCP | CLK | CLKN | scan0 | scan2 | sclk | mosi | Res50 | GND | NC | C8 | C7 | VCC | GND | AD | | | | | | | | | | | | | | | | |
| AC | GND | VCC | B7N | B8N | NC | GND | DiodC | GND | VCC | NC | SYNCPN | GND | GND | scan1 | rstn | csn | miso | Res62 | GND | NC | C8N | C7N | VCC | GND | AC | | | | | | | | | | | | | | | | |
| AB | NC | NC | VCC | GND | VCC | GND | VCC | GND | GND | VCC | VCCD | GND | GND | VCC | VCC | GND | GND | VCC | GND | VCC | GND | VCC | NC | NC | AB | | | | | | | | | | | | | | | | |
| AA | NC | NC | VCC | GND | VCCO | VCC | VCC | GND | GND | VCC | VCCD | GND | GND | VCC | VCC | GND | GND | VCC | VCC | VCCO | GND | VCC | NC | NC | AA | | | | | | | | | | | | | | | | |
| Y | NC | NC | VCCO | GND | GND | VCCO | VCC | GND | GND | VCC | VCCD | GND | GND | VCC | VCC | GND | GND | VCC | VCCO | GND | GND | VCCO | NC | NC | Y | | | | | | | | | | | | | | | | |
| W | NC | NC | VCCO | GND | GND |  | | | | | | | | | | | | | | | | GND | GND | VCCO | NC | NC | W | | | | | | | | | | | | | | |
| V | NC | NC | NC | NC | GND | | | | | | | | | | | | | | | | | GND | NC | NC | NC | NC | V | | | | | | | | | | | | | | |
| U | B6 | B6N | NC | NC | VCCO | | | | | | | | | | | | | | | | | VCCO | NC | NC | C6N | C6 | U | | | | | | | | | | | | | | |
| T | B4 | B4N | B5 | B5N | GND | | | | | | | | | | | | | | | | | GND | C5N | C5 | C4N | C4 | T | | | | | | | | | | | | | | |
| R | B2 | B2N | B3 | B3N | VCC | | | | | | | | | | | | | | | | | VCC | C3N | C3 | C2N | C2 | R | | | | | | | | | | | | | | |
| P | B0 | B0N | B1 | B1N | GND | | | | | | | | | | | | | | | | | GND | C1N | C1 | C0N | C0 | P | | | | | | | | | | | | | | |
| N | BDR | BDRN | NC | NC | VCC | | | | | | | | | | | | | | | | | VCC | NC | NC | CDRN | CDR | N | | | | | | | | | | | | | | |
| M | ADR | ADRN | NC | NC | VCC | | | | | | | | | | | | | | | | | VCC | NC | NC | DDRN | DDR | M | | | | | | | | | | | | | | |
| L | A0 | A0N | A1 | A1N | GND | | | | | | | | | | | | | | | | | GND | D1N | D1 | D0N | D0 | L | | | | | | | | | | | | | | |
| K | A2 | A2N | A3 | A3N | VCC | | | | | | | | | | | | | | | | | VCC | D3N | D3 | D2N | D2 | K | | | | | | | | | | | | | | |
| J | A4 | A4N | A5 | A5N | GND | | | | | | | | | | | | | | | | | GND | D5N | D5 | D4N | D4 | J | | | | | | | | | | | | | | |
| H | A6 | A6N | NC | NC | VCCO | | | | | | | | | | | | | | | | | VCCO | NC | NC | D6N | D6 | H | | | | | | | | | | | | | | |
| G | NC | NC | NC | NC | GND | | | | | | | | | | | | | | | | | GND | NC | NC | NC | NC | G | | | | | | | | | | | | | | |
| F | NC | NC | VCCO | GND | GND | | | | | | | | | | | | | | | | | GND | GND | VCCO | NC | NC | F | | | | | | | | | | | | | | |
| E | NC | NC | VCCO | GND | GND | | | | | | | | | | | | | | | | | VCCO | VCC | GND | GND | GND | GND | GND | GND | GND | GND | GND | GND | VCC | VCCO | GND | GND | VCCO | NC | NC | E |
| D | NC | NC | VCC | GND | VCCO | | | | | | | | | | | | | | | | | VCC | VCC | GND | GND | GND | GND | GND | GND | GND | GND | GND | GND | VCC | VCC | VCCO | GND | VCC | NC | NC | D |
| C | NC | NC | VCC | GND | VCC | VCC | GND | GND | GND | GND | GND | GND | GND | GND | GND | GND | GND | VCC | VCC | GND | VCC | NC | NC | C | | | | | | | | | | | | | | | | | |
| B | GND | VCC | A7N | A8N | NC | GND | GND | GND | GND | GND | GND | MIR6 | MIR5 | MIR4 | GND | GND | GND | GND | GND | NC | D8N | D7N | VCC | GND | B | | | | | | | | | | | | | | | | |
| A | GND | VCC | A7 | A8 | NC | GND | AAI | AAIN | GND | BAI | BAIN | GND | GND | CAI | CAIN | GND | DAI | DAIN | GND | NC | D8 | D7 | VCC | GND | A | | | | | | | | | | | | | | | | |
| | 1 | 2 | 3 | 4 | 5 | 6 | 7 | 8 | 9 | 10 | 11 | 12 | 13 | 14 | 15 | 16 | 17 | 18 | 19 | 20 | 21 | 22 | 23 | 24 | | | | | | | | | | | | | | | | | |

5.2 Pinout Table

Table 5-1. Pinout Table

| Pin Label | Pin number | Description | Direction | Simplified electrical schematics |
|-----------------------|--|--|-----------|----------------------------------|
| Power supplies | | | | |
| GND | A1, A6, A9, A12, A13, A16, A19 A24, B1, B6, B7, B8, B9, B10, B11, B14, B15, B16, B17, B18, B19, B24, C4, C7, C8, C9, C10, C11, C12, C13, C14, C15, C16, C17, C18, C21, D4, D8, D9, D10, D11, D12, D13, D14, D15, D16, D17, D21, E8, E9, E10, E11, E12, E13, E14, E15, E16, E17, J5, J20, L5, L20, P5, P20, T5, T20, Y8, Y9, Y12, Y13, Y16, Y17, AA4, AA8, AA9, AA12, AA13, AA16, AA17, AA21, AB4, AB6, AB8, AB9, AB12, AB13, AB16, AB17, AB19, AB21, AC1, AC6, AC12, AC13, AC19, AC24, AD1, AD6, AD19, AD24 E4, E5, E20, E21, F4, F5, F20, F21, G5, G20, V5, V20, W4, W5, W20, W21, Y4, Y5, Y20, Y21, AC8, AD9 | Ground All ground pin must be connect to a one solid ground plane on evaluation board Common ground (analog + digital) | | |
| VCC | A2, A23, B2, B23, C3, C5, C6, C19, C20, C22, D3, D6, D7, D18, D19, D22, E7, E18, K5, K20, M5, M20, N5, N20, R5, R20, Y7, Y10, Y15, Y18, AA3, AA6, AA7, AA10, AA15, AA18, AA19, AA22, AB3, AB5, AB7, AB10, AB15, AB18, AB20, AB22, AC2, AC23, AD2, AD23 AA14, AB14, Y14, AC9 | Analog + SPI pads power supply (3.3V) | | |
| VCCD | Y11, AB11, AA11 | Digital power supply (1.8V) | | |
| VCCO | D5, D20, E3, E6, E19, E22, F3, F22, H5, H20, U5, U20, W3, W22, Y3, Y6, Y19, Y22, AA5, AA20 | Output power supply (1.8V) | | |
| Clock signal | | | | |
| CLK CLKN | AD12, AD13 | In phase input clock signal and Out of phase input clock signal Master input clock (Sampling clock). This is a differential clock with internal common mode at 1.8V It should be driven in AC coupling Equivalent internal differential 100Ω input resistor | I | |

Table 5-1. Pinout Table (Continued)

| Pin Label | Pin number | Description | Direction | Simplified electrical schematics |
|-----------------------------|------------|---|-----------|----------------------------------|
| Analog input signals | | | | |
| AAI AAIN | A7 A8 | In phase analog input channel A Out of phase analog input channel A | I | |
| BAI BAIN | A10 A11 | In phase analog input channel B Out of phase analog input channel B | I | |
| CAI CAIN | A14 A15 | In phase analog input channel C Out of phase analog input channel C | I | |
| DAI DAIN | A17 A18 | In phase analog input channel D Out of phase analog input channel D | I | |
| XAI XAIN | | <p>In phase analog input channel X (X = A, B, C or D) Out of phase analog input channel X</p> <p>Analog input (differential) with internal common mode at 1.6V (CMIRefAB/CD signal) It should be driven in AC coupling or DC coupling with CMIREFAB/CD output signal</p> <p>XAI input is sampled and converted (9 bit) on each positive transition on the CLK Input</p> <p>Equivalent internal differential 100Ω input resistor</p> | I | |

Table 5-1. Pinout Table (Continued)

| Pin Label | Pin number | Description | Direction | Simplified electrical schematics |
|---|--|--|-----------|---|
| Digital output signals | | | | |
| A0, A0N A1, A1N A2, A2N A3, A3N A4, A4N A5, A5N A6, A6N A7, A7N A8, A8N | L1, L2 L3, L4 K1, K2 K3, K4 J1, J2 J3, J4 H1, H2 A3, B3 A4, B4 | <p>Channel A in phase output data*</p> <p>A0 is the LSB, A8 is the MSB</p> <p>Channel A out of phase output data</p> <p>A0N is the LSB, A8N is the MSB</p> <p>This differential digital output data is transmitted at CLK/2 clock rate (1.25 Gbps max). Each of these outputs should always be terminated by 100Ω differential resistor placed as close as possible to differential receiver</p> <p>Differential LVDS signal</p> | O | <p>The schematic shows a differential LVDS driver circuit. It features a current source of 820 μA connected to a 100Ω resistor. The circuit includes several 100Ω resistors and 1.8kΩ resistors connected to VPLSD (2.5V ± 5%) and SUBST (5V) rails. The output is a differential signal labeled 'OUT' and 'OUTN'.</p> |
| ADR ADRN | M1 M2 | <p>Channel A Output clock (Data Ready clock in DDR mode)</p> <p>This differential output clock is used to latch the output data on rising and falling edge.</p> <p>This differential digital output clock is at CLK/4 clock frequency (625MHz max).</p> <p>should always be terminated by 100Ω differential resistor placed as close as possible to differential receiver</p> <p>Differential LVDS signal</p> | O | <p>The schematic shows a differential LVDS driver circuit for the clock signal. It features a current source of 820 μA connected to a 100Ω resistor. The circuit includes several 100Ω resistors and 1.8kΩ resistors connected to VPLSD (2.5V ± 5%) and SUBST (5V) rails. The output is a differential signal labeled 'OUT' and 'OUTN'.</p> |

Table 5-1. Pinout Table (Continued)

| Pin Label | Pin number | Description | Direction | Simplified electrical schematics |
|--|--|--|-----------|----------------------------------|
| B0, B0N B1, B1N B2, B2N B3, B3N- B4, B4N B5, B5N B6, B6N B7, B7N B8, B8N | P1, P2 P3, P4 R1, R2 R3, R4 T1, T2 T3, T4 U1, U2 AD3, AC3 AD4 AC4 | Channel B in phase output data B0 is the LSB, B8 is the MSB B0N is the LSB, B8N is the MSB This differential digital output data is transmitted at CLK/2 clock rate (1.25Gbps max). Each of these outputs should always be terminated by 100Ω differential resistor place as close as possible to differential receiver Differential LVDS signal | O | |
| BDR BDRN | N1 N2 | Channel B Output clock This differential output clock is used to latch the output data on rising and falling edge. This differential digital output clock is at CLK/4 clock frequency (625MHz max). should always be terminated by 100Ω differential resistor placed as close as possible to differential receiver Differential LVDS signal | O | |
| C0, C0N C1, C1N C2, C2N C3, C3N C4, C4N C5, C5N C6, C6N C7, C7N C8, C8N | P24, P23 P22, P21 R24, R23 R22, R21 T24, T23 T22, T21 U24, U23 AD22, AC22 AD21, AC21 | Channel C in phase output data C0 is the LSB, C8 is the MSB C0N is the LSB, C8N is the MSB This differential digital output data is transmitted at CLK/2 clock rate (1.25 Gbps max). Each of these outputs should always be terminated by 100Ω differential resistor placed as close as possible to differential receiver Differential LVDS signal | O | |

Table 5-1. Pinout Table (Continued)

| Pin Label | Pin number | Description | Direction | Simplified electrical schematics |
|---|--|---|-----------|----------------------------------|
| CDR CDRN | N24 N23 | <p>Channel C Output clock</p> <p>This differential output clock is used to latch the output data on rising and falling edge.</p> <p>This differential digital output clock is at CLK/4 clock frequency (625MHz max).</p> <p>should always be terminated by 100Ω differential resistor placed as close as possible to differential receiver</p> <p>Differential LVDS signal</p> | O | |
| D0, D0N D1, D1N D2, D2N D3, D3N D4, D4N D5, D5N D6, D6N D7, D7N D8, D8N | L24, L23 L22, L21 K24, K23 K22, K21 J24, J23 J22, J21 H24, H23 A22, B22 A21, B21 | <p>Channel D in phase output data</p> <p>D0 is the LSB, D8 is the MSB</p> <p>D0N is the LSB, D8N is the MSB</p> <p>This differential digital output data is transmitted at CLK/2 clock rate (1.25 Gbps max). Each of these outputs should always be terminated by 100Ω differential resistor placed as close as possible to differential receiver</p> <p>Differential LVDS signal</p> | O | |
| DDR DDRN | M24 M23 | <p>Channel D Output clock</p> <p>This differential output clock is used to latch the output data on rising and falling edge.</p> <p>This differential digital output clock is at CLK/4 clock frequency (625MHz max).</p> <p>should always be terminated by 100Ω differential resistor placed as close as possible to differential receiver</p> <p>Differential LVDS signal</p> | O | |

Table 5-1. Pinout Table (Continued)

| Pin Label | Pin number | Description | Direction | Simplified electrical schematics |
|-------------------------|----------------------|---|-----------|---|
| SPI signals | | | | |
| csn | AC16 | SPI signal (3.3V CMOS) Input Chip Select signal (Active low) When this signal is active low, sclk is used to clock data present on MOSI or MISO signal Refer to section 6.6 for more information | I |  <p>Non-inverting CMOS Schmitt-trigger input</p> |
| sclk | AD16 | SPI signal (3.3V CMOS) Input SPI serial Clock Serial data is shifted into and out SPI synchronously to this signal on positive transition of sclk Refer to section 6.6 for more information | I | |
| mosi | AD17 | SPI signal (3.3V CMOS) Data SPI Input signal (Master Out Slave In) Serial data input is shifted into SPI while sldn is active low Refer to section 6.6 for more information | I | |
| rstn | AC15 | SPI signal (3.3V CMOS) Input Digital asynchronous SPI reset (Active low) This signal allows to reset the internal value of SPI to their default value Refer to section 6.6 for more information | I | |
| miso | AC17 | SPI signal (3.3V CMOS) Data output SPI signal (Master In Slave Out) Serial data output is shifted out SPI while sldn is active low. MISO should be pulled up to V _{CC} using 1K – 3K3 resistor MISO not tristated when inactive Refer to section 6.6 for more information | O |  <p>Output Pad 80Ω 4 mA</p> |
| Other signals | | | | |
| scan0 scan1 scan2 | AD14 AC14 AD15 | Scan mode signals (Used for internal purpose) Pull up to V _{CC} | | |

Table 5-1. Pinout Table (Continued)

| Pin Label | Pin number | Description | Direction | Simplified electrical schematics |
|----------------------|--------------|--|-----------|----------------------------------|
| SYNCP SYNCP | AC11 AD11 | Differential Input Synchronization signal (LVDS) Active high signal This signal is used to synchronize external ADC, Refer to section 7.5 for more information Equivalent internal differential 100Ω input resistor | I | |
| Res50 Res62 | AD18 AC18 | 50Ω and 62Ω reference resistor input Refer to section 6.5 for more information | | |
| CMIRefAB CMIRefCD | B12 B13 | Output voltage reference for Channel A-B and C-D Input Common mode In AC coupling operation this output could be left floating (not used) In DC coupling operation, this pins provides an output voltage witch is the common mode voltage for the analog input signal and should be used to set the common mode voltage of the input driving buffer. CMIRefAB for A and B channel CMIRefCD for C and D channel | O | |

Table 5-1. Pinout Table (Continued)

| Pin Label | Pin number | Description | Direction | Simplified electrical schematics |
|----------------|---|--|------------|----------------------------------|
| DiodA DiodC | AD7 AC7 | Input Temperature diode Anode Input Temperature diode Cathode Refer to section 6.4 for more information | I O | |
| NC | A5, A20, B5, B20, C1, C2, C23, C24, D1, D2, D23, D24, E1, E2, E23, E24, F1, F2, F23, F24, G1, G2, G3, G4, G21, G22, G23, G24, H3, H4, H21, H22, M3, M4, M22, M21, N3, N4, N22, N21, U3, U4, U21, U22, V1, V2, V3, V4, V21, V22, V23, V24, W1, W2, W23, W24, Y1, Y2, Y23, Y24, AA1, AA2, AA23, AA24, AB1, AB2, AB23, AB24, AC5, AC10, AC20, AD8, AD5, AD10, AD20 | Reserved pins DO NOT CONNECT | | |

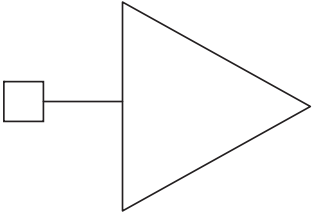
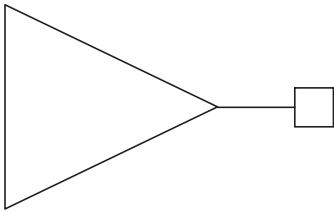
6. Theory of Operation

6.1 Overview

Table 6-1. Functional Description

| Name | Function | | |
|----------------------|--|-----------|---|
| V _{CC} | 3.3V Power Supply (analog core + SPI Pads) | | |
| V _{CCO} | 1.8V Output Power Supply | | |
| V _{CCD} | 1.8V Digital Power Supply | | |
| GND | Ground | | |
| AAI, AAIN | Channel A Differential Analog Input | | |
| BAI, BAIN | Channel B Differential Analog Input | | |
| CAI, CAIN | Channel C Differential Analog Input | | |
| DAI, DAIN | Channel D Differential Analog Input | | |
| CLK, CLKN | Differential Clock Input | | |
| [A0:A8] [A0N:A8N] | Channel A Differential Output Data | | |
| [B0:B8] [B0N:B8N] | Channel B Differential Output Data | | |
| [C0:C8] [C0N:C8N] | Channel C Differential Output Data | | |
| [D0:D8] [D0N:D8N] | Channel D Differential Output Data | | |
| ADR, ADRN | Channel A Data Ready Differential Output Clock | | |
| BDR, BDRN | Channel B Data Ready Differential Output Clock | RSTN | SPI Asynchronous Reset Input (Active Low) |
| CDR, CDRN | Channel C Data Ready Differential Output Clock | SCAN[2:0] | Digital Scan Mode Signals |
| DDR, DDRN | Channel D Data Ready Differential Output Clock | DIOD1A | Diode Anode Input for die junction temperature monitoring |
| SYNCP, SYNCN | Synchronization of Data Ready (LVDS input) | DIOD1C | Diode Cathode Input for die junction temperature monitoring |
| SCLK | SPI Input Clock | Res50 | 50Ω reference input resistor |

Table 6-1. Functional Description (Continued)

| Name | Function | | |
|------|--|----------|---|
| MISO | SPI Output Data (Master In Slave Out) MISO should be pulled up to Vcc using 1K – 3K3 resistor Note: MISO not tristated when inactive | Res62 | 62Ω reference input resistor |
| MOSI | SPI input Data (Master Out Slave In) | CMIRefAB | Output voltage Reference for Input common Mode reference Channels A and B |
| CSN | Chip Select Input (Active Low) | CMIRefCD | Output voltage Reference for Input common Mode reference Channels C and D |

6.2 ADC Synchronization Signal (SYNCP, SYNCN)

The SYNCP, SYNCN signal has LVDS electrical characteristics. It is active high and should last at least TSYNC clock cycles to work properly.

This signal is used for internal synchronization. Its behavior is selectable via SPI (RM and SYNC registers).

The SYNC register allows for expanding the internal SYNC signal in order to align different chips for multi-channel applications. This additional time can be programmed from 0 to 15 input clock cycles.

The RM bit (Control register) describes the behavior of the SYNC signal:

- If RM is set to LOW, internal clocks are locked while SYNC is active
- If RM is set to HIGH, internal clocks will continue toggling during SYNC and will be resynchronized only at falling edge of SYNC. (this is to prevent to unlock PLL on data).

The SYNCP, SYNCN pulse is mandatory whenever the following ADC modes are changed: Standby, DMUX mode, Test mode (2), Channel mode. For all other ADC modes there is no need to perform a SYNCP, SYNCN pulse.

Examples:

The SYNCP, SYNCN pulse is mandatory after power up or power configuration: when switching the ADC from standby (full or partial) to normal mode.

The SYNCP, SYNCN pulse is mandatory after channel mode configuration: when switching the ADC from four-channel mode to one-channel mode.

The SYNCP, SYNCN pulse is mandatory for test sequence: when switching the ADC from normal running mode to ramp or flashing mode (see in normal mode test resources are powered down and need to be reinitialized after entering in test mode) but it is no needed when the ADC is switched from test mode (ramp or flashing), to normal running mode.

Notes:

1. In decimation mode, the SYNCP, SYNCN signal also resets the clock dividers for decimation, therefore data outputs are not refreshed or may be corrupted when SYNC, SYNCN is active.
2. SYNCP, SYNCN pulse is not needed from Test mode to Normal mode. For details regarding synchronization of multiple converters see Application Note "AN1083 B".
3. To avoid metastability problems on internal SYNC signals, it is mandatory to respect SYNC T1 and T2 time (see Table 3-7), as no transition of the SYNC signal is allowed between T1 and T2 time. Please refer to [Figure 6-4 on page 40](#).

Figure 6-1. ADC SYNC Timing in Four-channel Mode, RM = 0, SYNC Register y = 3 (Tunable 0 to 15 Cycles)

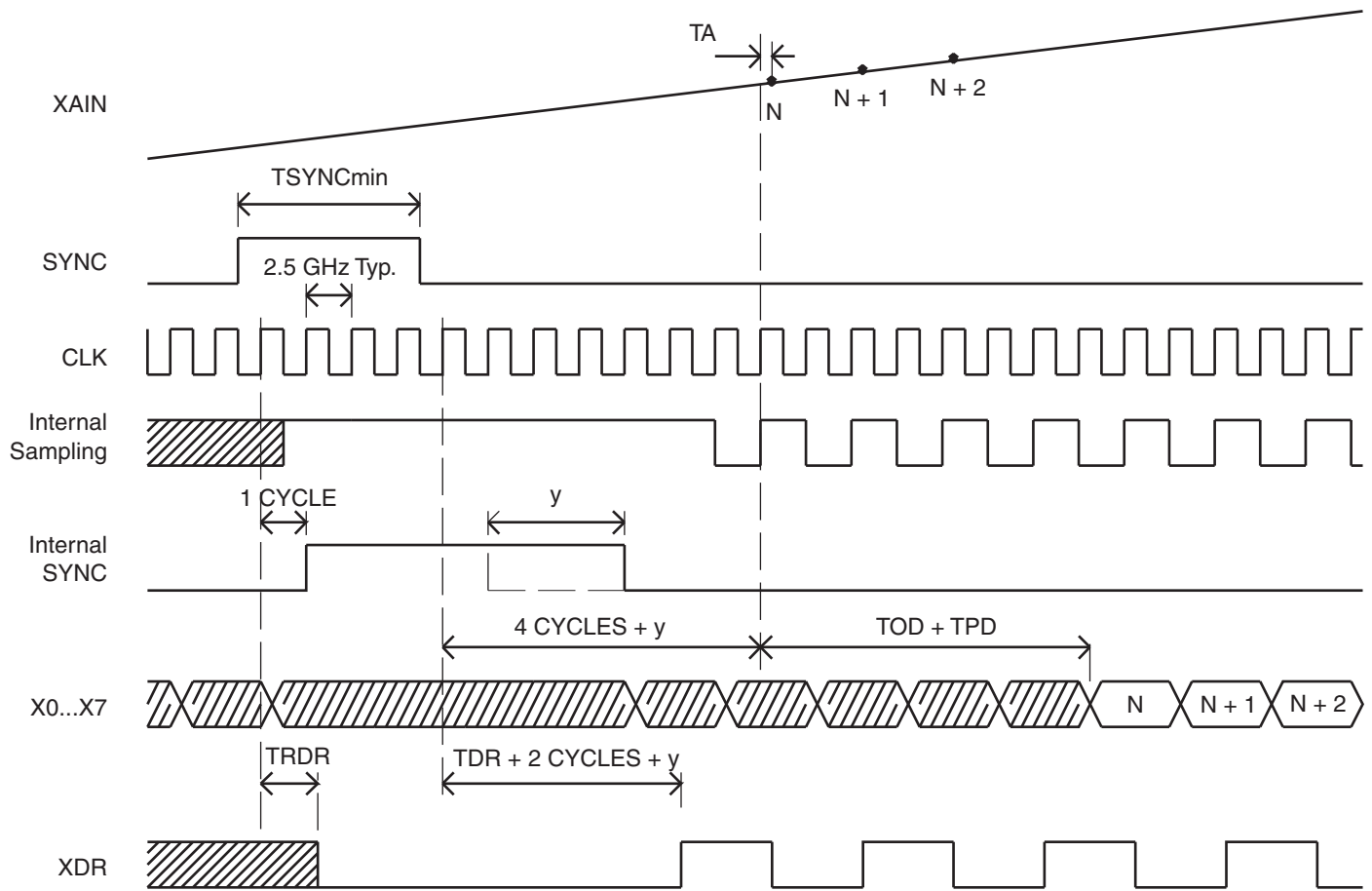

- Notes: 1. When the SYN signal is released (inactive), the ADC restarts with the first rising edge of CLK clock. This means that the Data Ready restarts after a fixed 2 clock cycle delay + a pure delay TDR (normal operation). **This restart can be extended thanks to SPI feature.** You can add y extra clock cycles (external clock) before starting up of the Data ready signal after reset (SYNC, SYNCN). The propagation delay becomes:
 Data Ready restart after a after a fixed 3 clock cycle delay + pure delay TDR + **y extra clock cycles.**
 y is the value of SYNC register (address 0x06). Default value is 0 and maximum value is 15 CLK clock cycles.

Figure 6-2. ADC SYNC Timing in Four-channel Mode, RM = 1, SYNC Register y = 3 (Tunable 0 to 15 Cycles)

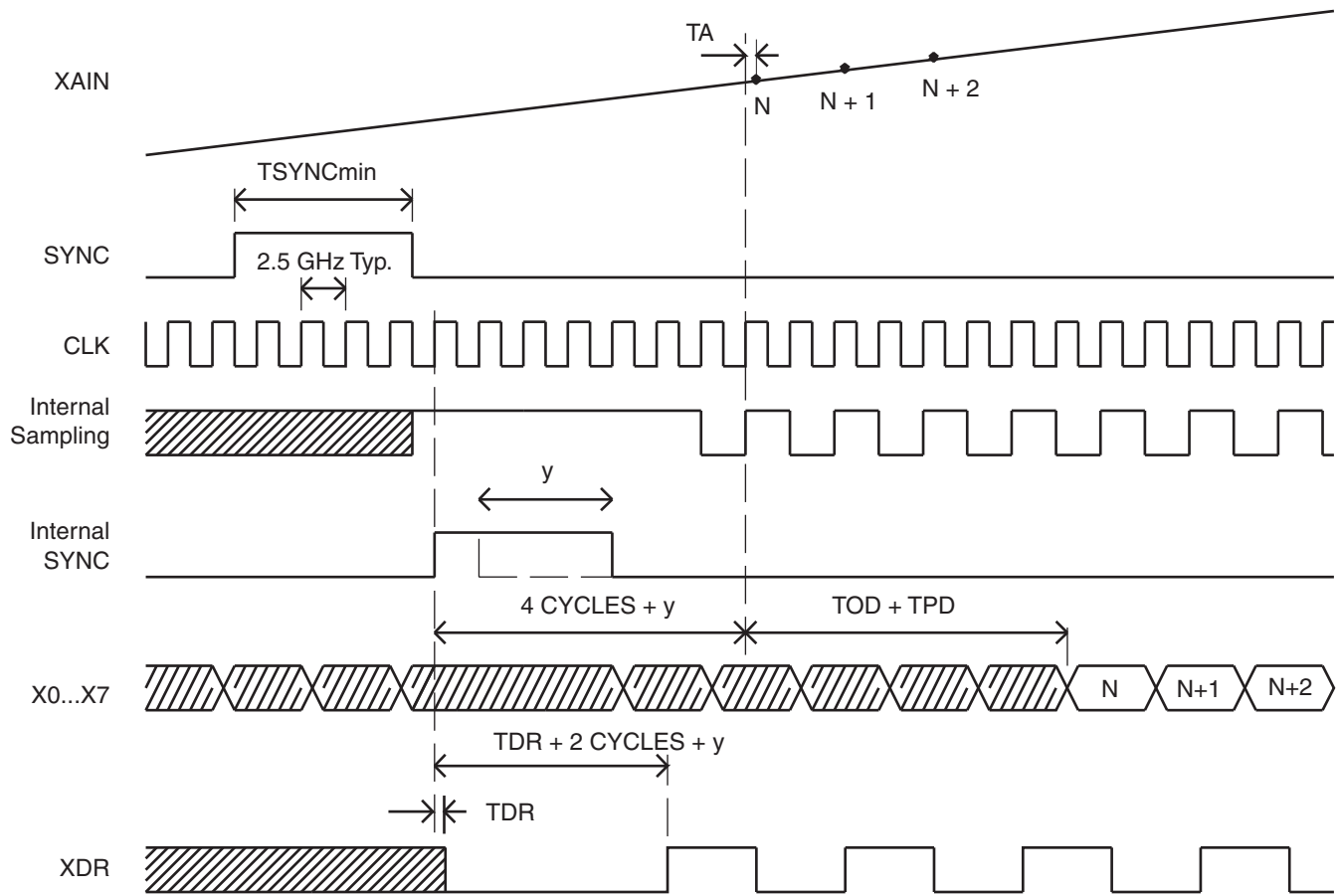
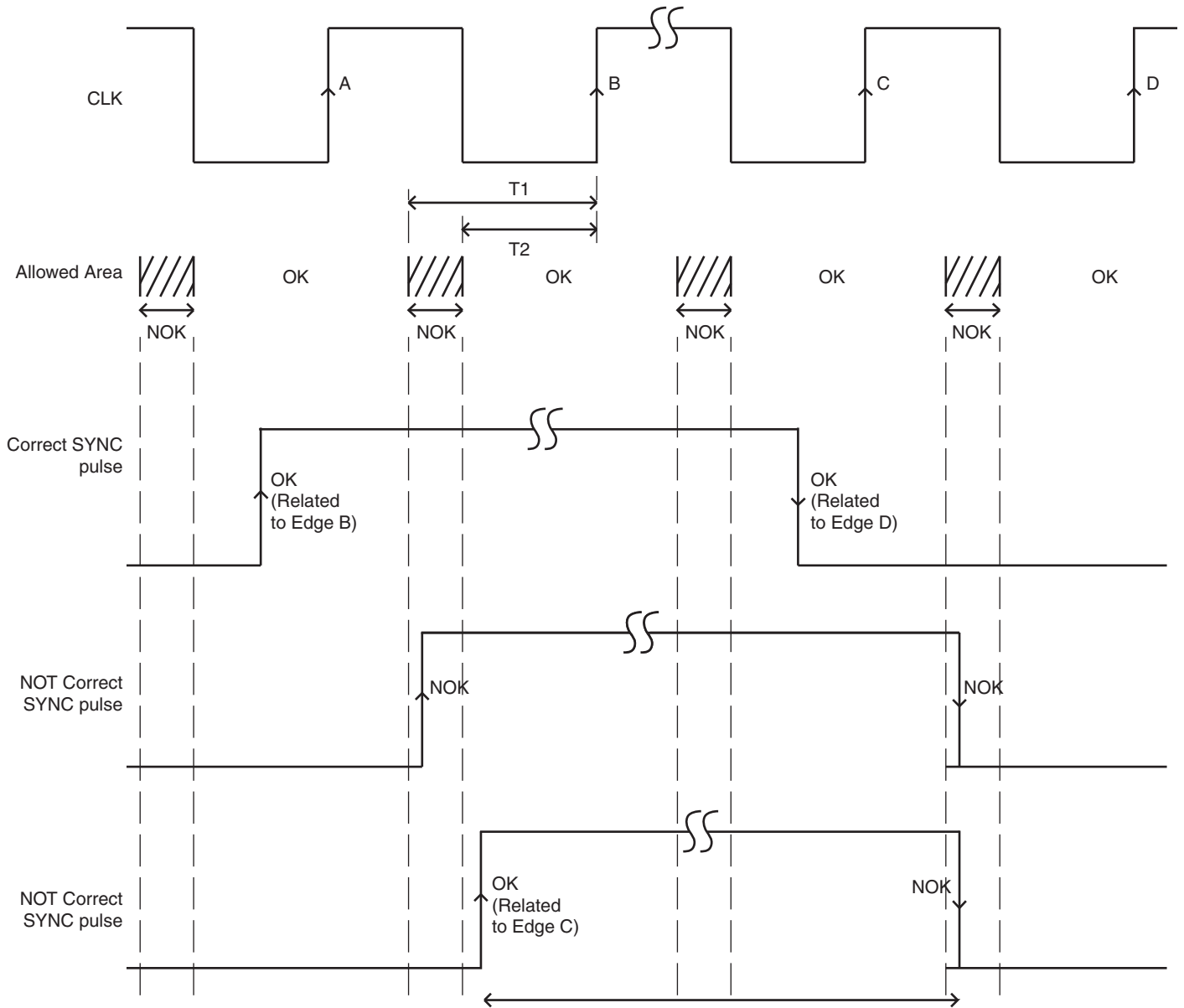

Figure 6-3. ADC SYNC Timing Condition



6.3 Digital Scan Mode (SCAN[2:0])

These signals allow performing a scan of the digital part of the ADC.

Reserved USE ONLY.

User: Pull up to V_{CC} .

6.4 Die Junction Temperature Monitoring Diode

DIODEA, DIODEC: two pins are provided so that the diode can be probed using standard temperature sensors.

For the measurement of die junction temperature, you could use ADM1032 from On Semiconductor http://www.onsemi.com/pub_link/Collateral/ADM1032-D.PDF

Figure 6-4. Junction Temperature Monitoring Diode System

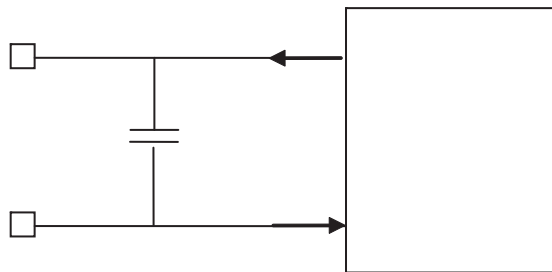

Note: If the diode function is not used, DIODA and DIODC can be left unconnected (open).

6.5 Res50 and Res62

The Res50 and Res62 correspond to the input of internal 50Ω and 62Ω reference resistors that are used to check the process deviation.

The idea is to inject a current into pin Res50, measure the voltage across Res50 and nearest ground pin (AD19), same process should be used for Res62.

You then have 2 equations with 2 unknown parameters:

$$\text{Res50} = k \times 50 + e1$$

$$\text{Res62} = k \times 62 + e2$$

- where k is due to the process
- where e1 and e2 are due to the measurement errors.

Assuming that $e1 = e2$ since the same process is used to measure both Res50 and Res62 in the same conditions, you can obtain the k factor by working out this equation, which helps you determine if you need to compensate for the process by increasing or decreasing the resistors value (TRIMMER register at address 0x13) of the input resistors (there are two 50Ω resistors per analog input channel).

Note: If the Res50, Res62 function is not used, Res50 and Res62 can be left unconnected (open).

The two pins Res62 and Res50 are for checking the actual centering of the process.

The two point measurement reduces measurement errors. Since the current circulating through ground in normal operation is about 1.25A, a shift of 10mV on the pins RES62 and RES50 is consistent.

One way to get rid of the shift in IR-drop to ground when measuring RES62 of RES50 at actual operational temperature is to use a two step measurement (circuit being normally powered):

1. measure the voltage of these two pins regarding board ground without injecting any current (yields V_{res62_0mA} and V_{res50_0mA} , which should be at the same value: the actual ground level in die)
2. measure the voltage of these two pins regarding board ground injecting sequentially 2 mA in these pins this yields V_{res62_2mA} and V_{res50_2mA} .

Subtracting the actual resistance would then yield $R_{62} = (V_{res62_2mA} - V_{res62_0mA})/2mA$ and $measR_{50} = (V_{res50_2mA} - V_{res50_0mA})/2mA$. This should minimize the systematic error .

Note: when computing the systematic error an accumulated misreading of $\pm 1\Omega$ on $measR_{50}$ and $measR_{62}$ can lead to a fluctuation of $\pm 1\Omega$ in the estimation of the systematic error e (for obvious physical reasons e cannot be negative, because it represents parasitic resistance between the measure resistor and the measurement apparatus), and of fluctuation of ± 0.01666 in the estimation of k .

The measurement of actual input resistance is somehow easier since we have access to both terminals, but of course due to the trimming system this measurement must be performed with the ADC powered.

Performing the measurement as describe here above should reduce the discrepancy between computed value and measured value for input impedance (cf all resistors are now measured at similar temperatures).

Due to extra routing between pad and termination resistor for analog inputs the measured differential value should be $\sim 2\Omega$ above the computed value.

As a consequence we should revise the formula for input impedance given in section 7.7.12 as following:

$R = 1 + (121*k / (2 + 0.006*(8*bit3 + 4*bit2 + 2*bit1 + bit0)))$ where k is the computed value for RES62 and RES50 measurements, representing the process deviation from ideality ($k = 1 \iff$ perfectly centered process), and where the first term 1 is the serial parasitic resistor between pad and actual termination resistor.

The trimming is meant to compensate for die process deviation (accepted value by foundry is $\pm 15\%$), after trimming it is always possible to reach the 50Ω (100Ω differential) value $\pm 2\%$ which is consistent with accepted tolerance of discrete passive devices.

When the die process is well centered (that is when k is close enough to 1) no trimming is necessary (default programming is OK) except if due to PCB process issues the actual input trace impedance deviates significantly from 50Ω and need to be matched internally.

The same trimming value should be applied for parts yielding the same measured values for RES62 and RES50.

6.6 QUAD ADC Digital Interface (SPI)

The digital interface will be a standard SPI (3.3V CMOS pads, 1.8V core) with:

- 8 bits for the address A[7] to A[0] including a R/W bit (A[7] = R/W and is the MSB);
- 16 bits of data D[15] to D[0] with D[15] the MSB.

5 signals are required:

- RSTN for the SPI reset;
- SCLK for the SPI clock;
- CSN for the Chip Select;
- MISO for the Master In Slave Out SPI Output (MISO should be pulled up to Vcc using 1K – 3K3 resistor. Also MISO does not conform to full SPI specification and is not tristated when inactive. For full details, refer to EV8AQ165A application note.)
- MOSI for the Master Out Slave In SPI Input.

The MOSI sequence should start with one R/W bit:

- R/W = 0 is a read procedure
- R/W = 1 is a write procedure

6.6.1 Timings

Register Write to a 16-bit register:

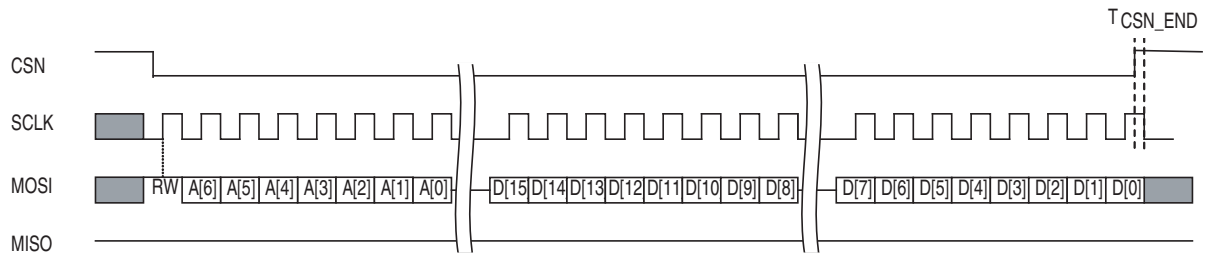

Note: Last falling edge of sclk should occur only once csn is back to high level at the end of the write procedure.

Register Read from a 16-bit register:

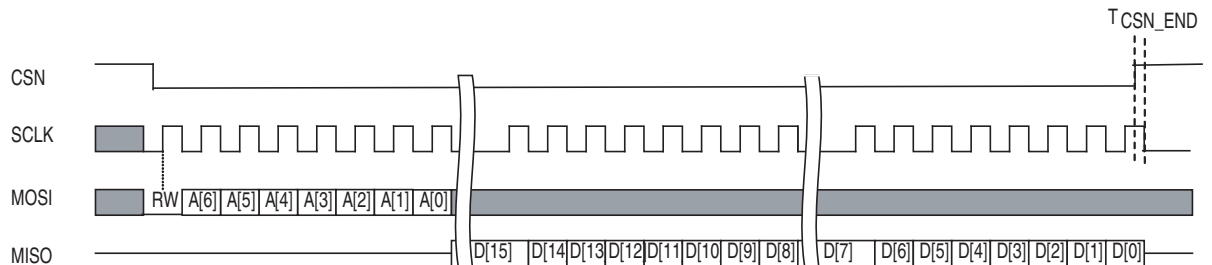

$$T_{\text{CSN_END}} = T_{\text{SCLK}}/4 = 12.5 \text{ ns (see note } (3) \text{)}$$

Table 6-2. Timing Characteristics

| Pin | Max Frequency | Setup (see note ⁽¹⁾) | Hold (see note ⁽¹⁾) | TPD Propagation Time |
|------------------------------|---------------|----------------------------------|---------------------------------|-----------------------|
| SCLK | 20 MHz | | | |
| CSN (to SCLK) ⁽²⁾ | | 1 ns | 1 ns | |
| MOSI (to SCLK) | | 1.2 ns | 1.0 ns | |
| MISO (to SCLK) | | | | min 1.5 ns / max 4 ns |

Notes: 1. 1st value is in Min Conditions, 2nd value is in Max Conditions.
 2. Setup/Hold to both SCLK edges.
 3. Last falling edge of sclk should occur once csn is set to 1, due to an internal operation.

6.6.2 Digital Reset (RSTN)

This is a global Reset for the SPI.

It is active Low.

There are 2 ways to reset the Quad 8-bit 1.25 GSps ADC:

- by asserting low the RSTN primary pad (hardware reset)
- by writing a '1' in the bit SWRESET of the SWRESET register through the SPI (software reset)

Both ways will clear ALL configuration registers to their reset values.

6.6.3 Registers Description

Table 6-3. Registers Mapping

| Address | Label | Description | R/W | Default Setting |
|--|------------------|--|------------------|--|
| Common Registers | | | | |
| 0x00 | Chip ID | Chip ID and version | Read Only | 0x0414 0x0418 (latest) |
| 0x01 | Control Register | ADC mode (channel mode) Standby Binary/gray Test Mode ON/OFF Bandwidth Selection | R/W | 4-channel mode (1.25 GSps) No standby Binary coding Test mode OFF Nominal bandwidth |
| 0x02 | STATUS | Status register | Read Only | |
| 0x04 | SWRESET | Software SPI reset | R/W | No reset |
| 0x05 | TEST | Test Mode | R/W | Test Pattern = ramp |
| 0x06 | SYNC | Programmable delay on ADC Data ready after Reset XDR, XDRN (4 bits), with X = A, B, C, D | R/W | 0 extra clock cycle |
| 0x0F | Channel Select | Channel X Selection | R/W | 0x0000 |
| Per Channel Registers (X = A/B/C/D) | | | | |
| 0x10 | Cal Ctrl X | Calibration control register of Channel X | R/W | |
| 0x11 | Cal Ctrl X Mlbox | Status/Busy of current Calibration of Channel X | Read Only (poll) | |
| 0x12 | Status X | Global Status of Channel X | Read Only | |
| 0x13 | Trimmer X | Impedance Trimmer of Channel X | R/W | 0x07 |

Table 6-3. Registers Mapping (Continued)

| Address | Label | Description | R/W | Default Setting |
|---------|--------------|---|-----------|-----------------|
| 0x20 | Ext Offset X | External Offset Adjustment of Channel X | R/W | 0 LSB |
| 0x21 | Offset X | Offset Adjustment of Channel X | Read Only | 0 LSB |
| 0x22 | Ext Gain X | External Gain Adjustment of Channel X | R/W | 0 dB |
| 0x23 | Gain X | Gain Adjustment of Channel X | Read Only | 0 dB |
| 0x24 | Ext Phase X | External Phase Adjustment of Channel X | R/W | 0 ps |
| 0x25 | Phase X | Phase Adjustment of Channel X | Read Only | 0 ps |

- Notes:
1. ALL registers are 16-bits long.
 2. The “external” gain/offset/phase adjustment registers correspond to the registers where one can write the external values to calibrate the gain/offset/phase parameters of the ADCs. The Gain/offset/phase adjustment registers are read only registers. They provide you with the internal settings for the gain/offset/phase parameters. The “external” and read only adjustment registers should give the same results two by two once any calibration has been performed.

6.6.4 Chip ID Register (Read Only)

Table 6-4. Chip ID Register Mapping: address 0x00

| Bit 15 | Bit 14 | Bit 13 | Bit 12 | Bit 11 | Bit 10 | Bit 9 | Bit 8 | Bit 7 | Bit 6 | Bit 5 | Bit 4 | Bit 3 | Bit 2 | Bit 1 | Bit 0 |
|--------|--------|--------|--------|--------|--------|-------|-------|-------------|-------|-------|-------|--------------|-------|-------|-------|
| TYPE | | | | | | | | BRANCH<3:0> | | | | VERSION<3:0> | | | |

Table 6-5. Chip ID Register Description

| Bit label | Value | Description | Default Setting |
|---------------|----------|----------------|-----------------|
| VERSION <3:0> | 0100 | Version Number | See Note |
| BRANCH<3:0> | 0001 | Branch Number | |
| TYPE<7:0> | 00001000 | Chip Type | |

Note: Version = 0x041C

6.6.5 Control Register

Table 6-6. Control Register Mapping: address 0x01

| Bit 15 | Bit 14 | Bit 13 | Bit 12 | Bit 11 | Bit 10 | Bit 9 | Bit 8 | Bit 7 | Bit 6 | Bit 5 | Bit 4 | Bit 3 | Bit 2 | Bit 1 | Bit 0 |
|-------------|--------|--------|--------|--------|--------|--------|-------|-------|--------|-------------|-------|---------------|-------|-------|-------|
| Unused<1:0> | | 0 | TEST | 0 | Unused | Unused | BDW | B/G | Unused | STDBY <1:0> | | ADCMODE <3:0> | | | |

Table 6-7. Control Register Description

| Bit label | Value | Description | Default Setting |
|---------------|-------------|---|-------------------------|
| ADCMODE <3:0> | 00XX | 4 Channels mode (1.25 GSps per channel) | 0000 4-channels Mode |
| | 0100 | 2 Channels mode (channel A and channel C, 2.5 GSps per channel) | |
| | 0101 | 2 Channels mode (channel B and channel C, 2.5 GSps per channel) | |
| | 0110 | 2 Channels mode (channel A and channel D, 2.5 GSps per channel) | |
| | 0111 | 2 Channels mode (channel B and channel D, 2.5 GSps per channel) | |
| | 1000 | 1 Channel mode (channel A, 5 GSps) | |
| | 1001 | 1 Channel mode (channel B, 5 GSps) | |
| | 1010 | 1 Channel mode (channel C, 5 GSps) | |
| | 1011 | 1 Channel mode (channel D, 5 GSps) | |
| | 1100 | Common input mode, simultaneous sampling (channel A) | |
| | 1101 | Common input mode, simultaneous sampling (channel B) | |
| | 1110 | Common input mode, simultaneous sampling (channel C) | |
| | 1111 | Common input mode, simultaneous sampling (channel D) | |
| | STDBY <1:0> | 00 | |
| 01 | | Standby channel A/channel B: - if 4-channels mode selected ‡ standby of channel A and B - if 2-channel mode selected ‡ standby of channel A or B - if 1-channel mode selected ‡ full standby - if Common input mode selected ‡ full standby | |
| 10 | | Standby channel C/channel D - if 4-channels mode selected ‡ standby of channel C and D - if 2-channels mode selected ‡ standby of channel C or D - if 1-channel mode selected ‡ full standby - if Common input mode selected ‡ full standby | |
| 11 | | Full Standby | |
| B/G | 0 | Binary | 0 |
| | 1 | Gray | Binary Coding |
| BDW | 0 | Nominal bandwidth (2 GHz typical) | 0 |
| | 1 | Full bandwidth | Nominal bandwidth |
| TEST | 0 | No Test Mode | 0 |
| | 1 | Test Mode Activated, Refer to the Test register | No Test Mode |

Table 6-8. Control Register Settings (address 0x01): Bit7 to Bit0

| Description | Bit 7 | Bit 6 | Bit 5 | Bit 4 | Bit 3 | Bit 2 | Bit 1 | Bit 0 |
|---|-------|--------|-------------|-------|---------------|-------|-------|-------|
| Label | B/G | Unused | STDBY <1:0> | | ADCMODE <3:0> | | | |
| 4-channels mode 1.25 GSps max per channel | X | X | X | X | 0 | 0 | X | X |
| 2-channels mode (channel A and channel C) 2.5 GSps max per channel | X | X | X | X | 0 | 1 | 0 | 0 |
| 2-channels mode (channel B and channel C) 2.5 GSps max per channel | X | X | X | X | 0 | 1 | 0 | 1 |
| 2-channels mode (channel A and channel D) 2.5 GSps max per channel | X | X | X | X | 0 | 1 | 1 | 0 |
| 2-channels mode (channel B and channel D) 2.5 GSps max per channel | X | X | X | X | 0 | 1 | 1 | 1 |
| 1-channel mode (Channel A, 5 GSps max) | X | X | X | X | 1 | 0 | 0 | 0 |
| 1-channel mode (Channel B, 5 GSps) | X | X | X | X | 1 | 0 | 0 | 1 |
| 1-channel mode (Channel C, 5 GSps) | X | X | X | X | 1 | 0 | 1 | 0 |
| 1-channel mode (Channel D, 5 GSps) | X | X | X | X | 1 | 0 | 1 | 1 |
| Common input mode, simultaneous sampling 1.25 GSps max (channel A) | X | X | X | X | 1 | 1 | 0 | 0 |
| Common input mode, simultaneous sampling 1.25 GSps max (channel B) | X | X | X | X | 1 | 1 | 0 | 1 |
| Common input mode, simultaneous sampling 1.25 GSps max (channel C) | X | X | X | X | 1 | 1 | 1 | 0 |
| Common input mode, simultaneous sampling 1.25 GSps max (channel D) | X | X | X | X | 1 | 1 | 1 | 1 |
| No standby | X | X | 0 | 0 | X | X | X | X |
| Standby channel A, channel B | X | X | 0 | 1 | X | X | X | X |
| Standby channel C, channel D | X | X | 1 | 0 | X | X | X | X |
| Full Standby | X | X | 1 | 1 | X | X | X | X |
| Binary Coding | 0 | X | X | X | X | X | X | X |
| Gray Coding | 1 | X | X | X | X | X | X | X |

Table 6-9. Control Register Settings (address 0x01): Bit15 to Bit8

| Description | Bit 15 | Bit 14 | Bit 13 | Bit 12 | Bit 11 | Bit 10 | Bit 9 | Bit 8 |
|-------------------|-------------|--------|----------|--------|----------|--------|--------|-------|
| Label | Unused<1:0> | | Reserved | TEST | Reserved | Unused | Unused | BDW |
| Nominal bandwidth | X | X | 0 | X | 0 | X | X | 0 |
| Full bandwidth | X | X | 0 | X | 0 | X | X | 1 |
| Test Mode OFF | X | X | 0 | 0 | 0 | X | X | X |
| Test Mode ON | X | X | 0 | 1 | 0 | X | X | X |

Note: 1. It is mandatory to apply a SYNCP, SYN CN signal to the ADC when the Test Mode is activated.

Table 6-10. ADCMODE and STBY allowed combinations

| Description | Bit 7 | Bit 6 | Bit 5 | Bit 4 | Bit 3 | Bit 2 | Bit 1 | Bit 0 |
|---|-------|--------|-------------|-------|---------------|-------|-------|-------|
| Label | B/G | Unused | STDBY <1:0> | | ADCMODE <3:0> | | | |
| 4-channels mode, 1.25 GSps max No standby | X | X | 0 | 0 | 0 | 0 | X | X |
| 4-channels mode, 1.25 GSps max Standby channel A, channel B | X | X | 0 | 1 | 0 | 0 | X | X |
| 4-channels mode, 1.25 GSps max Standby channel C, channel D | X | X | 1 | 0 | 0 | 0 | X | X |
| 4-channels mode (1.25 GSps max) Full Standby | X | X | 1 | 1 | 0 | 0 | X | X |
| 2-channels mode, 2.5 GSps max (Channels A and C) No Standby | X | X | 0 | 0 | 0 | 1 | 0 | 0 |
| 2-channels mode, 2.5 GSps max (Channels A and C) Standby channel A | X | X | 0 | 1 | 0 | 1 | 0 | 0 |
| 2-channels mode, 2.5 GSps max (Channels A and C) Standby Channel C | X | X | 1 | 0 | 0 | 1 | 0 | 0 |
| 2-channels mode, 2.5 GSps max (Channels A and C) Full Standby | X | X | 1 | 1 | 0 | 1 | 0 | 0 |
| 2-channels mode, 2.5 GSps max (Channels B and C) No Standby | X | X | 0 | 0 | 0 | 1 | 0 | 1 |
| 2-channels mode, 2.5 GSps max (Channels B and C) Standby Channel B | X | X | 0 | 1 | 0 | 1 | 0 | 1 |
| 2-channels mode, 2.5 GSps max (Channels B and C) Standby Channel C | X | X | 1 | 0 | 0 | 1 | 0 | 1 |
| 2-channels mode, 2.5 GSps max (Channels B and C) Full Standby | X | X | 1 | 1 | 0 | 1 | 0 | 1 |
| 2-channels mode, 2.5 GSps max (Channel A and D) No Standby | X | X | 0 | 0 | 0 | 1 | 1 | 0 |
| 2-channels mode, 2.5 GSps max (Channels A and D) Standby Channel A | X | X | 0 | 1 | 0 | 1 | 1 | 0 |
| 2-channels mode, 2.5 GSps max (Channels A and D) Standby Channel D | X | X | 1 | 0 | 0 | 1 | 1 | 0 |
| 2-channels mode, 2.5 GSps max (Channels A and D) Full Standby | X | X | 1 | 1 | 0 | 1 | 1 | 0 |
| 2-channels mode, 2.5 GSps max (Channels B and D) No Standby | X | X | 0 | 0 | 0 | 1 | 1 | 1 |
| 2-channels mode, 2.5 GSps max (Channels B and D) Standby Channel B | X | X | 0 | 1 | 0 | 1 | 1 | 1 |
| 2-channels mode, 2.5 GSps max (channels B and D) Standby Channel D | X | X | 1 | 0 | 0 | 1 | 1 | 1 |
| 2-channels mode, 2.5 GSps max (channels B and D) Full Standby | X | X | 1 | 1 | 0 | 1 | 1 | 1 |

Table 6-10. ADCMODE and STBY allowed combinations (Continued)

| Description | Bit 7 | Bit 6 | Bit 5 | Bit 4 | Bit 3 | Bit 2 | Bit 1 | Bit 0 |
|---|-------|-------|----------------------|-------|-------|-------|-------|-------|
| 1-channel mode (Channel A, 5 GSps max) No Standby | X | X | 0 | 0 | 1 | 0 | 0 | 0 |
| 1-channel mode (Channel B, 5 GSps max) No Standby | X | X | 0 | 0 | 1 | 0 | 0 | 1 |
| 1-channel mode (Channel C, 5 GSps max) No Standby | X | X | 0 | 0 | 1 | 0 | 1 | 0 |
| 1-channel mode (Channel D, 5 GSps) No Standby | X | X | 0 | 0 | 1 | 0 | 1 | 1 |
| 1-channel mode (Channel A, 5 GSps) Full Standby | X | X | 01 or 10 or 11 | | 1 | 0 | 0 | 0 |
| 1-channel mode (Channel B, 5 GSps) Full Standby | X | X | 01 or 10 or 11 | | 1 | 0 | 0 | 1 |
| 1-channel mode (Channel C, 5 GSps) Full Standby | X | X | 01 or 10 or 11 | | 1 | 0 | 1 | 0 |
| 1-channel mode (Channel D, 5 GSps) Full Standby | X | X | 01 or 10 or 11 | | 1 | 0 | 1 | 1 |
| Common input mode (Channel A, 1.25 GSps) No Standby | X | X | 0 | 0 | 1 | 1 | 0 | 0 |
| Common input mode (Channel B, 1.25 GSps) No Standby | X | X | 0 | 0 | 1 | 1 | 0 | 1 |
| Common input mode (Channel C, 1.25 GSps) No Standby | X | X | 0 | 0 | 1 | 1 | 1 | 0 |
| Common input mode (Channel D, 1.25 GSps) No Standby | X | X | 0 | 0 | 1 | 1 | 1 | 1 |
| Common input mode (Channel A , 1.25 GSps) Full standby | X | X | 01 or 10 or 11 | | 1 | 1 | 0 | 0 |
| Common input mode (Channel B , 1.25 GSps) Full standby | X | X | 01 or 10 or 11 | | 1 | 1 | 0 | 1 |
| Common input mode (Channel C , 1.25 GSps) Full standby | X | X | 01 or 10 or 11 | | 1 | 1 | 1 | 0 |
| Common input mode (Channel D , 1.25 GSps) Full standby | X | X | 01 or 10 or 11 | | 1 | 1 | 1 | 1 |

6.6.6 STATUS Register (Read Only)

Table 6-11. STATUS Register Mapping: address 0x02

| Bit 15 | Bit 14 | Bit 13 | Bit 12 | Bit 11 | Bit 10 | Bit 9 | Bit 8 | Bit 7 | Bit 6 | Bit 5 | Bit 4 | Bit 3 | Bit 2 | Bit 1 | Bit 0 |
|--------|--------|--------|--------|--------|--------|-------|-------|-------|-------|-------|-------|-------------|-------|-------|-------|
| Unused | | | | | | | | | | | | ADCXUP<3:0> | | | |

Table 6-12. STATUS Register Description

| Bit label | Value | Description | Default Setting |
|-------------|-------|---------------|-----------------|
| ADCXUP<3:0> | XXX0 | ADC A standby | 1111 |
| | XXX1 | ADC A active | |
| | XX0X | ADC B standby | |
| | XX1X | ADC B active | |
| | X0XX | ADC C standby | |
| | X1XX | ADC C active | |
| | 0XXX | ADC D standby | |
| | 1XXX | ADC D active | |

6.6.7 SWRESET Register

Table 6-13. SWRESET Register Mapping: address 0x04

| Bit 15 | Bit 14 | Bit 13 | Bit 12 | Bit 11 | Bit 10 | Bit 9 | Bit 8 | Bit 7 | Bit 6 | Bit 5 | Bit 4 | Bit 3 | Bit 2 | Bit 1 | Bit 0 |
|--------|--------|--------|--------|--------|--------|-------|-------|-------|-------|-------|-------|-------|-------|-------|---------|
| Unused | | | | | | | | | | | | | | | SWRESET |

Table 6-14. SWRESET Register Description

| Bit label | Value | Description | Default Setting |
|-----------|-------|---|-------------------|
| SWRESET | 0 | No Software Reset | 0 |
| | 1 | Unconditional Software Reset (see Note) | No software reset |

Note: Global Software Reset will reset ALL design registers (configuration registers as well as any flip-flop in the digital part of the design). This bit is automatically reset to 0 after some ns. There is no need to clear it by an external access.

6.6.8 TEST Register

Table 6-15. TEST Register Mapping: address 0x05

| Bit 15 | Bit 14 | Bit 13 | Bit 12 | Bit 11 | Bit 10 | Bit 9 | Bit 8 | Bit 7 | Bit 6 | Bit 5 | Bit 4 | Bit 3 | Bit 2 | Bit 1 | Bit 0 |
|--------|--------|--------|--------|--------|--------|-------|-------|-------|--------|-------|-------|-------|--------|-------|-------|
| Unused | | | | | | | | | Unused | | "00" | | FlashM | | TESTM |

Table 6-16. TEST Register Description

| Bit label | Value | Description | Default Setting |
|-----------|-------|---|--------------------------|
| TESTM | 0 | Not used | |
| | 1 | Flashing mode (refer to Bit 1 and Bit 2 to select the flashing 1 period) | |
| FlashM | 00 | Flashing "11" mode = 1 (FF pattern every ten 00 patterns) on each ADC | 00 Flashing "11" mode |
| | 01 | Flashing "12" mode = 1 (FF pattern every eleven 00 patterns) on each ADC | |
| | 10 | Flashing "16" mode = 1 (FF pattern every fifteen 00 patterns) on each ADC | |

- Notes:
1. TESTM is taken into account only if bit12 (TEST) of Control register (address 0x01) is at 1.
 2. It is mandatory to apply a SYNCp, SYNCn signal to the ADC when the Test Mode is activated.
 3. When Bit 0 is set to 1, it is necessary to choose the flashing "1" period (11, 12 or 16) using Bit 1 and Bit 2. The default flashing mode is the one with 11 period.
 4. Flashing mode FF pattern on 9bit (Out of range bit + data 8bit)

6.6.9 SYNC Register Mapping

Table 6-17. SYNC Register Mapping: address 0x06

| Bit 15 | Bit 14 | Bit 13 | Bit 12 | Bit 11 | Bit 10 | Bit 9 | Bit 8 | Bit 7 | Bit 6 | Bit 5 | Bit 4 | Bit 3 | Bit 2 | Bit 1 | Bit 0 |
|--------|--------|--------|--------|--------|--------|-------|-------|-------|-------|-------|-------|-----------|-------|-------|-------|
| Unused | | | | | | | | | | | | SYNC<3:0> | | | |

Table 6-18. SYNC Register Description

| Bit label | Value | Description | Default Setting |
|-----------|-------|--|-----------------------|
| SYNC<3:0> | 0000 | 0 extra external clock cycle (CLK) before starting up | 0000 0 Clock Cycle |
| | 0001 | 1 extra external clock cycle (CLK)before starting up | |
| | ... | ... | |
| | 1111 | 15 extra external clock cycles (CLK)before starting up | |

6.6.10 CHANNEL SELECTOR Register

Table 6-19. CHANNEL SELECTOR Register Mapping: address 0x0F

| Bit 15 | Bit 14 | Bit 13 | Bit 12 | Bit 11 | Bit 10 | Bit 9 | Bit 8 | Bit 7 | Bit 6 | Bit 5 | Bit 4 | Bit 3 | Bit 2 | Bit 1 | Bit 0 |
|--------|--------|--------|--------|--------|--------|-------|-------|-------|-------|-------|-------|-------|------------------------|-------|-------|
| Unused | | | | | | | | | | | | | Channel Selector <2:0> | | |

Table 6-20. CHANNEL SELECTOR Register Description

| Bit label | Value | Description | Default Setting |
|------------------------|------------|--|----------------------------|
| Channel Selector <2:0> | 000 | No channel selected (only common registers are accessible) | 000 No channel selected |
| | 001 | Channel A selected to access to “per-channel” registers | |
| | 010 | Channel B selected to access to “per-channel” registers | |
| | 011 | Channel C selected to access to “per-channel” registers | |
| | 100 | Channel D selected to access to “per-channel” registers | |
| | Any others | No channel selected (only common registers are accessible) | |

Note: The CHANNEL SELECTOR register has to be set before any access to “per-channel” registers in order to determine which channel is targeted.

6.6.11 CAL Control Registers

Applies to CAL Control registers A, B, C and D according to CHANNEL SELECTOR register contents.

Table 6-21. CAL Control Register Mapping: address 0x10

| Bit 15 | Bit 14 | Bit 13 | Bit 12 | Bit 11 | Bit 10 | Bit 9 | Bit 8 | Bit 7 | Bit 6 | Bit 5 | Bit 4 | Bit 3 | Bit 2 | Bit 1 | Bit 0 |
|--------|--------|--------|--------|--------|--------|-------|-------|---------------------|---------------------|---------------------|-------|-------|-------|-------|-------|
| Unused | | | | | | | | PCALCTRL X <1:0> | GCALCTRL X <1:0> | OCALCTRL X <1:0> | “00” | | | | |

Table 6-22. CAL Control Register Description

| Bit label | Value | Description | Default Setting |
|------------------|-------|--|-----------------|
| OCALCTRL X <1:0> | 00 | Idle mode for selected channel | 00 |
| | 01 | Idle mode for selected channel | |
| | 10 | External Offset adjust for selected channel (transfer of Ext Offset register content into current Offset register) | |
| | 11 | Idle mode for selected channel | |
| GCALCTRL X <1:0> | 00 | Idle mode for selected channel | 00 |
| | 01 | Idle mode for selected channel | |
| | 10 | External Gain adjust for selected channel (transfer of Ext Gain register content into current Gain register) | |
| | 11 | Idle mode for selected channel | |
| PCALCTRL X <1:0> | 00 | Idle mode for selected channel | 00 |
| | 01 | Idle mode for selected channel | |
| | 10 | External Phase adjust for selected channel (transfer of Ext Phase register content into current Phase register) | |
| | 11 | Idle mode for selected channel | |

Notes: 1. Writing to the register will start the corresponding operation(s). In that case, the Status/Busy bit of the mailbox (see below) is asserted until the operation is over. (At the end of a calibration/tuning process, CAL Control register relevant bit slice is NOT reset to default value.)

2. If different calibrations are ordered, they are performed successively following the priority order defined hereafter.
- Gain has priority over Offset, and Phase
 - Offset has priority over Phase.

Indeed, the transfer function of the ADC is given by the following formula transfer function result = offset + (input*gain).

6.6.12 CAL Control Registers Mailbox (Read Only)

Applies to CAL Control Registers Mailbox A, B, C and D according to CHANNEL SELECTOR register contents.

Table 6-23. CAL Control Registers Mailbox Register Mapping: address 0x11

| | | | | | | | | | | | | | | | |
|--------------|--------|--------|--------|--------|--------|-------|-------|-------|-------|-------|-------|-------|-------|-------|---------------|
| Bit 15 | Bit 14 | Bit 13 | Bit 12 | Bit 11 | Bit 10 | Bit 9 | Bit 8 | Bit 7 | Bit 6 | Bit 5 | Bit 4 | Bit 3 | Bit 2 | Bit 1 | Bit 0 |
| Unused<12:0> | | | | | | | | | | | | | | | STATUS/BUSY X |

6.6.13 GLOBAL STATUS Register (Read Only)

Applies to GLOBAL STATUS registers A, B, C and D according to CHANNEL SELECTOR register contents.

Table 6-24. GLOBAL STATUS Register Mapping: address 0x12

| | | | | | | | | | | | | | | | |
|--------|--------|--------|--------|--------|--------|-------|-------|-------|-------|-------|-------|-------|-------|-------|--------|
| Bit 15 | Bit 14 | Bit 13 | Bit 12 | Bit 11 | Bit 10 | Bit 9 | Bit 8 | Bit 7 | Bit 6 | Bit 5 | Bit 4 | Bit 3 | Bit 2 | Bit 1 | Bit 0 |
| Unused | | | | | | | | | | | | | | | STBY X |

Table 6-25. GLOBAL STATUS Register Description

| Bit label | Value | Description | Default Setting |
|-----------|-------|--------------------------------|-----------------|
| STBY X | 0 | Selected Channel is in standby | 0 |
| | 1 | Selected Channel is active | |

6.6.14 TRIMMER Register

Applies to TRIMMER registers A, B, C and D according to CHANNEL SELECTOR register contents.

Table 6-26. TRIMMER Register Mapping: address 0x13

| | | | | | | | | | | | | | | | |
|--------|--------|--------|--------|--------|--------|-------|-------|-------|-------|-------|-------|-----------------|-------|-------|-------|
| Bit 15 | Bit 14 | Bit 13 | Bit 12 | Bit 11 | Bit 10 | Bit 9 | Bit 8 | Bit 7 | Bit 6 | Bit 5 | Bit 4 | Bit 3 | Bit 2 | Bit 1 | Bit 0 |
| Unused | | | | | | | | | | | | TRIMMER X <3:0> | | | |

Table 6-27. TRIMMER Register Description

| Bit label | Value | Description | Default Setting |
|-----------------|-------|-------------|-----------------|
| TRIMMER X <3:0> | 0000 | +10.00 Ω | 0111 50Ω |
| | 0001 | +8.34 Ω | |
| | 0010 | +6.77 Ω | |
| | 0011 | +5.29 Ω | |
| | 0100 | +3.89 Ω | |
| | 0101 | +2.57 Ω | |
| | 0110 | +1.31 Ω | |
| | 0111 | +0.11 Ω | |
| | 1000 | -1.03 Ω | |
| | 1001 | -2.12 Ω | |
| | 1010 | -3.15 Ω | |
| | 1011 | -4.14 Ω | |
| | 1100 | -5.09 Ω | |
| | 1101 | -5.99 Ω | |
| | 1110 | -6.86 Ω | |
| | 1111 | -7.69 Ω | |

Note: $R = 3 + (114 / [2 + 0.06 \times (8 \times \text{bit3} + 4 \times \text{bit2} + 2 \times \text{bit1} + 1 \times \text{bit0})])$ – the practical results (simulated) are not exactly the ones given above.

Refer to [Section 6.5 "Res50 and Res62" on page 40](#) for more information.

6.6.15 External Offset Registers

Apply to External Offset Registers A, B, C and D according to CHANNEL SELECTOR register contents.

Table 6-28. External Offset Control Register Mapping: address 0x20

| Bit 15 | Bit 14 | Bit 13 | Bit 12 | Bit 11 | Bit 10 | Bit 9 | Bit 8 | Bit 7 | Bit 6 | Bit 5 | Bit 4 | Bit 3 | Bit 2 | Bit 1 | Bit 0 |
|---------------|--------|--------|--------|--------|--------|-------------------------------------|-------|-------|-------|-------|-------|-------|-------|-------|-------|
| <i>Unused</i> | | | | | | EXTERNAL OFFSET X <9:0> (See Notes) | | | | | | | | | |

Table 6-29. External Offset Control Register Description

| Bit label | Value | Description | Default Setting |
|------------------------|-------|---------------------------------|-----------------------|
| EXTERNAL OFFSET X<9:0> | 0x000 | Maximum positive offset applied | 0x200 0 LSB Offset |
| | 0x1FF | Minimum positive offset applied | |
| | 0x200 | Minimum negative offset applied | |
| | 0x3FF | Maximum negative offset applied | |

- Notes:
- Offset variation range: $\sim \pm 20$ LSB, 1024 steps.
 - Current offset of the selected channel is controlled by the External Offset Control Register but is updated only upon request placed through the SPI in the CAL control register of the selected channel.
 - The transfer function of the ADC is given by the following formula transfer function result = offset + (input*gain).

6.6.16 Offset Registers (Read Only)

Apply to Offset Registers A, B, C and D according to CHANNEL SELECTOR register contents.

Table 6-30. Offset Control Register Mapping: address 0x21

| Bit 15 | Bit 14 | Bit 13 | Bit 12 | Bit 11 | Bit 10 | Bit 9 | Bit 8 | Bit 7 | Bit 6 | Bit 5 | Bit 4 | Bit 3 | Bit 2 | Bit 1 | Bit 0 |
|--------|--------|--------|--------|--------|--------|----------------------------|-------|-------|-------|-------|-------|-------|-------|-------|-------|
| Unused | | | | | | OFFSET X <9:0> (See Notes) | | | | | | | | | |

Table 6-31. Offset Control Register Description

| Bit label | Value | Description | Default Setting |
|----------------|-------|---------------------------------|-----------------------|
| OFFSET X <9:0> | 0x000 | Maximum positive offset applied | 0x200 0 LSB Offset |
| | 0x1FF | Minimum positive offset applied | |
| | 0x200 | Minimum negative offset applied | |
| | 0x3FF | Maximum negative offset applied | |

- Notes:
1. Offset variation range: $\sim\pm 40$ LSB, 1024 steps.
 2. Current offset of the selected channel is controlled by the External Offset Control Register but is updated only upon request placed through the SPI in the CAL control register of the selected channel.
 3. The transfer function of the ADC is given by the following formula transfer function result = offset + (input*gain).

6.6.17 External Gain Control Registers

Apply to External Gain Control registers A, B, C and D according to CHANNEL SELECTOR register contents.

Table 6-32. External Gain Control Register Mapping: address 0x22

| Bit 15 | Bit 14 | Bit 13 | Bit 12 | Bit 11 | Bit 10 | Bit 9 | Bit 8 | Bit 7 | Bit 6 | Bit 5 | Bit 4 | Bit 3 | Bit 2 | Bit 1 | Bit 0 |
|--------|--------|--------|--------|--------|--------|-----------------------------------|-------|-------|-------|-------|-------|-------|-------|-------|-------|
| Unused | | | | | | EXTERNAL GAIN X <9:0> (See Notes) | | | | | | | | | |

Table 6-33. External Gain Control Register Description

| Bit label | Value | Description | Default Setting |
|-----------------------|-------|--|--------------------|
| EXTERNAL GAIN X <9:0> | 0x000 | Gain shrunk to min accessible value | 0x200 0 dB gain |
| | 0x200 | Gain at Default value (no correction, actual gain follow process scattering) | |
| | | | |
| | 0x3FF | Gain Increased to max accessible value | |

- Notes:
1. Gain variation range: $\sim\pm 10\%$, 1024 steps (1 step $\sim 0.02\%$).
 2. Current gain of the selected channel is controlled by the External Gain Control Register but is updated only upon request placed through the SPI in the CAL control register of the selected channel.
 3. The transfer function of the ADC is given by the following formula transfer function result = offset + (input*gain).

6.6.18 Gain Control Registers (Read Only)

Apply to Gain Control registers A, B, C and D according to CHANNEL SELECTOR register contents.

Table 6-34. Gain Control Register Mapping: address 0x23

| Bit 15 | Bit 14 | Bit 13 | Bit 12 | Bit 11 | Bit 10 | Bit 9 | Bit 8 | Bit 7 | Bit 6 | Bit 5 | Bit 4 | Bit 3 | Bit 2 | Bit 1 | Bit 0 |
|--------|--------|--------|--------|--------|--------|--------------------------|-------|-------|-------|-------|-------|-------|-------|-------|-------|
| Unused | | | | | | GAIN X <9:0> (See Notes) | | | | | | | | | |

Table 6-35. Gain Control Register Description

| Bit label | Value | Description | Default Setting |
|--------------|-------|--|--------------------|
| GAIN X <9:0> | 0x000 | Gain shrunk to min accessible value | 0x200 0 dB gain |
| | 0x200 | Gain at Default value (no correction, actual gain follow process scattering) | |
| | | | |
| | 0x3FF | Gain Increased to max accessible value | |

- Notes:
1. Gain variation range: $\sim\pm 10\%$, 1024 steps (1 step $\sim 0.02\%$).
 2. Current gain of the selected channel is controlled by the External Gain Control Register but is updated only upon request placed through the SPI in the CAL control register of the selected channel.
 3. The transfer function of the ADC is given by the following formula transfer function result = offset + (input*gain).

6.6.19 External Phase Registers

Apply to Phase Registers A, B, C and D according to CHANNEL SELECTOR register contents.

Table 6-36. External Phase Register Mapping: address 0x24

| Bit 15 | Bit 14 | Bit 13 | Bit 12 | Bit 11 | Bit 10 | Bit 9 | Bit 8 | Bit 7 | Bit 6 | Bit 5 | Bit 4 | Bit 3 | Bit 2 | Bit 1 | Bit 0 |
|--------|--------|--------|--------|--------|--------|------------------------------------|-------|-------|-------|-------|-------|-------|-------|-------|-------|
| Unused | | | | | | EXTERNAL PHASE X <9:0> (See Notes) | | | | | | | | | |

Table 6-37. External Phase Control Register Description

| Bit label | Value | Description | Default Setting |
|------------------------|-------|---|---|
| EXTERNAL PHASE X <9:0> | 0x000 | ~ -15 ps correction on selected channel aperture Delay | 0x200 0 ps correction on ADC X aperture Delay |
| | | | |
| | 0x3FF | $\sim +15$ ps correction on selected channel aperture Delay | |

- Notes:
1. Delay control range for edges of internal sampling clocks: $\sim\pm 15$ ps (1 step ~ 30 fs).
 2. Actual Aperture Delay of the selected channel is controlled by the External Phase Control Register but is updated only upon request placed through the SPI in the CAL control register of the selected channel.

6.6.20 Phase Registers (Read Only)

Apply to Phase Registers A, B, C and D according to CHANNEL SELECTOR register contents.

Table 6-38. Phase Register Mapping: address 0x25

| Bit 15 | Bit 14 | Bit 13 | Bit 12 | Bit 11 | Bit 10 | Bit 9 | Bit 8 | Bit 7 | Bit 6 | Bit 5 | Bit 4 | Bit 3 | Bit 2 | Bit 1 | Bit 0 |
|--------|--------|--------|--------|--------|--------|---------------------------|-------|-------|-------|-------|-------|-------|-------|-------|-------|
| Unused | | | | | | PHASE X <9:0> (See Notes) | | | | | | | | | |

Table 6-39. Phase Control Register Description

| Bit label | Value | Description | Default Setting |
|---------------|-------|--|---|
| PHASE X <9:0> | 0x000 | ~ -15 ps correction on selected channel aperture Delay | 0x200 0 ps correction on ADC X aperture Delay |
| | | | |
| | 0x3FF | ~ +15 ps correction on selected channel aperture Delay | |

- Notes:
1. Delay control range for edges of internal sampling clocks: $\sim \pm 15$ ps (1 step ~ 30 fs).
 2. Actual Aperture Delay of the selected channel is controlled by the External Phase Control Register but is updated only upon request placed through the SPI in the CAL control register of the selected channel.

7. Application Information

7.1 Bypassing, Decoupling and Grounding

All power supplies have to be decoupled to ground as close as possible to the signal accesses to the board by $1 \mu\text{F}$ in parallel to 100 nF .

Figure 7-1. EV8AQ165A Power supplies Decoupling and grounding Scheme

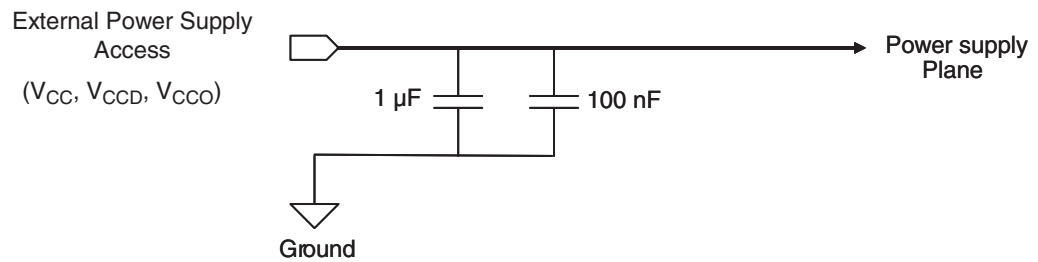

Note: V_{CCD} and V_{CCO} planes should be separated but the two power supplies can be reunited by a strap on the board.

It is recommended to decouple all power supplies to ground as close as possible to the device balls with 220 pF in parallel to 33 nF capacitors. The minimum number of decoupling pairs of capacitors can be calculated as the minimum number of groups of neighboring pins. 17 capacitors of 220 pF and 8 capacitors of 33 nF for V_{CC} ; 8 capacitors of 220 pF and 4 capacitors of 33 nF for V_{CCO} and one 220 pF capacitor with one 1 nF capacitor for V_{CCD} .

Figure 7-2. EV8AQ165A Power Supplies Bypassing Scheme

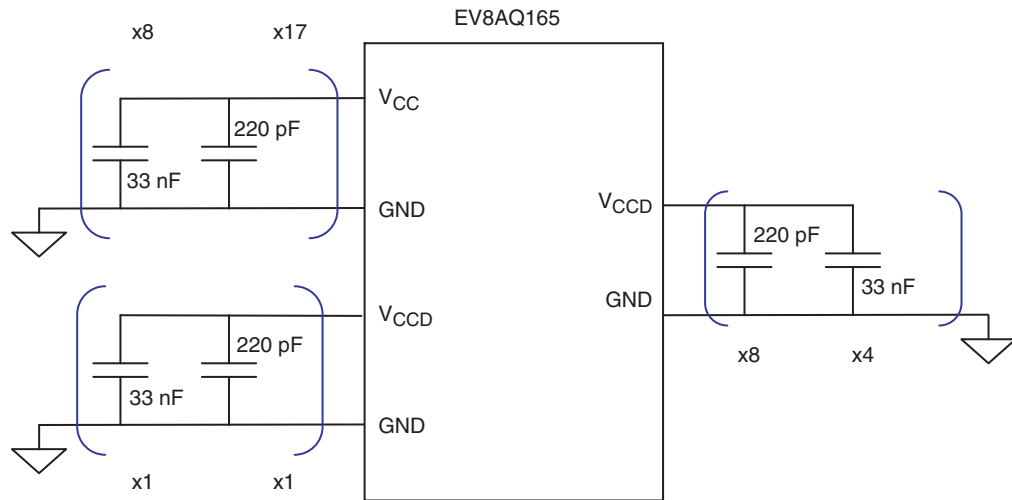

Each power supply has to be bypassed as close as possible to its source or access by 100 nF in parallel to 1 μ F capacitors.

7.2 Analog Inputs (VIN/VINN)

7.2.1 Differential analog input

The analog input can be either DC or AC coupled as described in [Figure 7-3](#) and [Figure 7-4](#).

Figure 7-3. Differential analog input implementation (AC coupled)

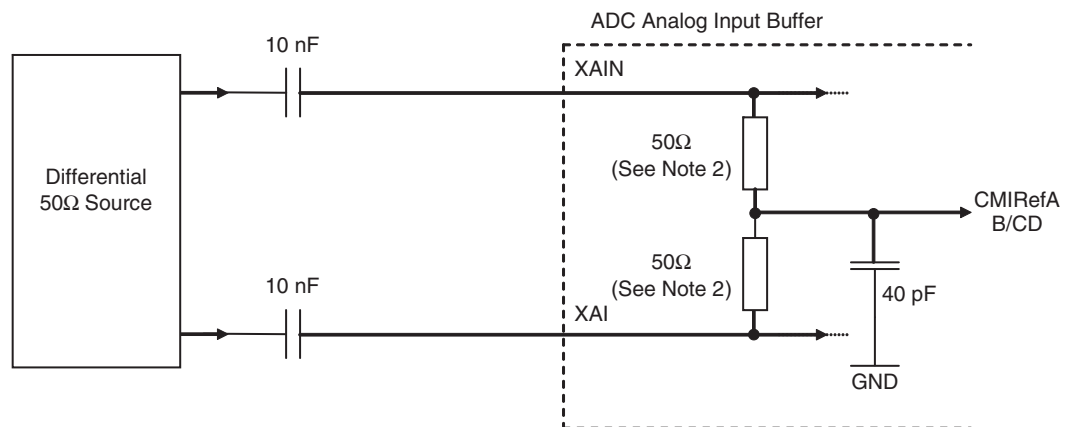

- Notes:
1. X = A, B, C or D
 2. The 50 Ω terminations are on chip.
 3. CMIRefAB/CD = 1.6V.

Figure 7-4. Differential analog input implementation (DC coupled)

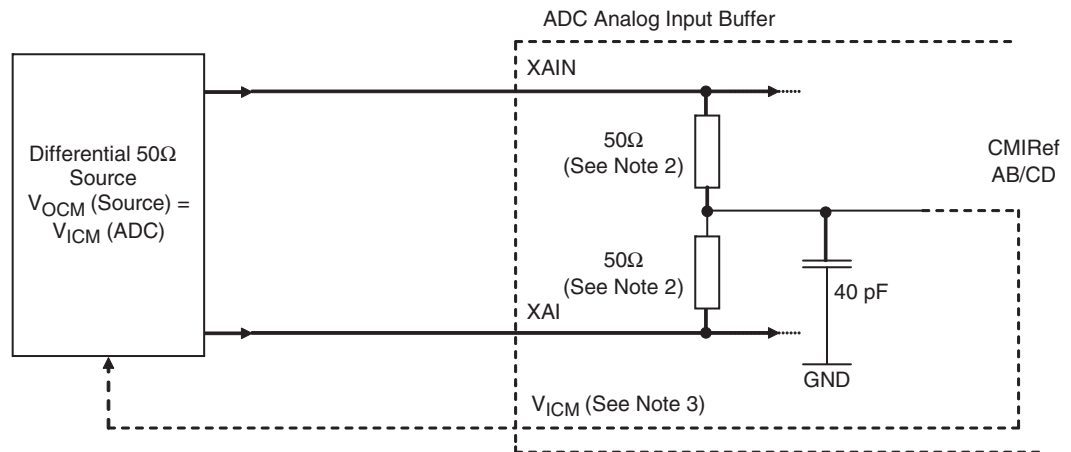

- Notes:
1. X = A, B, C or D
 2. The 50Ω terminations are implemented on-chip and can be fine tuned (TRIMMER register at address 0x13)
 3. CMIRrefAB/CD = 1.6V. The Common mode is output on signal CMIRrefAB for A and B channels and CMIRrefCD for C and D channels.

Note: If some Analog inputs are not used, they can be left unconnected (open).

Example: ADC in 1 channel mode with analog input signal on A channel.

-> Analog inputs B, C and D can be left unconnected

7.3 Clock Inputs (CLK/CLKN)

It is recommended to enter the clock input signal differential mode. Since the clock input common mode is around 1.8V, we recommend to AC couple the input clock as described in [Figure 7-5](#).

Figure 7-5. Differential Clock Input Implementation (AC coupled)

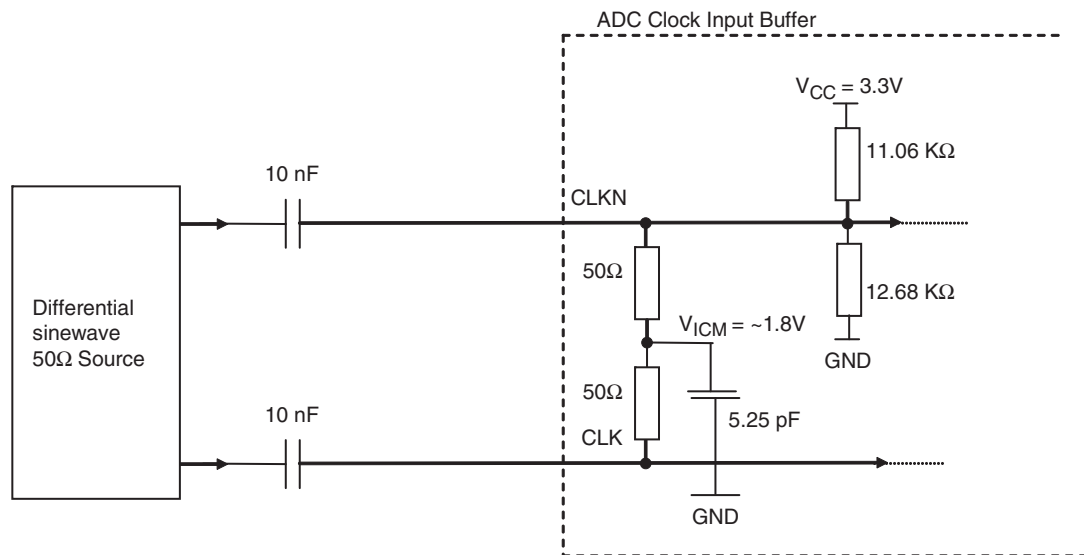

Differential mode is the recommended input scheme.

Single ended input is not recommended due to performance limitations.

7.4 Digital Outputs

The digital outputs are LVDS compatible. They have to be 100W differentially terminated.

Figure 7-6. Differential Digital Outputs Terminations (100Ω LVDS)

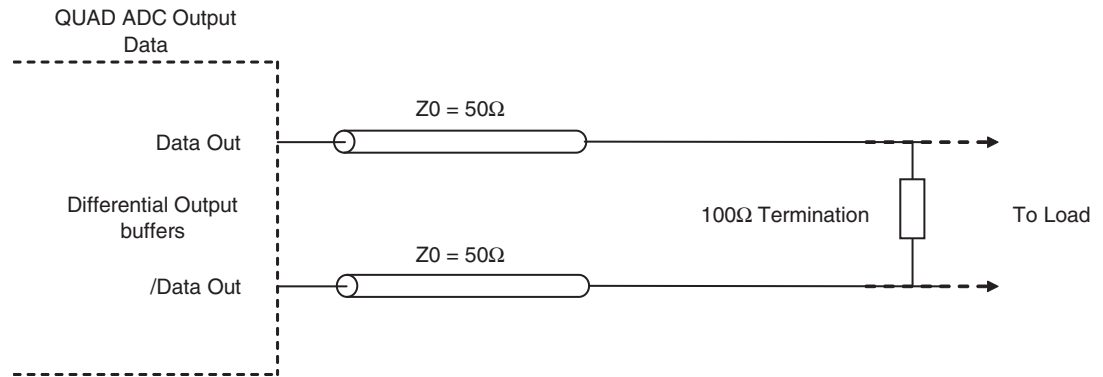

Note: If not used, leave the pins of the differential pair open

7.5 Reset Buffer (SYNCP, SYNCN)

The SYNCP, SYNCN signal has LVDS electrical characteristics. It is active high and should last at least 2 clock cycles to work properly

Figure 7-7. Reset Buffer (SYNCP, SYNCN)

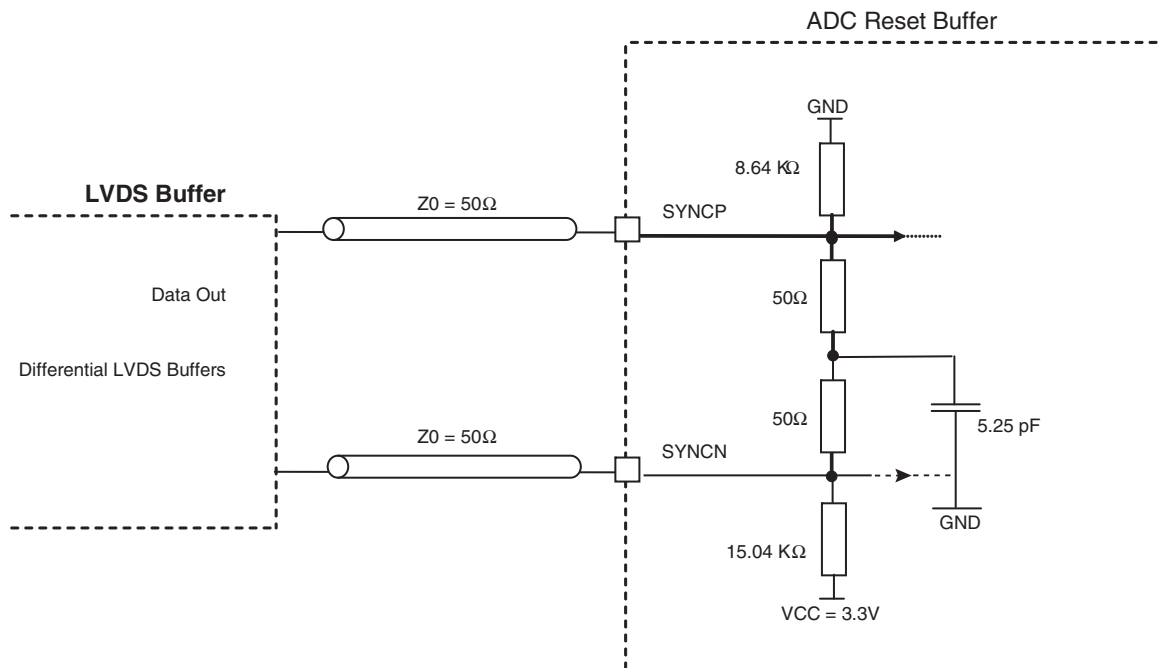

Note: If not used, leave the pins of the differential pair open

7.6 Calibration Procedure

The Quad ADC EV8AQ165A is made up of four 9-bit ADC cores which can be considered independently (4-channel mode) or grouped by 2 cores (2-channel mode with the ADCs interleaved two by two or 1-channel mode where all four ADCs are all interleaved).

The Time-interleaved ADC System can exhibit imperfect artifacts (distortion) in the frequency domain if the individual ADC core characteristics are not well matched. Offset, Gain and Phase (delay) are of primary concern.

When interleaved the 4 internal ADCs of EV8AQ165A need to be calibrated with Offset, Gain and Phase matching.

-> Each ADC must have as close as possible the same Offset, Gain and Phase.

Applications note 'Calibration Methodology for EV10AQ190A-Calibration 1081B' describes this procedure in detail.

8. Package Information

8.1 Package Outline

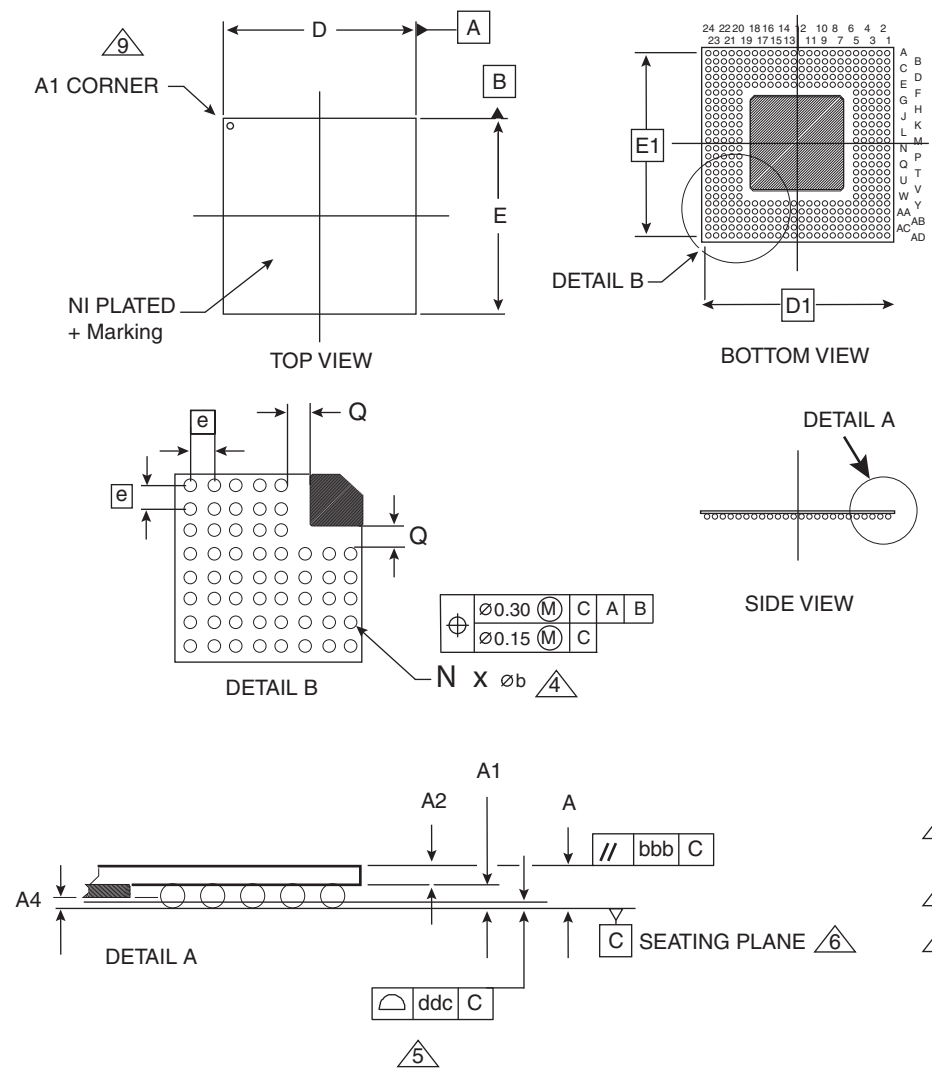

| DIMENSIONAL REFERENCES | | | |
|-------------------------------------|--------------|-------|-------|
| REF. | MIN. | NOM. | MAX. |
| A | 1.25 | 1.45 | 1.60 |
| A1 | 0.50 | 0.60 | 0.70 |
| D | 30.80 | 31.00 | 31.20 |
| D1 | 29.21 (BSC.) | | |
| E | 30.80 | 31.00 | 31.20 |
| E1 | 29.21 (BSC.) | | |
| b | 0.70 | 0.80 | 0.90 |
| A2 | 0.75 | 0.85 | 0.95 |
| M | 24 | | |
| N | 380 | | |
| bbb | | | 0.25 |
| ddd | | | 0.20 |
| e | 1.27 TYP | | |
| A4 | 0.15 | | |
| Q | 1.1 | | |
| REF: JEDEC MS-0.34B VARIATION BAK-1 | | | |

- Notes:
- All dimensions are in millimeters.
 - "e" represents the Basic Solder Ball Grid Pitch.
 - "M" represents the Basic Solder Ball Matrix Size. and symbol "N" is the maximum allowable number of balls after depopulating.
 - Dimension "b" is measured at the maximum solder Ball Diameter parallel to primary Datum C
 - Dimension "ddd" is measured parallel to primary Datum C
 - Primary Datum C and seating place are defined by the spherical crowns of the solder balls.
 - Package surface shall be Ni plated.
 - Encapsulant size may vary with die size.
 - Small round depression for PIN 1 identification.
 - "A4" is measured at the edge of encapsulant to the inner edge of ball pad.
 - Dimensioning and tolerancing per ASME Y14.5 1994
 - This drawing is for qualification purpose only.

8.2 EBGA380 Land Pattern Recommendations

E-BGA380

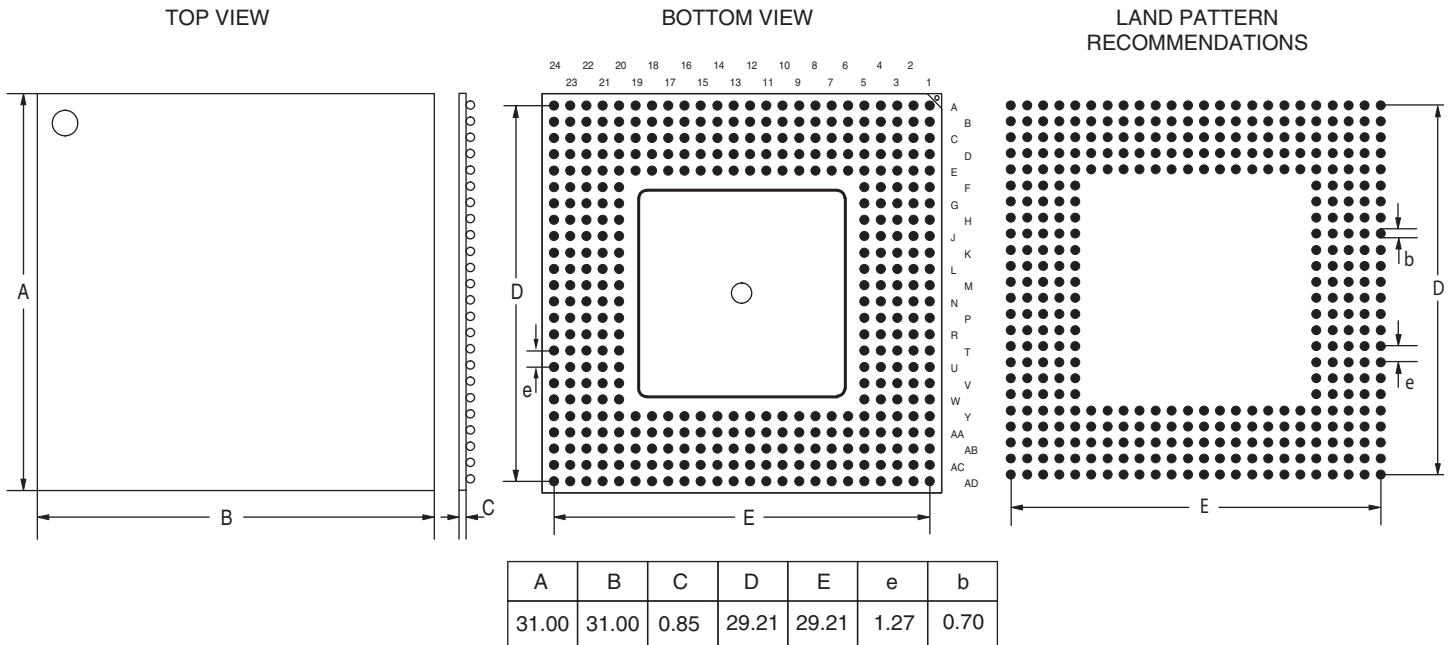

All dimensions are in millimeters

8.3 Thermal Characteristics

Assumptions:

- No air
- Pure conduction
- No radiation

8.3.1 Thermal Characteristics

- Rth Junction - bottom of Balls = 6.68°C/W
- Rth Junction - board (Jedec JESD541-8) = 7.38°C/W
- Rth Junction - top of case = 4.3°C/W
- Rth Junction - top of case with 50 µm thermal grease = 4.9°C/W
- Rth Junction - ambient (JEDEC standard, 49 x 49 mm² board size) = 16.3°C/W
- Rth Junction - ambient (180 x 170 mm² evaluation board size) = 12.8°C/W

8.3.2 Thermal Management Recommendations

In still air and 25°C ambient temperature conditions, the maximum temperature for the device soldered on the evaluation board is #84.5°C. For higher temperature, extra cooling is necessary.

In the case of the need of an external thermal management, it is recommended to have an external heatsink on top of the EBGA380 with a thermal resistance of 4°C/W max.

8.4 Moisture Characteristics

This device is sensitive to the moisture (MSL3 according to JEDEC standard).

Shelf life in sealed bag : 12 months at < 40°C and < 90% relative humidity (RH).

After this bag is opened, devices that will be subjected to infrared reflow, vapor-phase reflow, or equivalent processing (peak package body temp. 220°C) must be :

- mounted within 168 hours at factory conditions of $\leq 30^{\circ}\text{C}/60\% \text{ RH}$, or
- stored at $\leq 20\% \text{ RH}$

Devices require baking, before mounting, if Humidity Indicator is >20% when read at $23^{\circ}\text{C} \pm 5^{\circ}\text{C}$.

If baking is required, devices may be baked for :

- 192 hours at $40^{\circ}\text{C} + 5^{\circ}\text{C}/-0^{\circ}\text{C}$ and < 5% RH for low temperature device containers, or
- 24 hours at $125^{\circ}\text{C} \pm 5^{\circ}\text{C}$ for high-temperature device containers.

9. Ordering Information

Table 9-1. Ordering Information

| Part Number | Package | Temperature Range | Screening Level | Comments |
|---------------|--------------|---|-----------------|---|
| EVX8AQ165ATPY | EBGA380 RoHS | Ambient | Prototype | Contact e2v Sales Office for availability |
| EV8AQ165ACTPY | EBGA380 RoHS | Commercial $0^{\circ}\text{C} < T_C ; T_J < 90^{\circ}\text{C}$ | Standard | Contact e2v Sales Office for availability |
| EV8AQ165AVTPY | EBGA380 RoHS | Industrial $-40^{\circ}\text{C} < T_C ; T_J < 110^{\circ}\text{C}$ | Standard | Contact e2v Sales Office for availability |
| EVX8AQ165ATP | EBGA380 | Ambient | Prototype | Contact e2v Sales Office for availability |
| EV8AQ165ACTP | EBGA380 | Commercial $0^{\circ}\text{C} < T_C ; T_J < 90^{\circ}\text{C}$ | Standard | Contact e2v Sales Office for availability |
| EV8AQ165AVTP | EBGA380 | Industrial $-40^{\circ}\text{C} < T_C ; T_J < 110^{\circ}\text{C}$ | Standard | Contact e2v Sales Office for availability |

10. Revision History

This table provides revision history for this document.

Table 10-1. Revision History

| Rev. No | Date | Substantive Change(s) |
|---------|---------|-----------------------|
| 1119A | 10/2013 | Initial revision |

Table of Contents

| | | |
|----------|---|-----------|
| | <i>Main Features</i> | 1 |
| | <i>Performance</i> | 1 |
| | <i>Applications</i> | 2 |
| 1 | <i>Block Diagram</i> | 2 |
| 2 | <i>Description</i> | 2 |
| 3 | <i>Specifications</i> | 6 |
| | 3.1 Absolute Maximum Ratings | 6 |
| | 3.2 Recommended Conditions Of Use | 7 |
| | 3.3 Electrical Characteristics for supplies, Inputs and Outputs | 7 |
| | 3.4 Converter Characteristics | 10 |
| | 3.5 Transient and Switching Characteristics | 13 |
| | 3.6 Explanation of Test Levels | 14 |
| | 3.7 Timing Diagrams | 15 |
| | 3.8 Digital Output Coding | 18 |
| | 3.9 Definition of Terms | 20 |
| 4 | <i>Characterization Results</i> | 22 |
| 5 | <i>Pin Description</i> | 26 |
| | 5.1 Pinout View (Bottom view) | 26 |
| | 5.2 Pinout Table | 27 |
| 6 | <i>Theory of Operation</i> | 35 |
| | 6.1 Overview | 35 |
| | 6.2 ADC Synchronization Signal (SYNCP, SYNCN) | 36 |
| | 6.3 Digital Scan Mode (SCAN[2:0]) | 40 |
| | 6.4 Die Junction Temperature Monitoring Diode | 40 |
| | 6.5 Res50 and Res62 | 40 |
| | 6.6 QUAD ADC Digital Interface (SPI) | 42 |
| 7 | <i>Application Information</i> | 56 |
| | 7.1 Bypassing, Decoupling and Grounding | 56 |
| | 7.2 Analog Inputs (VIN/VINN) | 57 |
| | 7.3 Clock Inputs (CLK/CLKN) | 58 |
| | 7.4 Digital Outputs | 59 |

| | | |
|-----------|--|-----------|
| 7.5 | Reset Buffer (SYNCP, SYNCN) | 59 |
| 7.6 | Calibration Procedure | 60 |
| 8 | <i>Package Information</i> | 61 |
| 8.1 | Package Outline | 61 |
| 8.2 | EBGA380 Land Pattern Recommendations | 62 |
| 8.3 | Thermal Characteristics | 62 |
| 8.4 | Moisture Characteristics | 63 |
| 9 | <i>Ordering Information</i> | 63 |
| 10 | <i>Revision History</i> | 63 |



How to reach us

Home page: www.e2v.com

Sales offices:

Europe Regional sales office

e2v ltd

106 Waterhouse Lane
Chelmsford Essex CM1 2QU
England

Tel: +44 (0)1245 493493

Fax: +44 (0)1245 492492

mailto: enquiries@e2v.com

e2v sas

16 Burospace
F-91572 Bièvres Cedex
France

Tel: +33 (0) 16019 5500

Fax: +33 (0) 16019 5529

mailto: enquiries-fr@e2v.com

e2v aerospace and defense inc

765 Sycamore Drive
Milpitas

California 95035

USA

Tel: +1 408 737 0992

Fax: +1 408 736 8708

mailto: enquiries-na@e2v.com

Americas

e2v inc

520 White Plains Road
Suite 450 Tarrytown, NY 10591
USA

Tel: +1 (914) 592 6050 or 1-800-342-5338,

Fax: +1 (914) 592-5148

mailto: enquiries-na@e2v.com

Asia Pacific

e2v ltd

11th floor
Onfem Tower
29 Wyndham Street
Central, Hong Kong

Tel: +852 3679 3648 or +852 3679 3649

Fax: +852 3583 1084

mailto: enquiries-ap@e2v.com

Product Contact:

e2v

4 Avenue de Rochepleine
BP 123 - 38521 Saint-Egrève Cedex
France

Tel: +33 (0)4 76 58 30 00

Hotline:

mailto: hotline-bdc@e2v.com

Whilst e2v has taken care to ensure the accuracy of the information contained herein it accepts no responsibility for the consequences of any use thereof and also reserves the right to change the specification of goods without notice. e2v accepts no liability beyond that set out in its standard conditions of sale in respect of infringement of third party patents arising from the use of tubes or other devices in accordance with information contained herein.

Users of e2v products are responsible for their own products and applications.

e2v technologies does not assume liability for application support and assistance.

e2v technologies reserves the right to modify, make corrections, improvements and other changes to its products and services at any time and to discontinue any product without notice. Customers are advised to obtain the latest relevant information prior to placing orders and should verify that such information is current and complete.

