

EXAMINED BY : <i>Jony Chen</i>	MITSUTECH INTERNATIONAL CORPORATION	FILE NO . CAS-10010
APPROVED BY: <i>David Chang</i>		ISSUE : SEP.20,1999
		TOTAL PAGE : 9
		VERSION : 3

CUSTOMER

ACCEPTANCE

SPECIFICATIONS

MODEL NO . :
12A00(REFLECTIVE TYPES)
FOR MESSRS :

CUSTOMER'S APPROVAL

DATE :

BY :

MITSUTECH INT'L CORP.

MODEL NO .

VERSION

12A00(REFLECTIVE TYPES)

3

RECORDS OF REVISION		DOC . FIRST ISSUE	OCT.22,1997
DATE	REVISED PAGE NO.	SUMMARY	
NOV.11,1998	2	3.2 ENVIRONMENTAL ABSOLUTE MAXIMUM RATINGS AMBIENT TEMPERATURE : OPERATING FOR W.T. : 60°C MAX.→ 70°C MAX. STORAGE FOR W.T. : 70°C MAX.→80°C MAX.	
	3	4. ELECTRICAL CHARACTERISTICS RECOMMENDED LCD DRIVING VOLTAGE : VDD-VO W.T. : Ta=60°C →Ta=70°C	
	5	6. OPTICAL CHARACTERISTICS RESPONSE TIME W.T. : Ta=60°C →Ta=70°C	
SEP.20,1999	2,3,5	THE ENTIRE PAGES REVISED	

MITSUTECH INT'L CORP.

MODEL NO .

12A00(REFLECTIVE TYPES)

VERSION

3

TABLE OF CONTENTS

NO.	ITEM	PAGE
1.	GENERAL SPECIFICATIONS -----	1
2.	MECHANICAL SPECIFICATIONS -----	1
3.	ABSOLUTE MAXIMUM RATINGS -----	2
4.	ELECTRICAL CHARACTERISTICS -----	3
5.	TIMING CHARACTERISTICS -----	4
6.	OPTICAL CHARACTERISTICS -----	5
7.	OUTLINE DIMENSION -----	6
8.	DETAIL DRAWING OF DOT MATRIX -----	7
9.	POWER SUPPLY -----	7
10.	BLOCK DIAGRAM -----	8
11.	INTERFACE SIGNALS -----	9

MITSUTECH INT'L CORP.

MODEL NO.	VERSION
12A00 (REFLECTIVE TYPES)	3

NUMBERING SYSTEM

Polarizer Mode	Backlight	Code value
Reflective	—	R

E W 1 2 A 0 0 G R

LCD type + color	Code Value
STN + Yellow-Green	Y
STN + Gray	G
FSTN + White	F

MITSUTECH INT'L CORP.

MODEL NO .

VERSION

PAGE

12A00(REFLECTIVE TYPES)

3

1

1. GENERAL SPECIFICATIONS

1.1 GENERAL SPECIFICATIONS

PLEASE REFER TO :

CUSTOMER ACCEPTANCE STANDARD SPECIFICATIONS :

E U - 0 0 2 A

1.2 APPLICATION NOTES FOR CONTROLLER / DRIVER :

PLEASE REFER TO :

CUSTOMER ACCEPTANCE STANDARD SPECIFICATIONS :

E U - S E D 1 5 2 0 D 0 A

1.3 THIS INDIVIDUAL SPECIFICATIONS IS PRIOR TO GENERAL SPECIFICATIONS .

2. MECHANICAL SPECIFICATIONS

- | | | |
|--------------------|-------|----------------------------------|
| (1) NUMBER OF DOTS | ----- | 122 * 32 DOTS |
| (2) MODULE SIZE | ----- | 69.2W * 31.75H * 8.0D (MAX.) mm |
| (3) EFFECTIVE AREA | ----- | 57.2W * 17.2H mm |
| (4) ACTIVE AREA | ----- | 52.41W * 13.71H mm |
| (5) DOT SIZE | ----- | 0.38W * 0.38H mm |
| (6) DOT PITCH | ----- | 0.43W * 0.43H mm |
| (7) LCD TYPE * | | |
| (8) DRIVING METHOD | ----- | 1 / 32 DUTY MULTIPLEX DRIVER |

* PLEASE REFER TO NUMBERING SYSTEM

MITSUTECH INT'L CORP.

MODEL NO .

VERSION

PAGE

12A00(REFLECTIVE TYPES)

3

2

3. ABSOLUTE MAXIMUM RATINGS

3.1 ELECTRICAL ABSOLUTE MAXIMUM RATINGS . (AT Ta = 25 °C)

PARAMETER	SYMBOL	MIN .	MAX .	UNIT	REMARK
SUPPLY VOLTAGE FOR LOGIC	VDD-VSS	0	8.0	V	
INPUT VOLTAGE	VI	VSS	VDD	V	
STATIC ELECTRICITY	—	—	100	V	NOTE (1)

NOTE (1) : TEST METHOD AND CONDITIONS :
 AFTER CHARGING UP 200 PF CAPACITOR BY STATED VOLTAGE ,
 THE CAPACITOR IS CONNECTED WITH INTERFACE PINS OF THE
 MODULE .

3.2 ENVIRONMENTAL ABSOLUTE MAXIMUM RATINGS .

I T E M	OPERATING		STORAGE		REMARK
	MIN .	MAX .	MIN .	MAX .	
AMBIENT TEMPERATURE	- 20 °C	70 °C	- 30°C	80 °C	
HUMIDITY	—	90 % RH	—	90 % RH	WITHOUT CONDENSATION
VIBRATION	—	4.9 m/s ² (0.5 G)	—	19.6 m/s ² (2 G)	
SHOCK	—	29.4 m/s ² (3 G)	—	490.0 m/s ² (50 G)	XYZ DIRECTIONS
CORROSIVE GAS	NOT ACCEPTABLE		NOT ACCEPTABLE		

NOTE (2) : Ta AT -30°C : 48HR MAX .
 80°C : 168HR MAX .

NOTE (3) : BACKGROUND COLOR CHANGES SLIGHTLY DEPENDING ON AMBIENT
 TEMPERATURE THIS PHENOMENON IS REVERSIBLE .

4 . ELECTRICAL CHARACTERISTICS

PARAMETERM		SYMBOL	CONDITION	MIN .	TYP .	MAX .	UNIT
POWER SUPPLY VOLTAGE	RECOMMENDED	VDDVSS	—	4.5	5.0	5.5	V
	ALLOWABLE	VDDVSS	—	2.4	—	7.0	V
HIGH LEVEL INPUT VOLTAGE	FOR TTL	VIHT	NOTE (1)	2.0	—	VDD	V
	FOR CMOS	VIHC	NOTE (2)	4.0	—	VDD	V
LOW LEVEL INPUT VOLTAGE	FOR TTL	VILT	NOTE (1)	0	—	0.8	V
	FOR CMOS	VILC	NOTE (2)	0	—	1.0	V
HIGH LEVEL OUTPUT VOLTAGE	FOR TTL	VOHT	IOH= -3.0 mA NOTE (3)	2.4	—	—	V
LOW LEVEL OUTPUT VOLTAGE	FOR TTL	VOLT	IOL= 3.0 mA NOTE (3)	—	—	0.4	V
POWER SUPPLY CURRENT (INCLUDE DC TO DC CONVERTER)		IDD	VDD-VSS=5V	—	2.5	—	mA
LCD DISPLAY DUTY RATIO		DUTY	—	—	32	—	—
OSCILLATION FREQUENCY	f OSC		VDD = 5.0 V RF = 1.0M Ω	15	18	21	KHZ
			VDD = 3.0 V RF = 1.0M Ω	11	16	21	KHZ
RESET TIME		t R	—	1.0	—	1000	uS
RECOMMENDED LCD DRIVING VOLTAGE	VDD - VO	∅ = 10° θ = 0°	Ta = -20°C	—	5.5	—	V
			Ta = 25°C	—	5.5	—	V
			Ta = 70°C	—	5.2	—	V

NOTE (1) : APPLIED TO TERMINALS A0 , DB0 ~ DB7 , E , R / W .

NOTE (2) : APPLIED TO TERMINALS RES .

NOTE (3) : APPLIED TO TERMINALS DB0~DB7

NOTE (4) : RECOMMENDED LCD DRIVING VOLTGE MAY FLUCTUATE ABOUT
± 0.5V BY EACH MODULE .

5. TIMING CHARACTERISTICS

MPU BUS READ/WRITE (68-FAMILY MPU)

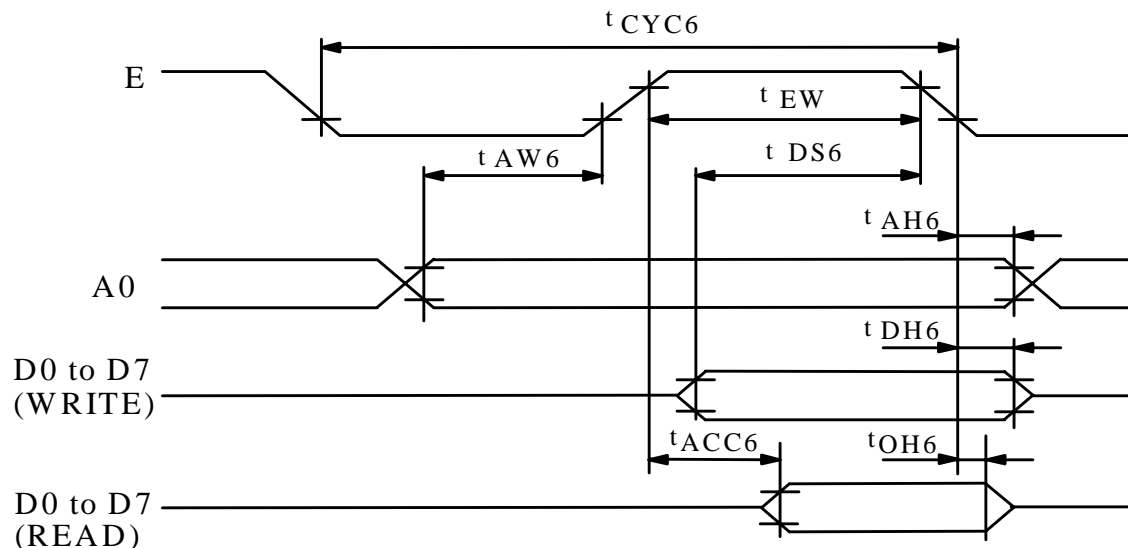

PARAMETER	SYMBOL	CONDITION	RATING		UNIT	SIGNAL
SYSTEM CYCLE TIME	t_{CYC6}		1000	—	ns	A0
ADDRESS SETUP TIME	t_{AW6}		20	—	ns	
ADDRESS HOLD TIME	t_{AH6}		10	—	ns	
DATA SETUP TIME	t_{DS6}		80	—	ns	D0 TOD7
DATA HOLD TIME	t_{DH6}		10	—	ns	
OUTPUT DISABLE TIME	t_{OH6}	CL=100PF	10	60	ns	
ACCESS TIME	t_{ACC6}		—	90	ns	
ENABLE	READ	t_{EW}	100	—	ns	E
PULSEWIDTH	WRITE		8	—	ns	

NOTES:

- t_{CYC6} IS THE CYCLE TIME OF CS. E=H,NOT THE CYCLE TIME OF E.
- INCREASE PARAMETER VALUES BY 200% THEN VDD=3.0V.
- ALL INPUTS MUST HAVE A RISE AND FALL TIME OF LESS THAN 15ns.

MITSUTECH INT'L CORP.

MODEL NO .

VERSION

PAGE

12A00(REFLECTIVE TYPES)

3

5

6. OPTICAL CHARACTERISTICS

Ta = 25 °C

VDD = 5.0 V

VDD-V0 = 5.5 V

I T E M		SYMBOL	CONDITION	MIN .	TYP .	MAX.	UNIT	NOTE
VIEWING AREA	STN	∅ 2 - ∅ 1	K ≥ 1.4	40	—	—	deg.	1
	FSTN			50	—	—	deg.	1
CONTRAST RATIO	STN	K	∅ = 10° θ = 0°	—	5	—	—	1
	FSTN			5	—	—	—	1
REPOSE TIME	tr (rise)	∅ = 10° θ = 0°	Ta = -20°C	—	5538	—	ms	1
			Ta = 25°C	—	228	—		
			Ta = 70°C	—	104	—		
	tf (fall)		Ta = -20°C	—	2316	—		
			Ta = 25°C	—	174	—		
			Ta = 70°C	—	85	—		

NOTE (1) : PLEASE REFER TO :

CUSTOMER ACCEPTANCE STANDARD SPECIFICATIONS.

E U - 002 A

MODEL NO.	VERSION	PAGE
12A00(REFLECTIVE TYPES)	3	6

7. OUTLINE DIMENSION

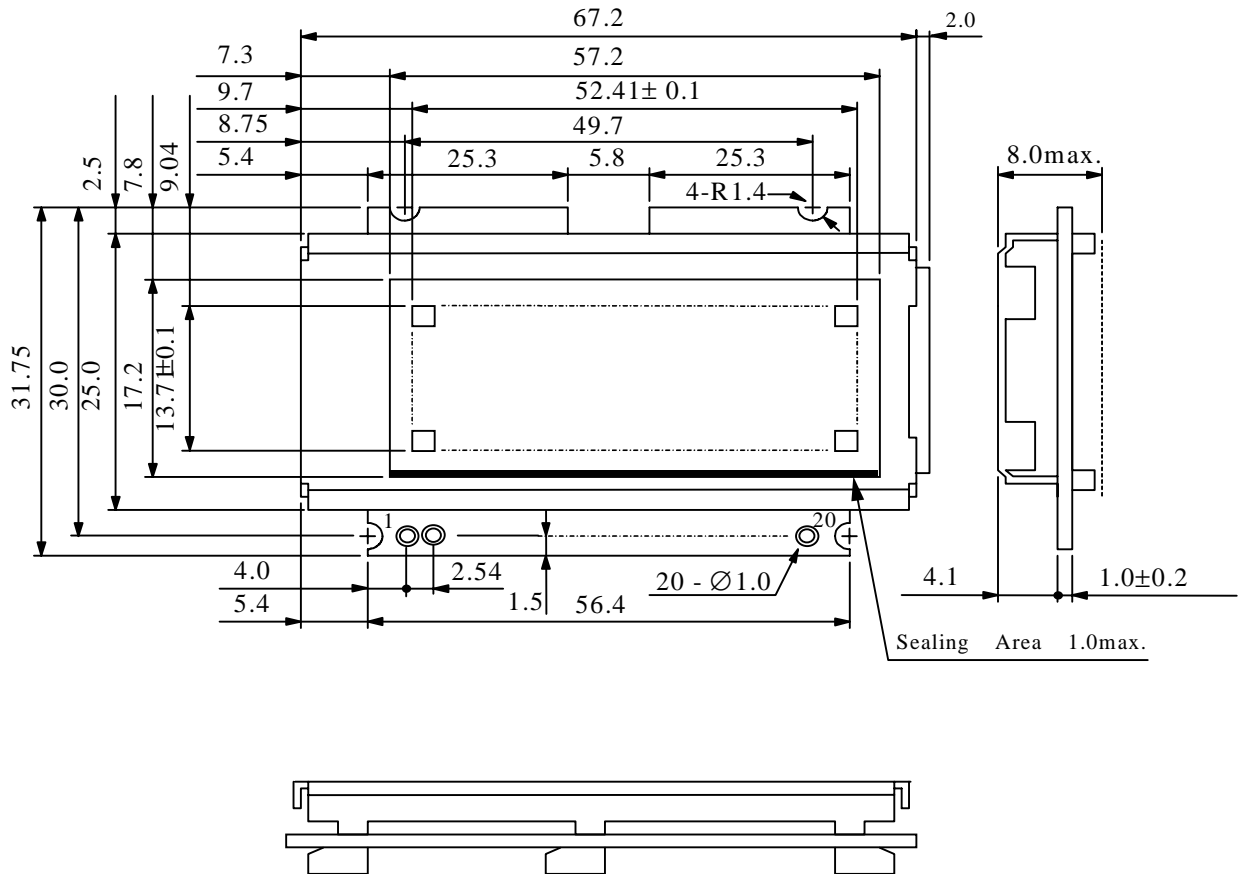

UNIT : mm
 SCALE : NTS
 NOT SPECIFIED TOLERANCE IS ± 0.3 mm

MODEL NO . 12A00(REFLECTIVE TYPES)	VERSION 3	PAGE 7
---------------------------------------	--------------	-----------

8. DETAIL DRAWING OF DOT MATRIX

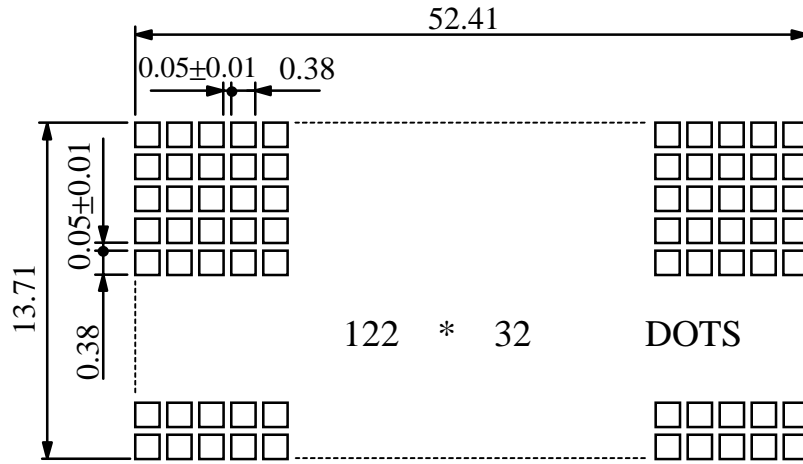

UNIT : mm
SCALE : NTS
NOT SPECIFIED TOLERANCE IS±0.1

9. POWER SUPPLY

9.1 POWER SUPPLY FOR LCM

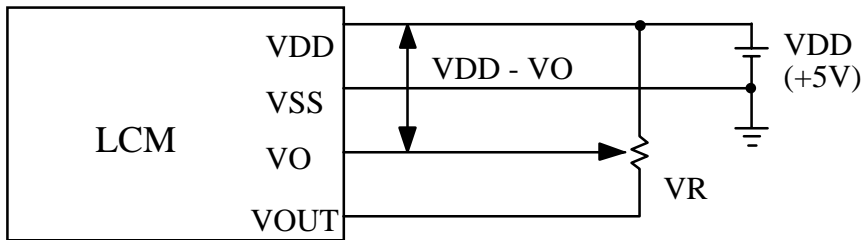

VDD-VO : LCD DRIVING VOLTAGE

VR : 10KΩ~20KΩ

MODEL NO .	VERSION	PAGE
12A00(REFLECTIVE TYPES)	3	8

10. BLOCK DIAGRAM

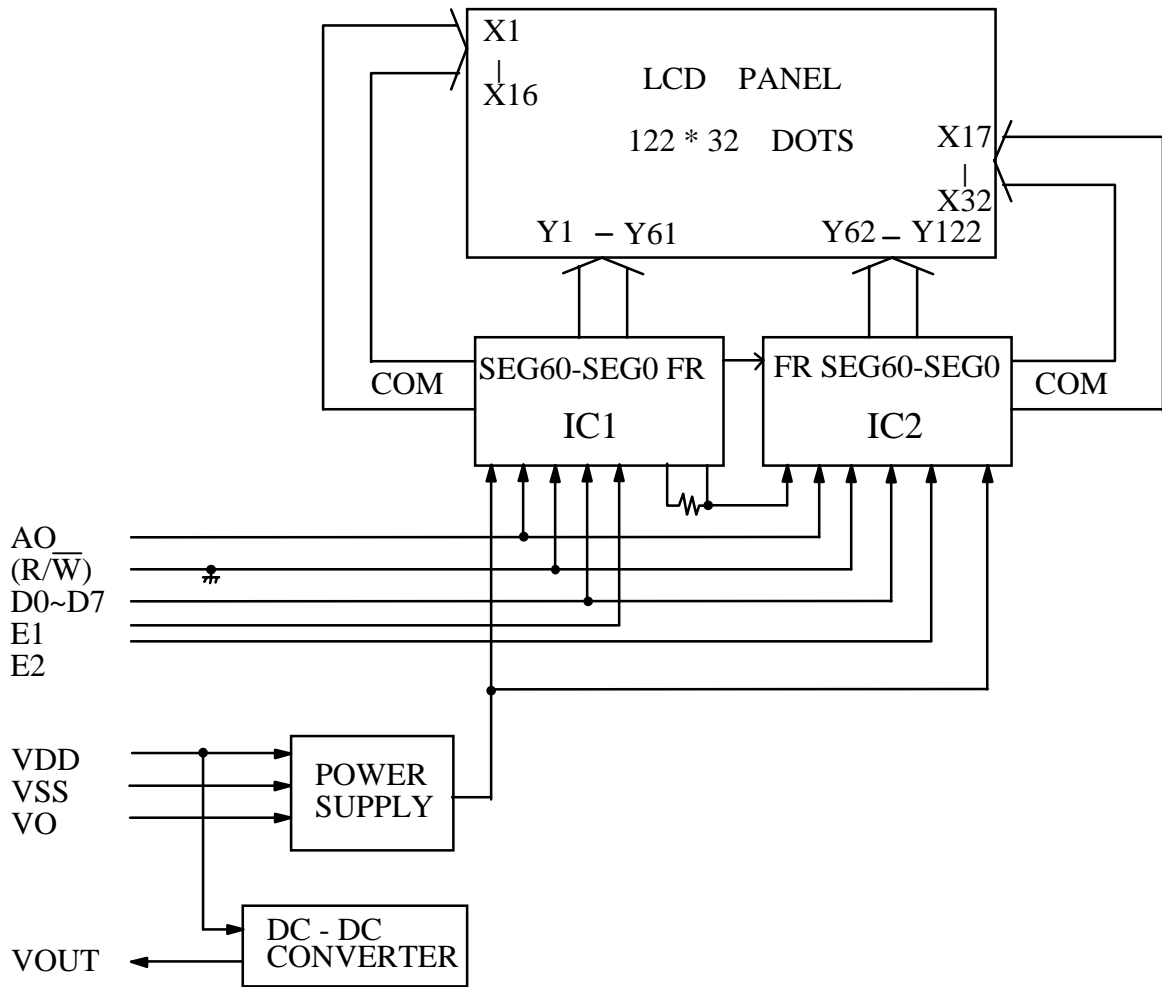

11. INTERFACE SIGNALS .

PIN NO .	SYMBOL	DESCRIPTION
1	VSS	GROUND (0V)
2	VDD	POWER SUPPLY FOR LOGIC CIRCUIT
3	V0	OPERATING VOLTAGE FOR LCD DRIVING
4	VOUT	POWER SUPPLY FOR LCD DRIVING (GENERATED BY DC - DC , -5V)
5	A0	DATA/COMMAND SELECT INPUT A0 = 0 : COMMAND A0 = 1 : DATA
6	E1	ENABLE CLOCK INPUT FOR IC1
7	E2	ENABLE CLOCK INPUT FOR IC2
8	DB0	TRI - STATE , BI - DIRECTIONAL I/O BUS
9	DB1	TRI - STATE , BI - DIRECTIONAL I/O BUS
10	NC	NO CONNECTION
11	NC	NO CONNECTION
12	DB2	TRI - STATE , BI - DIRECTIONAL I/O BUS
13	DB3	TRI - STATE , BI - DIRECTIONAL I/O BUS
14	DB4	TRI - STATE , BI - DIRECTIONAL I/O BUS
15	DB5	TRI - STATE , BI - DIRECTIONAL I/O BUS
16	DB6	TRI - STATE , BI - DIRECTIONAL I/O BUS
17	DB7	TRI - STATE , BI - DIRECTIONAL I/O BUS
18	NC	NO CONNECTION
19	NC	_____
20	NC	_____