

EXAMINED BY: Bob	EMERGING DISPLAY	FILE NO . CAS-10248
APPROVED BY: Roger Yang		ISSUE : APR.09,2002
	TECHNOLOGIES CORPORATION	TOTAL PAGE : 8
		VERSION : 2

CUSTOMER

ACCEPTANCE

SPECIFICATIONS

MODEL NO. :

32FA2(LED TYPES)

FOR MESSRS :

CUSTOMER'S APPROVAL

DATE :

BY :

EMERGING DISPLAY
TECHNOLOGIES CORPORATION

MODEL NO. 32FA2(LED TYPES)	VERSION 2
--------------------------------------	---------------------

RECORDS OF REVISION	DOC . FIRST ISSUE MAY.24,2001
----------------------------	----------------------------------

DATE	REVISED PAGE NO.	SUMMARY																																																			
APR.09,2002	2	3. ABSOLUTE MAXIMUM RATINGS VR7 - VSS → VEE - VSS DELETE : NOTE (2)																																																			
	3	4. ELECTRICAL CHARACTERISTICS <table border="1"> <thead> <tr> <th>PARAMETER</th> <th>SYMBOL</th> <th>CONDITION</th> <th>MIN.</th> <th>TYP.</th> <th>MAX.</th> <th>UNIT</th> </tr> </thead> <tbody> <tr> <td>RECOMMENDED</td> <td>VEE - VSS</td> <td>Ta = -20 °C</td> <td>—</td> <td>24.2</td> <td>—</td> <td>V</td> </tr> <tr> <td rowspan="2">LCD DRIVING RESISTER VALUE NOTE (3)</td> <td rowspan="2">$\phi = 10^\circ \theta = 0^\circ$ DUTY = 1/240</td> <td>Ta = 25 °C</td> <td>—</td> <td>21.7</td> <td>—</td> <td>V</td> </tr> <tr> <td>Ta = 60 °C</td> <td>—</td> <td>18.2</td> <td>—</td> <td>V</td> </tr> </tbody> </table> <table border="1"> <thead> <tr> <th>PARAMETER</th> <th>SYMBOL</th> <th>CONDITION</th> <th>MIN.</th> <th>TYP.</th> <th>MAX.</th> <th>UNIT</th> </tr> </thead> <tbody> <tr> <td>RECOMMENDED</td> <td>VEE - VSS</td> <td>Ta = -20 °C</td> <td>23.2</td> <td>24.2</td> <td>25.2</td> <td>V</td> </tr> <tr> <td rowspan="2">LCD DRIVING VOLTAGE</td> <td rowspan="2">$\phi = 10^\circ \theta = 0^\circ$ DUTY = 1/240</td> <td>Ta = 25 °C</td> <td>20.7</td> <td>21.7</td> <td>22.7</td> <td>V</td> </tr> <tr> <td>Ta = 60 °C</td> <td>17.2</td> <td>18.2</td> <td>19.2</td> <td>V</td> </tr> </tbody> </table> DELETE : NOTE (3)	PARAMETER	SYMBOL	CONDITION	MIN.	TYP.	MAX.	UNIT	RECOMMENDED	VEE - VSS	Ta = -20 °C	—	24.2	—	V	LCD DRIVING RESISTER VALUE NOTE (3)	$\phi = 10^\circ \theta = 0^\circ$ DUTY = 1/240	Ta = 25 °C	—	21.7	—	V	Ta = 60 °C	—	18.2	—	V	PARAMETER	SYMBOL	CONDITION	MIN.	TYP.	MAX.	UNIT	RECOMMENDED	VEE - VSS	Ta = -20 °C	23.2	24.2	25.2	V	LCD DRIVING VOLTAGE	$\phi = 10^\circ \theta = 0^\circ$ DUTY = 1/240	Ta = 25 °C	20.7	21.7	22.7	V	Ta = 60 °C	17.2	18.2	19.2
PARAMETER	SYMBOL	CONDITION	MIN.	TYP.	MAX.	UNIT																																															
RECOMMENDED	VEE - VSS	Ta = -20 °C	—	24.2	—	V																																															
LCD DRIVING RESISTER VALUE NOTE (3)	$\phi = 10^\circ \theta = 0^\circ$ DUTY = 1/240	Ta = 25 °C	—	21.7	—	V																																															
		Ta = 60 °C	—	18.2	—	V																																															
PARAMETER	SYMBOL	CONDITION	MIN.	TYP.	MAX.	UNIT																																															
RECOMMENDED	VEE - VSS	Ta = -20 °C	23.2	24.2	25.2	V																																															
LCD DRIVING VOLTAGE	$\phi = 10^\circ \theta = 0^\circ$ DUTY = 1/240	Ta = 25 °C	20.7	21.7	22.7	V																																															
		Ta = 60 °C	17.2	18.2	19.2	V																																															
JUN.03,2002	3	4. ELECTRICAL CHARACTERISTICS VEE - VSS : - 20 °C ~ 60 °C → - 10 °C ~ 60 °C																																																			

NUMBERING SYSTEM

Polarizer Mode	Backlight	Code value
Transflective	LED	L
Transmissive	LED	M

E W 3 2 F A 2 F L W

LCD type + color	Code Value
FSTN + White	F
STN + Blue	B
FSTN + Black	N

Backlight	Code value
WHITE	W

TABLE OF CONTENTS

NO.	ITEM	PAGE
1.	GENERAL SPECIFICATIONS -----	1
2.	MECHANICAL SPECIFICATIONS -----	1
3.	ABSOLUTE MAXIMUM RATINGS -----	2
4.	ELECTRICAL CHARACTERISTICS -----	3
5.	OPTICAL CHARACTERISTICS -----	4
6.	OUTLINE DIMENSION -----	5
7.	BLOCK DIAGRAM -----	6
8.	DETAIL DRAWING OF DOT MATRIX -----	7
9.	INTERFACE SIGNALS -----	7, 8
10.	POWER SUPPLY -----	8

1. GENERAL SPECIFICATIONS

1.1 GENERAL SPECIFICATIONS

PLEASE REFER TO :

CUSTOMER ACCEPTANCE STANDARD SPECIFICATIONS :

EU - 002A

1.2 THIS INDIVIDUAL SPECIFICATIONS IS PRIOR TO GENERAL SPECIFICATIONS .

1.3 TOUCH PANEL SPECIFICATIONS PLEASE REFER TO :

EU - SED 1335

2. MECHANICAL SPECIFICATIONS

(1) NUMBER OF DOTS	-----	320W * 240H DOTS
(2) MODULE SIZE	-----	126.2W * 99.8H * 9.3 D (max.) mm
(3) EFFECTIVE AREA	-----	77.79W * 58.59H mm
(4) ACTIVE AREA	-----	76.79W * 57.59H mm
(5) DOT SIZE	-----	0.23W * 0.23H mm
(6) DOT PITCH	-----	0.24W * 0.24H mm
(7) LCD TYPE *		
(8) DRIVING METHOD	-----	1 / 240 DUTY MULTIPLEX DRIVE
(9) VIEWING DIRECTION	-----	6 O'CLOCK
(10) BACK LIGHT	-----	LED;COLOR : WHITE

* PLEASE REFER TO NUMBERING SYSTEM .

3. ABSOLUTE MAXIMUM RATINGS

3.1 ELECTRICAL ABSOLUTE MAXIMUM RATINGS .

PARAMETER	SYMBOL	MIN .	MAX .	UNIT	REMARK
POWER SUPPLY FOR LOGIC	VDD – VSS	2.7	5.5	V	
POWER SUPPLY FOR LCD DRIVING	VEE – VSS	—	27V	V	NOTE (2)
INPUT VOLTAGE	VI	VSS	VDD	V	
STATIC ELECTRICITY	—	—	100	V	NOTE (1)
POWER SUPPLY FOR LED	VLED – VLSS	—	5	V	

NOTE (1) : TEST METHOD AND CONDITIONS :
AFTER CHARGING UP 200 PF CAPACITOR BY STATED VOLTAGE ,
THE CAPACITOR IS CONNECTED WITH INTERFACE PINS OF THE
MODULE .

3.2 ENVIRONMENTAL ABSOLUTE MAXIMUM RATINGS .

I T E M	OPERATING		STORAGE		REMARK
	MIN .	MAX .	MIN .	MAX .	
AMBIENT TEMPERATURE	-10 °C	60 °C	-20 °C	70 °C	NOTE (2), (3)
HUMIDITY	—	85 % RH	—	85 % RH	WITHOUT CONDENSATION
VIBRATION	—	2.45 m/s ² (0.25 G)	—	11.76 m/s ² (1.2 G)	10~100 HZ XYZ DIRECTIONS 1 Hr. EACH
SHOCK	—	29.4 m/s ² (3 G)	—	490.0 m/s ² (50 G)	10 mSECONDS XYZ DIRECTIONS 1 TIME EACH
CORROSIVE GAS	NOT ACCEPTABLE		NOT ACCEPTABLE		

NOTE (2) : Ta AT -20°C : 48HR MAX.
60°C : 168HR MAX.

NOTE (3) : BACKGROUND COLOR CHANGES SLIGHTLY DEPENDING ON AMBIENT
TEMPERATURE THIS PHENOMENON IS REVERSIBLE .

4. ELECTRICAL CHARACTERISTICS

Ta = 25 °C

VDD-VSS = 5.0 V

PARAMETER	SYMBOL	CONDITION	MIN.	TYP.	MAX.	UNIT
POWER SUPPLY VOLTAGE FOR LOGIC	VDD - VSS	—	2.7	—	5.0	V
INPUT VOLTAGE NOTE (1)	VIH	H LEVEL	0.5*VDD	—	—	V
	VIL	L LEVEL	—	—	0.2*VDD	V
OUTPUT VOLTAGE NOTE (1)	VOH	H LEVEL	2.4	—	—	V
	VOL	L LEVEL	—	—	VSS+0.4	V
POWER SUPPLY CURRENT FOR LOGIC NOTE (2)	IDD	VDD - VSS = 5.0 V VEE - VSS = 21.7V	—	16.0	—	mA
POWER SUPPLY CURRENT FOR LCD DRIVE NOTE (2)	IEE	VDD - VSS = 5.0 V VEE - VSS = 21.7V	—	6.0	—	mA
RECOMMENDED LCD DRIVING VOLTAGE	VEE - VSS ∅ = 10° θ = 0° DUTY = 1/240	Ta = -10 °C	23.2	24.2	25.2	V
		Ta = 25 °C	20.7	21.7	22.7	V
		Ta = 60 °C	17.2	18.2	19.2	V
CLOCK OSCILLATION FREQUENCY	f _{osc}	—	—	8	—	MHZ
POWER SUPPLY FOR LED	VLED - VLSS	IF = 100 mA	—	5	—	V

NOTE (1): APPLIED TO TERMINALS D0 TO D7, A0, \overline{CS} , \overline{RD} , \overline{WR} .

NOTE (2): THE DISPLAY PATTERN IS ALL "OFF" / "ON".

5. OPTICAL CHARACTERISTICS

Ta = 25 °C

I T E M		SYMBOL	CONDITION	MIN.	TYP.	MAX.	UNIT	NOTE
VIEWING AREA	STN	$\varnothing 2 - \varnothing 1$	$K \geq 2.0$	—	40	—	deg.	1
	FSTN			50	—	—	deg.	1
CONTRAST RATIO	STN	K	$\varnothing = 10^\circ$	3	—	—	—	1
	FSTN			5	—	—	—	1
RESPONSE TIME		tr (rise)	$\varnothing = 10^\circ$ $\theta = 0^\circ$	—	(330)	—	msec	1
		tf (fall)	$\varnothing = 10^\circ$ $\theta = 0^\circ$	—	(330)	—	msec	1
THE BRIGHTNESS OF BACK-LIGHT		B	$\varnothing = 10^\circ$ $\theta = 0^\circ$	10	—	—	cd/m ²	1, 2
				13	—	—		1, 3

NOTE (1) : PLEASE REFER TO :
CUSTOMER ACCEPTANCE STANDARD SPECIFICATIONS. (EU - 002A)

NOTE (2) : POLARIZER IS TRANSFLECTIVE TYPE .

NOTE (3) : POLARIZER IS TRANSMISSIVE TYPE .

6. OUTLINE DIMENSION

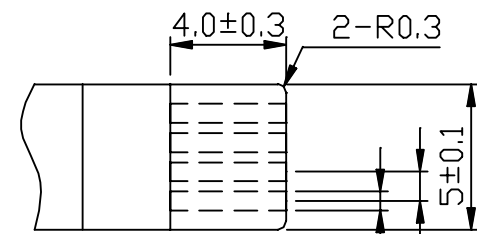
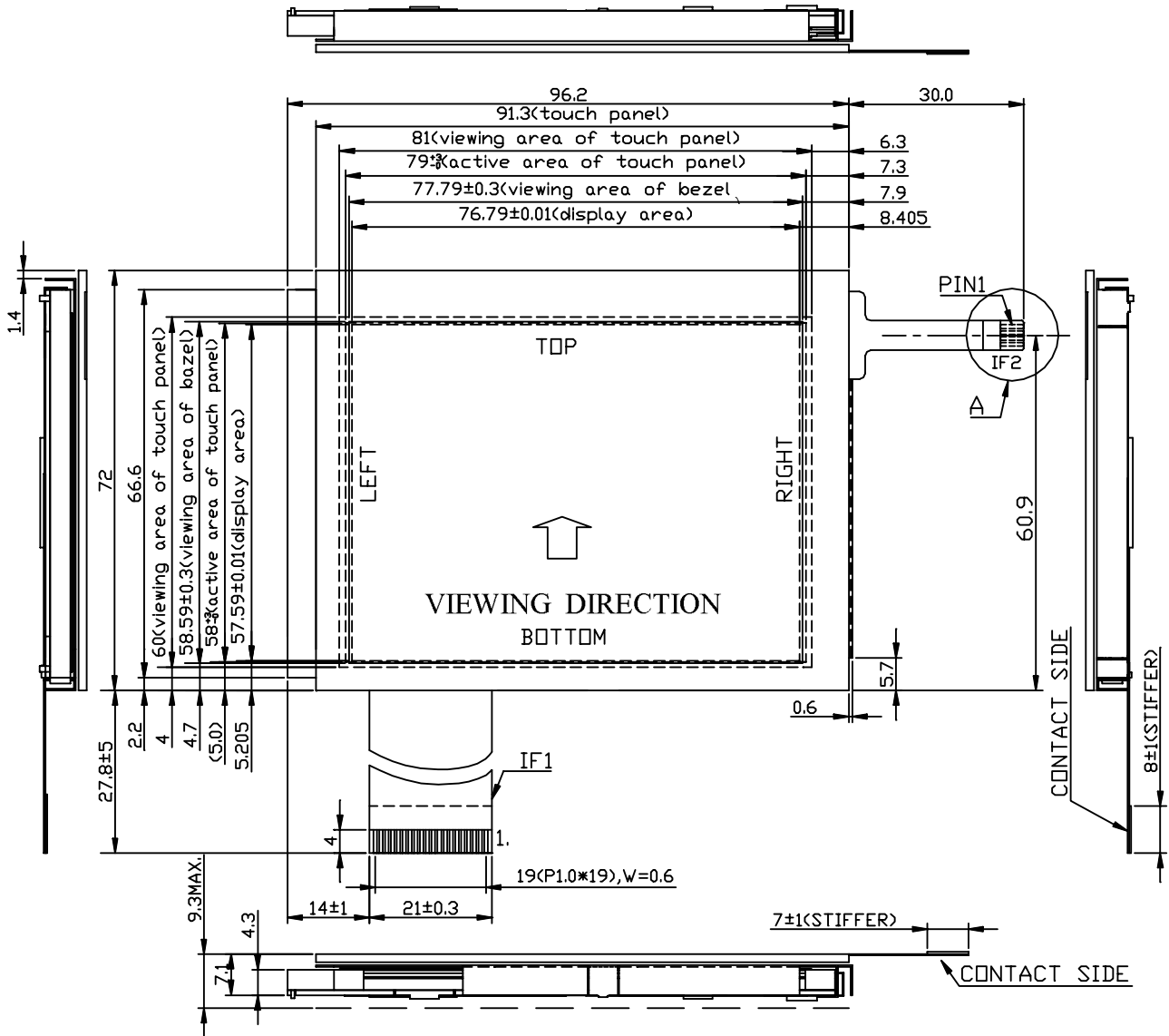

→ FEMALE CONNECTOR OF MOLEX P/N. 52271-0491 IS RECOMMENDED

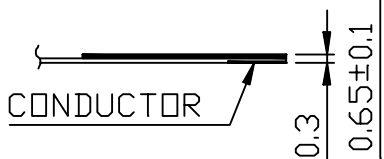

A DETAIL

UNIT : mm
SCALE : NTS
NOT SPECIFIED TOLERANCE IS ±0.5

7. BLOCK DIAGRAM

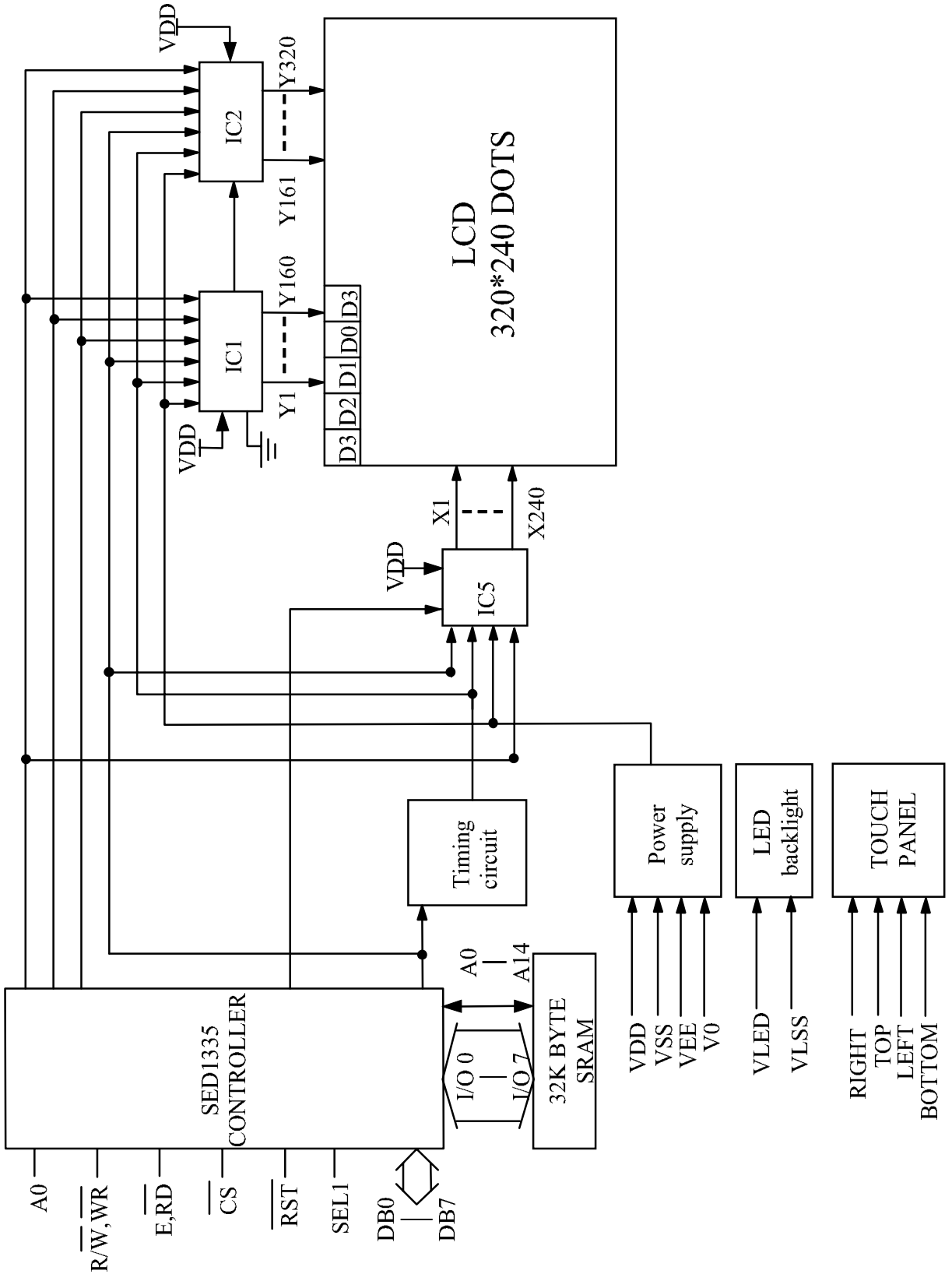

8. DETAIL DRAWING OF DOT MATRIX

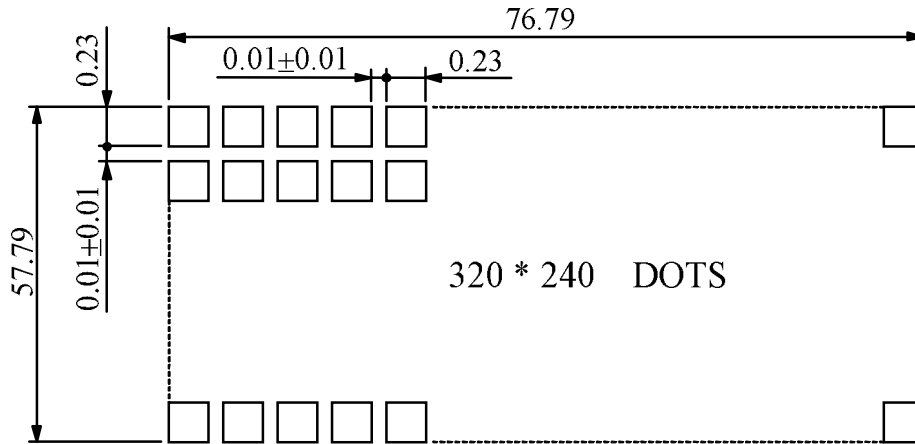

UNIT : mm
SCALE : NTS
NOT SPECIFIED TOLERANCE IS ± 0.1

9. INTERFACE SIGNALS

IF1:

PIN NO	SYMBOL	LEVEL	FUNCTION																				
1	VSS	—	GROUND																				
2	VDD	—	POWER SUPPLY FOR LOGIC CIRCUIT																				
3	N.C	—	N.C.																				
4	A0	—	8080 FAMILY INTERFACE																				
			<table border="1"> <thead> <tr> <th>AO</th> <th>\overline{RD}</th> <th>\overline{WR}</th> <th>FUNCTION</th> </tr> </thead> <tbody> <tr> <td>0</td> <td>0</td> <td>1</td> <td>STATUS FLAG READ</td> </tr> <tr> <td>1</td> <td>0</td> <td>1</td> <td>DISPLAY DATA AND CURSOR ADDRESS READ</td> </tr> <tr> <td>0</td> <td>1</td> <td>0</td> <td>DISPLAY DATA AND PARAMETER WRITE</td> </tr> <tr> <td>1</td> <td>1</td> <td>0</td> <td>COMMAND WRITE</td> </tr> </tbody> </table>	AO	\overline{RD}	\overline{WR}	FUNCTION	0	0	1	STATUS FLAG READ	1	0	1	DISPLAY DATA AND CURSOR ADDRESS READ	0	1	0	DISPLAY DATA AND PARAMETER WRITE	1	1	0	COMMAND WRITE
			AO	\overline{RD}	\overline{WR}	FUNCTION																	
			0	0	1	STATUS FLAG READ																	
			1	0	1	DISPLAY DATA AND CURSOR ADDRESS READ																	
			0	1	0	DISPLAY DATA AND PARAMETER WRITE																	
			1	1	0	COMMAND WRITE																	
			6800 FAMILY INTERFACE																				
			<table border="1"> <thead> <tr> <th>AO</th> <th>R/W</th> <th>E</th> <th>FUNCTION</th> </tr> </thead> <tbody> <tr> <td>0</td> <td>1</td> <td>1</td> <td>STATUS FLAG READ</td> </tr> <tr> <td>1</td> <td>1</td> <td>1</td> <td>DISPLAY DATA AND CURSOR ADDRESS READ</td> </tr> <tr> <td>0</td> <td>0</td> <td>1</td> <td>DISPLAY DATA AND PARAMETER WRITE</td> </tr> <tr> <td>1</td> <td>0</td> <td>1</td> <td>COMMAND WRITE</td> </tr> </tbody> </table>	AO	R/W	E	FUNCTION	0	1	1	STATUS FLAG READ	1	1	1	DISPLAY DATA AND CURSOR ADDRESS READ	0	0	1	DISPLAY DATA AND PARAMETER WRITE	1	0	1	COMMAND WRITE
			AO	R/W	E	FUNCTION																	
0	1	1	STATUS FLAG READ																				
1	1	1	DISPLAY DATA AND CURSOR ADDRESS READ																				
0	0	1	DISPLAY DATA AND PARAMETER WRITE																				
1	0	1	COMMAND WRITE																				
5	$\overline{WR}, R/\overline{W}$	H/L	8080 FAMILY INTERFACE ACTS AS THE ACTIVE-LOW WRITE STROBE . 6800 FAMILY INTERFACE ACTS AS THE READ/ WRITE CONTROL SIGNAL .																				
6	\overline{RD}, E	H/L	8080 FAMILY INTERFACE ACTS AS THE ACTIVE-LOW READ STROBE . 6800 FAMILY INTERFACE ACTS AS THE ACTIVE-HIGH ENABLE CLOCK																				

7	D0		H/L DISPLAY DATA
14	D7		
15	\overline{CS}	H/L	CHIP SELECT
16	\overline{RST}	H/L	RESET
17	VEE	—	CONNECTION RESISTER TO GND (FOR CONTRST ADJUST)
18	SEL1	H/L	8080 OR 6800 FAMILY INTERFACE SELECT , NC OR H:6800 , L:8080
19	VLED	—	POWER SUPPLY FOR LED B.L
20	VLSS	—	POWER SUPPLY FOR LED B.L

IF2:

PIN NO	SYMBOL	LEVEL	FUNCTION
1	LEFT	—	LEFT SIDE
2	TOP	—	TOP
3	RIGHT	—	RIGHT SIDE
4	BOTTOM	—	BOTTOM

10. POWER SUPPLY

10.1 POWER SUPPLY FOR LCM

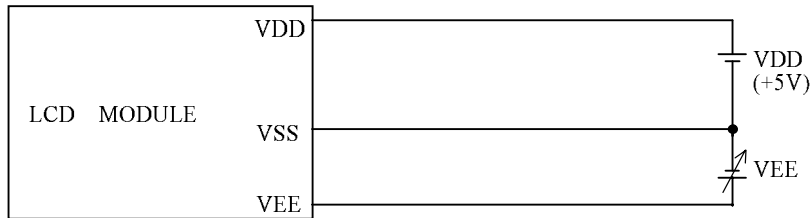

VEE - VSS : LCD DRIVING VOLTAGE

10.2 POWER SUPPLY FOR LED BACK - LIGHT

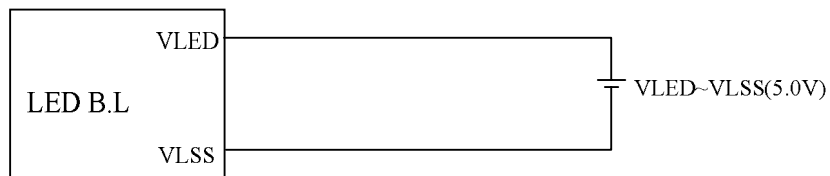

10.3 TIMING OF POWER SUPPLY AND INTERFACE SIGNAL

