

EXB-8205 and EXB-8505 Cartridge Tape Subsystem

Standard and and eXtended length configurations

Installation and Operation

Copyright

Copyright 1993-1994 by Exabyte Corporation. All rights reserved. This item and the information contained herein are the property of Exabyte Corporation. No part of this document may be reproduced, transmitted, transcribed, stored in a retrieval system, or translated into any language or computer language in any form or by any means, electronic, mechanical, magnetic, optical, chemical, manual, or otherwise, without the express written permission of EXABYTE Corporation, 1685 38th Street, Boulder, Colorado 80301.

Disclaimer

EXABYTE Corporation makes no representation or warranties with respect to the contents of this document and specifically disclaims any implied warranties of merchantability or fitness for any particular purpose. Further, EXABYTE Corporation reserves the right to revise this publication without obligation to notify any person or organization of such revisions or changes.

Trademark Notices

AMP is a trademark of AMP Incorporated. Beckman Industrial is a trademark of Emerson Electric Company. Dale is a registered trademark of Dale Electronics, Inc. dataMate is a registered trademark of Methode Electronics, Inc. EXABYTE is a registered trademark and EXATAPE is a trademark of Exabyte Corporation. Molex is a registered trademark of Molex Incorporated. All other product names are trademarks or registered trademarks of their respective companies.

Revision History

Revision	Date	Description
000	August 1993	Initial release
001	May 1994	Updated to add information about the eXtended-Length (XL) tape drives and the 160m XL 8mm tape

EXABYTE Corporation
 1685 38th Street
 Boulder, CO 80303
 Phone: (303) 442-4333
 Fax: (303)442-7170

302967-001

Product Warranty Caution

The EXB-8205, EXB-8205XL, EXB-8505, and EXB-8505XL 8mm Cartridge Tape Subsystems (tape drives) are warranted to be free from defects in materials, parts, and workmanship and will conform to the current product specifications upon delivery. **For the specific details of your warranty, refer to your sales contract or contact the company from which the tape drive was purchased.**

The warranty for the tape drive shall not apply to failures caused by:

- Physical abuse or use not consistent with the operating instructions or product specifications provided by Exabyte's personnel or agent for the applicable equipment.
- Modifications by other than Exabyte's personnel or agent in any way other than those approved by Exabyte, provided the warranty shall not be voided by the repair or replacement of parts or the attachment of items in the manner described in maintenance or installation instructions provided by Exabyte.
- Repair by other than Exabyte's personnel or agent in a manner contrary to the maintenance instructions provided by Exabyte.
- Removal of the Exabyte serial number tag.
- Physical abuse due to improper packaging of returns.

CAUTION

Returning the tape drive in unauthorized packaging may damage the unit and void the warranty. Refer to the packing instructions in this book for information.

If problems with the tape drive occur, contact your maintenance organization; do not void the product warranty by allowing untrained or unauthorized personnel to attempt repairs.

Contents

Welcome	5
About This Guide	6
Conventions Used in This Guide	6
For More Information	6
1 Installing the tape drive	7
Unpacking and Handling the tape drive	8
Setting the SCSI ID	9
Preparing the Tape Drive for the SCSI Bus	11
Installing the Tape Drive in a Computer	13
Performing the Initial Power On	18
2 Operating the tape drive	20
Selecting Data Cartridges	23
Setting the Write-Protect Switch on a Data Cartridge	25
Loading a Data Cartridge in the tape drive	26
Unloading a Data Cartridge	27
3 Preventive Maintenance	28
Determining When to Clean the Tape Drive	28
Using the 8mm Cleaning Cartridge	29
Caring for Data Cartridges	30
4 Shipping the Tape Drive	32
Packing the Tape Drive	33
Environmental Requirements for Shipment	35
Appendix A Installation Requirements	36
SCSI Cable	36
SCSI Connector	37
Power Supply	38
Power Connector	38
Attaching the tape drive to a Frame	39
Chassis Grounding (Optional)	41
Appendix B Unload Button Options	42
Appendix C Tape Drive Specifications	44
Index	45

WELCOME

Thank you for selecting the Exabyte® EXB-8205, EXB-8205XL, EXB-8505, or EXB-8505XL 8mm Cartridge Tape Subsystem (tape drive). These tape drives are high-capacity, high-performance, and highly reliable storage devices for PC, workstation, and local area network (LAN) applications.

The “eXtended-Length” (XL) configurations of the tape drives (EXB-8205XL and EXB-8505XL) provide additional capacity by supporting the extended-length EXATAPE™ 160m XL 8mm Data Cartridge. Information about the 160m XL data cartridge is provided on page 24.

EXB-8505 and EXB-8505XL

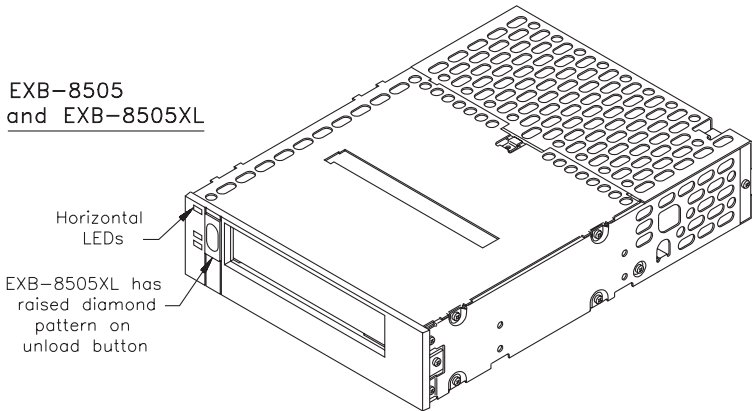

EXB-8205 and EXB-8205XL

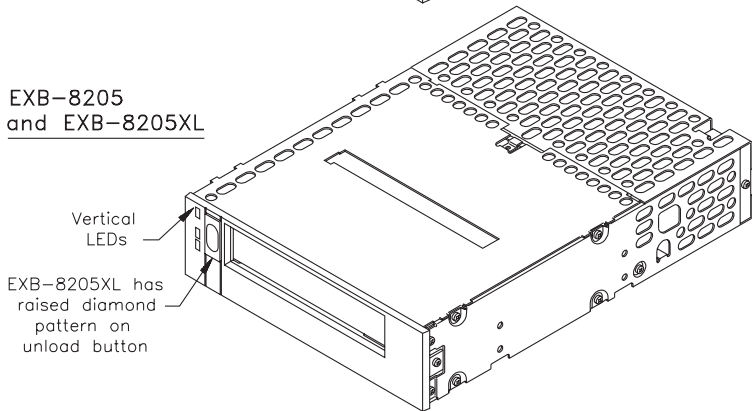

About This Guide

Use this guide as you install and operate the tape drive. In addition to instructions for installation and operation, this guide provides information about selecting and maintaining data cartridges, cleaning the tape drive, and packing the tape drive for shipment.

Conventions Used in This Guide

Special information is highlighted as follows:

Note: *Notes* provide hints or suggestions about the topic or procedure being discussed.

Important

Information in *Important* boxes will help you successfully complete a procedure or avoid additional steps in a procedure.

CAUTION

Information in *Caution* boxes explains how to avoid damaging the tape drive, the data cartridge, other equipment, or data recorded on tape.

For More Information

For tape drive specifications, refer to the EXB-8205 and EXB-8505 Product Specification for Standard and eXtended-Length Configurations (510504). For information about programming SCSI commands for the tape drive, refer to the EXB-8205 and EXB-8505 SCSI Reference for Standard and eXtended-Length Configurations (510503). For information about integrating the tape drive into a host system, refer to *EXB-8205 and EXB-8505 Integration and Optimization for Standard and eXtended-Length Configurations (510505)*.

1 Installing the tape drive

This section provides instructions for the following tasks:

- Unpacking and handling the tape drive (page 8)
- Setting the SCSI ID (page 9)
- Preparing the tape drive for the SCSI bus (page 11)
- Installing the tape drive in a computer (page 13)
- Performing the initial power on (page 18)

Table 1 lists the tools and equipment you will need.

Table 1 Tools and equipment for installing the tape drive

Required Tools and Equipment	
SCSI cable	See page 36 for SCSI cable requirements.
Power cable	See page 36 for power cable requirements.
Power supply	See pages 38-38 for power specifications.
Optional Tools and Equipment	
Remote switch or jumpers	If you use a remote switch, use a female Molex [®] 22-55-2061 (or equivalent) cable connector.
External SCSI bus terminator	Differential: If the tape drive terminates the SCSI bus, you must provide a Methode Electronics, Inc. dataMate [®] DM103-01-0 (or equivalent) differential external terminator. Single-ended: If the tape drive terminates the SCSI bus, you have the option of removing the tape drive's internal terminators (R-packs) and using a dataMate DM103-02-0 (or equivalent) single-ended external terminator.
Mounting frame or brackets, four M3 5 6 mm screws, screwdriver	Depending on your installation requirements, can be used to mount the tape drive.
Flat-nose wiring pliers	Can be used to remove the R-packs from a single-ended tape drive that uses an external terminator or does not terminate the SCSI bus.
1/4-inch female spade connector or M3-0.5 6 mm self-tapping screw	Can be used for additional chassis grounding.

Unpacking and Handling the tape drive

The tape drive's packaging is designed to protect the tape drive from shock, vibration, moisture, and electrostatic discharge (ESD). Save all original packaging in case you need to repack or ship the tape drive.

If the temperature of the room in which you are unpacking the tape drive varies from the storage location by 15° C (27° F) or more, let the tape drive acclimate in its packaging to the unpacking environment for at least 12 hours before opening the box.

After you unpack the tape drive, check the contents of the carton against the packing list and inspect the tape drive for possible damage. If a part is missing or the tape drive is damaged, notify the carrier and your vendor immediately.

Note: If the tape drive has been stored for more than six months, follow the instructions on page 18 when applying power for the first time. (Check the MLCH label on the top of the tape drive to find out when the tape drive was manufactured.)

CAUTION

Follow these procedures to protect the tape drive from electrostatic discharge:

- Leave the tape drive in its antistatic bag until you are ready to install it.
- Use an antistatic mat and grounded static protection wristband. If a mat and wristband are unavailable, discharge static electricity from your body before handling the tape drive. (Touch a known grounded surface, such as your computer's metal chassis.)
- If you must lay the tape drive down, place it into or on top of the antistatic bag.

Setting the SCSI ID

After you have unpacked the tape drive, you can set the tape drive's SCSI ID. You can use either of the following methods:

- Attach jumpers (shunts) to the pins on the tape drive's SCSI ID jumper block. Jumpers are already installed on the jumper block when the tape drive is shipped.
- Connect a remote switch to the SCSI ID jumper block on the back of the tape drive.

Setting the SCSI ID with Jumpers

To set the SCSI ID using jumpers, follow these steps:

1. Locate the SCSI ID jumper block on the back of the tape drive, as shown in Figure 1.

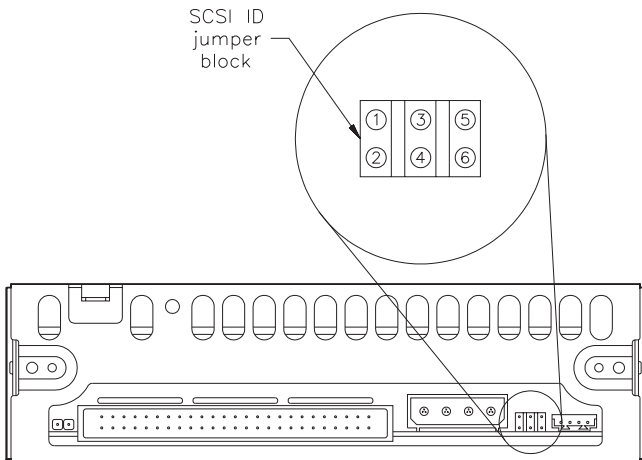

Figure 1 SCSI ID jumper block on the back of the tape drive

2. Remove the jumpers from the jumper block to obtain the correct address for your configuration. Figure 2 shows how to position the jumpers for addresses 0 through 7.

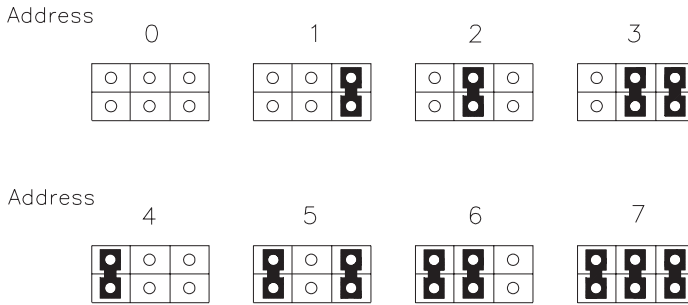

Figure 2 Jumper settings for the tape drive's SCSI ID

Setting the SCSI ID with a Remote Switch

If you want to set the SCSI ID remotely, you can attach a remote switch assembly (not provided with the tape drive) to the tape drive's SCSI ID jumper block. To set the SCSI ID with a remote switch, follow these steps:

1. Locate the SCSI ID jumper block on the back of the tape drive, as shown in Figure 1.
2. If necessary, remove the jumpers from the pins.
3. Connect a remote switch to the jumper block. Ensure that the remote switch is no more than 30.5 cm (12 inches) from the jumper block.
4. Change the settings on the remote switch to the correct address for your configuration. The switch settings should emulate the jumper positions shown in Figure 2.

Note: For specific information about pin assignments for the SCSI ID jumper block, refer to the *EXB-8205 and EXB-8505 Product Specification* for the tape drive.

Preparing the Tape Drive for the SCSI Bus

The SCSI bus that you attach the tape drive to must be terminated correctly to ensure proper operation. The devices that are physically located at each end of the SCSI cable must have terminators installed. All other devices on the SCSI cable must not have terminators installed.

If you place the tape drive at the end of the SCSI bus, you must terminate the tape drive. The procedure you use depends on whether the tape drive uses a single-ended or a differential SCSI configuration.

Termination for a Single-Ended tape drive

The single-ended tape drive includes three single in-line package (SIP) resistor terminators (R-packs) that can be left in place if the tape drive terminates the SCSI bus.

CAUTION

The R-packs must be removed if the tape drive does not terminate the SCSI bus or if external SCSI bus termination will be used. Instructions for removing the R-packs are provided below.

Optional External Termination

If desired, you can terminate the single-ended tape drive externally by removing the R-packs from the back of the tape drive and installing an external terminator. Exabyte recommends a Methode Electronics, Inc. dataMate DM103-02-0 single-ended external terminator.

Removing the R-Packs

To remove the R-packs, follow these steps:

1. Locate the three R-packs on the back of the tape drive, as shown in Figure 3.
2. Using a pair of flat-nose wiring pliers, grasp each R-pack in the center and pull it straight out. Be careful not to squeeze the pliers too tightly or you may break the R-pack.

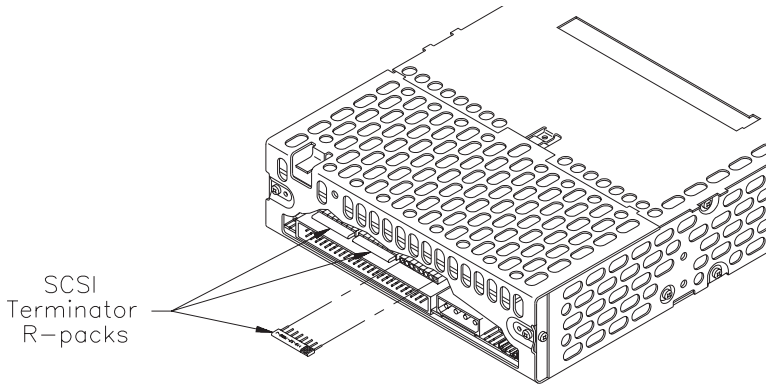

Figure 3 Location of R-packs on the back of the tape drive (single-ended configuration)

Replacing the R-Packs

If you need to put the R-packs back in the tape drive, make sure that pin 1 of each R-pack is aligned with pin 1 of the socket and that no pins are bent. As shown in Figure 3, the writing on the R-pack should face upward. Pin 1 of the R-pack is marked with a colored line or dot and should line up with the right side of the socket.

CAUTION

If you replace an R-pack, be sure to use the correct type to avoid damaging the tape drive. Use an 8-pin, 6-resistor SIP terminator, rated at 220/330 ohms. Exabyte recommends either of the following terminators (or equivalent):

- Dale®: part number CSC 08A-05-221/331J
- Beckman Industrial™: part number L08-5C221/331J

Termination for a Differential tape drive

The differential tape drive does not include internal terminators. If a differential tape drive terminates the SCSI bus, it must be terminated externally. See page 7 for information about the recommended terminator.

Connecting the SCSI Cable

After removing or installing terminators as required, connect the SCSI cable to the SCSI connector on the back of the tape drive. The connector is keyed so that it can be connected only one way.

Figure 4 shows the location of the SCSI connector. See Appendix A starting on page 36 for information about the requirements for the SCSI cable.

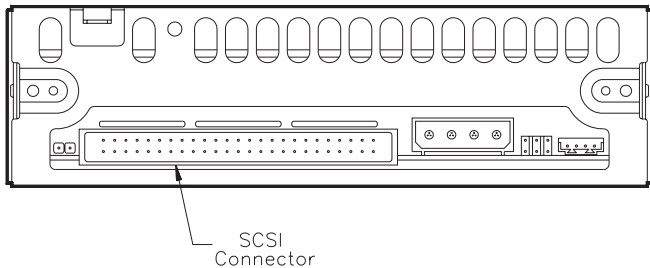

Figure 4 Location of SCSI connector

Installing the Tape Drive in a Computer

If you are installing the tape drive in a drive bay in a computer system, follow the guidelines in this section. Otherwise, refer to Appendix A for general installation requirements. Then, turn to page 18 to perform the initial power on.

Preparing the Computer System

Before installing the tape drive in your computer system, prepare the system as follows:

1. Turn off the computer and any attached devices.
2. Unplug the computer's power cord.
3. Remove the computer's cover as described in your computer system documentation.

4. If there is a cover plate over the drive bay you plan to use, remove it. Refer to your computer system documentation for instructions. Keep any screws or mounting clips; you may need them to secure the tape drive to the drive bay.

Note: If necessary, remove a floppy disk drive to provide an empty half-high drive bay for the tape drive. Refer to your computer system documentation for instructions. Do not replace your floppy drive A with the tape drive.

Important

If you remove a floppy disk drive to install the tape drive, be sure to change your system configuration files to reflect the change. Refer to your computer system documentation for instructions.

Installation Procedure

Follow these steps to install the tape drive in the drive bay:

1. Check for the presence of a load resistor in your computer. If it is present, disconnect the load resistor cable from the power supply. Refer to your computer system documentation for more information.
2. Use #6 32 screws to attach two slide rails to the sides of the tape drive as shown in Figure 5. You can use rails that are provided with your computer system or purchase rails from Exabyte or your computer supplier.

Note: If there is more than one set of mounting holes in the rails, use whichever set allows you to position the tape drive flush with the front of the drive bay.

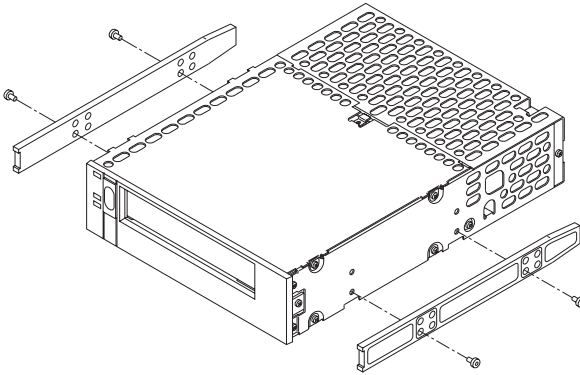

Figure 5 Attaching slide rails to the tape drive

3. From the front of the computer, thread the SCSI cable through the open drive bay, as shown in Figure 6. Slide the tape drive into the bay until the front of the drive is flush with the front of the drive bay.
4. Connect the SCSI cable to the SCSI adapter card in your computer.

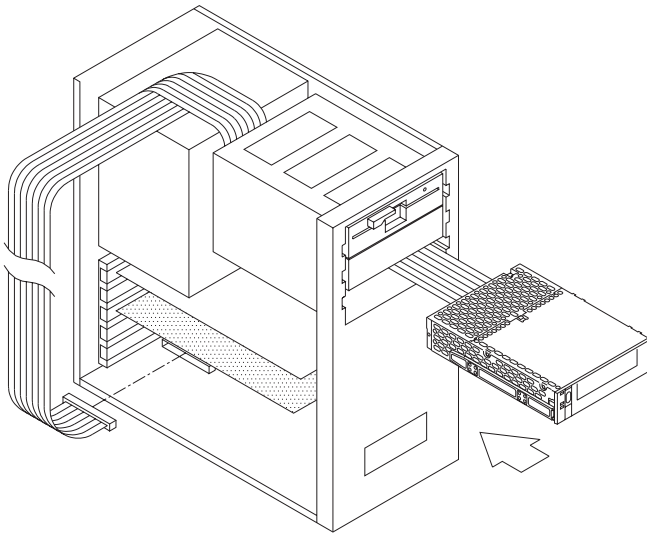

Figure 6 Inserting the drive into the drive bay and connecting the SCSI cable to the adapter card

5. Slide the tape drive into the drive bay and secure the drive to the bay as instructed in your computer system documentation.
6. If you needed additional chassis grounding, connect a 1/4-inch female spade connector to the ground tab at the rear of the tape drive. Or, connect an M3-0.5 6 mm self-tapping screw to the grounding hole. The ground tab and grounding hole are shown in Figure 7.

Note: The power supply returns are connected to the chassis, so you cannot isolate logic common ground from chassis ground.

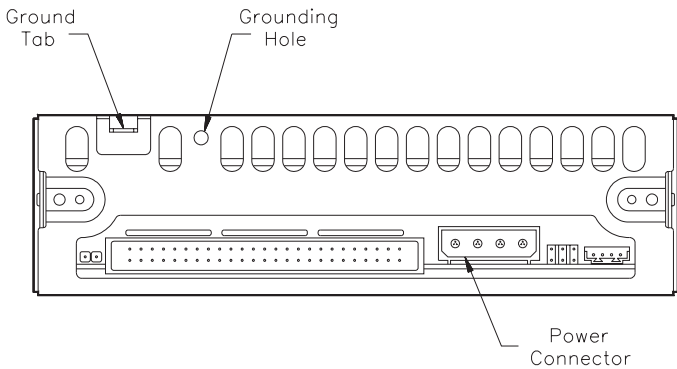

Figure 7 Location of ground tab, grounding hole, and power connector on the back of the CTS

7. Locate the power connector on the back of the tape drive. Connect the power cable to the power connector as shown in Figure 8.

CAUTION

The power cable plug and the power connector are keyed so they can fit together in only one way. Before connecting the plug to the tape drive, be sure that the beveled edges of the plug are oriented in the same way as the beveled edges on the power connector. Do not force the plug into the connector or you may damage the tape drive.

8. Replace the cover on your computer.

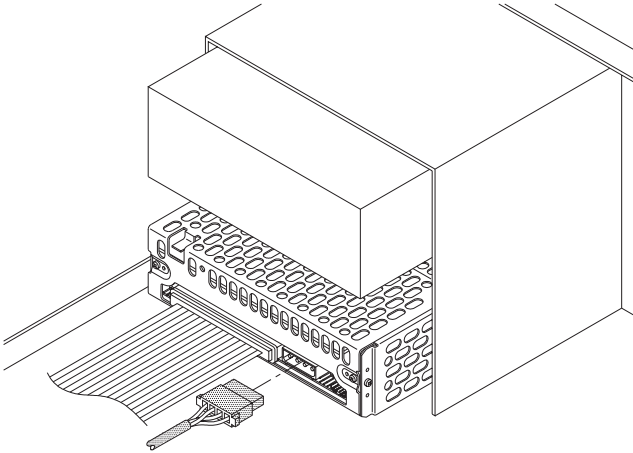

Figure 8 Connecting the power cable to the tape drive

Performing the Initial Power On

The procedure you use to perform the initial power on depends on how long the tape drive has been stored. If you are not sure how long the tape drive has been stored, check the MLCH (machine level control history) label on the top of the tape drive to find out when the tape drive was manufactured. Although the tape drive may have been operated since it was manufactured, for the purpose of the initial power on, assume that it has been stored throughout this period.

Tape Drive Stored for Less Than Six Months

If the tape drive has been stored for less than six months, the only step you need to perform for the initial power-on is to apply power to the tape drive.

When power is applied, the tape drive performs its power-on initialization and self-test (POST). Assuming that no data cartridge is loaded and that the tape drive is connected correctly, POST takes about 32 seconds, as follows:

- During the first part of POST, all three LEDs are lit.
- During the second part of POST, the top LED is lit and the middle and bottom LEDs may flash, depending on whether the tape drive is connected to the SCSI bus and a data cartridge is loaded.

When POST completes (top LED off), the tape drive is ready for normal operation.

Important

- Do not insert a data cartridge into the tape drive while POST is occurring. The tape drive will eject it.
- If the top LED does not go out after POST, an error has occurred. Contact your vendor.

Tape Drive Stored for Six Months or More

If the tape drive has been stored for six months or more, perform the following steps using your backup software to ensure that the tape drive's internal lubrication is properly distributed:

1. Apply power to the tape drive. The tape drive performs its POST as described on page 18.
2. Locate a test tape and ensure that the write-protect switch is set to permit data to be written to the tape (see page 25).
3. Insert the data cartridge into the tape drive with the label side up and the write-protect switch facing you.
4. Wait while the tape drive loads the tape and positions it to the logical beginning of tape (LBOT). This takes about 40 seconds. When the bottom LED is on solid, the tape drive is ready.
5. Perform a backup operation to write approximately 500 MB of data to the tape.
6. Rewind the tape and read the data written in step 5.
7. Repeat steps 5 and 6 at least two times or for two hours (whichever is greater).

Note: If errors occur, reset the tape drive and repeat steps 5 through 7 as appropriate.

When you have completed step 7, the tape drive is ready for normal operation.

2 Operating the tape drive

This section includes information about the following:

- Reading the LEDs
- Selecting data cartridges
- Setting the write-protect switch on the data cartridge
- Loading and unloading a data cartridge

Figure 9 shows the controls and indicators on the front panel of the EXB-8505. (Note that the front panel of the EXB-8205 is the same except the LEDs are vertical. The XL drives are the same as the non-XL drives except that they have a raised diamond pattern on the unload button.)

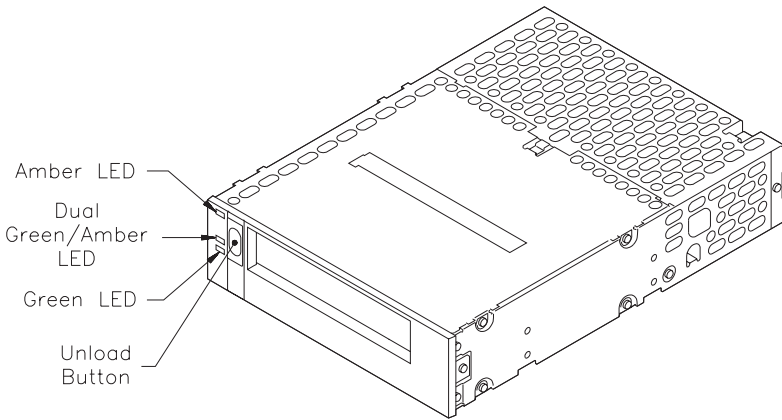

Figure 9 Unload button and LEDs on the tape drive's front panel

Reading the LEDs

The tape drive uses three LEDs to indicate its operating states. The LEDs indicate the following general conditions:

- **When the top (amber) LED is flashing**, the tape drive has an error or needs to be cleaned.
- **When the middle LED is on or flashing**, SCSI bus activity is occurring. The middle LED can be green or amber, as follows:
 - Amber:** The tape loaded in the tape drive is in one of the compression formats (8500c or 8200c). Note that when the tape is in 8500c format, the LED is always amber even though compression can be turned off.
 - Green:** The tape loaded in the tape drive is in one of the non-compression formats (8500 or 8200).
- **When the bottom (green) LED is on**, a data cartridge is loaded in the tape drive. When this LED is flashing, tape motion is occurring.

Table 2 shows specific combinations of LEDs that may occur during tape drive operation.

Note: You may occasionally observe LED combinations and sequences not described in Table 2. These other combinations represent special or unusual conditions that are beyond the scope of this table. (For example, a fairly complex LED sequence occurs when you load new microcode from tape.)

Table 2 tape drive states indicated by the LEDs

LEDs	Tape Drive State									
	POST (start)	POST (end)	Failed POST	Ready (no tape loaded)	Ready (tape loaded)	Normal tape motion	High-speed tape motion	SCSI bus reset	Error	Time to Clean
● = On ○ = Off * = Flash^a										
Top (errors)	●	●	fast *	○	○	○	○	●	slow *	fast *
Middle (SCSI)^b	green ●	irreg. *	irreg. *	irreg. *	irreg. *	irreg. *	irreg. *	irreg. *	irreg. *	irreg. *
Bottom (motion)	●	○ ^c	○	○	●	slow *	fast *	●	○	fast *

^a Slow flash = 1 flash/second (0.94 Hz).

Fast flash = 4 flashes/second (3.76 Hz).

Irregular flash = variable rate depending on SCSI bus activity. If the tape drive is not connected to the SCSI bus, the LED will be off.

^b Green_8500 or 8200 format.

Amber_8500c or 8200c format.

^c If a tape is loaded, the bottom LED will flash slow and then fast during the second part of the power-on self-test.

Selecting Data Cartridges

By selecting high-quality data cartridges and storing them properly, you can expect a long shelf-life and optimal data integrity from your tapes. High quality tapes also help maintain tape drive reliability by minimizing wear on the recording heads.

Choosing High-Quality Data Cartridges

Available from Exabyte, EXATAPE™ 8mm Data Cartridges are formulated specifically for use in Exabyte products. EXATAPE data cartridges reduce head and tape path wear and have a shelf life exceeding 30 years when used according to recommendations.

Available in lengths of 15m, 54 m, 112m, and 160m (for the EXB-8205XL and EXB-8505XL only, as described on page24), **EXATAPE data cartridges are the only data cartridges recommended for use with all Exabyte products.**

CAUTION

Never use video-grade tape for data storage. Video-grade tape can be less accurate than data-grade tape when recording high-density data and more abrasive to tape drive recording heads. In particular, **Exabyte strongly discourages use of the following types of video-grade tapes:**

- ✗ Extended-length video tapes (such as 135-, 140-, and 150-minute tapes)
- ✗ Hi-8 metal particle (MP), metal evaporative (ME), or barium ferrite (BaFe) tapes

EXATAPE 160m XL 8mm Data Cartridges

The EXATAPE 160m XL 8mm Data Cartridge is intended for use in the EXB-8502XL and EXB-8505XL only. The 160m XL tape is equipped with a Recognition System stripe, located on the tape leader, that enables the XL tape drive to recognize the tape as data-quality metal-particle media. To prevent the use of inappropriate media, the EXB-8205XL and EXB-8505XL do not accept 160m tapes without the Recognition System stripe. If you attempt to load a 160m tape without this stripe, the XL tape drive automatically ejects it.

The EXB-8205 and EXB-8505 do not support the 160m XL tape. If you attempt to load any 160m data cartridge into an EXB-8205 or EXB-8505, the tape drive automatically ejects the cartridge.

CAUTION

Do not attempt to use the 160m XL Data Cartridge in the following Exabyte tape drives: EXB-8200, EXB-8200SX, EXB-8500, or EXB-8500c. Although these drives will accept the 160m XL cartridge, these cartridges are not supported by these drives and should not be used.

Compatibility of EXATAPE 8mm Data Cartridges

Table 3 summarizes the compatibility of EXATAPE 8mm Data Cartridges with Exabyte 8mm tape drives.

Table 3 Compatibility of EXATAPE 8mm Data Cartridges and

	EXATAPE 8mm Data Cartridge			
	15m	54m	112m	160m XL
EXB-8205 and EXB-8505	✓	✓	✓	Not supported (automatically ejected)
EXB-8205XL and EXB-8505XL	✓	✓	✓	✓
EXB-8200 and EXB-8200SX	✓	✓	✓	Not supported
EXB-8500 and EXB-8500c	✓	✓	✓	Not supported

Setting the Write-Protect Switch on a Data Cartridge

EXATAPE™ 8mm data cartridges are equipped with a write-protect switch, shown in Figure 10, to prevent data on the tape from being unintentionally overwritten.

Before loading a data cartridge in the tape drive, ensure that the write-protect switch is set correctly for the desired operation. You can use a ball-point pen or similar instrument to set the write-protect switch as follows:

- **To write protect the data cartridge**, move the write-protect switch away from the edge of the data cartridge. If the red tab is visible, the cartridge is write protected and cannot be written to or erased.
- **To write enable the data cartridge**, move the write-protect switch toward the edge of the data cartridge. If the red tab is not visible, the data cartridge is write enabled and can be written to or erased.

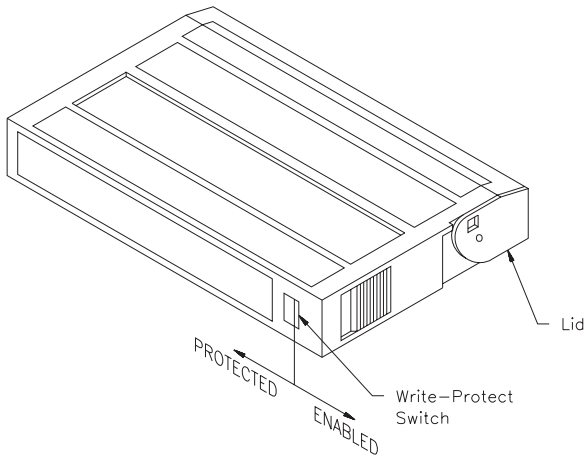

Figure 10 Write-protect switch on an EXATAPE 8mm data cartridge

Loading a Data Cartridge in the tape drive

Important

Exabyte strongly recommends that you use EXATAPE™ data-grade metal-particle media in the tape drive. Refer to page 23 for information about selecting appropriate tapes for your tape drive.

To load a data cartridge into the tape drive, follow these steps:

1. Ensure that the write-protect switch has been set correctly for the desired operation, as explained on page 25.
2. If you have just powered on the tape drive, be sure that the bottom and top LEDs are off, indicating that the tape drive has passed its power-on self-test and is ready to load the data cartridge.
3. Insert the data cartridge into the tape drive with the lid facing toward the tape drive, the write-protect switch facing away from the tape drive, and the label side of the cartridge facing the top of the tape drive.
4. The tape drive automatically loads the data cartridge and positions the tape to the logical beginning of tape (LBOT) within approximately 40 seconds (assuming that the data cartridge has already been rewound). During this period, the tape drive determines the tape format and the length of the tape. All three LEDs are off for the first 8 seconds of the load operation. Then, the bottom LED flashes to indicate tape motion. When the bottom LED is on solid, the tape drive is ready.

Note: If your application has disabled autoload, the tape drive will not go to the ready state until a LOAD (1Bh) command has been issued by your host system.

Unloading a Data Cartridge

The unload button is the only operator control on the tape drive. It is used to unload the tape from the tape drive. The unload button can also be used to clear servo and other errors. If a servo or hardware error occurs, press the unload button to reset the tape drive. Then, if necessary, wait a few seconds and press the button again to eject the tape.

Unload Procedure

To unload a data cartridge, press the unload button on the tape drive's front panel. The tape drive completes the current operation, writes any buffered data to the tape, rewinds the tape, unloads the tape from the tape path, and ejects the cartridge.

Notes:

- Some tape drives are configured to eject the tape immediately, without completing the current operation, when the unload button is pressed. Refer to Appendix B for more information about tape drives configured in this way.
- Some backup applications have features that prevent removal of the tape. In such cases, the tape drive performs no action when you press the unload button.

Error During Unload Procedure

If an error exists before or during the unload procedure, the unload sequence will be suspended and the top LED will flash. To clear the error, press the unload button again. The unload sequence will be reattempted; however, unwritten data in the buffer will not be written to tape. The buffer and errors will be cleared.

CAUTION

The first time you load a tape after resetting an unload error, use a test tape. Make sure that the tape drive can successfully unload the test tape before loading a tape containing valuable data.

3 Preventive Maintenance

The only routine maintenance required by the tape drive is regular cleaning of the tape drive's heads and tape path. The only cleaning material authorized for use with the tape drive is an Exabyte or Exabyte-approved 8mm Cleaning Cartridge. In addition, proper storage and maintenance of your data cartridges will maximize the shelf life of you tapes and ensure data integrity.

Important

Using a cleaning method other than the Exabyte 8mm Cleaning Cartridge or an Exabyte-approved cleaning cartridge will void the warranty for the tape drive and can lead to premature head wear.

Determining When to Clean the Tape Drive

You should clean the tape drive's heads and tape path either **once a month or after every 30 tape motion hours**, whichever occurs first. This cleaning frequency does not depend on the format in which you write and read data. However, if you are using the tape drive in a particularly dirty environment, or if you operate it infrequently, you may want to clean the tape drive more often.

The tape drive keeps track of its tape motion hours internally. When 30 tape motion hours have elapsed, the top and bottom LEDs will flash rapidly and the middle LED will flash irregularly, depending on SCSI bus activity. For best results, clean the tape drive as soon as possible after the LEDs begin flashing.

Note: Some backup software programs may use additional ways to notify you when the tape drive needs cleaning. Refer to the documentation for your backup software for more information.

Using the 8mm Cleaning Cartridge

Exabyte 8mm Cleaning Cartridges are available in two sizes: 3c and 12c. Used in the EXB-8205, EXB-8505, or XL tape drives, the 3c cleaning cartridge provides up to 9 cleanings. The 12c cleaning cartridge provides up to 36 cleanings.

Note: If you use these cleaning cartridges in an Exabyte full-high tape drive (EXB-8200, EXB-8200SX, EXB-8500, or EXB-8500c), you will get fewer cleaning passes per cartridge. These tape drives have longer tape paths than the EXB-8205, EXB-8505, or XL tape drives, and require more material for each cleaning.

CAUTION

To prevent contamination of the tape drive and damage to the heads, **never rewind and reuse the cleaning cartridge**. Reusing the material in the cleaning cartridge will redistribute contaminants previously removed from the tape path.

To use the cleaning cartridge, follow these steps:

1. Apply power to the tape drive. When the power-on self-test is complete, press the unload button and remove any data cartridge from the tape drive.
2. Insert the cleaning cartridge in the tape drive. The cleaning cycle is performed automatically by the tape drive and lasts from 2 to 3 minutes. When the cleaning cycle is complete, the cleaning cartridge is automatically unloaded and ejected.

Important

If there are no cleaning cycles remaining for the cleaning cartridge, the tape drive ejects it without performing the cleaning cycle. The top and bottom LEDs remain lit. Discard the cleaning cartridge when no more cleaning cycles remain.

3. To confirm that a cleaning was done, check the LEDs on the front panel. If the cleaning cycle was successful, the top and bottom LEDs will be off. If the cleaning cycle was not performed, the LEDs will continue to flash. Repeat the cleaning procedure with a new cleaning cartridge.
4. If the cleaning cycle was successful, you may want to keep a record of the date the cleaning was performed. Store the cleaning cartridge for future use if it still has cycles remaining. Or, discard it if no more cleaning cycles remain.

Caring for Data Cartridges

To maximize the shelf life of your tapes and assure data integrity, follow these guidelines when storing data cartridges:

- **Maintain the storage environment at a constant temperature and humidity.** A temperature within the range of +5°C to +32°C (+41°F to +90°F) with a relative humidity of 20% to 60% non-condensing is ideal for tape storage. Do not allow the temperature and humidity in the storage environment to fluctuate.
- **Keep the storage location as free of airborne particulates as possible.** To eliminate obvious sources of particulates, do not permit anyone to smoke, eat, or drink near the storage area, and do not store cartridges near a copier or printer that may emit toner and paper dust.
- **Store data cartridges as soon as possible after you have written data to them.** Immediate storage helps avoid many of the conditions that can damage tapes, such as temperature and humidity fluctuation, particulate contamination, and excessive handling.
- **Store data cartridges with the write-protect switch in the protected position.** Instructions for using the write-protect switch are provided on page 25.

- Store each cartridge on one of its long edges, not flat on its side (see Figure 11 on the following page). When a data cartridge is stored on its side, the tape inside the cartridge is actually on its edge. In this position, stress is placed on the tape edges and can lead to tape damage. For the same reason, never stack cartridges on top of each other or lean them at an angle for extended periods of time.

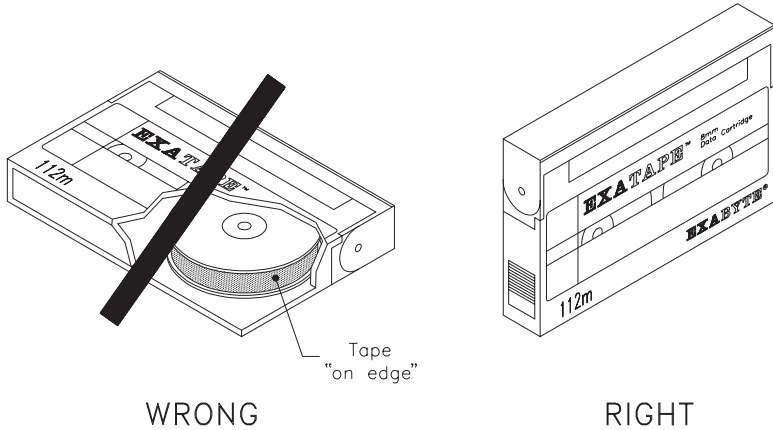

Figure 11 Do not store a data cartridge on its side

Replacing Data Cartridges

Approximately once each year, you may want to run each tape through a full pass and check its error statistics. If errors have increased significantly since the previous test or if they exceed a certain predetermined threshold, you should re-archive the data to a new tape and discard the old tape.

4 Shipping the Tape Drive

You can ship the tape drive with either one drive per carton (single-pack) or with three to five drives per carton (multi-pack). Figure 12 on page 34 shows the single-pack carton and packing materials; Figure 13 on page 35 shows the multi-pack carton and packing materials.

CAUTION

- To avoid damaging the tape drive and voiding your warranty, be sure to use the original shipping materials (or replacement materials obtained from Exabyte) when repacking and shipping the tape drive.
- To ensure that the packaging meets the required specifications, do not modify the packaging in any way. The shipping carton and packing materials are not intended to be used for shipping items other than or in addition to a tape drive.
- Do not use the multi-pack shipping carton for fewer than three tape drives. If you are shipping one or two tape drives, use a single-pack carton for each tape drive.

Table 4 shows the dimensions and weights of the single-pack and multi-pack shipping cartons.

Table 4 Dimensions and weights of tape drive shipping cartons

Size	Dimensions	Weight (with tape drive)
Single-pack	34.3 cm long 27.3 cm wide 15.5 cm high (13.5 10.75 6.12 inches)	1 drive: 1.9 kg (4.2 lbs)
Multi-pack	59.1 cm long 34.3 cm wide 29.2 cm high (23.25 13.5 11.5 inches)	3 drives: 5.4 kg (12 lbs) 4 drives: 6.5 kg (15 lbs) 5 drives: 8.2 kg (18 lbs)

Packing the Tape Drive

To pack the tape drive for shipment, follow these steps:

1. Obtain the original shipping carton or contact your vendor to receive a new one.
2. Assemble the carton and tape it shut at the bottom with two-inch (51 mm) packing tape.
3. Place each tape drive in an antistatic bag. Tape the bag shut.
4. Place the bottom packing cushion in the carton, with the fitted area for the drive or drives facing up.
5. **If you are shipping a single drive**, pack the drive in the single-pack shipping carton as shown in Figure 12.

If you are shipping three or more drives, refer to Figure 13 and place three, four, or five drives in the bottom packing cushion of the multi-pack carton as follows:

Three drives: use slots 1, 3, and 5.

Four drives: use slots 1, 2, 4, and 5.

Place the top packing cushion over the drives.

6. Close the carton and tape the top seam so that the carton is completely closed.

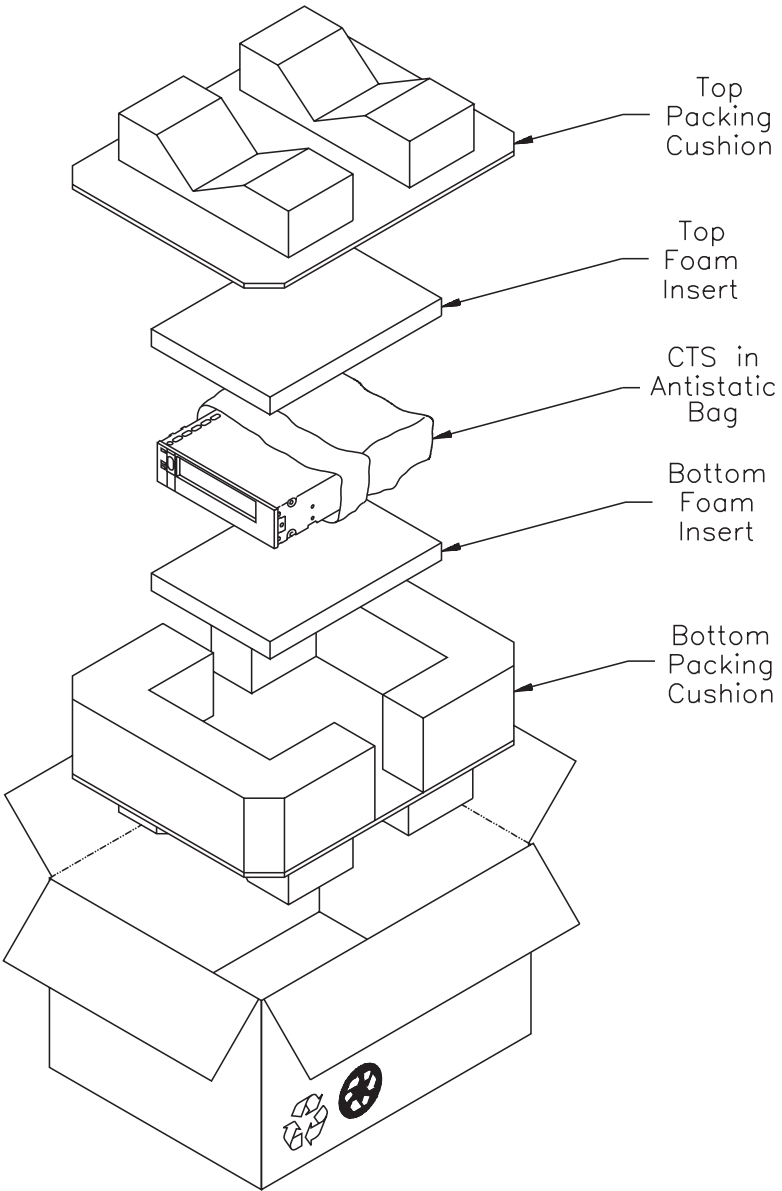

Figure 12 Single-pack carton and packing materials

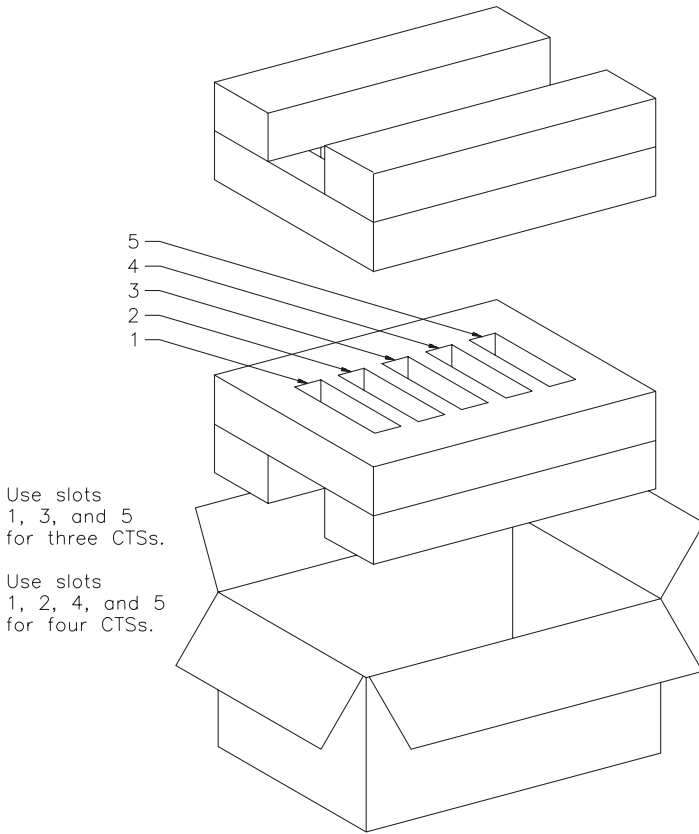

Figure 13 Multi-pack carton and packing materials

Environmental Requirements for Shipment

When shipping a tape drive, be sure to comply with the environmental specifications shown in Table 5.

Table 5 Environmental specifications for shipping the tape drive

Temp. Range	-40° C to +60° C (-40° F to +140° F)
Temp. Variation	1° C per minute up to a maximum of 20° C per hour (2° F per minute up to a maximum of 36° F per hour)
Rel. Humidity	10% to 90% non-condensing
Wet Bulb	26° C max (79° F max)
Altitude	-304.8 m to +12,192 m (-1,000 ft to +40,000 ft)

Appendix A Installation Requirements

This appendix lists the requirements for the following items:
SCSI cable

- SCSI connector
- Power cable
- Power connector

It also provides guidelines for attaching the tape drive to a frame and adding optional chassis grounding.

SCSI Cable

The SCSI cable for connecting the tape drive to the host is not provided with the tape drive. You must provide a cable that complies with the appropriate safety and regulatory agency requirements. To comply with FCC, Canadian DOC, and VDE limits, the tape drive requires shielded cables when the cables are external to the mounting enclosure.

General Requirements

Use a 50-conductor flat cable or 25-signal twisted pair cable. A minimum conductor size of 28 AWG is recommended to minimize noise effects and ensure proper distribution of terminator power.

Ideally, to match the cable terminators, the cable should have a characteristic impedance of 122 ohms (differential) or 132 ohms (single-ended). However, since cables with this high of a characteristic impedance are not generally available, somewhat lower impedances are acceptable. A characteristic impedance of 100 ohms \pm 10% is recommended for unshielded flat or twisted-pair ribbon cable. A characteristic impedance greater than 90 ohms is recommended for shielded cables.

Note: To minimize discontinuities and signal reflections, ensure that cables used on the same bus have the same impedances.

Cable Length Requirements for Differential Configurations

For differential SCSI configurations, ensure that the sum of all the SCSI cable lengths does not exceed 25.0 meters (82.02 feet). A stub length of no more than 0.2 meters (8 inches) is allowed off the mainline interconnection within any connected equipment. The stub length within the tape drive is less than 50 mm (1.97 inches).

Cable Length Requirements for Single-Ended Configurations

For single-ended SCSI configurations, ensure that the sum of all the SCSI cable lengths does not exceed 6.0 meters (19.68 feet). A stub length of no more than 0.1 meters (4 inches) is allowed off the mainline interconnection within any connected equipment. The stub length within the tape drive is less than 50 mm (1.97 inches).

SCSI Connector

To connect the tape drive to the SCSI bus, use a 50-pin female ribbon cable connector (AMP™ No. 1-746285-0 or equivalent). The tape drive's SCSI connector is located at the rear of the tape drive. The connector is a 50-pin male ribbon cable connector, consisting of two rows of 25 pins with adjacent pins 2.54 mm (0.1 inch) apart. For information about the specific SCSI connector pin assignments for differential and single-ended tape drives, refer to the *EXB-8205 and EXB-8505 Product Specification*.

Power Supply

The tape drive operates from standard +5 VDC and +12 VDC supply voltages; it does not use external AC power. Safety agency certification requires that the supplied voltage be from a Safety Extra-Low Voltage source (per IEC 950).

CAUTION

The tape drive does not provide any overvoltage or overcurrent protection. For this reason, be sure that the power is off before connecting the tape drive to power.

Table 6 lists the power specifications for the single-ended and differential configurations of the tape drive.

Table 6 Power specifications for the tape drive

	+5 Volts	+12 Volts
Tolerance	±5%	
Ripple and noise	125 mVpp max	
Nominal operating current	1.7 Amps (single-ended) 2.1 Amps (differential)	0.5 Amps (single-ended) 0.5 Amps (differential)
Maximum current	2.8 Amps (single-ended) 3.2 Amps (differential)	1.6 Amps (single-ended) 1.6 Amps (differential)
Operating power consumption	14.5 watts (single-ended) 16.5 watts (differential)	
Idle power consumption	13.0 watts (single-ended) 14.5 watts (differential)	

Power Connector

The power connector used in the tape drive is compatible with power connectors used for standard 5.25-inch devices. To connect the tape drive to a power cable, use an AMP 1-480424-0 series or equivalent female connector. For information about the specific power connector pin assignments, refer to the *EXB-8205 and EXB-8505 Product Specification*.

Attaching the tape drive to a Frame

The main housing of the tape drive includes three sets of mounting holes (two sets on the sides and one set on the bottom, as shown in Figures 14 and 15) to allow for a number of mounting positions. These mounting holes accommodate M3 5 6 mm screws. Refer to the *EXB-8205 and EXB-8505 Product Specification* for detailed information about the spacing of these mounting holes.

When mounting the tape drive, follow these guidelines:

- The mounting location must meet the environmental requirements discussed in the Product Specification for the tape drive. These requirements specify limits for operating temperature, humidity, airflow, particulate contamination, shock, and vibration.
- The tape drive must be mounted solidly and securely. To assure reliability, there must be no distortion of the tape drive's metal housing. Do not install the tape drive in such a way that its frame is unsupported. For example, do not hang the tape drive by an edge.
- You must use at least four mounting holes to secure the tape drive. It is highly recommended that you use the four holes from only one set ("A," "B," or "C," as shown in Figures 14 and 15). Combinations of mounting holes from different sets may lead to distortion of the frame.
- Objects such as screw heads, cables, or adjacent devices must not press against the frame of the tape drive.
- The ventilation slots at the sides and top of the tape drive must be free of obstruction so that adequate airflow is provided.
- There must be sufficient space to access and operate the front panel controls.

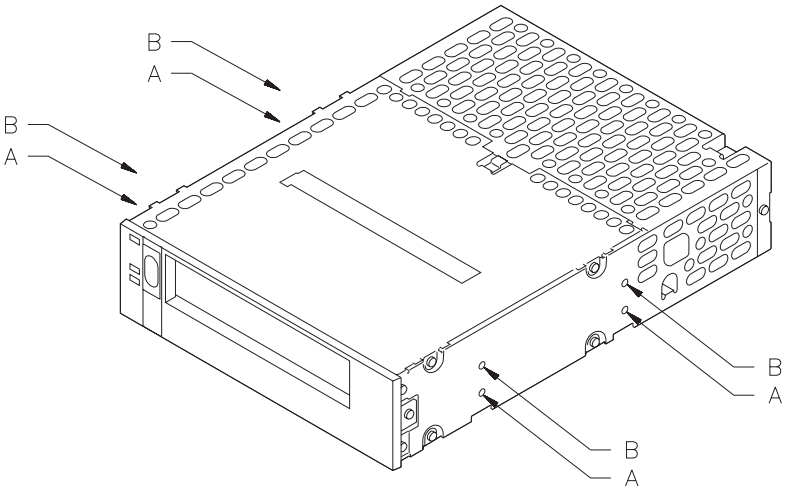

Figure 14 Mounting holes on the sides of the tape drive

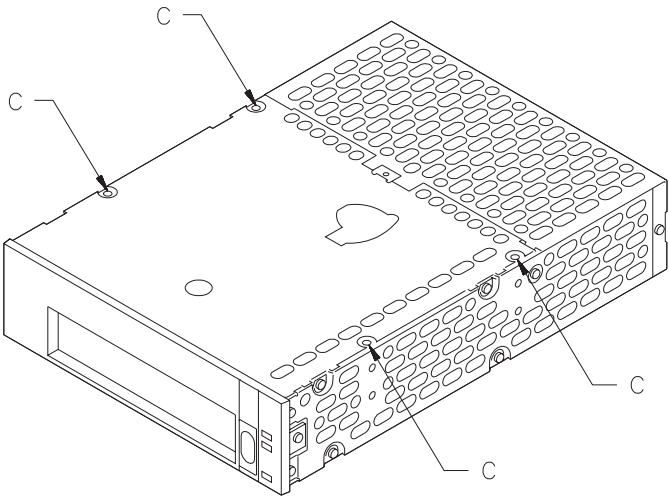

Figure 15 Mounting holes on the bottom of the tape drive

Chassis Grounding (Optional)

If you needed additional chassis grounding, connect a 1/4-inch female spade connector to the ground tab at the rear of the tape drive. Or, connect an M3-0.5 6 mm self-tapping screw to the grounding hole. The ground tab and grounding hole are shown in Figure 7 on page 16.

Note: The power supply returns are connected to the chassis, so you cannot isolate logic common ground from chassis ground.

Appendix B Unload Button Options

Depending on how your tape drive has been configured, the unload button functions in one of three ways:

- As a “normal” unload button (default)
- As a “fast” unload button
- As a “super fast” unload button

Table 7 summarizes the actions that occur with the three unload button options. For further details about these three options, refer to the *EXB-8205 and EXB-8505 8mm SCSI Reference*.

Table 7 Summary of unload button options

tape drive action	Unload button option		
	Normal	Fast	Super Fast
Completes current operation	✓		
Writes buffered data to tape	✓		
Rewinds the tape to PBOT	✓	✓	
Unloads tape from tape path	✓	✓	✓
Ejects the cartridge	✓	✓	✓
Resets			✓

CAUTION

When you use the “fast” or “super fast” unload button while the tape drive is reading or writing data, some data may be lost.

When you use the “super fast” unload button, the tape is unloaded from the tape drive at its current position without being rewound. If the unload occurs when the tape is positioned over data, tape damage and data loss can occur. Exabyte assumes no liability for data loss occurring when the “super fast” unload button option is used.

Note: With the “super fast” unload button, the tape drive will unload the tape even if an error is present during the unload procedure, unless the error is a serious hardware error as follows:

- The tape drive is unable to remove the tape from the tape path and spool all of it into the cartridge. In this case, the tape drive does not eject the cartridge. This prevents the cartridge lid from closing on the exposed tape.
- The front load motor is not functioning. In this case, the tape drive is physically incapable of ejecting the cartridge.

Appendix C Tape Drive Specifications

General	
Interface	SCSI-1 and SCSI-2, single-ended or differential
Mean time between failure	160,000 hours
Physical Characteristics	
Form factor	5.25-inch half-high
Size	4.1 cm high 14.6 cm wide 20.3 cm deep (1.62 5.75 8.00 inches)
Weight	1.2 kilograms (2.6 pounds)
Environmental	
Operating temperature	+5°C to +40°C (+41°F to +104°F)
Operating Rel. humidity	20% to 80%, non-condensing
Maximum Sustained Data Transfer Rate	
8200 format	262 KB/sec
8200c format^a	500 KB/sec
8500 format (EXB-8505)	500 KB/sec
8500c^a format (EXB-8505)	1.0 MB/sec
Capacity on EXATAPE 112m Data Cartridge	
8200 format	Up to 2.5 GB
8200ca format	Up to 5.0 GB
8500 format (EXB-8505 and EXB-8505XL)	Up to 5.0 GB
8500c^a format (EXB-8505 and EXB-8505XL)	Up to 10.0 GB
Capacity on EXATAPE 160m XL Data Cartridge (XL Tape Drives Only)	
8200 format	Up to 3.5 GB
8200ca format	Up to 7.0 GB
8500 format (EXB-8505XL)	Up to 7.0 GB
8500c format (EXB-8505XL)^a	Up to 14.0 GB
Power	
Supply voltages	Standard +5 VDC and +12 VDC ±5%
Maximum current	2.8 Amps (single), 3.2 Amps (differ) at +5 VDC; 1.6 Amps at +12 VDC
Operating power consumption	14.5 watts (single-ended) 16.5 watts (differential)

^a Assuming a 2:1 compression ratio

Index

C

- cable requirements
 - power cable 38
 - SCSI cable 36 – 37
- cartridges
 - see data cartridges
- cartridge tape subsystem
 - see tape drive
- chassis grounding 41
- cleaning the tape drive
 - frequency 28
 - instructions 29 – 30
 - time-to-clean LED 28
- condensation 8
- CTS
 - see tape drive

D

- data cartridges
 - 160 XL 24
 - care of 30 – 31
 - loading 26
 - replacing 31
 - selecting 23
 - storing 30 – 31
 - unloading 27, 42
 - write-protect switch 25
- differential SCSI
 - cable requirements 37
 - power requirements 38
 - termination 7, 12
- drive
 - see tape drive

E

- electrostatic discharge 8
- EXATAPE 8mm Data Cartridge 23 – 24

G

- grounding, chassis 16, 41

H

- handling the tape drive 8

I

- installation
 - attaching to a frame 39 – 40
 - cable requirements 36 – 38
 - connecting to power 16 – 17, 38
 - connecting to SCSI bus 11 – 13
 - in computer drive bay 13 – 17
 - setting the SCSI ID 9 – 10

J

- jumpers for setting SCSI ID 9 – 10

L

- LEDs
 - location 20
 - states indicated by 21 – 22
 - time-to-clean indication 28
- load procedure 26

M

- maintenance 28 – 30
- mounting requirements 39

O

- operating the tape drive 20 – 27, 42

P

- packing the tape drive 32 – 35
- power cable requirements 38
- power specifications 38
- power, connecting to 16 – 17, 38
- preventive maintenance 28 – 30

R

- R-packs 11 – 12
- remote switch for setting SCSI ID 10
- resistor terminators 11 – 12

S

- SCSI bus
 - cable requirements 36 – 37
 - connecting the tape drive to 11 – 13
 - differential SCSI 37
 - single-ended SCSI 37
 - stub length 37
 - termination 7, 11 – 12
- SCSI ID, setting 9 – 10
- shipping the tape drive 32 – 35
- single-ended SCSI
 - cable requirements 37
 - power requirements 38
 - termination 11
- stub length 37

T

- tape drive
 - cleaning 28 – 30
 - controls and indicators 20 – 21
 - installation 7 – 19, 38 – 40
 - loading a data cartridge 26
 - packing and shipping 32 – 35
 - specifications 44
 - unloading a data cartridge 27, 42
 - unpacking 8
 - terminators for SCSI bus 7, 11 – 12

U

- unload button
 - location 20
 - options 27, 42
- unload procedure 27, 42
- unpacking instructions 8

W

- write-protect switch 25

X

- XL (eXtended-Length)
 - 160m data cartridge 24
 - tape drives 5