

April 7, 1998

TEL:805-498-2111 FAX:805-498-3804 WEB:http://www.semtech.com

DESCRIPTION

The EZ1087 5.0A voltage regulator is a monolithic integrated circuit designed for use in applications requiring a well regulated positive output voltage with low input-output differential voltage requirements and where remote sensing of the output voltage is desired to compensate for connector, wiring and pc board trace resistances or other voltage losses. Other outstanding features include full power usage up to 5.0A of load current, internal current limiting, and thermal shutdown. Specifications guarantee 3.30 VDC output from a 4.75 VDC input.

APPLICATIONS

- GTL+ bus supplies

BLOCK DIAGRAM

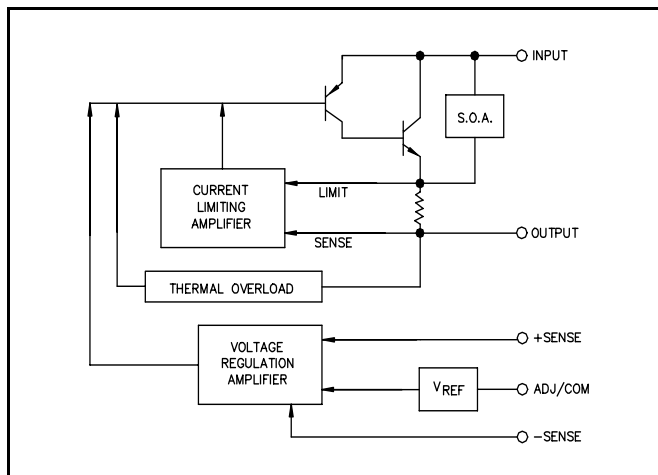

PIN CONFIGURATION

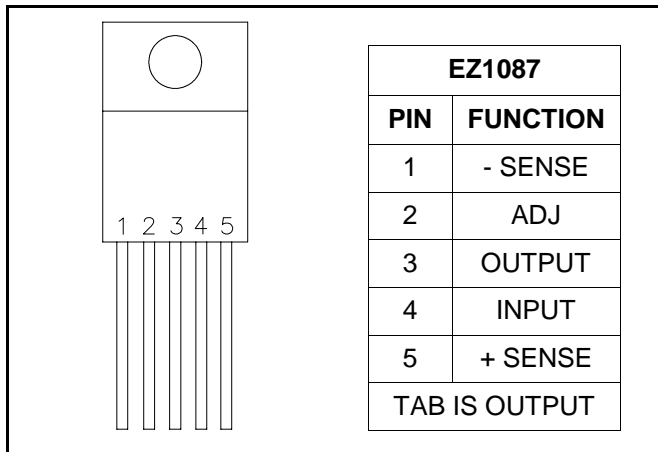

FEATURES

- Low dropout performance, 1.3V max.
- Kelvin remote sense inputs
- Line regulation typically 0.015%
- Load regulation typically 0.1%
- 5-pin TO-220 package

ORDERING INFORMATION

DEVICE	PACKAGE	V _{OUT} VOLTS
EZ1087CT	TO-220	1.30 to 5.7

ABSOLUTE MAXIMUM RATINGS

Parameter	Symbol	Maximum	Units
Input Voltage	V _{IN}	7	V
Sense Pins Differential Voltage	V _{+S} - V _{-S}	4	V
Sense Pin Voltage Range	V _{SP}	Note 1	V
Power Dissipation	P _D	Internally Limited	W
Thermal Resistance Junction to Case	θ _{JC}	2.5	°C/W
Thermal Resistance Junction to Ambient	θ _{JA}	50	°C/W
Operating Junction Temperature Range	T _J	0 to 125	°C
Storage Temperature Range	T _{STG}	-65 to 150	°C
Lead Temperature (Soldering) 10 Sec	T _{LEAD}	260	°C

Note:

$$(1) (V_{OUT} - 1V) \leq V_{\pm SENSE} \leq (V_{OUT} + 0.4V)$$

April 7, 1998

ELECTRICAL CHARACTERISTICS

 Unless otherwise specified, $V_{IN} = 2.75V$ to $7.0V$ and Adj $I_O = 10mA$ to $5.0A$

Parameter	Symbol	Test Conditions			Test Limits			Units
		V_{IN}	I_O	$T_J^{(4)}$	Min	Typ	Max	
Reference Voltage ⁽¹⁾	V_{REF}	5V	10mA	25°C	1.238	1.250	1.262	V
Adj Voltage Version				O.T.	1.225	1.250	1.275	
Line Regulation ⁽¹⁾	$REG_{(LINE)}$		10mA	25°C		0.015	0.2	%
				O.T.		0.035	0.2	
Load Regulation ⁽¹⁾	$REG_{(LOAD)}$	5V		25°C		0.1	0.3	%
				O.T.		0.2	0.4	
Dropout Voltage $\Delta V_{REF} = 1\%$	V_D			25°C		1		V
				O.T.		1.1	1.3	
Current Limit	I_{CL}			O.T.	5.0	7.5		A
Temperature Coefficient	T_C			O.T.		0.005		%/°C
Adjust Pin Current	I_{ADJ}			25°C		55		µA
				O.T.			90	
Adjust Pin Current Change	ΔI_{ADJ}			O.T.		0.2	5	µA
Temperature Stability	T_S	5V	0.5A	O.T.		0.5		%
Minimum Load Current	I_O	5V		O.T.		5	10	mA
RMS Output Noise ⁽²⁾	V_N			25°C		0.003		% V_O
Ripple Rejection Ratio ⁽³⁾	R_A	5V	5.0A	O.T.	60	72		dB
Common Mode ⁽⁵⁾ Range of Sense Pins	V_{CM}			25°C		0.4		mV
Differential Gain of Sense Pins				25°C		11		V / V
Sense Bias Current	I_B			25°C		0.3		µA

NOTES:

- (1) Low duty cycle pulse testing with Kelvin connections required.
- (2) Bandwidth of 10 Hz to 10 kHz.
- (3) 120 Hz input ripple (C_{ADJ} for ADJ = 25µF).
- (4) Over Temp. (O.T.) = over specified operating junction temperature range.
- (5) $(V_{OUT} - 1V) \leq V_{\pm SENSE} \leq V_{OUT}$.

April 7, 1998

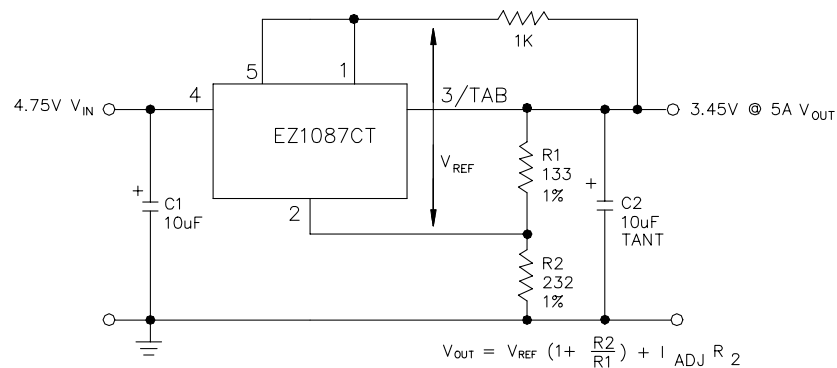
TYPICAL APPLICATIONS
ADJUSTABLE VOLTAGE REGULATOR ⁽¹⁾⁽²⁾

(1) C1 NEEDED IF DEVICE IS FAR FROM FILTER CAPACITORS.

(2) C2 REQUIRED FOR STABILITY.

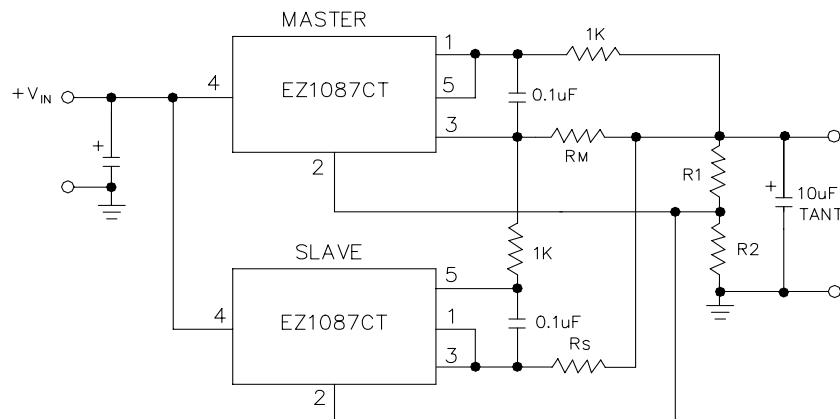
PARALLELING EZ1087 FOR HIGHER CURRENT

For paralleling more than two devices, duplicate slave section.

Minimum load current = (10mA) (# of devices in parallel).

 R₁, R₂ network can be used as a minimum load.

 R_M = 8m ohm 10" of #20 A.W.G. solid wire (copper).

 R_S = 7.3m ohm. 9.1" of #20 A.W.G. solid wire (copper).

 R_M and R_S should be non-inductive. This is easily accomplished by folding the wire back upon itself so that the fields generated by current flowing in the wire cancel.

April 7, 1998

DEVICE OUTLINE - 5 PIN TO-220
