



ExplorIR[®]-M CO2 Sensor

📈 Measurement range: 0-5%; 0-20%; 0-100%

🔋 Battery applications ⚡ Low power

🔗 Robust 📏 Miniature



Overview

ExplorIR®-M is a robust, low power, CO2 sensor in miniature format. Its compact design enables easy integration into gas monitoring and detection systems.

The sensor is built to reliably measure CO2 levels in harsh environments, up to 100% concentration. This includes applications exposed to varying degrees of pressure, and high vibration conditions.

Its low power requirement also makes it ideal for battery powered systems, including portable, wearable and self-powered applications.

ExplorIR®-M is built on our unique patented LED technology platform and optical designs. It's this solid-state technology that enables best-in-class power consumption, lifetime and durability.

Applications

ExplorIR®-M is available in measurement ranges from 0-5%, 0-20%, and 0-100% concentration. The sensor is suitable for a range of process control, and similar demanding applications.

It can be used for battery applications, where low power consumption is required. This includes IoT applications, such as wearables.

Examples of markets where ExplorIR CO2 sensors are being successfully used:

- Agriculture
- Diving
- Aerospace
- Incubators
- Refrigeratio
- Healthcare
- Safety
- Food packaging
- Food storage/ transportation

Benefits

- Reliable in harsh, volatile environments
- Fits neatly inside compact instruments
- Ideal for low power and battery applications
- Up to 50X lower power than typical NDIR CO2 sensors
- Low maintenance
- Suitable for wireless, portable, wearable and self-powered systems
- Integrates with wireless IoT networks such as ZigBee, Wifi, LoRa, Bluetooth, SigFox and EnOcean

Features

- Low power/energy consumption - 3.5mW
- Measures up to 100% CO2 concentration
- >15 years lifetime
- Miniature format
- Solid-state - no moving parts, no heated filaments
- Vibration and shock resistant
- Non-heating
- Digital (UART) output
- RoHS compliant
- Manufactured in the UK



General performance

Start-up time¹	1.2 secs
Operating conditions- Temperature	0°C to 50°C (standard) -25°C to 55°C (extended range)
Operating conditions- Humidity²	0 to 95% RH, non-condensing
Recommended storage	-30°C to +70°C

CO2 measurement

Sensing method	Solid-state Non-Dispersive InfraRed (NDIR) absorption Patented solid-state LED and detector Patented gold-plated optics
Sample method	Diffusion
Measurement range	0-5% 0-20% 0-100%
Accuracy³	± (70ppm+5% of reading) (100% range ± (300ppm+5% of reading))
Pressure dependence⁴	0.15% of reading per mbar in normal atmospheric conditions
Operating pressure range⁵	500mbar – 10 bar
Response time, T90⁶	10 secs - 2 mins

Electrical

Power input⁷	3.25 to 5.5V. (3.3V recommended) Peak Current 33mA Average Current <1.5mA
Power consumption⁷	3.5mW
Connector	4 x 0.5mm sq pins (see drawings)
Communication	UART (standard)

Warranty

Sensor warranty⁸	1 year
------------------------------------	--------

1 Time to a valid reading is determined by digital filter setting. Typically 4-8 seconds.

2 For extended operation in high temperature and humidity environments, contact GSS

3 All measurements are at NTP unless stated otherwise.

4 Calibrated for 1013mbar. GSS can supply advanced pressure correction advice when operating outside normal atmospheric conditions.

5 External pressure calibration required.

6 Response time to a step change in gas level is dependent on application/filter/flow rate/diffusion.

7 Power measurements for standard CO2 sensor with 2 readings per second. Temperature and RH% measurements increase power consumption.

8 Gas Sensing Solutions Ltd (GSS Ltd) offers a limited one (1) year manufacturer's warranty on its products commencing from the date of original purchase. The warranty is limited to defects in materials and workmanship and does not cover damage or abnormal wear and tear resulting from abuse, misuse, or accidental damage. The warranty excludes operational damage due to exposure to blasts or other threats such as excessive abrasion or flames. Unauthorized repairs or alterations void the product warranty. GSS Ltd cannot and does not assume liability for defective products not manufactured or supplied by it even though such be used in conjunction with products manufactured by GSS Ltd.

CONNECTION	DESCRIPTION	COMMENTS
0V	GND CONNECTION	0V
V+	POSITIVE POWER SUPPLY	3V3 TO 5V
Tx-OUT	UART Tx FROM SENSOR	V _{oh} WILL BE 3V. SENSOR OUTPUT.
Rx-IN	UART Rx TO SENSOR	USED FOR CONFIGURATION

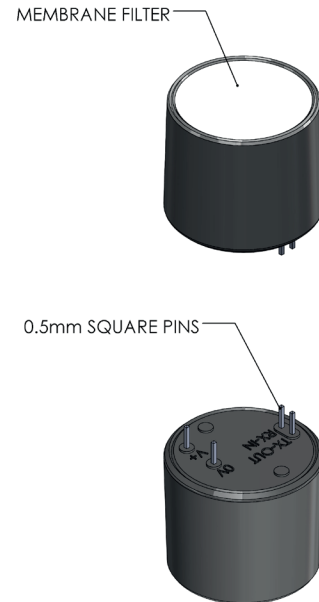
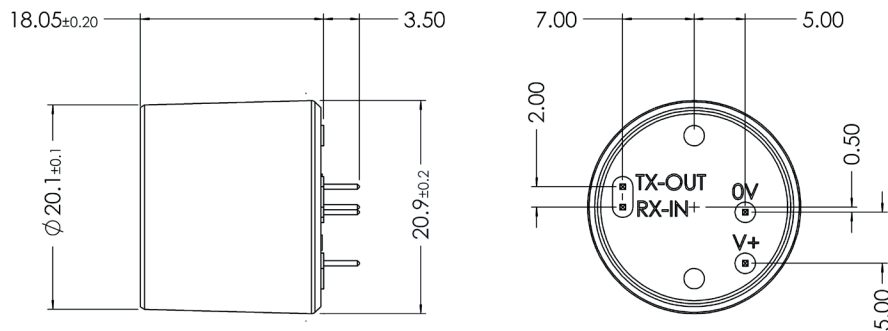

THIS INFORMATION SUPPLIED BY GSS IS BELIEVED TO BE ACCURATE AND RELIABLE. HOWEVER NO RESPONSIBILITY IS ASSUMED BY GSS LTD FOR ITS USE.

Put it to the test

Our evaluation kit contains everything you need to test the sensor for your project requirements. The USB cable allows you to easily connect the ExplorIR®-M sensor to your PC, for real-time CO2 readings.

- CO2 sensor (including adapter if specified)
- USB connecting cable
- Evaluation guide on USB stick

Please visit our website to [request a quote](#) for an evaluation kit.

Technical support

The GSS team are specialists in CO2 sensor design, manufacture and customisation. We can advise how best to integrate our award-winning sensors into your product or process. Whether it's a fixed unit, portable instrument, wearable device, or energy harvester, our engineering team have the experience to help bring your project to life.

For more information about GSS and our technology, please visit our [About](#) page.

Custom sensors

If you need the sensor to be altered to your specific requirements, our engineering team can develop a custom solution for you. Please [contact us](#) to discuss your project requirements with our engineering department.

This documentation is provided on an as-is basis and no warranty as to its suitability or accuracy for any particular purpose is either made or implied. Gas Sensing Solutions Ltd will not accept any claim for damages howsoever arising as a result of use or failure of this information. Your statutory rights are not affected. This information is not intended for use in any medical appliance, device or system in which the failure of the product might reasonably be expected to result in personal injury. As GSS is committed to continuous improvement, this document provides information that may be subject to change without notice.

Document version no: **18/10/18-002**