



FN-LINK TECHNOLOGY LIMITED  
 5th Floor, A Building, Haoye Logistics Park,  
 Shugang Channel, Bao'an District,  
 Shenzhen City, CHINA  
 TEL: 86-0755-29558186  
 FAX: 86-0755-29558196  
 Website: [www.fn-link.com](http://www.fn-link.com)

### Product Specification

IEEE 802.11 b/g/n 2.4GHz 1T1R WiFi with Bluetooth v2.1+EDR/Bluetooth 3.0/3.0+HS/4.0

Project Name	Realtek RTL8723BU USB Wi-Fi+BT Combo Module
Model NO	<u>F23BUUM13-W2</u>
Customer	
Customer's Part NO	

Approved: Sunny LIU	Check: JIM HU	Draft: SJ LI
---------------------	---------------	--------------

Feedback of customer's Confirmation

We accept the specification after Confirmed.

Customer	Customer signature	Approved Date

**CONTENTS**

0 REVISION HISTORY..... 3

    0.1 MODEL NO DEFINITION..... 3

1 INTRODUCTIONS..... 4

    1.1 OVERVIEW..... 4

    1.2 PRODUCT FEATURES..... 4

2 GENERAL SPECIFICATION..... 5

    2.1 WIFI RF SPECIFICATION..... 5

    2.2 POWER CONSUMPTION..... 6

3 MECHANICAL SPECIFICATION..... 6

    3.1 OUTLINE DRAWING..... 6

    3.2 RECOMMENDED FOOTPRINT..... 6

    3.3 PIN DEFINITION..... 7

4 ENVIRONMENTAL REQUIREMENTS..... 8

    4.1 CONDITIONS..... 8

    4.2 RECOMMENDED REFLOW PROFILE..... 8

    4.3 NOTICE..... 8

5 PACKING INFORMATION..... 9

0. Revision History

REV NO	Date	Modifications	Draft	Approved
Rev0.1	2014-2-8	First Released	XJ Hu	Symen Song
Rev0.2	2014-6-24	Packing information	SJ LI	Symen Song
Rev0.3	2014-8-13	Modified the function of PIN13 and PIN14.	SJ LI	Symen Song

0.1. Model No Definition

Example: F23BUUM13-W2

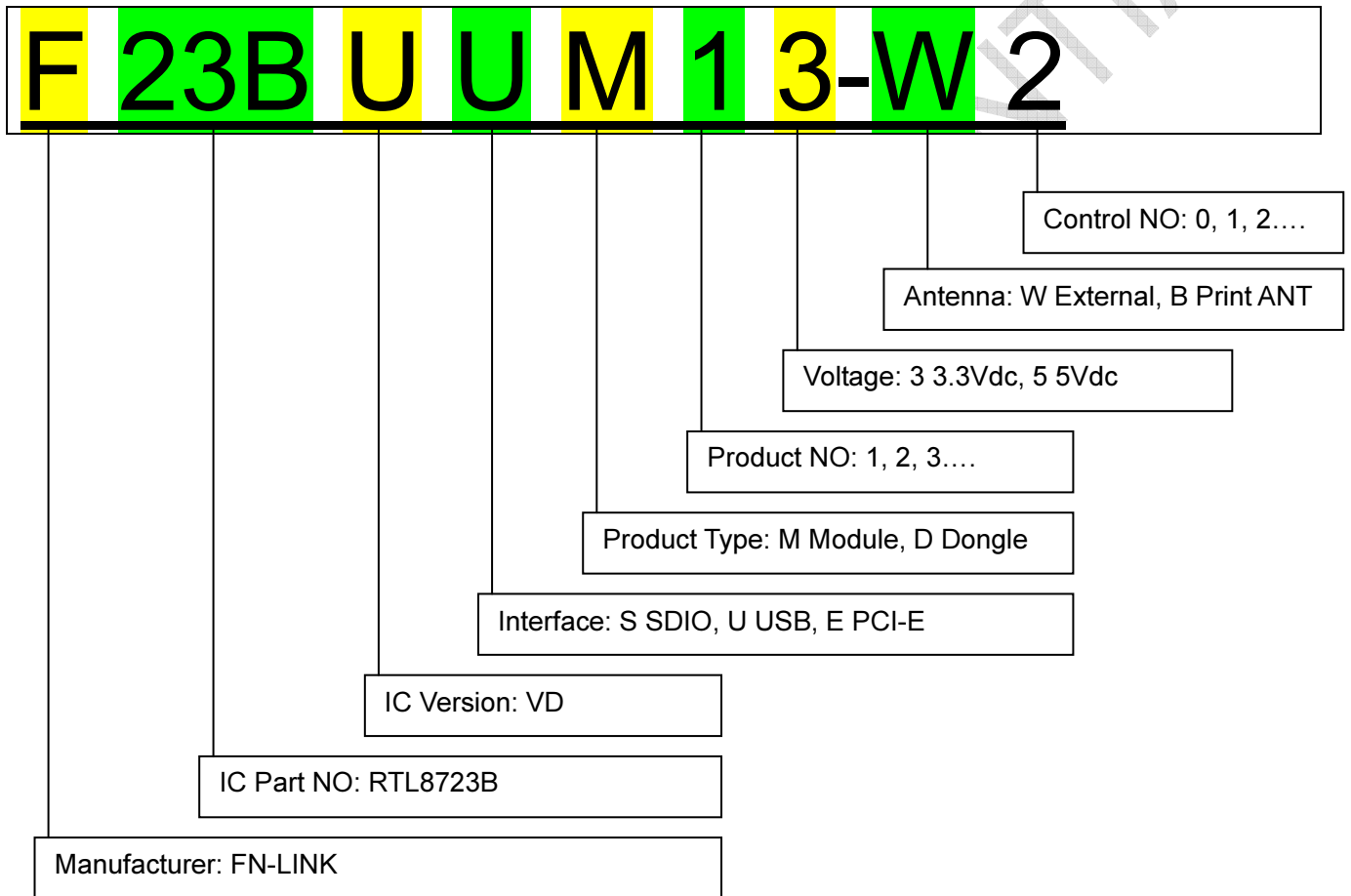

1. Introduction

1.1 Over view

F23BUUM13-W2 is a small size and low profile of WiFi + BT Combo module with LGA (Land-Grid Array) footprint, board size is 13.2mm\*12.0mm with module thickness of 2mm. It can be easily manufactured on SMT process and highly suitable for tablet PC, ultra book, mobile device and consumer products. It provides USB interface for WiFi to connect with host processor and high speed USB interface for BT. It also has a PCM interface for audio data transmission with direct link to external audio codec via BT controller. The WiFi throughput can go up to 150Mbps in theory by using 1x1 802.11n b/g/n MIMO technology and Bluetooth can support BT2.1+EDR/BT3.0 and BT4.0.

F23BUUM13-W2 uses Realtek RTL8723BU, a highly integrated WiFi/BT single chip based on advanced COMS process. RTL8723BU integrates whole WiFi/BT function blocks into a chip, such as USB, MAC, BB, AFE, RFE, PA, EEPROM and LDO/SWR, except fewer passive components remained on PCB. The general block diagram for the module is shown in Figure 1

*Controller with Antenna Diversity*

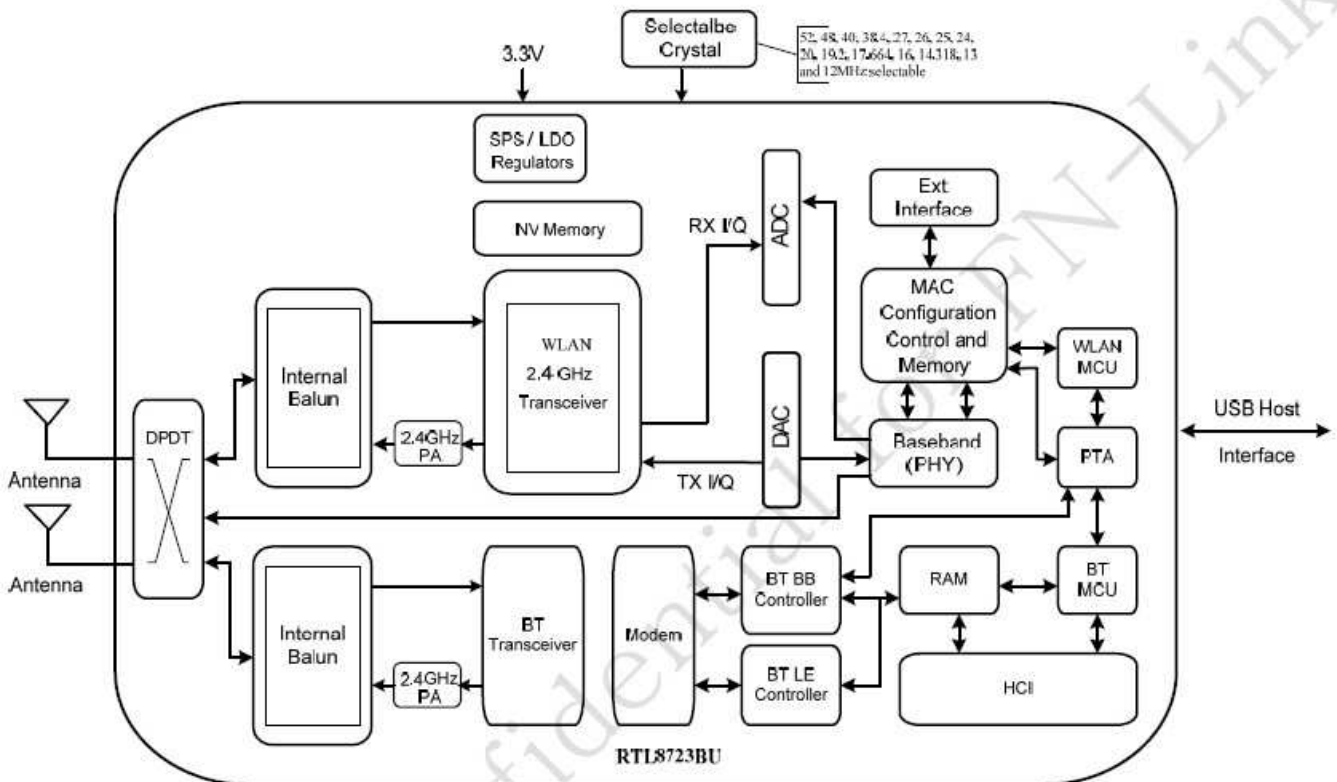

Figure 1. Single-Band 11n (1x1) and Integrated Bluetooth Controller Solution with Antenna Diversity

Figure 1

1.2 Product Features

- Operate at ISM frequency bands (2.4GHz)
- USB for WiFi and Bluetooth
- IEEE standards support: IEEE 802.11b, IEEE 802.11g, IEEE 802.11n, IEEE 802.11d, IEEE 802.11e, IEEE 802.11h, IEEE 802.11i
- Fully Qualified for Bluetooth 2.1+EDR specification including both 2Mbps and 3Mbps modulation mode
- Fully qualified for Bluetooth 3.0
- Fully qualified for Bluetooth 4.0 Dual mode
- Full-speed Bluetooth operation with Piconet and Scatternet support
- Enterprise level security which can apply WPA/WPA2 certification for WiFi.
- WiFi 1 transmitter and 1 receiver allow data rates supporting up to 150 Mbps downstream and 150 Mbps upstream PHY rates

## 2. GENERAL SPECIFICATION

### 2.1 WiFi RF Specifications

<b>Main Chipset</b>	Realtek RTL8723BU
<b>Operating Frequency</b>	2.400~2.4835GHz
<b>Standards</b>	<b>WiFi:</b> IEEE 802.11b, IEEE 802.11g, IEEE 802.11n, IEEE 802.11d, IEEE 802.11e, IEEE 802.11h, IEEE 802.11i  <b>BT:</b> V2.1+EDR/BT v3.0/BT v3.0+HS/BT v4.0
<b>Modulation</b>	<b>WiFi:</b> 802.11b: CCK(11, 5.5Mbps), QPSK(2Mbps), BPSK(1Mbps), 802.11 g/n: OFDM  <b>BT:</b> 8DPSK, $\pi/4$ DQPSK, GFSK
<b>PHY Data rates</b>	<b>WiFi:</b> 802.11b: 11,5.5,2,1 Mbps 802.11g: 54,48,36,24,18,12,9,6 Mbps 802.11n: up to 150Mbps  <b>BT:</b> 1 Mbps for Basic Rate 2,3 Mbps for Enhanced Data Rate 6,9,12,18,24,36,48,54 Mbps for High Speed
<b>Transmit Output Power (Tolerance: <math>\pm 2.0</math>dBm)</b>	<b>WiFi:</b> 802.11b@11Mbps 16dBm 802.11g@6Mbps 15dBm 802.11g@54Mbps 14dBm  802.11n 13dBm (MCS 0_HT20) 13dBm (MCS 7_HT20) 13dBm (MCS 0_HT40) 13dBm (MCS 7_HT40)  <b>BT:</b> Max +10dBm
<b>Receiver Sensitivity</b>	802.11b@11Mbps $-82 \pm 1$ dBm 802.11g@54Mbps $-71 \pm 1$ dBm 802.11n $-67 \pm 1$ dBm (MCS 7_HT20) $-64 \pm 1$ dBm (MCS 7_HT40)
<b>Operating Channel</b>	<b>WiFi 2.4GHz:</b> 11: (Ch. 1-11) – United States 13: (Ch. 1-13) – Europe 14: (Ch. 1-14) – Japan  <b>BT 2.4GHz:</b> Ch. 0 ~78
<b>Media Access Control</b>	<b>WiFi:</b> CSMA/CA with ACK  <b>BT:</b> AFH, Time Division
<b>Network Architecture</b>	<b>WiFi:</b> Ad-hoc mode (Peer-to-Peer ) Infrastructure mode Software AP WiFi Direct  <b>BT:</b> Pico Net Scatter Net
<b>Security</b>	<b>WiFi:</b> WPA, WPA-PSK, WPA2, WPA2-PSK, WEP 64bit & 128bit, IEEE 802.11x, IEEE 802.11i

	<b>BT:</b> Simple Paring
<b>OS Supported</b>	Android /Linux/Win8.1
<b>Host Interface</b>	<b>WiFi:</b> USB  <b>BT:</b> USB
<b>Operating Voltage</b>	3.3Vdc ±9% I/O supply voltage
<b>Dimension</b>	Typical L13.0*W12.2*T1.6mm

**2.2 Power Consumption**

<b>Power Consumption (Typical by using SWR)</b>	<b>WiFi only:</b> TX Mode: (Continuous mode) 200mA (MCS7/BW40/13dBm) RX Mode: (Conituous mode) 170mA (MCS7/BW40/-60dBm) Associated Idle power saving with DTIM=3 2.1mA Unassociated Idle: 0.1mA RF disable Mode: 0.1mA
	<b>BT:</b> Inquiry & Page Scan: 0.9 mA ACL no traffic: 7.5mA SCO HV3: 15.0mA

**3. Mechanical Specification**

**3.1 Outline Drawing (Unit: ±0.15mm)**

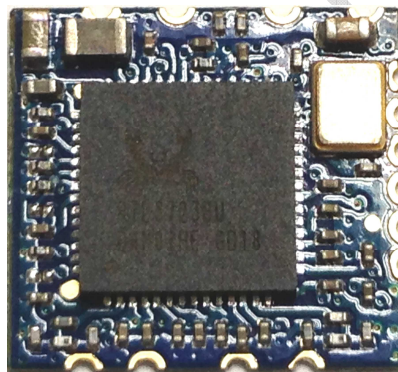

**3.2 Recommended Footprint**

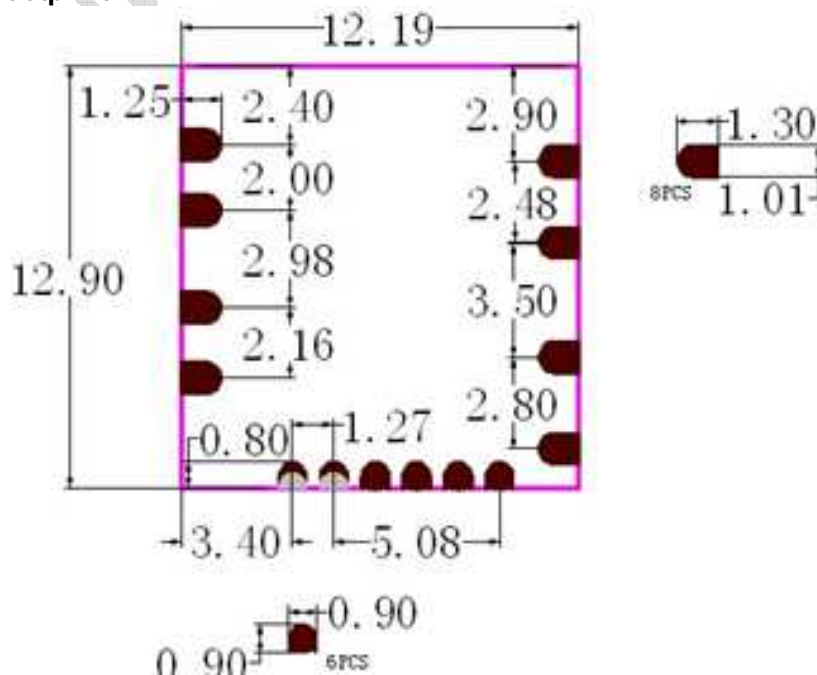

3.3 Pin Definition

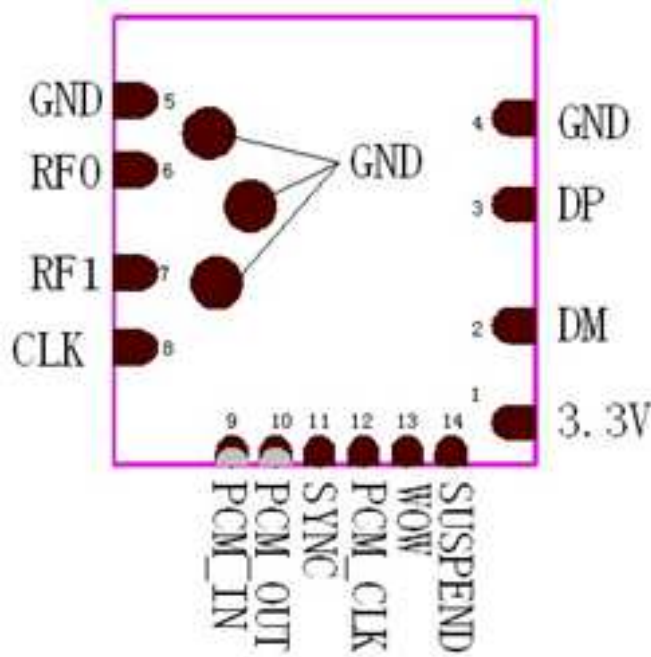

PIN Assignment

Pin #	Name	Description
1	3.3V	Main power voltage source input
2	DM	USB -
3	DP	USB +
4	GND	Ground
5	GND	Ground
6	RF0	RF/BT output
7	RF1	Floating (NC)
8	CLK	Floating (NC)
9	PCM_IN	PCM Control input
10	PCM_OUT	PCM Control output
11	SYNC	SYNC signal
12	PCM_CLK	PCM crystal
13	WOWLAN	Chip wakeup host pin (When not used wake up, it is default idle.)
14	SUSPEND	Host wakeup chip pin (When not used PCM, it is default idle.)
Total	14PINS	13.0*12.2*2.0mm Package

## 4. Environmental Requirements

### 4.1 Conditions

Operating Condition:

Operating Temperature: 0°C to +55 °C  
Relative Humidity: 10-90% (non-condensing)

Storage Condition:

Temperature: -40°C to +80°C (non-operating)  
Relative Humidity: 5-90% (non-condensing)

MTBF: Over 150,000hours

### 4.2 Recommended Reflow Profile

Referred to IPC/JEDEC standard.

Peak Temperature : <250°C

Number of Times : ≤2 times

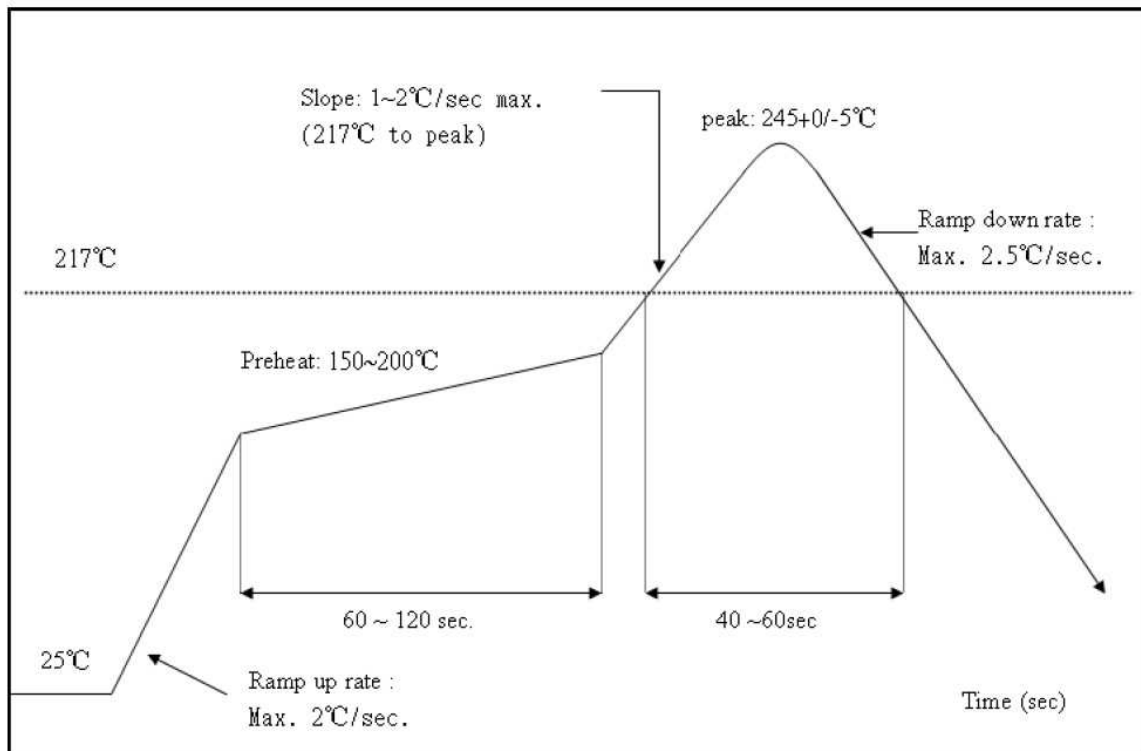

### 4.3 Patch WIFI modules installed before the notice:

WIFI module installed note:

1. Please press 1 : 1 and then expand outward proportion to 0.7 mm, 0.12 mm thickness When open a stencil
2. Take and use the WIFI module, please insure the electrostatic protective measures.
3. Reflow soldering temperature should be according to the customer the main size of the products, such as the temperature set at 250 + 5 °C for the MID motherboard.

About the module packaging, storage and use of matters needing attention are as follows:

1. The module of the reel and storage life of vacuum packing: 1). Shelf life: 8 months, storage environment conditions: temperature in: < 40 °C, relative humidity: < 90% r.h.
2. The module vacuum packing once opened, time limit of the assembly:  
Card: 1) check the humidity display value should be less than 30% (in blue), such as: 30% ~ 40% (pink), or greater than 40% (red) the module have been moisture absorption.  
2.) factory environmental temperature humidity control: ≤ 30°C, ≤ 60% r.h..  
3). Once opened, the workshop the preservation of life for 168 hours.
3. Once opened, such as when not used up within 168 hours:
  - 1). The module must be again to remove the module moisture absorption.
  - 2). The baking temperature: 125 °C, 8 hours.



3.) After baking, put the right amount of desiccant to seal packages.

## **5. Package**

### **5.1 blister packaging**



A piece of 100 PCS

### **5.2 the take-up package**



A roll of 2000pcs

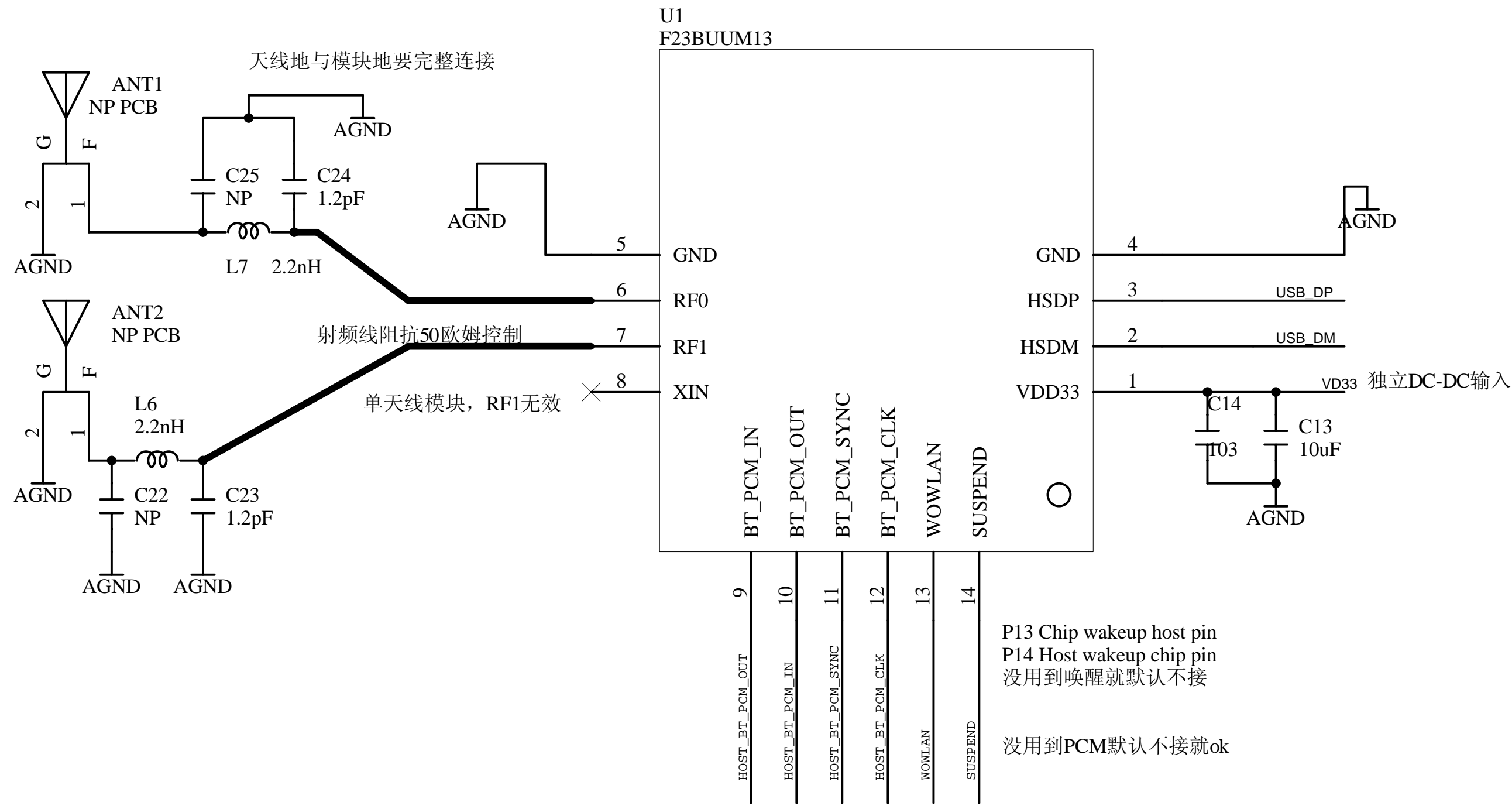

P13 Chip wakeup host pin  
P14 Host wakeup chip pin  
不用到唤醒就默认不接  
不用到PCM默认不接就ok

Title		
Size A4	Number	Revision
Date: 1-Aug-2014	Sheet of	
File: E:\各产品生产资料\ouxunda\realtek\8723b\HDK\BOM23B00\PCB-UM23B02.asc.DDB		