

### High-speed response MCP assembly ideal for high resolution TOF-MS detector Incorporates a two-stage MCP with 4 $\mu$ m channel diameter

The F4655-13 MCP assembly is an ideal detector for high resolution TOF-MS (time-of-flight mass spectroscopy) because of a two-stage MCP with 4 $\mu$ m channel diameter. Our own advanced technology in optimizing MCP design allows obtaining an excellent output waveform with negligible ringing even when detecting very high-speed signals. The dimensions are exactly the same as the F4655-10 MCP assembly, ensuring a compact configuration and easy handling.



TMCPF0088

#### FEATURES

- Excellent time response
- 50 $\Omega$  impedance matching
- Compact and lightweight

#### APPLICATION

- TOF-MS (Time-of-flight mass spectrometer)

#### SPECIFICATIONS

##### GENERAL

Parameter	Value	Unit
Assembly Outer Diameter	38.0	mm
Effective Diameter	14.5	mm
Maximum Height	31.9	mm
MCP Channel Diameter	4	$\mu$ m
Number of MCP Stages	2	-

##### MAXIMUM RATINGS (Absolute values)

MCP Supply Voltage (In-Out)	2	kV
MCP-Out to Anode Voltage	0.5	kV
Electric Potential at Each Terminal	MCP-In: -2.5 MCP-Out: -0.5 Anode: GND	kV
Operating Vacuum Condition	$6.7 \times 10^{-4}$ ( $5 \times 10^{-6}$ )	Pa (Torr)
Baking Temperature	- *	$^{\circ}$ C
Baking Time	- *	h
Baking Vacuum Condition	- *	Pa (Torr)

\* Baking cannot be performed.

##### CHARACTERISTICS (at $1.3 \times 10^{-4}$ Pa ( $1 \times 10^{-6}$ Torr), $T_a = +25^{\circ}$ C)

Gain at 2.0kV	$1 \times 10^6$	-
Plate Resistance per MCP	10 to 100	M $\Omega$
Dark Count at 2.0kV	5	cps/cm <sup>2</sup>

Figure 1: Typical Output Waveform

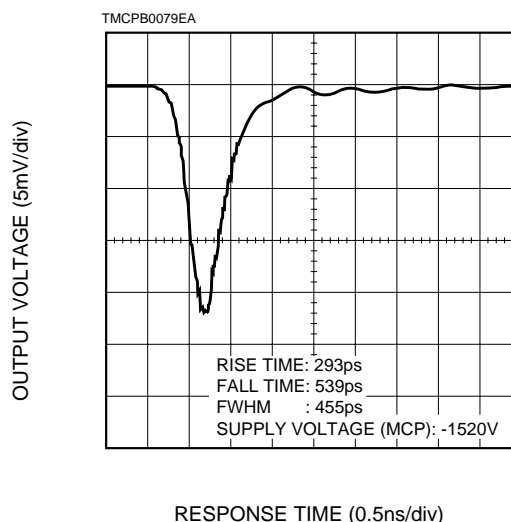

Subject to local technical requirements and regulations, availability of products included in this promotional material may vary. Please consult with our sales office.

Information furnished by HAMAMATSU is believed to be reliable. However, no responsibility is assumed for possible inaccuracies or omissions. Specifications are subject to change without notice. No patent rights are granted to any of the circuits described herein. ©1998 Hamamatsu Photonics K.K.

# MCP ASSEMBLY FOR HIGH RESOLUTION TOF-MS F4655-13

Figure 2: Dimensional Outlines (Unit: mm)

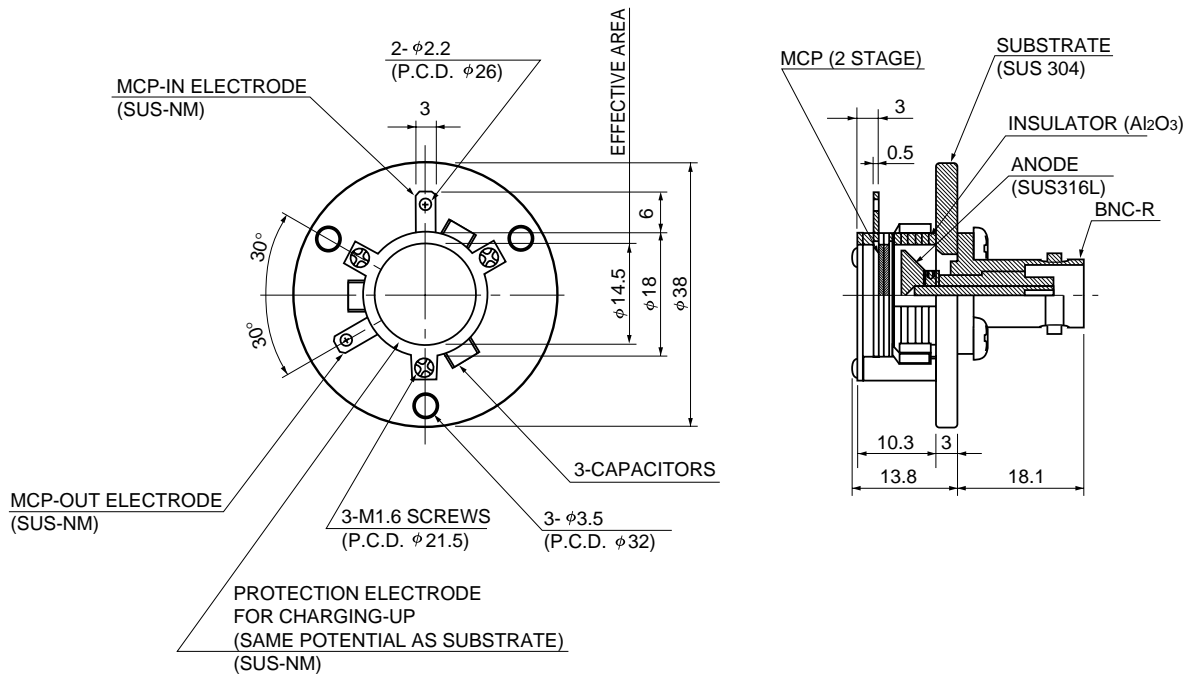

TMCPA0044EA

# HAMAMATSU

HAMAMATSU PHOTONICS K.K., Electron Tube Center

314-5, Shimokanzo, Toyooka-village, Iwata-gun, Shizuoka-ken, 438-0193 Japan, Telephone: (81)539/62-5248, Fax: (81)539/62-2205

U.S.A.: Hamamatsu Corporation: 360 Foothill Road, P.O.Box 6910, Bridgewater, N.J. 08807-0910, U.S.A., Telephone:(1)908-231-0960, Fax:(1)908-231-1218

Germany: Hamamatsu Photonics Deutschland GmbH: Arzbergerstr. 10, D-82211 Herrsching am Ammersee, Germany, Telephone:(49)8152-375-0, Fax:(49)8152-2658

France: Hamamatsu Photonics France: S.A.R.L.: 8, Rue du Saule Trapu, Parc du Moulin de Massy, 91882 Massy Cedex, France, Telephone:(33)1 69 53 71 00, Fax:(33)1 69 53 71 10

United Kingdom: Hamamatsu Photonics UK Limited: Lough Point, 2 Gladbeck Way, Windmill Hill, Enfield, Middlesex EN2 7JA, United Kingdom, Telephone:(44)181-367-3560, Fax:(44)181-367-6384

North Europe: Hamamatsu Photonics Norden AB: F5rsgatan 7, S-164 40 Kista, Sweden, Telephone:(46)8-703-29-50, Fax:(46)8-750-58-95

Italy: Hamamatsu Photonics Italia S.R.L.: Via della Moia, 1/E 20020 Arese, (Milano), Italy, Telephone: (39)2 935 81 733 Fax: (39)2 935 81 741

TMCP1021E01

MAY 1998 SI

Printed in Japan (500)