



F5N50

Power MOSFET

5A, 500V N-CHANNEL POWER MOSFET

DESCRIPTION

The UTC **F5N50** is an N-channel power MOSFET adopting UTC's advanced technology to provide customers with DMOS, planar stripe technology. This technology is designed to meet the requirements of the minimum on-state resistance and perfect switching performance. It also can withstand high energy pulse in the avalanche and communication mode.

The UTC **F5N50** can be used in applications, such as active power factor correction, high efficiency switched mode power supplies, electronic lamp ballasts based on half bridge topology.

FEATURES

- * $R_{DS(ON)} < 1.6\Omega @ V_{GS}=10V, I_D=2.5A$
- * 100% avalanche tested
- * High switching speed

SYMBOL

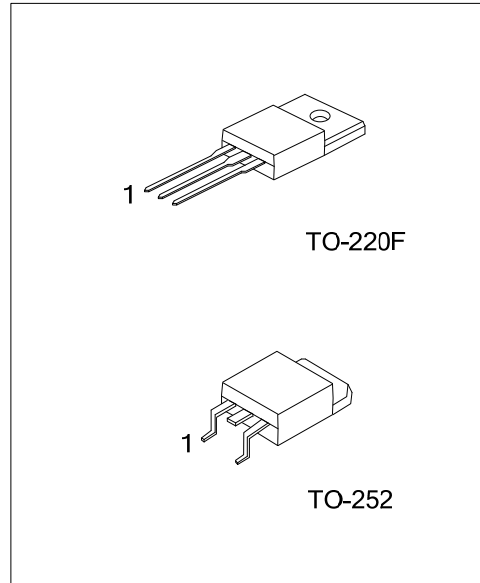
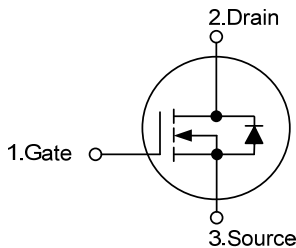

ORDERING INFORMATION

Ordering Number		Package	Pin Assignment			Packing
Lead Free	Halogen Free		1	2	3	
F5N50L-TF3-T	F5N50G-TF3-T	TO-220F	G	D	S	Tube
F5N50L-TN3-R	F5N50G-TN3-R	TO-252	G	D	S	Tape Reel

Note: Pin Assignment: G: Gate D: Drain S: Source

<p>F5N50L-TF3-T</p> <p>(1) Packing Type</p> <p>(2) Package Type</p> <p>(3) Green Package</p>	<p>(1) T: Tube, R: Tape Reel</p> <p>(2) TF3: TO-220F, TN3: TO-252</p> <p>(3) G: Halogen Free and Lead Free</p>
--	--

MARKING

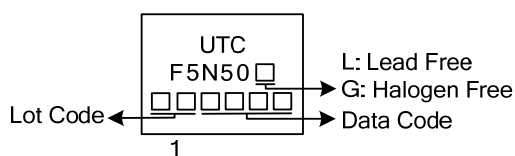

■ ABSOLUTE MAXIMUM RATINGS ($T_c=25^\circ\text{C}$, unless otherwise specified)

PARAMETER		SYMBOL	RATINGS	UNIT
Drain-Source Voltage		V_{DSS}	500	V
Gate-Source Voltage		V_{GSS}	± 30	V
Drain Current	Continuous	I_D	5	A
	Pulsed (Note 2)	I_{DM}	20	A
Avalanche Current (Note 2)		I_{AR}	5	A
Avalanche Energy	Single Pulsed (Note 3)	E_{AS}	200	mJ
	Repetitive (Note 2)	E_{AR}	7.3	mJ
Peak Diode Recovery dv/dt (Note 4)		dv/dt	4.5	V/ns
Power Dissipation	TO-220F	P_D	38	W
	TO-252		54	W
Junction Temperature		T_J	+150	$^\circ\text{C}$
Storage Temperature		T_{STG}	-55~+150	$^\circ\text{C}$

Notes: 1. Absolute maximum ratings are those values beyond which the device could be permanently damaged.

Absolute maximum ratings are stress ratings only and functional device operation is not implied.

2. Repetitive Rating: Pulse width limited by maximum junction temperature

3. $L = 16\text{mH}$, $I_{AS} = 5\text{A}$, $V_{DD} = 50\text{V}$, $R_G = 25\Omega$, Starting $T_J = 25^\circ\text{C}$

4. $I_{SD} \leq 5\text{A}$, $di/dt \leq 200\text{A}/\mu\text{s}$, $V_{DD} \leq BV_{DSS}$, Starting $T_J = 25^\circ\text{C}$

■ THERMAL DATA

PARAMETER		SYMBOL	RATINGS	UNIT
Junction to Ambient	TO-220F	θ_{JA}	62.5	$^\circ\text{C}/\text{W}$
	TO-252		110	$^\circ\text{C}/\text{W}$
Junction to Case	TO-220F	θ_{JC}	3.25	$^\circ\text{C}/\text{W}$
	TO-252		2.13	$^\circ\text{C}/\text{W}$

■ ELECTRICAL CHARACTERISTICS (T_C=25°C, unless otherwise specified)

PARAMETER		SYMBOL	TEST CONDITIONS	MIN	TYP	MAX	UNIT
OFF CHARACTERISTICS							
Drain-Source Breakdown Voltage		BV _{DSS}	I _D =250μA, V _{GS} =0V	500			V
Breakdown Voltage Temperature Coefficient		ΔBV _{DSS} /ΔT _J	Reference to 25°C, I _D =250μA		0.5		V/°C
Drain-Source Leakage Current		I _{DSS}	V _{DS} =500V, V _{GS} =0V			1	μA
			V _{DS} =400V, T _C =125°C			10	
Gate- Source Leakage Current	Forward	I _{GSS}	V _{GS} =30V, V _{DS} =0V			100	nA
	Reverse		V _{GS} =-30V, V _{DS} =0V			-100	nA
ON CHARACTERISTICS							
Gate Threshold Voltage		V _{GS(TH)}	V _{DS} =V _{GS} , I _D =250μA	1.5		3.5	V
Static Drain-Source On-State Resistance		R _{DS(ON)}	V _{GS} =10V, I _D =2.5A		1.25	1.6	Ω
DYNAMIC PARAMETERS							
Input Capacitance		C _{ISS}	V _{GS} =0V, V _{DS} =25V, f=1.0MHz		480	625	pF
Output Capacitance		C _{OSS}			80	105	pF
Reverse Transfer Capacitance		C _{RSS}			15	20	pF
SWITCHING PARAMETERS							
Total Gate Charge		Q _G	V _{GS} =10V, V _{DS} =50V, I _D =1.3A (Note 1, 2)		20	24	nC
Gate to Source Charge		Q _{GS}			4		nC
Gate to Drain Charge		Q _{GD}			5		nC
Turn-ON Delay Time		t _{D(ON)}	V _{DD} =30V, I _D =0.5A, R _G =25Ω (Note 1, 2)		30	50	ns
Rise Time		t _R			50	70	ns
Turn-OFF Delay Time		t _{D(OFF)}			145	100	ns
Fall-Time		t _F			70	105	ns
SOURCE- DRAIN DIODE RATINGS AND CHARACTERISTICS							
Maximum Continuous Drain-Source Diode Forward Current		I _S				5	A
Maximum Pulsed Drain-Source Diode Forward Current		I _{SM}				20	A
Drain-Source Diode Forward Voltage		V _{SD}	I _S =5A, V _{GS} =0V			1.4	V
Reverse Recovery Time		t _{rr}	I _S =5A, V _{GS} =0V,		120		ns
Reverse Recovery Charge		Q _{RR}	dI _F /dt=50A/μs (Note 1)		0.15		μC

Notes: 1. Pulse Test: Pulse width ≤ 300μs, Duty cycle ≤ 2%

2. Essentially independent of operating temperature

TEST CIRCUITS AND WAVEFORMS

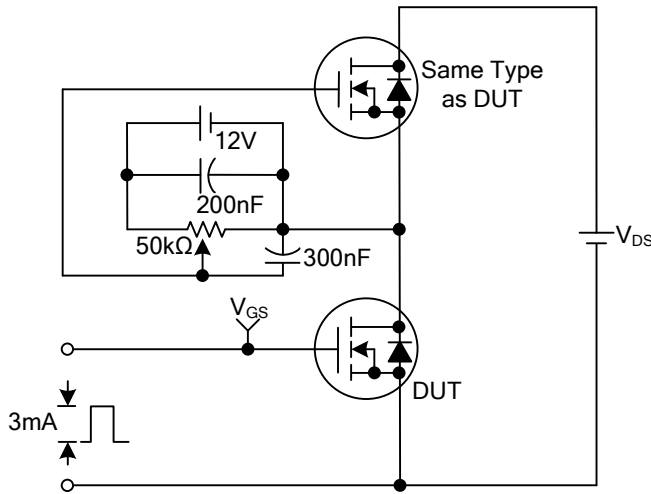

Gate Charge Test Circuit

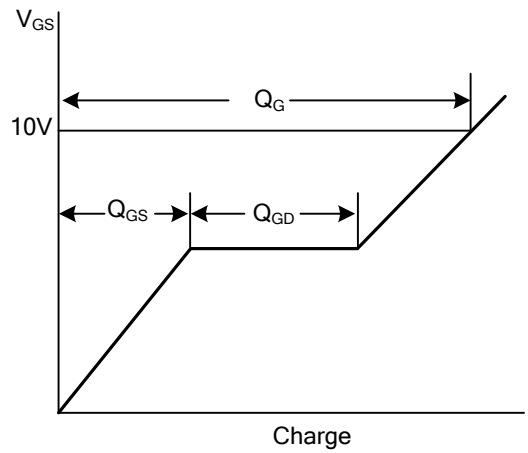

Gate Charge Waveforms

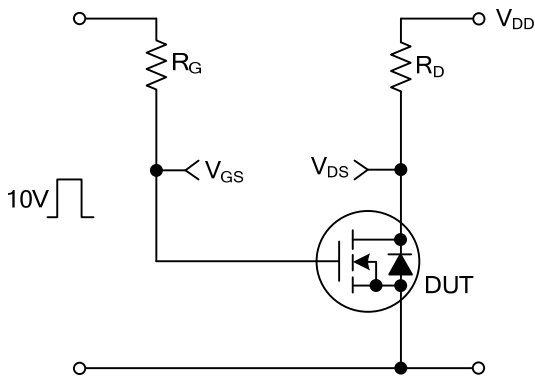

Resistive Switching Test Circuit

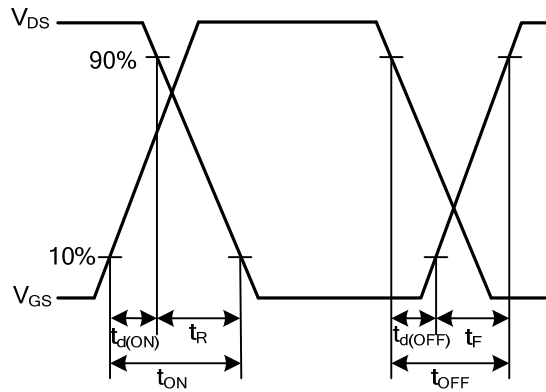

Resistive Switching Waveforms

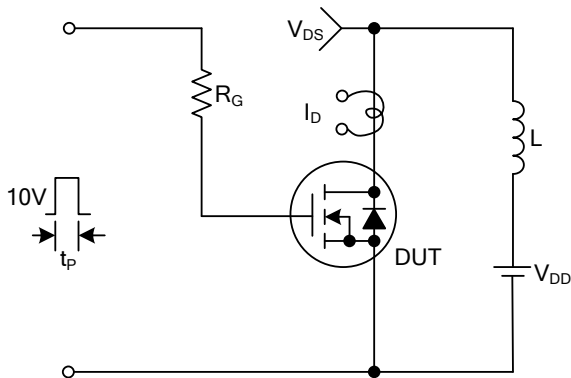

Unclamped Inductive Switching Test Circuit

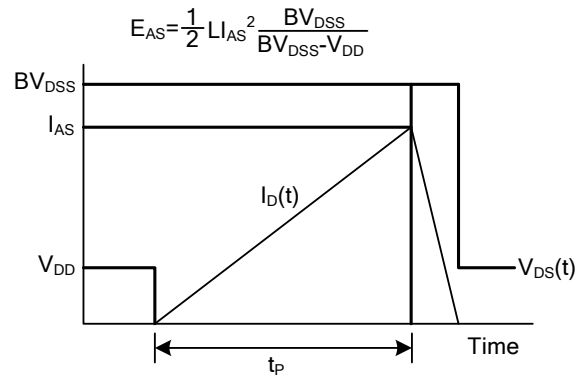

Unclamped Inductive Switching Waveforms

■ TEST CIRCUITS AND WAVEFORMS(Cont.)

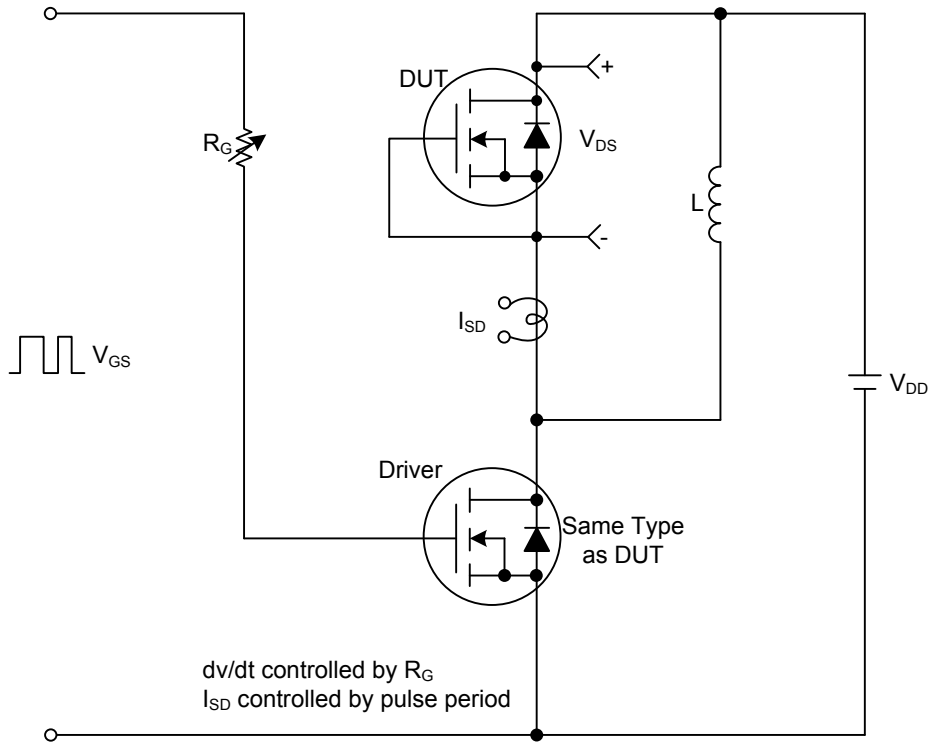

Peak Diode Recovery dv/dt Test Circuit & Waveforms

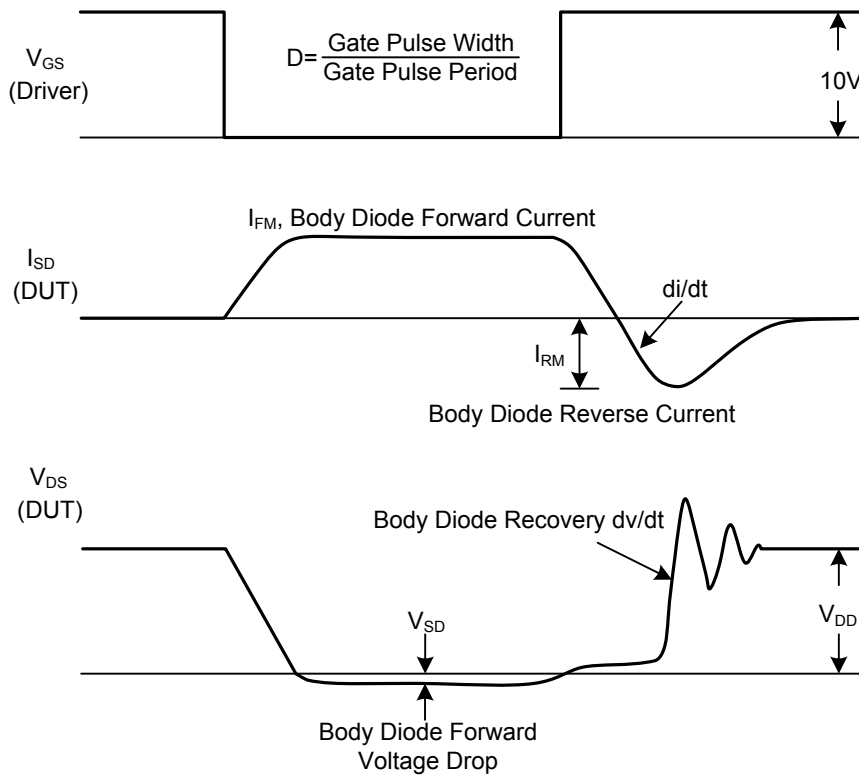

TYPICAL CHARACTERISTICS

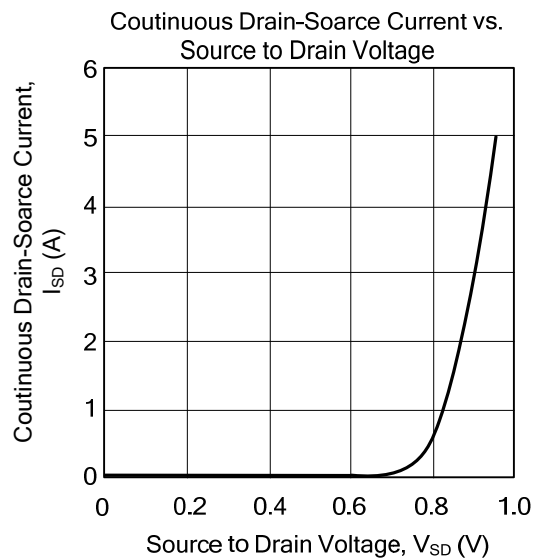
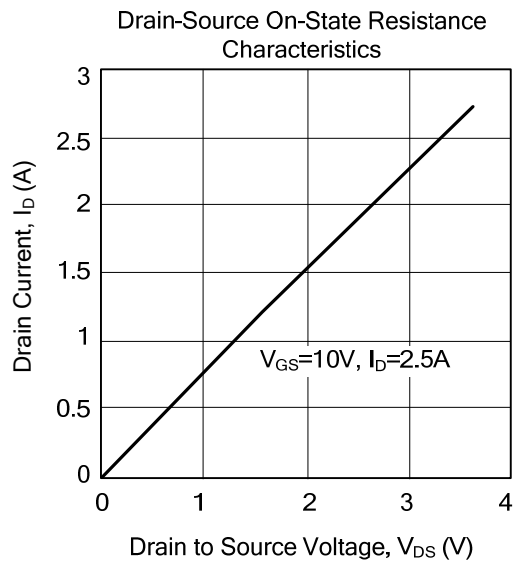
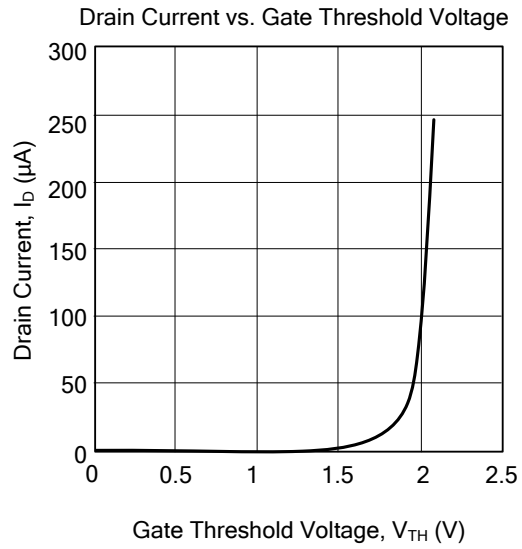
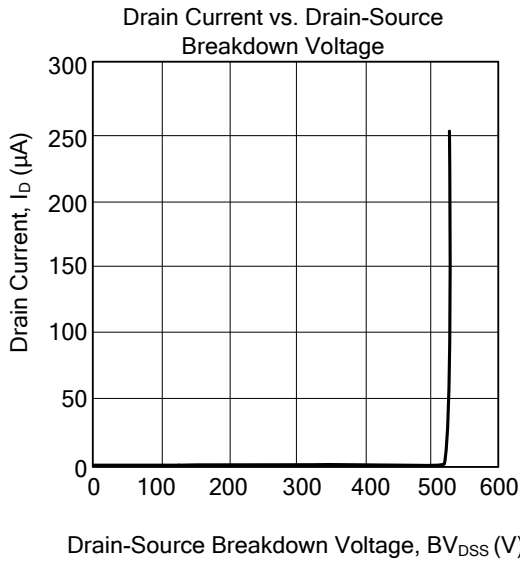

UTC assumes no responsibility for equipment failures that result from using products at values that exceed, even momentarily, rated values (such as maximum ratings, operating condition ranges, or other parameters) listed in products specifications of any and all UTC products described or contained herein. UTC products are not designed for use in life support appliances, devices or systems where malfunction of these products can be reasonably expected to result in personal injury. Reproduction in whole or in part is prohibited without the prior written consent of the copyright owner. The information presented in this document does not form part of any quotation or contract, is believed to be accurate and reliable and may be changed without notice.