

Description

The F6101 is an 8-channel receiver silicon IC designed using a SiGe BiCMOS process for Ku-Band SATCOM phased array applications. The core IC has 6-bit phase control coupled with more than 30dB gain control on each channel to achieve fine beam steering and gain compensation between channels. The device has 15.5dB nominal electric gain and -23dBm IP1dB. The core chip achieves an RMS phase error of 2.5° and RMS gain error of 0.25dB over the frequency of operation. The typical total power consumption is 0.34W (43mW per channel).

Competitive Advantage

- High integration
- Orthogonality of phase and amplitude control
- Advanced Serial Peripheral Interface (SPI) with 4-state memory
- Superior channel-to-channel isolation
- Minimal footprint

Typical Applications

- Ku-Band SATCOM
- Aerospace and Maritime
- Weather Radar
- Beam Steering
- Test and Measurement

Features

- 10GHz to 14GHz operation
- 8 radiation channels
- 6-bit phase control
- 20ns typical gain settling time
- 20ns typical phase settling time
- 2.5° typical RMS phase error
- 0.25dB typical RMS gain error
- 30dB gain attenuation range
- 5-bit IC address
- Integrated proportional-to-absolute temperature (PTAT) sensor with external biasing
- -40°C to +95°C internal temperature sensor
- Programmable 4-state on-chip memory
- Supply voltage: +2.1V to +2.5V
- -40°C to +95°C ambient operating temperature range
- 27°C typical ambient operating temperature
- 5mm x 5mm, 40-QFN package

Block Diagram

Figure 1. Block Diagram

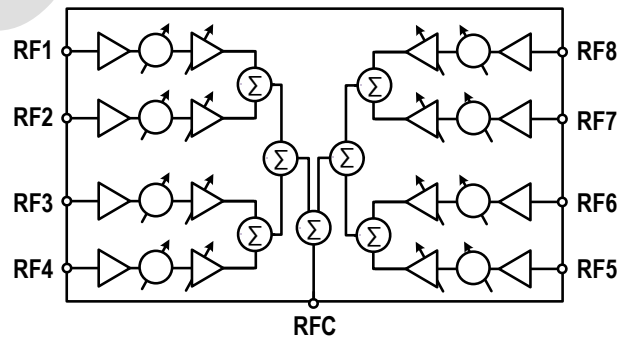

Ordering Information

| Orderable Part Number | Package | MSL Rating | Carrier Type | Temperature |
|-----------------------|--|------------|--------------|---------------|
| F6101NTGK | 5mm x 5mm 40-QFN | MSL 3 | Tray | -40° to +95°C |
| F6101NTGK8 | 5mm x 5mm 40-QFN | MSL 3 | Reel | -40° to +95°C |
| F6101EVB | Evaluation Board | | | |
| F6101EVS | F6101 Evaluation Kit System, including Evaluation Board, 2x THRU Reference Fixture, FT2232H Mini-Module Microcontroller, Digital Cable, Power Cable, and USB-to-Mini Cable | | | |



Corporate Headquarters

6024 Silver Creek Valley Road
 San Jose, CA 95138
www.IDT.com

Sales

1-800-345-7015 or 408-284-8200
 Fax: 408-284-2775
www.IDT.com/go/sales

Tech Support

www.IDT.com/go/support

DISCLAIMER Integrated Device Technology, Inc. (IDT) and its affiliated companies (herein referred to as "IDT") reserve the right to modify the products and/or specifications described herein at any time, without notice, at IDT's sole discretion. Performance specifications and operating parameters of the described products are determined in an independent state and are not guaranteed to perform the same way when installed in customer products. The information contained herein is provided without representation or warranty of any kind, whether express or implied, including, but not limited to, the suitability of IDT's products for any particular purpose, an implied warranty of merchantability, or non-infringement of the intellectual property rights of others. This document is presented only as a guide and does not convey any license under intellectual property rights of IDT or any third parties.

IDT's products are not intended for use in applications involving extreme environmental conditions or in life support systems or similar devices where the failure or malfunction of an IDT product can be reasonably expected to significantly affect the health or safety of users. Anyone using an IDT product in such a manner does so at their own risk, absent an express, written agreement by IDT.

Integrated Device Technology, IDT and the IDT logo are trademarks or registered trademarks of IDT and its subsidiaries in the United States and other countries. Other trademarks used herein are the property of IDT or their respective third party owners. For datasheet type definitions and a glossary of common terms, visit www.idt.com/go/glossary. All contents of this document are copyright of Integrated Device Technology, Inc. All rights reserved.