

## Description

The F6103 is an 8-channel receiver IC designed using a SiGe BiCMOS process for CDL phased array applications. The core IC has 6-bit phase control coupled with 30dB gain control on each channel to achieve fine beam steering and gain compensation between radiating channels. The device has 17dB nominal electric gain and -31dBm IP1dB. The core chip achieves an RMS phase error of 3° and RMS gain error of 0.3dB over the frequency of operation. The typical total power consumption is 0.32W (40mW per channel).

## Competitive Advantage

- High integration
- Orthogonality of phase and amplitude control
- Advanced Serial Peripheral Interface (SPI) with 4-state memory
- Superior channel-to-channel isolation
- Minimal footprint

## Typical Applications

- CDL Terminals
- Aerospace and Maritime
- Beam Steering
- Point-to-Point (Line-of-Sight) Communications

## Features

- 14GHz to 16GHz operation
- 8 radiation channels
- 6-bit phase control
- 20ns typical gain settling time
- 20ns typical phase settling time
- 3° typical RMS phase error
- 0.3dB typical RMS gain error
- 30dB gain attenuation range
- 5-bit IC address
- Integrated proportional-to-absolute temperature (PTAT) sensor with external biasing
- -40°C to +95°C internal temperature sensor
- Programmable 4-state on-chip memory
- Supply voltage: +2.1V to +2.5V
- -40°C to +95°C ambient operating temperature range
- 27°C typical ambient operating temperature
- 5mm x 5mm, 40-QFN package

## Block Diagram

**Figure 1. Block Diagram**

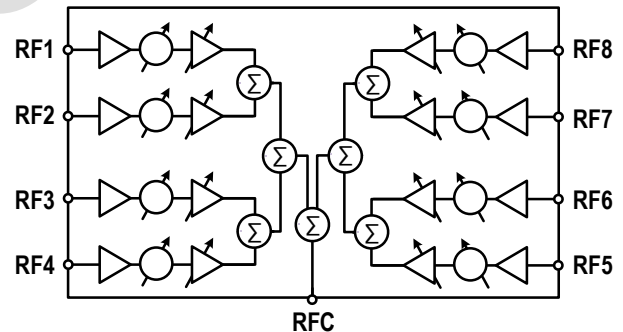

## Ordering Information

Orderable Part Number	Package	MSL Rating	Carrier Type	Temperature
F6103NTGK	5mm x 5mm 40-QFN	MSL 3	Tray	-40° to +95°C
F6103NTGK8	5mm x 5mm 40-QFN	MSL 3	Reel	-40° to +95°C
F6103EVB	Evaluation Board			
F6103EVS	F6103 Evaluation Kit System, including Evaluation Board, 2x THRU Reference Fixture, FT2232H Mini-Module Microcontroller, Digital Cable, Power Cable, and USB-to-Mini Cable			



### Corporate Headquarters

6024 Silver Creek Valley Road  
 San Jose, CA 95138  
[www.IDT.com](http://www.IDT.com)

### Sales

1-800-345-7015 or 408-284-8200  
 Fax: 408-284-2775  
[www.IDT.com/go/sales](http://www.IDT.com/go/sales)

### Tech Support

[www.IDT.com/go/support](http://www.IDT.com/go/support)

DISCLAIMER Integrated Device Technology, Inc. (IDT) and its affiliated companies (herein referred to as "IDT") reserve the right to modify the products and/or specifications described herein at any time, without notice, at IDT's sole discretion. Performance specifications and operating parameters of the described products are determined in an independent state and are not guaranteed to perform the same way when installed in customer products. The information contained herein is provided without representation or warranty of any kind, whether express or implied, including, but not limited to, the suitability of IDT's products for any particular purpose, an implied warranty of merchantability, or non-infringement of the intellectual property rights of others. This document is presented only as a guide and does not convey any license under intellectual property rights of IDT or any third parties.

IDT's products are not intended for use in applications involving extreme environmental conditions or in life support systems or similar devices where the failure or malfunction of an IDT product can be reasonably expected to significantly affect the health or safety of users. Anyone using an IDT product in such a manner does so at their own risk, absent an express, written agreement by IDT.

Integrated Device Technology, IDT and the IDT logo are trademarks or registered trademarks of IDT and its subsidiaries in the United States and other countries. Other trademarks used herein are the property of IDT or their respective third party owners. For datasheet type definitions and a glossary of common terms, visit [www.idt.com/go/glossary](http://www.idt.com/go/glossary). All contents of this document are copyright of Integrated Device Technology, Inc. All rights reserved.