

Description

The F6212 is a 16-channel dual-beam receive active beamforming RFIC multi-chip module designed for application in Ka-Band SATCOM planar phased array antennas. The IC has eight RF input ports, two RF output ports, and 16 (8 per beam) phase/amplitude control channels. The eight input ports of the IC can be driven by eight single-polarized elements or four dual-polarized elements of an electronically scanned array (ESA). Each channel has 6 bits of digital phase and gain control resolution spanning 360° and 26dB of dynamic range, enabling precise beam pattern and polarization control.

The IC operates from two supply rails of 2.1 - 2.5V and 0.95 - 1.05V with a typical channel gain of 28dB. The chip includes power management features such as a low-power standby mode, independent enable controls on every channel, and a single-beam mode activated via a dedicated control pin. An integrated Hi-Q bandpass filter provides rejection of SATCOM Tx and 5G mmWave signals, improving the dynamic range without additional power consumption. The device SPI bus and control pins operate from standard 1.8V logic at speeds up to 50MHz. Advanced digital modes and large on-chip memory allow for < 100ns beam position switching times at the array level, greatly reducing dead time and latency.

Finally, the compact and CTE-matched FCBGA organic package with all single-ended 50ohm matched RF ports and 0.5mm pitch greatly simplifies the physical integration of these devices onto large antenna panels.

Features

- 17.7 – 21.2GHz operation
- Supports 4 dual-pol or 8 single-pol elements
- Two simultaneous and independent beam outputs
- Integrated Hi-Q transmit reject filter
- 28dB typical channel gain
- 26dB gain control with 0.45dB step size
- 360° phase control with 6-bit resolution
- 2.3V and 1V nominal supply inputs
- Standard 1.8V digital logic
- Temperature compensation
- Temperature sensor w/ digital readout
- Advanced digital modes with fast beam steering
- On-chip beam-state memory
- 7.6 × 7.6 × 0.9 mm, 165-FCBGA

Typical Applications

- Phased array antennas
- Ka-Band SATCOM terminals
- Aerospace, maritime, and SOTM

Block Diagram

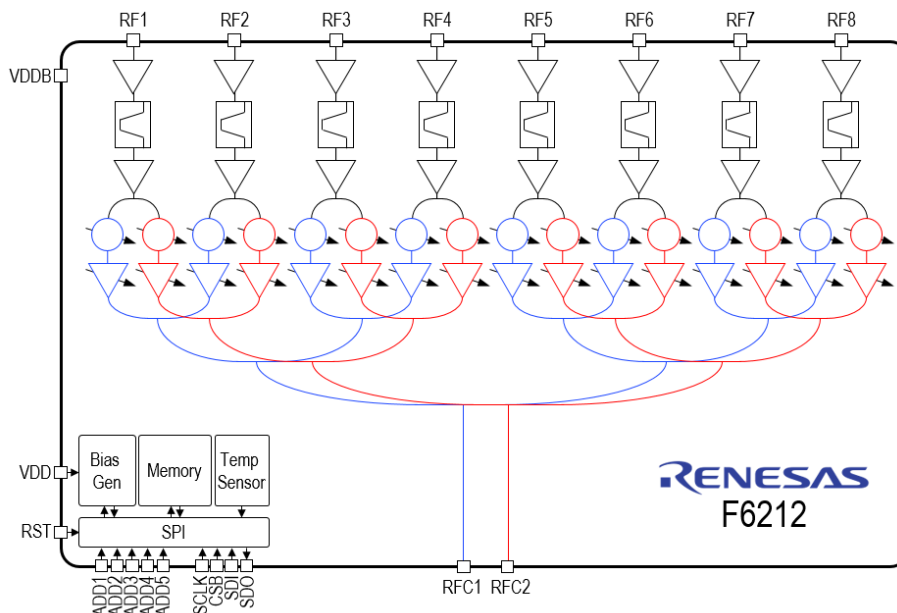

Ordering Information

Orderable Part Number	Package	MSL Rating	Carrier Type	Temperature
F6212AVGI	7.6 × 7.6 × 0.9 mm 165-BGA	3	Tray	-40°C to +85°C
F6212AVGI8	7.6 × 7.6 × 0.9 mm 165-BGA	3	Reel	-40°C to +85°C
F6212EVS	F6212 Evaluation System. Includes Digital Interface Board, RF Evaluation Board, USB Cable, Power Supply Cable, Digital Interconnect Cable, Evaluation Software, Device Drivers and RF De-embed Files.			

IMPORTANT NOTICE AND DISCLAIMER

RENESAS ELECTRONICS CORPORATION AND ITS SUBSIDIARIES (“RENESAS”) PROVIDES TECHNICAL SPECIFICATIONS AND RELIABILITY DATA (INCLUDING DATASHEETS), DESIGN RESOURCES (INCLUDING REFERENCE DESIGNS), APPLICATION OR OTHER DESIGN ADVICE, WEB TOOLS, SAFETY INFORMATION, AND OTHER RESOURCES “AS IS” AND WITH ALL FAULTS, AND DISCLAIMS ALL WARRANTIES, EXPRESS OR IMPLIED, INCLUDING, WITHOUT LIMITATION, ANY IMPLIED WARRANTIES OF MERCHANTABILITY, FITNESS FOR A PARTICULAR PURPOSE, OR NON-INFRINGEMENT OF THIRD PARTY INTELLECTUAL PROPERTY RIGHTS.

These resources are intended for developers skilled in the art designing with Renesas products. You are solely responsible for (1) selecting the appropriate products for your application, (2) designing, validating, and testing your application, and (3) ensuring your application meets applicable standards, and any other safety, security, or other requirements. These resources are subject to change without notice. Renesas grants you permission to use these resources only for development of an application that uses Renesas products. Other reproduction or use of these resources is strictly prohibited. No license is granted to any other Renesas intellectual property or to any third party intellectual property. Renesas disclaims responsibility for, and you will fully indemnify Renesas and its representatives against, any claims, damages, costs, losses, or liabilities arising out of your use of these resources. Renesas' products are provided only subject to Renesas' Terms and Conditions of Sale or other applicable terms agreed to in writing. No use of any Renesas resources expands or otherwise alters any applicable warranties or warranty disclaimers for these products.

(Disclaimer Rev.1.0 Mar 2020)

Corporate Headquarters

TOYOSU FORESIA, 3-2-24 Toyosu,
Koto-ku, Tokyo 135-0061, Japan
www.renesas.com

Contact Information

For further information on a product, technology, the most up-to-date version of a document, or your nearest sales office, please visit:
www.renesas.com/contact/

Trademarks

Renesas and the Renesas logo are trademarks of Renesas Electronics Corporation. All trademarks and registered trademarks are the property of their respective owners.