



56F801

www.datasheet4u.com

Technical Data 56F801 16-bit Hybrid Controller

- Up to 30 MIPS operation at 60MHz core frequency
- Up to 40 MIPS operation at 80MHz core frequency
- DSP and MCU functionality in a unified, C-efficient architecture
- MCU-friendly instruction set supports both DSP and controller functions: MAC, bit manipulation unit, 14 addressing modes
- Hardware DO and REP loops
- 6-channel PWM Module
- Two 4-channel, 12-bit ADCs
- Serial Communications Interface (SCI)
- 8K × 16-bit words Program Flash
- 1K × 16-bit words Program RAM
- 2K × 16-bit words Data Flash
- 1K × 16-bit words Data RAM
- 2K × 16-bit words Boot Flash
- Serial Peripheral Interface (SPI)
- General Purpose Quad Timer
- JTAG/OnCE™ port for debugging
- On-chip relaxation oscillator
- 11 shared GPIO
- 48-pin LQFP Package

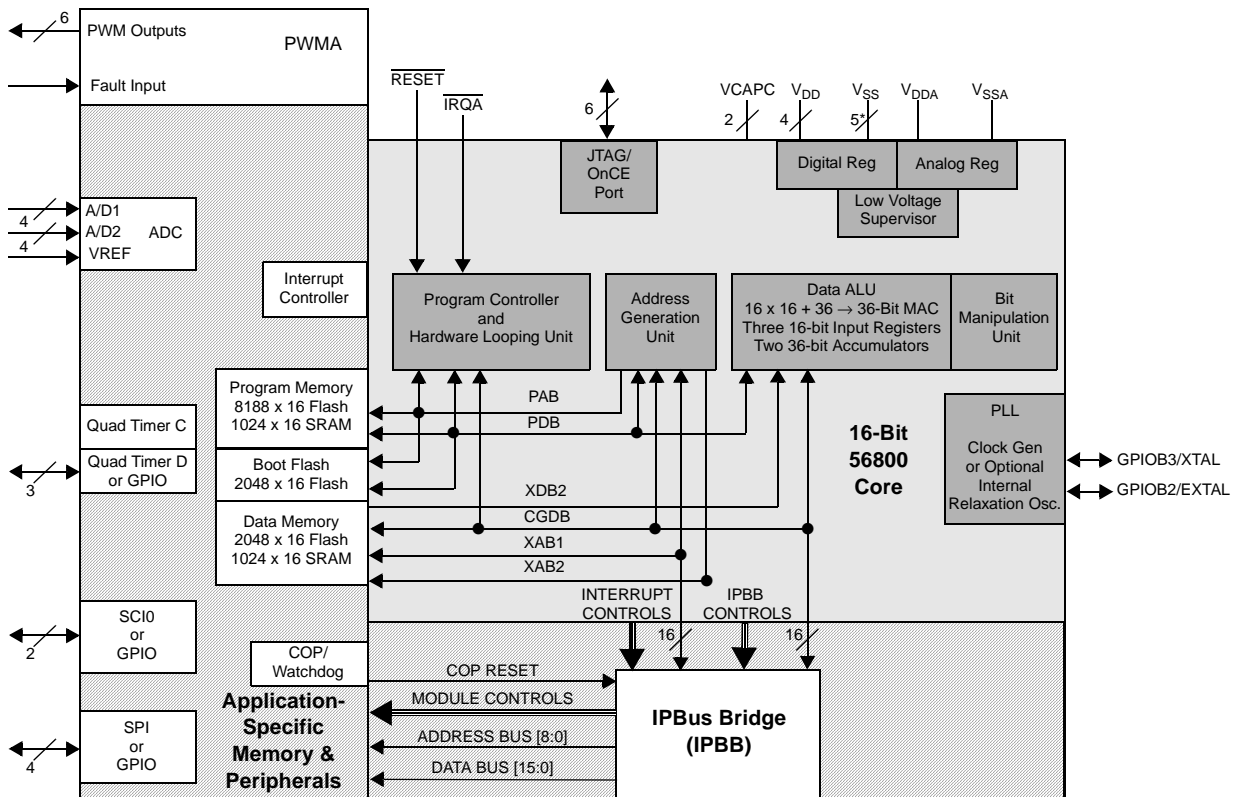

*includes TCS pin which is reserved for factory use and is tied to VSS

Figure 1. 56F801 Block Diagram

Part 1 Overview

1.1 56F801 Features

www.datasheet4u.com

1.1.1 Digital Signal Processing Core

- Efficient 16-bit 56800 family hybrid controller engine with dual Harvard architecture
- As many as 40 Million Instructions Per Second (MIPS) at 80MHz core frequency
- Single-cycle 16×16 -bit parallel Multiplier-Accumulator (MAC)
- Two 36-bit accumulators including extension bits
- 16-bit bidirectional barrel shifter
- Parallel instruction set with unique DSP addressing modes
- Hardware DO and REP loops
- Three internal address buses and one external address bus
- Four internal data buses and one external data bus
- Instruction set supports both DSP and controller functions
- Controller style addressing modes and instructions for compact code
- Efficient C compiler and local variable support
- Software subroutine and interrupt stack with depth limited only by memory
- JTAG/OnCE debug programming interface

1.1.2 Memory

- Harvard architecture permits as many as three simultaneous accesses to Program and Data memory
- On-chip memory including a low-cost, high-volume Flash solution
 - $8K \times 16$ bit words of Program Flash
 - $1K \times 16$ -bit words of Program RAM
 - $2K \times 16$ -bit words of Data Flash
 - $1K \times 16$ -bit words of Data RAM
 - $2K \times 16$ -bit words of Boot Flash
- Programmable Boot Flash supports customized boot code and field upgrades of stored code through a variety of interfaces (JTAG, SPI)

1.1.3 Peripheral Circuits for 56F801

- Pulse Width Modulator (PWM) with six PWM outputs, two Fault inputs, fault-tolerant design with deadtime insertion; supports both center- and edge-aligned modes
- Two 12-bit, Analog-to-Digital Converters (ADCs), which support two simultaneous conversions with two 4-multiplexed inputs; ADC and PWM modules can be synchronized
- General Purpose Quad Timer: Timer D with three pins (or three additional GPIO lines)
- Serial Communication Interface (SCI) with two pins (or two additional GPIO lines)
- Serial Peripheral Interface (SPI) with configurable four-pin port (or four additional GPIO lines)

- Eleven multiplexed General Purpose I/O (GPIO) pins
- Computer-Operating Properly (COP) watchdog timer
- One dedicated external interrupt pin
- External reset pin for hardware reset
- JTAG/On-Chip Emulation (OnCE™) for unobtrusive, processor speed-independent debugging
- Software-programmable, Phase Locked Loop-based frequency synthesizer for the hybrid controller core clock
- Oscillator flexibility between either an external crystal oscillator or an on-chip relaxation oscillator for lower system cost and two additional GPIO lines

1.1.4 Energy Information

- Fabricated in high-density CMOS with 5V-tolerant, TTL-compatible digital inputs
- Uses a single 3.3V power supply
- On-chip regulators for digital and analog circuitry to lower cost and reduce noise
- Wait and Stop modes available

1.2 56F801 Description

The 56F801 is a member of the 56800 core-based family of hybrid controllers. It combines, on a single chip, the processing power of a DSP and the functionality of a microcontroller with a flexible set of peripherals to create an extremely cost-effective solution. Because of its low cost, configuration flexibility, and compact program code, the 56F801 is well-suited for many applications. The 56F801 includes many peripherals that are especially useful for applications such as motion control, smart appliances, steppers, encoders, tachometers, limit switches, power supply and control, automotive control, engine management, noise suppression, remote utility metering, and industrial control for power, lighting, and automation.

The 56800 core is based on a Harvard-style architecture consisting of three execution units operating in parallel, allowing as many as six operations per instruction cycle. The microprocessor-style programming model and optimized instruction set allow straightforward generation of efficient, compact code for both DSP and MCU applications. The instruction set is also highly efficient for C compilers to enable rapid development of optimized control applications.

The 56F801 supports program execution from either internal or external memories. Two data operands can be accessed from the on-chip Data RAM per instruction cycle. The 56F801 also provides one external dedicated interrupt lines and up to 11 General Purpose Input/Output (GPIO) lines, depending on peripheral configuration.

The 56F801 controller includes 8K words (16-bit) of Program Flash and 2K words of Data Flash (each programmable through the JTAG port) with 1K words of both Program and Data RAM. A total of 2K words of Boot Flash is incorporated for easy customer-inclusion of field-programmable software routines that can be used to program the main Program and Data Flash memory areas. Both Program and Data Flash memories can be independently bulk erased or erased in page sizes of 256 words. The Boot Flash memory can also be either bulk or page erased.

A key application-specific feature of the 56F801 is the inclusion of a Pulse Width Modulator (PWM) module. This module incorporates six complementary, individually programmable PWM signal outputs to enhance motor control functionality. Complementary operation permits programmable dead-time insertion,

and separate top and bottom output polarity control. The up-counter value is programmable to support a continuously variable PWM frequency. Both edge- and center-aligned synchronous pulse width control (0% to 100% modulation) are supported. The device is capable of controlling most motor types: ACIM (AC Induction Motors), both BDC and BLDC (Brush and Brushless DC motors), SRM and VRM (Switched and Variable Reluctance Motors), and stepper motors. The PWMs incorporate fault protection and cycle-by-cycle current limiting with sufficient output drive capability to directly drive standard opto-isolators. A “smoke-inhibit”, write-once protection feature for key parameters is also included. The PWM is double-buffered and includes interrupt control to permit integral reload rates to be programmable from 1 to 16. The PWM modules provide a reference output to synchronize the Analog-to-Digital Converters.

The 56F801 incorporates an 8 input, 12-bit Analog-to-Digital Converter (ADC). A full set of standard programmable peripherals is provided that include a Serial Communications Interface (SCI), a Serial Peripheral Interface (SPI), and two Quad Timers. Any of these interfaces can be used as General-Purpose Input/Outputs (GPIO) if that function is not required. An on-chip relaxation oscillator provides flexibility in the choice of either on-chip or externally supplied frequency reference for chip timing operations. Application code is used to select which source is to be used.

1.3 State of the Art Development Environment

- Processor Expert™ (PE) provides a Rapid Application Design (RAD) tool that combines easy-to-use component-based software application creation with an expert knowledge system.
- The Code Warrior Integrated Development Environment is a sophisticated tool for code navigation, compiling, and debugging. A complete set of evaluation modules (EVMs) and development system cards will support concurrent engineering. Together, PE, Code Warrior and EVMs create a complete, scalable tools solution for easy, fast, and efficient development.

1.4 Product Documentation

The four documents listed in **Table 1** are required for a complete description and proper design with the 56F801. Documentation is available from local Motorola distributors, Motorola semiconductor sales offices, Motorola Literature Distribution Centers, or online at www.motorola.com/semiconductors.

Table 1. 56F801 Chip Documentation

Topic	Description	Order Number
DSP56800 Family Manual	Detailed description of the 56800 family architecture, and 16-bit core processor and the instruction set	DSP56800FM/D
DSP56F801/803/805/807 User's Manual	Detailed description of memory, peripherals, and interfaces of the 56F801, 56F803, 56F805, and 56F807	DSP56F801-7UM/D
56F801 Technical Data Sheet	Electrical and timing specifications, pin descriptions, and package descriptions (this document)	DSP56F801/D
56F801 Product Brief	Summary description and block diagram of the 56F801 core, memory, peripherals and interfaces	DSP56F801PB/D
DSP56F801 Errata	Details any chip issues that might be present	DSP56F801E/D

1.5 Data Sheet Conventions

This data sheet uses the following conventions:

$\overline{\text{OVERBAR}}$ This is used to indicate a signal that is active when pulled low. For example, the $\overline{\text{RESET}}$ pin is active when low.

www.datasheet4u.com

“asserted” A high true (active high) signal is high or a low true (active low) signal is low.

“deasserted” A high true (active high) signal is low or a low true (active low) signal is high.

Examples:	Signal/Symbol	Logic State	Signal State	Voltage ¹
	$\overline{\text{PIN}}$	True	Asserted	$V_{\text{IL}}/V_{\text{OL}}$
	$\overline{\text{PIN}}$	False	Deasserted	$V_{\text{IH}}/V_{\text{OH}}$
	PIN	True	Asserted	$V_{\text{IH}}/V_{\text{OH}}$
	PIN	False	Deasserted	$V_{\text{IL}}/V_{\text{OL}}$

1. Values for V_{IL} , V_{OL} , V_{IH} , and V_{OH} are defined by individual product specifications.

Part 2 Signal/Connection Descriptions

2.1 Introduction

The input and output signals of the 56F801 are organized into functional groups, as shown in [Table 2](#) and as illustrated in [Figure 2](#). In [Table 3](#) through [Table 13](#), each table row describes the signal or signals present on a pin.

Table 2. Functional Group Pin Allocations

Functional Group	Number of Pins	Detailed Description
Power (V_{DD} or V_{DDA})	5	Table 3
Ground (V_{SS} or V_{SSA})	6	Table 4
Supply Capacitors	2	Table 5
PLL and Clock	2	Table 6
Interrupt and Program Control	2	Table 7
Pulse Width Modulator (PWM) Port	7	Table 8
Serial Peripheral Interface (SPI) Port ¹	4	Table 9
Serial Communications Interface (SCI) Port ¹	2	Table 10
Analog-to-Digital Converter (ADC) Port	9	Table 11
Quad Timer Module Port	3	Table 12
JTAG/On-Chip Emulation (OnCE)	6	Table 13

1. Alternately, GPIO pins

www.datasheet4u.com

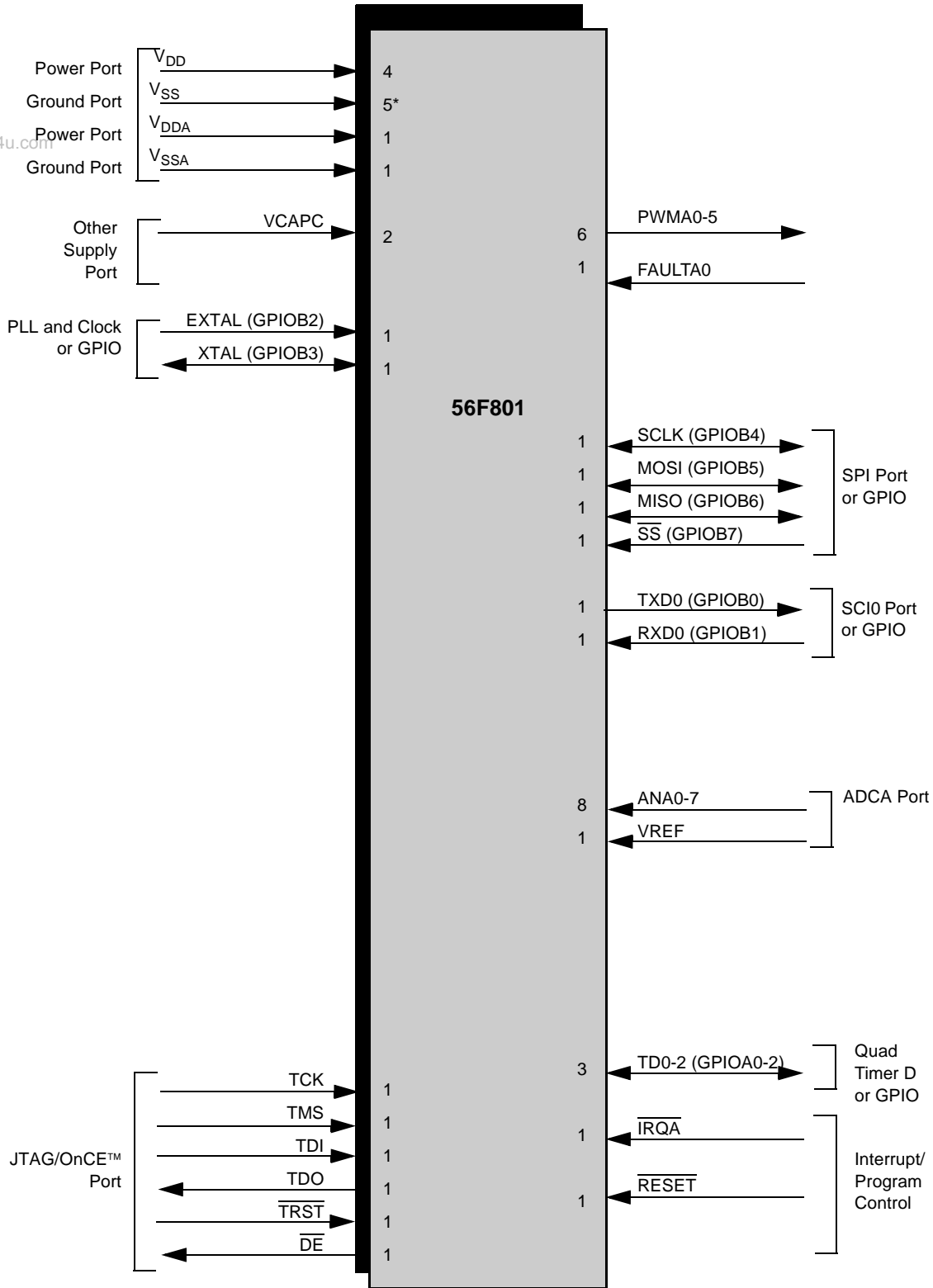

*includes TCS pin which is reserved for factory use and is tied to VSS

Figure 2. 56F801 Signals Identified by Functional Group¹

1. Alternate pin functionality is shown in parenthesis.

2.2 Power and Ground Signals

Table 3. Power Inputs

No. of Pins	Signal Name	Signal Description
4	V _{DD}	Power —These pins provide power to the internal structures of the chip, and should all be attached to V _{DD} .
1	V _{DDA}	Analog Power —This pin is a dedicated power pin for the analog portion of the chip and should be connected to a low noise 3.3V supply.

Table 4. Grounds

No. of Pins	Signal Name	Signal Description
4	V _{SS}	GND —These pins provide grounding for the internal structures of the chip, and should all be attached to V _{SS} .
1	V _{SSA}	Analog Ground —This pin supplies an analog ground.
1	TCS	TCS —This Schmitt pin is reserved for factory use and must be tied to V _{SS} for normal use. In block diagrams, this pin is considered an additional V _{SS} .

Table 5. Supply Capacitors and VPP

No. of Pins	Signal Name	Signal Type	State During Reset	Signal Description
2	VCAPC	Supply	Supply	VCAPC —Connect each pin to a 2.2 μF or greater bypass capacitor in order to bypass the core logic voltage regulator (required for proper chip operation). For more information, refer to Section 5.2 .

2.3 Clock and Phase Locked Loop Signals

Table 6. PLL and Clock

No. of Pins	Signal Name	Signal Type	State During Reset	Signal Description
1	EXTAL	Input	Input	External Crystal Oscillator Input —This input should be connected to an 8MHz external crystal or ceramic resonator. For more information, please refer to Section 3.5 .
	GPIOB2	Input/Output	Input	Port B GPIO —This multiplexed pin is a General Purpose I/O (GPIO) pin that can be programmed as an input or output pin. This I/O can be utilized when using the on-chip relaxation oscillator so the EXTAL pin is not needed.

Table 6. PLL and Clock (Continued)

No. of Pins	Signal Name	Signal Type	State During Reset	Signal Description
1	XTAL	Output	Chip-driven	Crystal Oscillator Output —This output should be connected to an 8MHz external crystal or ceramic resonator. For more information, please refer to Section 3.5 . This pin can also be connected to an external clock source. For more information, please refer to Section 3.5.3 .
	GPIOB3	Input/Output	Input	Port B GPIO —This multiplexed pin is a General Purpose I/O (GPIO) pin that can be programmed as an input or output pin. This I/O can be utilized when using the on-chip relaxation oscillator so the XTAL pin is not needed.

2.4 Interrupt and Program Control Signals

Table 7. Interrupt and Program Control Signals

No. of Pins	Signal Name	Signal Type	State During Reset	Signal Description
1	$\overline{\text{IRQA}}$	Input (Schmitt)	Input	External Interrupt Request A —The $\overline{\text{IRQA}}$ input is a synchronized external interrupt request that indicates that an external device is requesting service. It can be programmed to be level-sensitive or negative-edge-triggered.
1	$\overline{\text{RESET}}$	Input (Schmitt)	Input	Reset —This input is a direct hardware reset on the processor. When $\overline{\text{RESET}}$ is asserted low, the hybrid controller is initialized and placed in the Reset state. A Schmitt trigger input is used for noise immunity. When the $\overline{\text{RESET}}$ pin is deasserted, the initial chip operating mode is latched from the EXTBOOT pin. The internal reset signal will be deasserted synchronous with the internal clocks, after a fixed number of internal clocks. To ensure complete hardware reset, $\overline{\text{RESET}}$ and $\overline{\text{TRST}}$ should be asserted together. The only exception occurs in a debugging environment when a hardware device reset is required and it is necessary not to reset the OnCE/JTAG module. In this case, assert $\overline{\text{RESET}}$, but do not assert $\overline{\text{TRST}}$.

2.5 Pulse Width Modulator (PWM) Signals

Table 8. Pulse Width Modulator (PWMA) Signals

No. of Pins	Signal Name	Signal Type	State During Reset	Signal Description
6	PWMA0-5	Output	Tri-stated	PWMA0-5 — These are six PWMA output pins.
1	FAULTA0	Input (Schmitt)	Input	FAULTA0 — This fault input pin is used for disabling selected PWMA outputs in cases where fault conditions originate off-chip.

2.6 Serial Peripheral Interface (SPI) Signals

Table 9. Serial Peripheral Interface (SPI) Signals

No. of Pins	Signal Name	Signal Type	State During Reset	Signal Description
1	MISO	Input/Output	Input	SPI Master In/Slave Out (MISO) —This serial data pin is an input to a master device and an output from a slave device. The MISO line of a slave device is placed in the high-impedance state if the slave device is not selected.
	GPIOB6	Input/Output	Input	Port E GPIO —This pin is a General Purpose I/O (GPIO) pin that can be individually programmed as input or output pin. After reset, the default state is MISO.
1	MOSI	Input/Output	Input	SPI Master Out/Slave In (MOSI) —This serial data pin is an output from a master device and an input to a slave device. The master device places data on the MOSI line a half-cycle before the clock edge that the slave device uses to latch the data.
	GPIOB5	Input/Output	Input	Port E GPIO —This pin is a General Purpose I/O (GPIO) pin that can be individually programmed as input or output pin. After reset, the default state is MOSI.
1	SCLK	Input/Output	Input	SPI Serial Clock —In master mode, this pin serves as an output, clocking slaved listeners. In slave mode, this pin serves as the data clock input.
	GPIOB4	Input/Output	Input	Port E GPIO —This pin is a General Purpose I/O (GPIO) pin that can be individually programmed as an input or output pin. After reset, the default state is SCLK.
1	SS	Input	Input	SPI Slave Select —In master mode, this pin is used to arbitrate multiple masters. In slave mode, this pin is used to select the slave.
	GPIOB7	Input/Output	Input	Port E GPIO —This pin is a General Purpose I/O (GPIO) pin that can be individually programmed as an input or output pin. After reset, the default state is \overline{SS} .

2.7 Serial Communications Interface (SCI) Signals

Table 10. Serial Communications Interface (SCI0) Signals

No. of Pins	Signal Name	Signal Type	State During Reset	Signal Description
1	TXD0	Output	Input	Transmit Data (TXD0) —SCI0 transmit data output
	GPIOB0	Input/Output	Input	Port B GPIO —This pin is a General Purpose I/O (GPIO) pin that can be individually programmed as an input or output pin. After reset, the default state is SCI output.
1	RXD0	Input	Input	Receive Data (RXD0) —SCI0 receive data input
	GPIOB1	Input/Output	Input	Port B GPIO —This pin is a General Purpose I/O (GPIO) pin that can be individually programmed as an input or output pin. After reset, the default state is SCI input.

2.8 Analog-to-Digital Converter (ADC) Signals

Table 11. Analog to Digital Converter Signals

No. of Pins	Signal Name	Signal Type	State During Reset	Signal Description
4	ANA0-3	Input	Input	ANA0-3 —Analog inputs to ADC, channel 1
4	ANA4-7	Input	Input	ANA4-7 —Analog inputs to ADC, channel 2
1	VREF	Input	Input	VREF —Analog reference voltage for ADC. Must be set to $V_{DDA}-0.3V$ for optimal performance.

2.9 Quad Timer Module Signals

Table 12. Quad Timer Module Signals

No. of Pins	Signal Name	Signal Type	State During Reset	Signal Description
3	TD0-2	Input/Output	Input	TD0-2 —Timer D Channel 0-2
	GPIOA0-2	Input/Output	Input	Port A GPIO —This pin is a General Purpose I/O (GPIO) pin that can be individually programmed as an input or output pin. After reset, the default state is the quad timer input.

2.10 JTAG/OnCE

Table 13. JTAG/On-Chip Emulation (OnCE) Signals

No. of Pins	Signal Name	Signal Type	State During Reset	Signal Description
1	TCK	Input (Schmitt)	Input, pulled low internally	Test Clock Input —This input pin provides a gated clock to synchronize the test logic and shift serial data to the JTAG/OnCE port. The pin is connected internally to a pull-down resistor.
1	TMS	Input (Schmitt)	Input, pulled high internally	Test Mode Select Input —This input pin is used to sequence the JTAG TAP controller's state machine. It is sampled on the rising edge of TCK and has an on-chip pull-up resistor.
1	TDI	Input (Schmitt)	Input, pulled high internally	Test Data Input —This input pin provides a serial input data stream to the JTAG/OnCE port. It is sampled on the rising edge of TCK and has an on-chip pull-up resistor.
1	TDO	Output	Tri-stated	Test Data Output —This tri-statable output pin provides a serial output data stream from the JTAG/OnCE port. It is driven in the Shift-IR and Shift-DR controller states, and changes on the falling edge of TCK.
1	$\overline{\text{TRST}}$	Input (Schmitt)	Input, pulled high internally	Test Reset —As an input, a low signal on this pin provides a reset signal to the JTAG TAP controller. To ensure complete hardware reset, $\overline{\text{TRST}}$ should be asserted whenever RESET is asserted. The only exception occurs in a debugging environment when a hardware device reset is required and it is necessary not to reset the OnCE/JTAG module. In this case, assert RESET, but do not assert $\overline{\text{TRST}}$.
1	$\overline{\text{DE}}$	Output	Output	Debug Event — $\overline{\text{DE}}$ provides a low pulse on recognized debug events.

Part 3 Specifications

3.1 General Characteristics

The 56F801 is fabricated in high-density CMOS with 5-volt tolerant TTL-compatible digital inputs. The term “5-volt tolerant” refers to the capability of an I/O pin, built on a 3.3V compatible process technology, to withstand a voltage up to 5.5V without damaging the device. Many systems have a mixture of devices designed for 3.3V and 5V power supplies. In such systems, a bus may carry both 3.3V and 5V-compatible I/O voltage levels (a standard 3.3V I/O is designed to receive a maximum voltage of $3.3\text{V} \pm 10\%$ during normal operation without causing damage). This 5V-tolerant capability therefore offers the power savings of 3.3V I/O levels while being able to receive 5V levels without being damaged.

Absolute maximum ratings given in [Table 14](#) are stress ratings only, and functional operation at the maximum is not guaranteed. Stress beyond these ratings may affect device reliability or cause permanent damage to the device.

The 56F801 DC and AC electrical specifications are preliminary and are from design simulations. These specifications may not be fully tested or guaranteed at this early stage of the product life cycle. Finalized specifications will be published after complete characterization and device qualifications have been completed.

CAUTION

This device contains protective circuitry to guard against damage due to high static voltage or electrical fields. However, normal precautions are advised to avoid application of any voltages higher than maximum rated voltages to this high-impedance circuit. Reliability of operation is enhanced if unused inputs are tied to an appropriate voltage level.

www.datasheet4u.com

Table 14. Absolute Maximum Ratings

Characteristic	Symbol	Min	Max	Unit
Supply voltage	V_{DD}	$V_{SS} - 0.3$	$V_{SS} + 4.0$	V
All other input voltages, excluding Analog inputs	V_{IN}	$V_{SS} - 0.3$	$V_{SS} + 5.5V$	V
Analog inputs ANA0-7 and VREF	V_{IN}	$V_{SSA} - 0.3$	$V_{DDA} + 0.3$	V
Analog inputs EXTAL, XTAL	V_{IN}	$V_{SSA} - 0.3$	$V_{SSA} + 3.0$	V
Current drain per pin excluding V_{DD} , V_{SS} , & PWM outputs	I	—	10	mA

Table 15. Recommended Operating Conditions

Characteristic	Symbol	Min	Typ	Max	Unit
Supply voltage, digital	V_{DD}	3.0	3.3	3.6	V
Supply Voltage, analog	V_{DDA}	3.0	3.3	3.6	V
ADC reference voltage	VREF	2.7	—	V_{DDA}	V
Ambient operating temperature	T_A	-40	—	85	°C

Table 16. Thermal Characteristics⁶

Characteristic	Comments	Symbol	Value	Unit	Notes
			48-pin LQFP		
Junction to ambient Natural convection		$R_{\theta JA}$	50.6	°C/W	2
Junction to ambient (@1m/sec)		$R_{\theta JMA}$	47.4	°C/W	2
Junction to ambient Natural convection	Four layer board (2s2p)	$R_{\theta JMA}$ (2s2p)	39.1	°C/W	1,2
Junction to ambient (@1m/sec)	Four layer board (2s2p)	$R_{\theta JMA}$	37.9	°C/W	1,2
Junction to case		$R_{\theta JC}$	17.3	°C/W	3
Junction to center of case		Ψ_{JT}	1.2	°C/W	4, 5
I/O pin power dissipation		$P_{I/O}$	User Determined	W	
Power dissipation		P_D	$P_D = (I_{DD} \times V_{DD} + P_{I/O})$	W	
Junction to center of case		$P_{D_{MAX}}$	$(T_J - T_A) / \theta_{JA}$	°C	

Notes:

1. Theta-JA determined on 2s2p test boards is frequently lower than would be observed in an application. Determined on 2s2p thermal test board.
2. Junction to ambient thermal resistance, Theta-JA ($R_{\theta JA}$) was simulated to be equivalent to the JEDEC specification JESD51-2 in a horizontal configuration in natural convection. Theta-JA was also simulated on a thermal test board with two internal planes (2s2p where s is the number of signal layers and p is the number of planes) per JESD51-6 and JESD51-7. The correct name for Theta-JA for forced convection or with the non-single layer boards is Theta-JMA.
3. Junction to case thermal resistance, Theta-JC ($R_{\theta JC}$), was simulated to be equivalent to the measured values using the cold plate technique with the cold plate temperature used as the "case" temperature. The basic cold plate measurement technique is described by MIL-STD 883D, Method 1012.1. This is the correct thermal metric to use to calculate thermal performance when the package is being used with a heat sink.
4. Thermal Characterization Parameter, Psi-JT (Ψ_{JT}), is the "resistance" from junction to reference point thermocouple on top center of case as defined in JESD51-2. Ψ_{JT} is a useful value to use to estimate junction temperature in steady state customer environments.
5. Junction temperature is a function of on-chip power dissipation, package thermal resistance, mounting site (board) temperature, ambient temperature, air flow, power dissipation of other components on the board, and board thermal resistance.
6. See Section 5.1 from more details on thermal design considerations.

3.2 DC Electrical Characteristics

Table 17. DC Electrical Characteristics

Operating Conditions: $V_{SS} = V_{SSA} = 0\text{ V}$, $V_{DD} = V_{DDA} = 3.0\text{--}3.6\text{ V}$, $T_A = -40^\circ\text{ to }+85^\circ\text{C}$, $C_L \leq 50\text{ pF}$

Characteristic	Symbol	Min	Typ	Max	Unit
Input high voltage (XTAL/EXTAL)	V_{IHC}	2.25	—	2.75	V
Input low voltage (XTAL/EXTAL)	V_{ILC}	0	—	0.5	V
Input high voltage [GPIOB(2:3)] ¹	$V_{IH[GPIOB(2:3)]}$	2.0	—	3.6	V
Input low voltage [GPIOB(2:3)] ¹	$V_{IL[GPIOB(2:3)]}$	-0.3	—	0.8	V
Input high voltage (Schmitt trigger inputs) ²	V_{IHS}	2.2	—	5.5	V
Input low voltage (Schmitt trigger inputs) ²	V_{ILS}	-0.3	—	0.8	V
Input high voltage (all other digital inputs)	V_{IH}	2.0	—	5.5	V
Input low voltage (all other digital inputs)	V_{IL}	-0.3	—	0.8	V
Input current high (pullup/pulldown resistors disabled, $V_{IN}=V_{DD}$)	I_{IH}	-1	—	1	μA
Input current low (pullup/pulldown resistors disabled, $V_{IN}=V_{SS}$)	I_{IL}	-1	—	1	μA
Input current high (with pullup resistor, $V_{IN}=V_{DD}$)	I_{IHPU}	-1	—	1	μA
Input current low (with pullup resistor, $V_{IN}=V_{SS}$)	I_{ILPU}	-210	—	-50	μA
Input current high (with pulldown resistor, $V_{IN}=V_{DD}$)	I_{IHDP}	20	—	180	μA
Input current low (with pulldown resistor, $V_{IN}=V_{SS}$)	I_{ILD}	-1	—	1	μA
Nominal pullup or pulldown resistor value	R_{PU}, R_{PD}		30		$\text{K}\Omega$
Output tri-state current low	I_{OZL}	-10	—	10	μA
Output tri-state current high	I_{OZH}	-10	—	10	μA
Input current high (analog inputs, $V_{IN}=V_{DDA}$) ³	I_{IHA}	-15	—	15	μA
Input current low (analog inputs, $V_{IN}=V_{SSA}$) ³	I_{ILA}	-15	—	15	μA
Output High Voltage (at I_{OH})	V_{OH}	$V_{DD} - 0.7$	—	—	V
Output Low Voltage (at I_{OL})	V_{OL}	—	—	0.4	V
Output source current	I_{OH}	4	—	—	mA
Output sink current	I_{OL}	4	—	—	mA
PWM pin output source current ⁴	I_{OHP}	10	—	—	mA

Table 17. DC Electrical Characteristics (Continued)

Operating Conditions: $V_{SS} = V_{SSA} = 0\text{ V}$, $V_{DD} = V_{DDA} = 3.0\text{--}3.6\text{ V}$, $T_A = -40^\circ\text{ to }+85^\circ\text{ C}$, $C_L \leq 50\text{ pF}$

Characteristic	Symbol	Min	Typ	Max	Unit
PWM pin output sink current ⁵	I_{OLP}	16	—	—	mA
Input capacitance	C_{IN}	—	8	—	pF
Output capacitance	C_{OUT}	—	12	—	pF
V_{DD} supply current	I_{DDT} ⁶				
Run ⁷ (80MHz operation)		—	120	130	mA
Run ⁷ (60MHz operation)		—	102	111	mA
Wait ⁸		—	96	102	mA
Stop		—	62	70	mA
Low Voltage Interrupt, external power supply ⁹	V_{EIO}	2.4	2.7	3.0	V
Low Voltage Interrupt, internal power supply ¹⁰	V_{EIC}	2.0	2.2	2.4	V
Power on Reset ¹¹	V_{POR}	—	1.7	2.0	V

- Since the GPIOB[2:3] signals are shared with the XTAL/EXTAL function, these inputs are not 5.5 volt tolerant.
- Schmitt Trigger inputs are: FAULTA0, \overline{IRQA} , \overline{RESET} , TCS, TCK, TMS, TDI, and \overline{TRST} .
- Analog inputs are: ANA[0:7], XTAL and EXTAL. Specification assumes ADC is not sampling.
- PWM pin output source current measured with 50% duty cycle.
- PWM pin output sink current measured with 50% duty cycle.
- $I_{DDT} = I_{DD} + I_{DDA}$ (Total supply current for $V_{DD} + V_{DDA}$)
- Run (operating) I_{DD} measured using 8MHz clock source. All inputs 0.2V from rail; outputs unloaded. All ports configured as inputs; measured with all modules enabled.
- Wait I_{DD} measured using external square wave clock source ($f_{osc} = 8\text{ MHz}$) into XTAL; all inputs 0.2V from rail; no DC loads; less than 50pF on all outputs. $C_L = 20\text{ pF}$ on EXTAL; all ports configured as inputs; EXTAL capacitance linearly affects wait I_{DD} ; measured with PLL enabled.
- This low voltage interrupt monitors the V_{DDA} external power supply. V_{DDA} is generally connected to the same potential as V_{DD} via separate traces. If V_{DDA} drops below V_{EIO} , an interrupt is generated. Functionality of the device is guaranteed under transient conditions when $V_{DDA} \geq V_{EIO}$ (between the minimum specified V_{DD} and the point when the V_{EIO} interrupt is generated).
- This low voltage interrupt monitors the internally regulated core power supply. If the output from the internal voltage is regulator drops below V_{EIC} , an interrupt is generated. Since the core logic supply is internally regulated, this interrupt will not be generated unless the external power supply drops below the minimum specified value (3.0V).
- Power-on reset occurs whenever the internally regulated 2.5V digital supply drops below 1.5V typical. While power is ramping up, this signal remains active for as long as the internal 2.5V is below 1.5V typical no matter how long the ramp up rate is. The internally regulated voltage is typically 100 mV less than V_{DD} during ramp up until 2.5V is reached, at which time it self regulates.

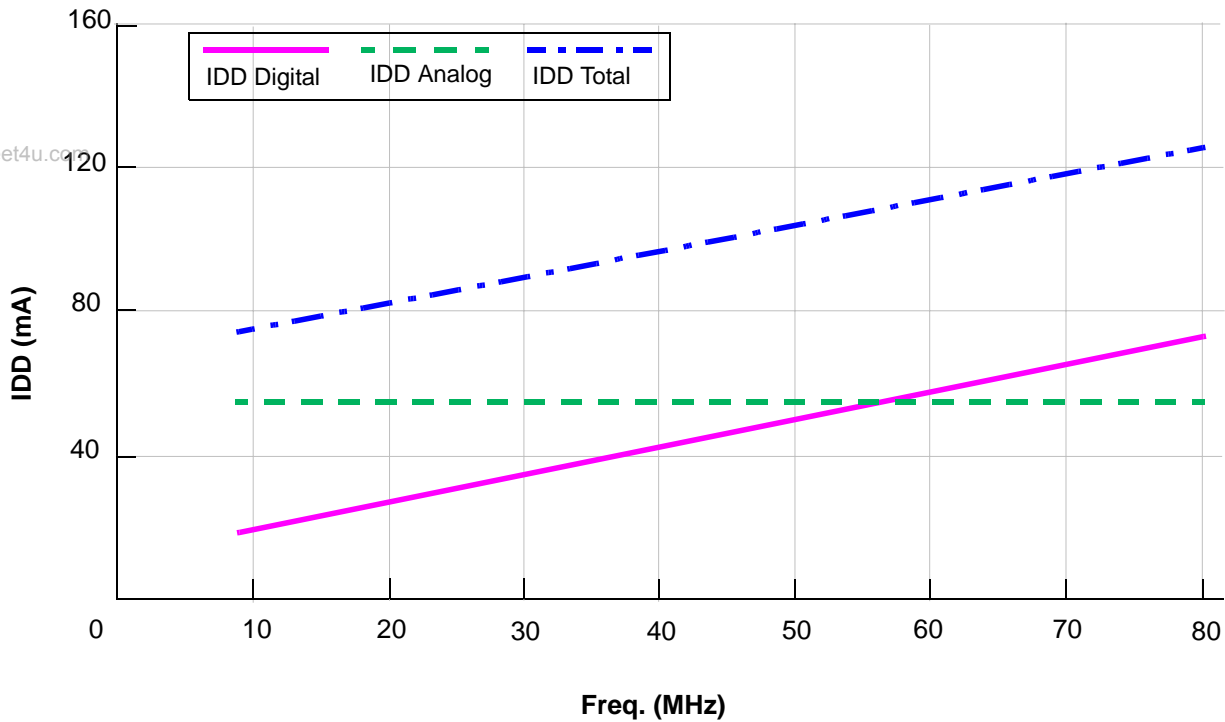
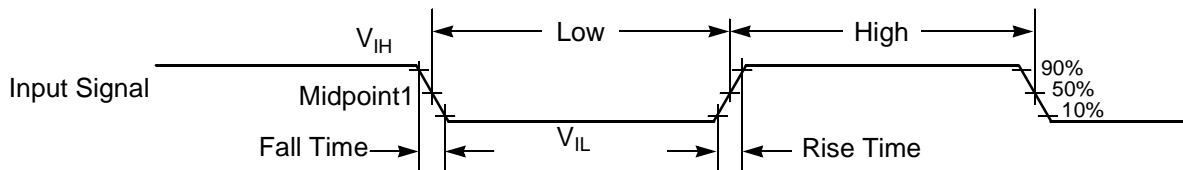

Figure 3. Maximum Run IDD vs. Frequency (see Note 7. in Table 17)

3.3 AC Electrical Characteristics

Timing waveforms in Section 3.3 are tested using the V_{IL} and V_{IH} levels specified in the DC Characteristics table. In Figure 4 the levels of V_{IH} and V_{IL} for an input signal are shown.



Note: The midpoint is $V_{IL} + (V_{IH} - V_{IL})/2$.

Figure 4. Input Signal Measurement References

Figure 5 shows the definitions of the following signal states:

- Active state, when a bus or signal is driven, and enters a low impedance state.
- Tri-stated, when a bus or signal is placed in a high impedance state.
- Data Valid state, when a signal level has reached V_{OL} or V_{OH} .
- Data Invalid state, when a signal level is in transition between V_{OL} and V_{OH} .

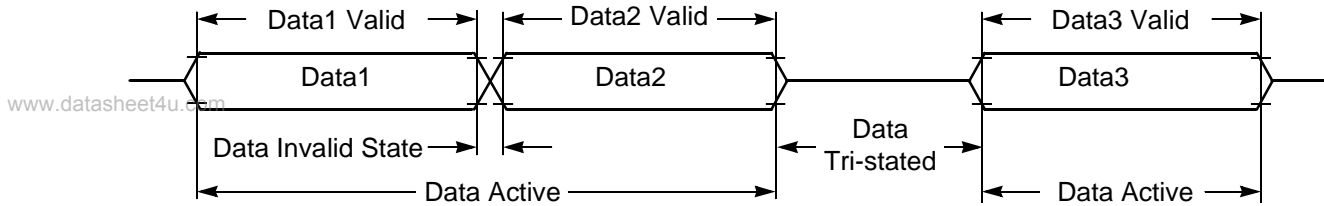

Figure 5. Signal States

3.4 Flash Memory Characteristics

Table 18. Flash Memory Truth Table

Mode	XE ¹	YE ²	SE ³	OE ⁴	PROG ⁵	ERASE ⁶	MAS1 ⁷	NVSTR ⁸
Standby	L	L	L	L	L	L	L	L
Read	H	H	H	H	L	L	L	L
Word Program	H	H	L	L	H	L	L	H
Page Erase	H	L	L	L	L	H	L	H
Mass Erase	H	L	L	L	L	H	H	H

1. X address enable, all rows are disabled when XE = 0
2. Y address enable, YMUX is disabled when YE = 0
3. Sense amplifier enable
4. Output enable, tri-state Flash data out bus when OE = 0
5. Defines program cycle
6. Defines erase cycle
7. Defines mass erase cycle, erase whole block
8. Defines non-volatile store cycle

Table 19. IFREN Truth Table

Mode	IFREN = 1	IFREN = 0
Read	Read information block	Read main memory block
Word program	Program information block	Program main memory block
Page erase	Erase information block	Erase main memory block
Mass erase	Erase both block	Erase main memory block

Table 20. Flash Timing Parameters

Operating Conditions: $V_{SS} = V_{SSA} = 0\text{ V}$, $V_{DD} = V_{DDA} = 3.0\text{--}3.6\text{ V}$, $T_A = -40^\circ\text{ to }+85^\circ\text{C}$, $C_L \leq 50\text{ pF}$

Characteristic	Symbol	Min	Typ	Max	Unit	Figure
Program time	T_{prog}^*	20	–	–	us	Figure 6
Erase time	T_{erase}^*	20	–	–	ms	Figure 7
Mass erase time	T_{me}^*	100	–	–	ms	Figure 8
Endurance ¹	E_{CYC}	10,000	20,000	–	cycles	
Data Retention ¹ @ 5000 cycles	D_{RET}	10	30	–	years	

The following parameters should only be used in the Manual Word Programming Mode

PROG/ERASE to NVSTR set up time	T_{nvst}^*	–	5	–	us	Figure 6, Figure 7, Figure 8
NVSTR hold time	T_{nvh}^*	–	5	–	us	Figure 6, Figure 7
NVSTR hold time (mass erase)	T_{nvh1}^*	–	100	–	us	Figure 8
NVSTR to program set up time	T_{pgs}^*	–	10	–	us	Figure 6
Recovery time	T_{rcv}^*	–	1	–	us	Figure 6, Figure 7, Figure 8
Cumulative program HV period ²	T_{hv}	–	3	–	ms	Figure 6
Program hold time ³	T_{pgh}	–	–	–		Figure 6
Address/data set up time ³	T_{ads}	–	–	–		Figure 6
Address/data hold time ³	T_{adh}	–	–	–		Figure 6

1. One cycle is equal to an erase program and read.
2. T_{hv} is the cumulative high voltage programming time to the same row before next erase. The same address cannot be programmed twice before next erase.
3. Parameters are guaranteed by design in smart programming mode and must be one cycle or greater.

*The Flash interface unit provides registers for the control of these parameters.

www.datasheet4u.com

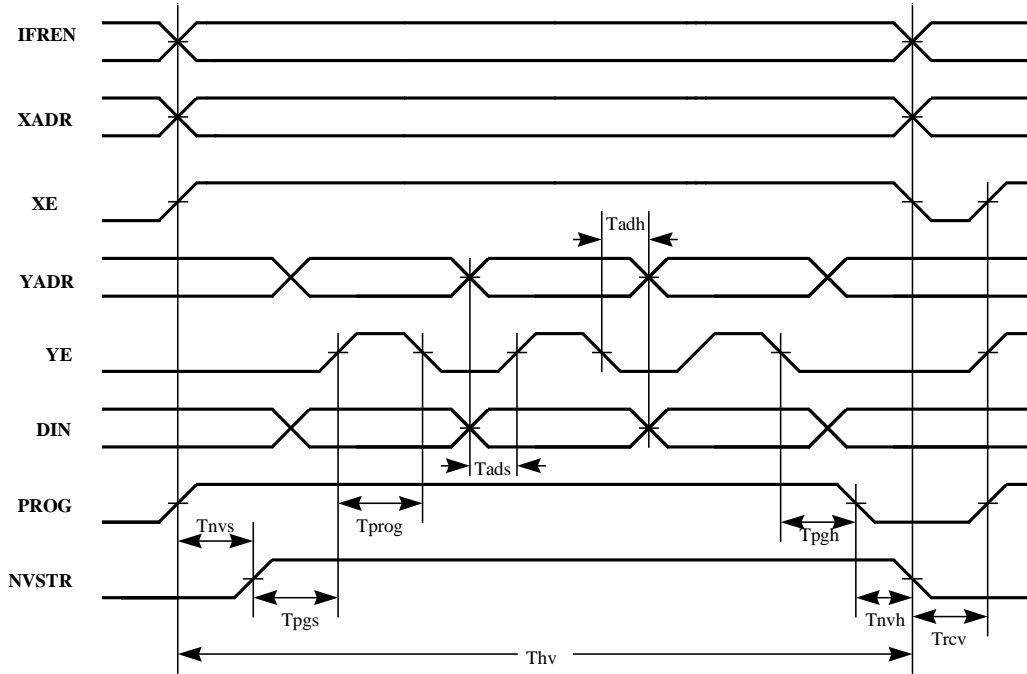

Figure 6. Flash Program Cycle

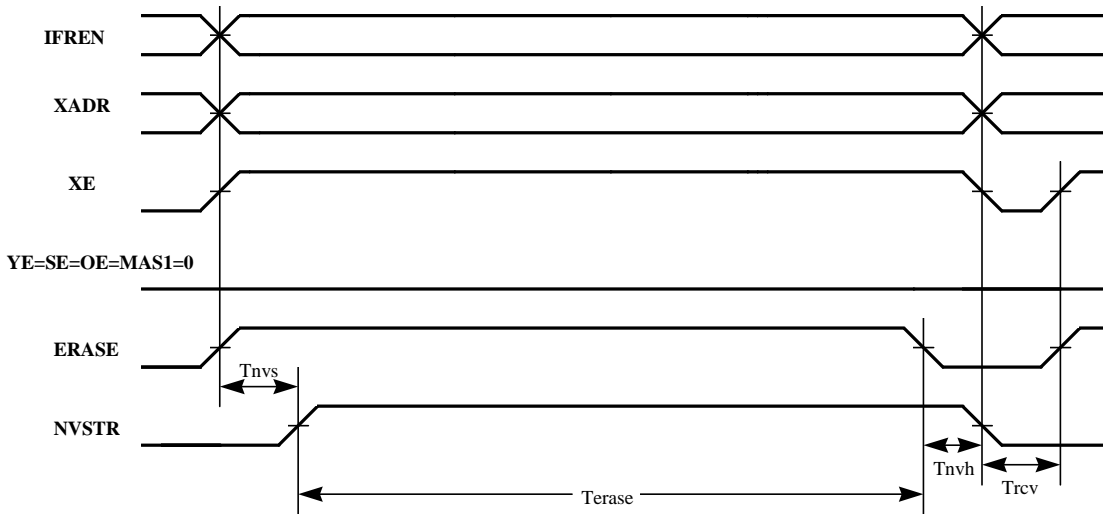

Figure 7. Flash Erase Cycle

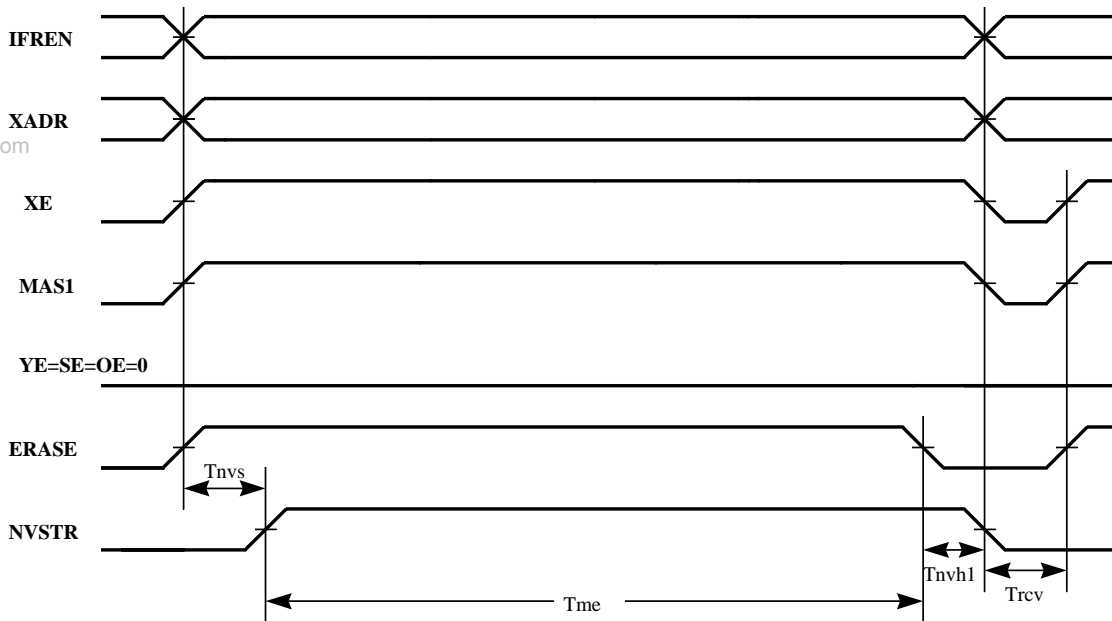

Figure 8. Flash Mass Erase Cycle

3.5 External Clock Operation

The 56F801 device clock is derived from either 1) an internal crystal oscillator circuit working in conjunction with an external crystal, 2) an external frequency source, or 3) an on-chip relaxation oscillator. To generate a reference frequency using the internal crystal oscillator circuit, a reference crystal external to the chip must be connected between the EXTAL and XTAL pins. Paragraphs 3.5.1 and 3.5.4 describe these methods of clocking. Whichever type of clock derivation is used provides a reference signal to a phase-locked loop (PLL) within the 56F801. In turn, the PLL generates a master reference frequency that determines the speed at which chip operations occur.

Application code can be set to change the frequency source between the relaxation oscillator and crystal oscillator or external source, and power down the relaxation oscillator if desired. Selection of which clock is used is determined by setting the PRECS bit in the PLLCR (phase-locked loop control register) word (bit 2). If the bit is set to 1, the external crystal oscillator circuit is selected. If the bit is set to 0, the internal relaxation oscillator is selected, and this is the default value of the bit when power is first applied.

3.5.1 Crystal Oscillator

The internal oscillator is also designed to interface with a parallel-resonant crystal resonator in the frequency range specified for the external crystal in Table 23. Figure 9 shows a recommended crystal oscillator circuit. Follow the crystal supplier's recommendations when selecting a crystal, since crystal parameters determine the component values required to provide maximum stability and reliable start-up. The crystal and associated components should be mounted as close as possible to the EXTAL and XTAL pins to minimize output distortion and start-up stabilization time. The internal 56F80x oscillator circuitry is designed to have no external load capacitors present. As shown in Figure 10 no external load capacitors should be used.

The 56F80x components internally are modeled as a parallel resonant oscillator circuit to provide a capacitive load on each of the oscillator pins (XTAL and EXTAL) of 10pF to 13pF over temperature and process variations. Using a typical value of internal capacitance on these pins of 12pF and a value of 3pF as a typical circuit board trace capacitance the parallel load capacitance presented to the crystal is 9pF as determined by the following equation:

www.datasheet4u.com

$$CL = \frac{CL1 * CL2}{CL1 + CL2} + Cs = \frac{12 * 12}{12 + 12} + 3 = 6 + 3 = 9pF$$

This is the value load capacitance that should be used when selecting a crystal and determining the actual frequency of operation of the crystal oscillator circuit.

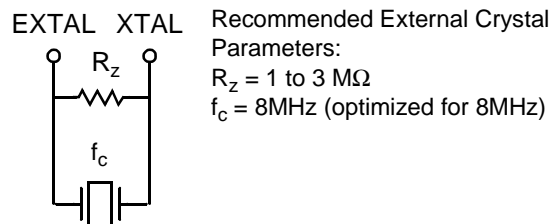

Figure 9. External Crystal Oscillator Circuit

3.5.2 Ceramic Resonator

It is also possible to drive the internal oscillator with a ceramic resonator, assuming the overall system design can tolerate the reduced signal integrity. In **Figure 10**, a typical ceramic resonator circuit is shown. Refer to supplier's recommendations when selecting a ceramic resonator and associated components. The resonator and components should be mounted as close as possible to the EXTAL and XTAL pins. The internal 56F80x oscillator circuitry is designed to have no external load capacitors present. As shown in **Figure 9** no external load capacitors should be used.

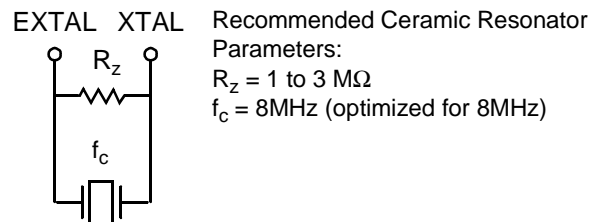

Figure 10. Connecting a Ceramic Resonator

Note: Motorola recommends only two terminal ceramic resonators vs. three terminal resonators (which contain an internal bypass capacitor to ground).

3.5.3 External Clock Source

The recommended method of connecting an external clock is given in **Figure 11**. The external clock source is connected to XTAL and the EXTAL pin is grounded.

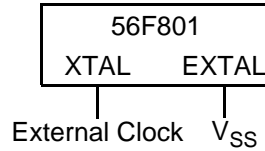

Figure 11. Connecting an External Clock Signal

www.datasheet4u.com

Table 21. External Clock Operation Timing Requirements³

Operating Conditions: $V_{SS} = V_{SSA} = 0\text{ V}$, $V_{DD} = V_{DDA} = 3.0\text{--}3.6\text{ V}$, $T_A = -40^\circ\text{ to }+85^\circ\text{C}$

Characteristic	Symbol	Min	Typ	Max	Unit
Frequency of operation (external clock driver) ¹	f_{osc}	0	—	80 ²	MHz
Clock Pulse Width ^{3, 4}	t_{PW}	6.25	—	—	ns

1. See Figure 11 for details on using the recommended connection of an external clock driver.
2. May not exceed 60MHz for the DSP56F801FA60 device.
3. The high or low pulse width must be no smaller than 6.25ns or the chip will not function.
4. Parameters listed are guaranteed by design.

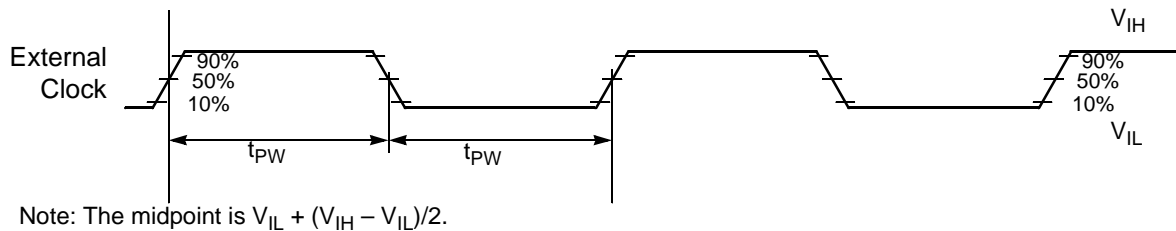

Figure 12. External Clock Timing

3.5.4 Use of On-Chip Relaxation Oscillator

An internal relaxation oscillator can supply the reference frequency when an external frequency source or crystal are not used. During a 56F801 boot or reset sequence, the relaxation oscillator is enabled by default, and the PRECS bit in the PLLCR word is set to 0 (Section 3.5). If an external oscillator is connected, the relaxation oscillator can be deselected instead by setting the PRECS bit in the PLLCR to 1. When this occurs, the PRECSS bit in the PLLSR (prescaler clock select status register) data word also sets to 1. If a changeover between internal and external oscillators is required at startup, internal device circuits compensate for any asynchronous transitions between the two clock signals so that no glitches occur in the resulting master clock to the chip. When changing clocks, the user must ensure that the clock source is not switched until the desired clock is enabled and stable.

To compensate for variances in the device manufacturing process, the accuracy of the relaxation oscillator can be incrementally adjusted to within $\pm 0.25\%$ of 8MHz by trimming an internal capacitor. Bits 0-7 of the IOSCTL (internal oscillator control) word allow the user to set in an additional offset (trim) to this preset value to increase or decrease capacitance. The default value of this trim is 128 units, making the power-up default capacitor size 432 units. Each unit added or deleted changes the output frequency by about 0.2%, allowing incremental adjustment until the desired frequency accuracy is achieved.

Table 22. Relaxation Oscillator Characteristics

Operating Conditions: $V_{SS} = V_{SSA} = 0\text{ V}$, $V_{DD} = V_{DDA} = 3.0\text{--}3.6\text{ V}$, $T_A = -40^\circ\text{ to }+85^\circ\text{C}$

Characteristic	Symbol	Min	Typ	Max	Unit
Frequency Accuracy ¹	Δf	—	± 2	± 5	%
Frequency Drift over Temp	$\Delta f/\Delta t$	—	± 0.1	—	%/°C
Frequency Drift over Supply	$\Delta f/\Delta V$	—	0.1	—	%/V
Trim Accuracy	Δf_T	—	± 0.25	—	%

1. Over full temperature range.

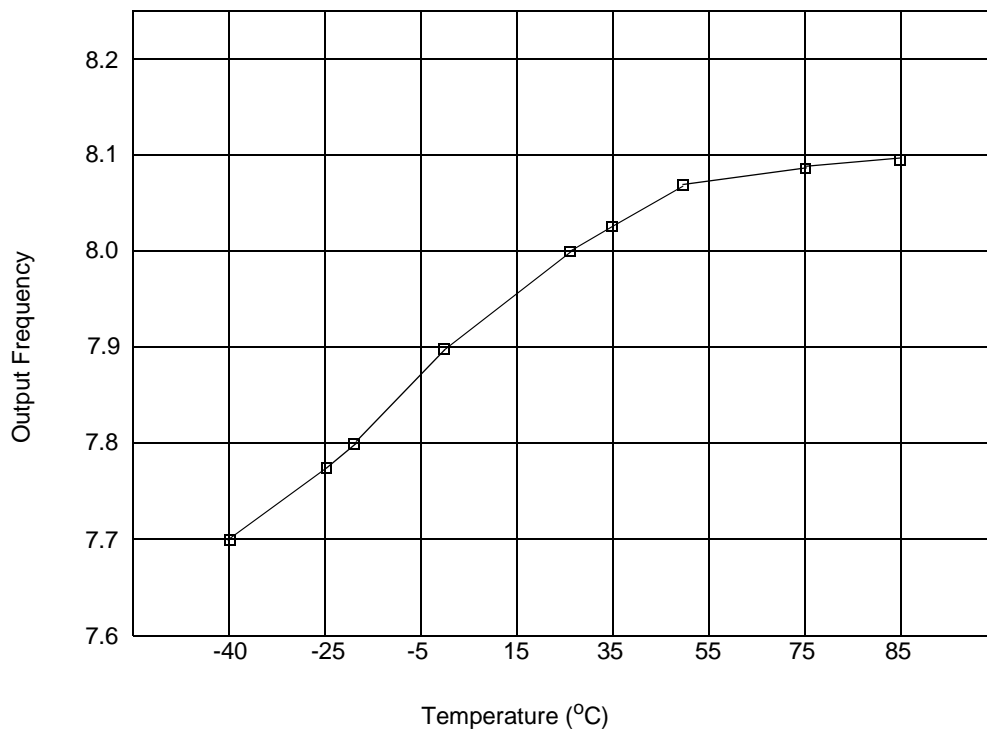

Figure 13. Typical Relaxation Oscillator Frequency vs. Temperature (Trimmed to 8MHz @ 25°C)

www.datasheet4u.com

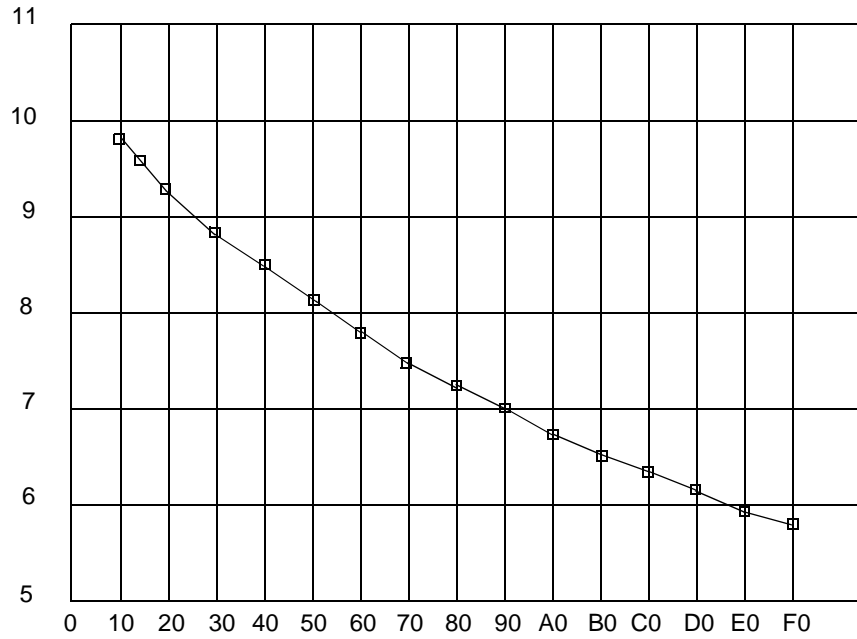

Figure 14. Typical Relaxation Oscillator Frequency vs. Trim Value @ 25°C

3.5.5 Phase Locked Loop Timing

Table 23. PLL Timing

Operating Conditions: $V_{SS} = V_{SSA} = 0$ V, $V_{DD} = V_{DDA} = 3.0$ – 3.6 V, $T_A = -40^\circ$ to $+85^\circ$ C

Characteristic	Symbol	Min	Typ	Max	Unit
External reference crystal frequency for the PLL ¹	f_{osc}	4	8	10	MHz
PLL output frequency ²	$f_{out}/2$	40	—	80 ³	MHz
PLL stabilization time ⁴ 0° to +85°C	t_{pils}	—	10	—	ms
PLL stabilization time ⁴ -40° to 0°C	t_{pils}	—	100	200	ms

1. An externally supplied reference clock should be as free as possible from any phase jitter for the PLL to work correctly. The PLL is optimized for 8MHz input crystal.
2. ZCLK may not exceed 80MHz. For additional information on ZCLK and $f_{out}/2$, please refer to the OCCS chapter in the User Manual. $ZCLK = f_{op}$
3. Will not exceed 60MHz for the DSP56F801FA60 device.
4. This is the minimum time required after the PLL setup is changed to ensure reliable operation.

3.6 Reset, Stop, Wait, Mode Select, and Interrupt Timing

Table 24. Reset, Stop, Wait, Mode Select, and Interrupt Timing^{1, 5}

Operating Conditions: $V_{SS} = V_{SSA} = 0\text{ V}$, $V_{DD} = V_{DDA} = 3.0\text{--}3.6\text{ V}$, $T_A = -40^\circ\text{ to }+85^\circ\text{C}$, $C_L \leq 50\text{pF}$

Characteristic	Symbol	Min	Max	Unit	See
$\overline{\text{RESET}}$ Assertion to Address, Data and Control Signals High Impedance	t_{RAZ}	—	21	ns	Figure 15
Minimum $\overline{\text{RESET}}$ Assertion Duration ² OMR Bit 6 = 0 OMR Bit 6 = 1	t_{RA}	275,000T 128T	— —	ns ns	Figure 15
$\overline{\text{RESET}}$ De-assertion to First External Address Output	t_{RDA}	33T	34T	ns	Figure 15
Edge-sensitive Interrupt Request Width	t_{IRW}	1.5T	—	ns	Figure 16
$\overline{\text{IRQA}}$, $\overline{\text{IRQB}}$ Assertion to External Data Memory Access Out Valid, caused by first instruction execution in the interrupt service routine	t_{IDM}	15T	—	ns	Figure 17
$\overline{\text{IRQA}}$, $\overline{\text{IRQB}}$ Assertion to General Purpose Output Valid, caused by first instruction execution in the interrupt service routine	t_{IG}	16T	—	ns	Figure 17
$\overline{\text{IRQA}}$ Low to First Valid Interrupt Vector Address Out recovery from Wait State ³	t_{IRI}	13T	—	ns	Figure 18
$\overline{\text{IRQA}}$ Width Assertion to Recover from Stop State ⁴	t_{IW}	2T	—	ns	Figure 19
Delay from $\overline{\text{IRQA}}$ Assertion to Fetch of first instruction (exiting Stop) OMR Bit 6 = 0 OMR Bit 6 = 1	t_{IF}	— —	275,000T 12T	ns ns	Figure 19
Duration for Level Sensitive $\overline{\text{IRQA}}$ Assertion to Cause the Fetch of First $\overline{\text{IRQA}}$ Interrupt Instruction (exiting Stop) OMR Bit 6 = 0 OMR Bit 6 = 1	t_{IRQ}	— —	275,000T 12T	ns ns	Figure 20
Delay from Level Sensitive $\overline{\text{IRQA}}$ Assertion to First Interrupt Vector Address Out Valid (exiting Stop) OMR Bit 6 = 0 OMR Bit 6 = 1	t_{II}	— —	275,000T 12T	ns ns	Figure 20

- In the formulas, T = clock cycle. For an operating frequency of 80MHz, T = 12.5ns.
- Circuit stabilization delay is required during reset when using an external clock or crystal oscillator in two cases:
 - After power-on reset
 - When recovering from Stop state
- The minimum is specified for the duration of an edge-sensitive $\overline{\text{IRQA}}$ interrupt required to recover from the Stop state. This is not the minimum required so that the $\overline{\text{IRQA}}$ interrupt is accepted.
- The interrupt instruction fetch is visible on the pins only in Mode 3.
- Parameters listed are guaranteed by design.

www.datasheet4u.com

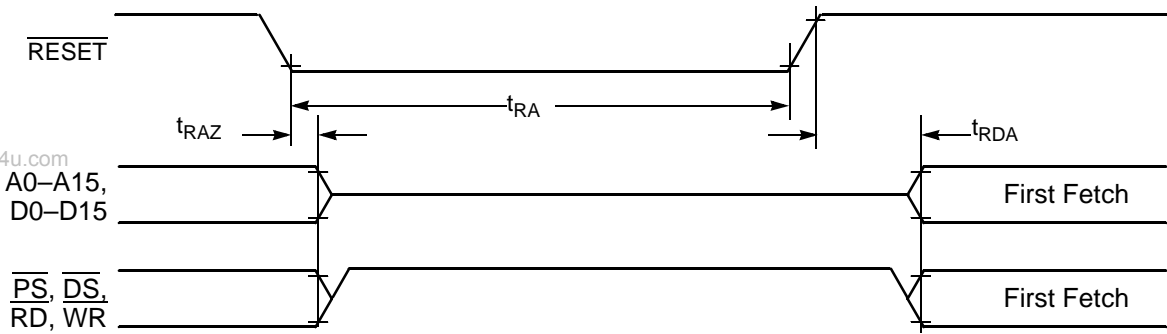

Figure 15. Asynchronous Reset Timing

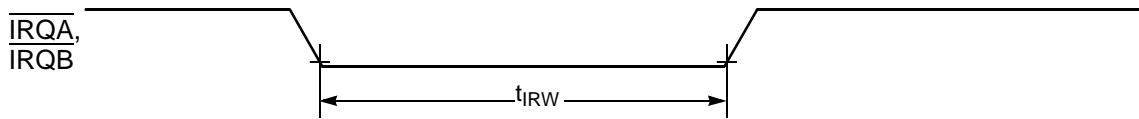

Figure 16. External Interrupt Timing (Negative-Edge-Sensitive)

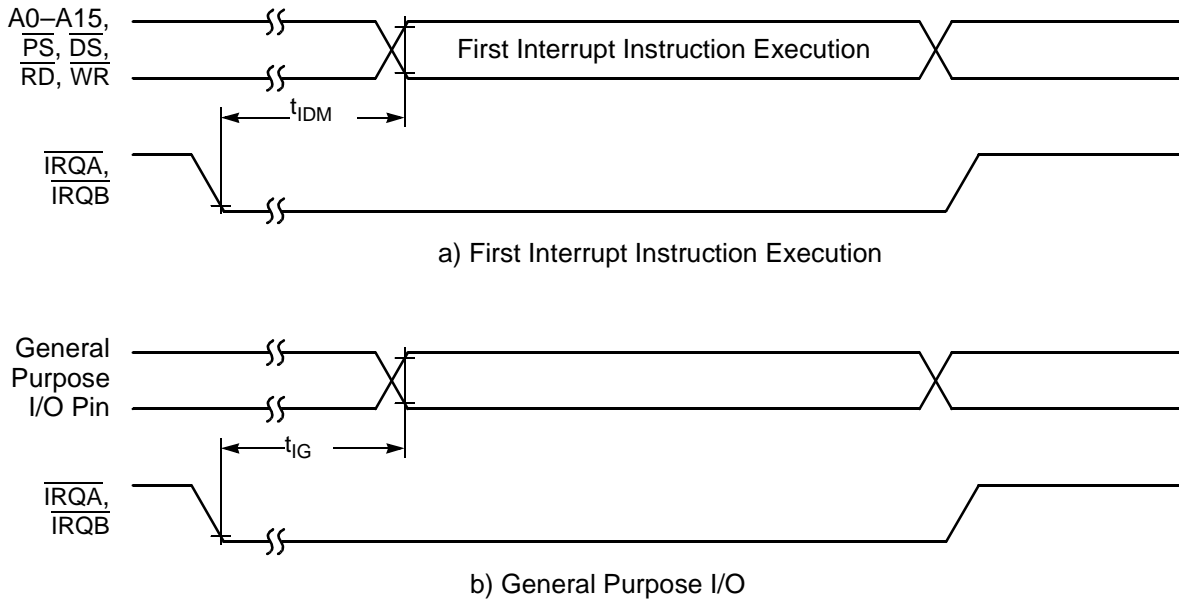

Figure 17. External Level-Sensitive Interrupt Timing

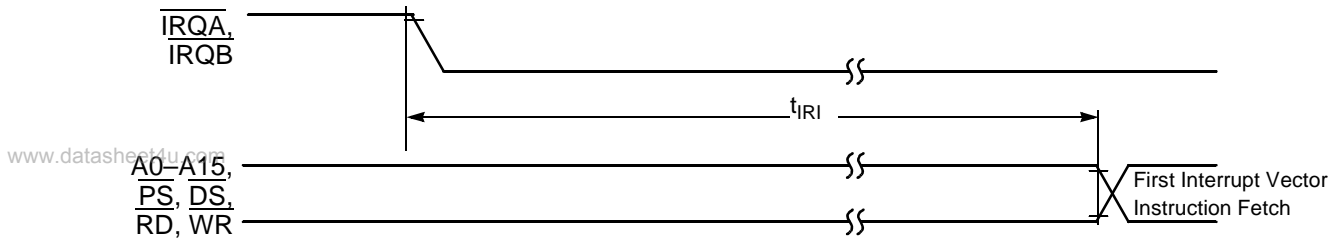

Figure 18. Interrupt from Wait State Timing

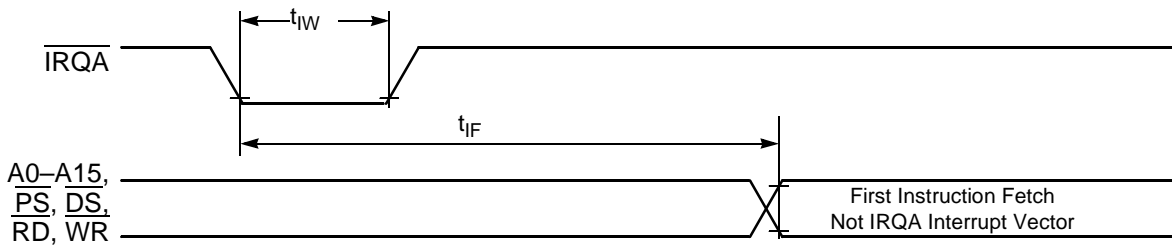

Figure 19. Recovery from Stop State Using Asynchronous Interrupt Timing

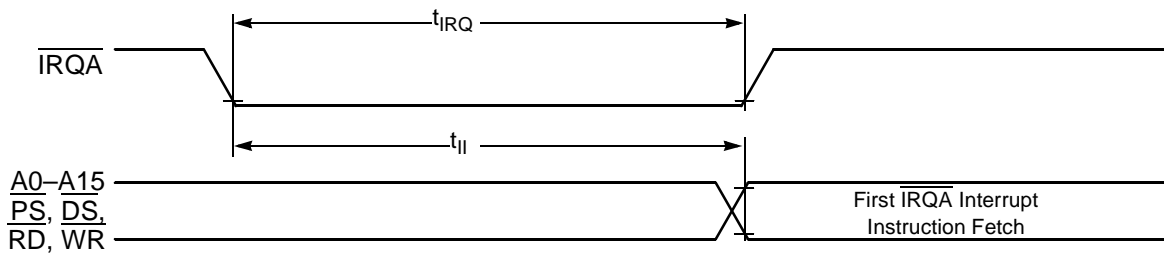

Figure 20. Recovery from Stop State Using $\overline{\text{IRQA}}$ Interrupt Service

3.7 Serial Peripheral Interface (SPI) Timing

Table 25. SPI Timing¹

Operating Conditions: $V_{SS} = V_{SSA} = 0\text{ V}$, $V_{DD} = V_{DDA} = 3.0\text{--}3.6\text{ V}$, $T_A = -40^\circ\text{ to }+85^\circ\text{C}$, $C_L \leq 50\text{pF}$

Characteristic	Symbol	Min	Max	Unit	See Figure
Cycle time Master Slave	t_C	50 25	— —	ns ns	Figures 21, 22, 23, 24
Enable lead time Master Slave	t_{ELD}	— 25	— —	ns ns	Figure 24
Enable lag time Master Slave	t_{ELG}	— 100	— —	ns ns	Figure 24
Clock (SCK) high time Master Slave	t_{CH}	17.6 12.5	— —	ns ns	Figures 21, 22, 23, 24
Clock (SCK) low time Master Slave	t_{CL}	24.1 25	— —	ns ns	Figures 21, 22, 23, 24
Data setup time required for inputs Master Slave	t_{DS}	20 0	— —	ns ns	Figures 21, 22, 23, 24
Data hold time required for inputs Master Slave	t_{DH}	0 2	— —	ns ns	Figures 21, 22, 23, 24
Access time (time to data active from high-impedance state) Slave	t_A	4.8	15	ns	Figure 24
Disable time (hold time to high-impedance state) Slave	t_D	3.7	15.2	ns	Figure 24
Data Valid for outputs Master Slave (after enable edge)	t_{DV}	— —	4.5 20.4	ns ns	Figures 21, 22, 23, 24
Data invalid Master Slave	t_{DI}	0 0	— —	ns ns	Figures 21, 22, 23, 24
Rise time Master Slave	t_R	— —	11.5 10.0	ns ns	Figures 21, 22, 23, 24
Fall time Master Slave	t_F	— —	9.7 9.0	ns ns	Figures 21, 22, 23, 24

1. Parameters listed are guaranteed by design.

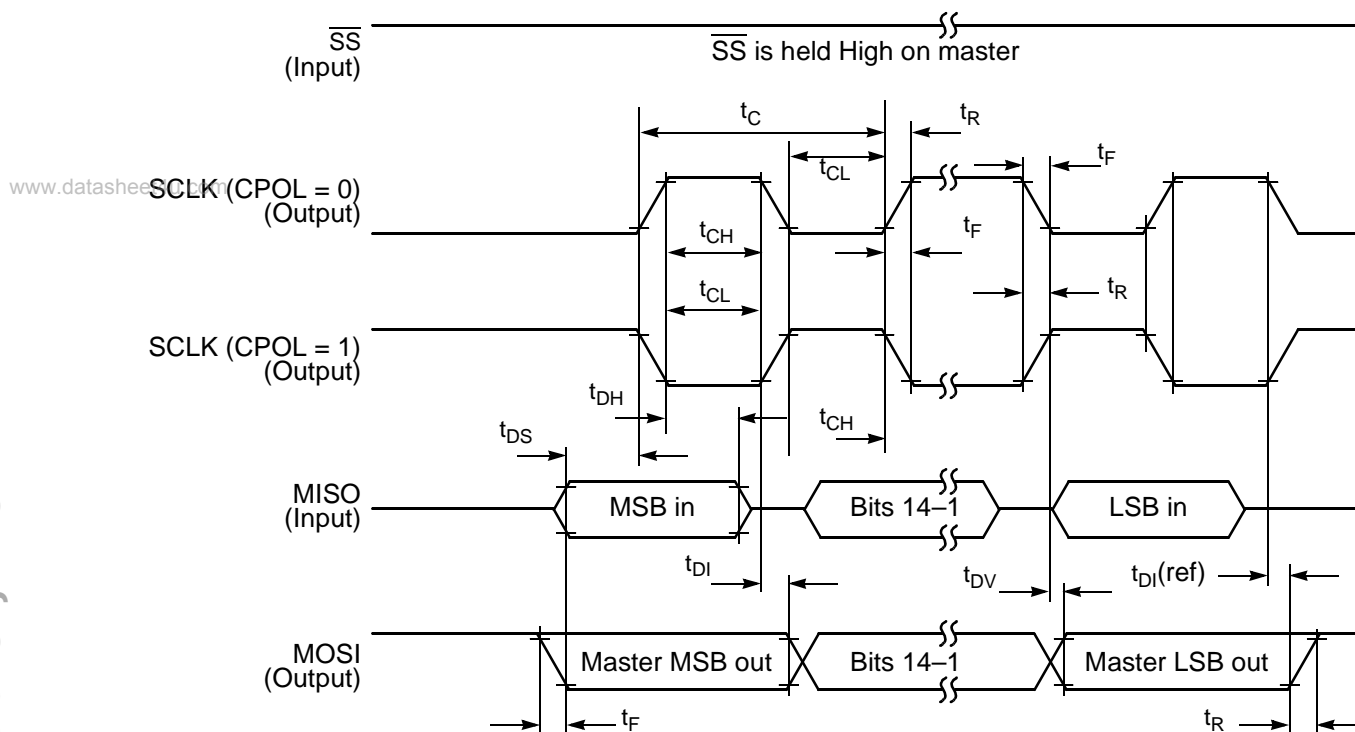

Figure 21. SPI Master Timing (CPHA = 0)

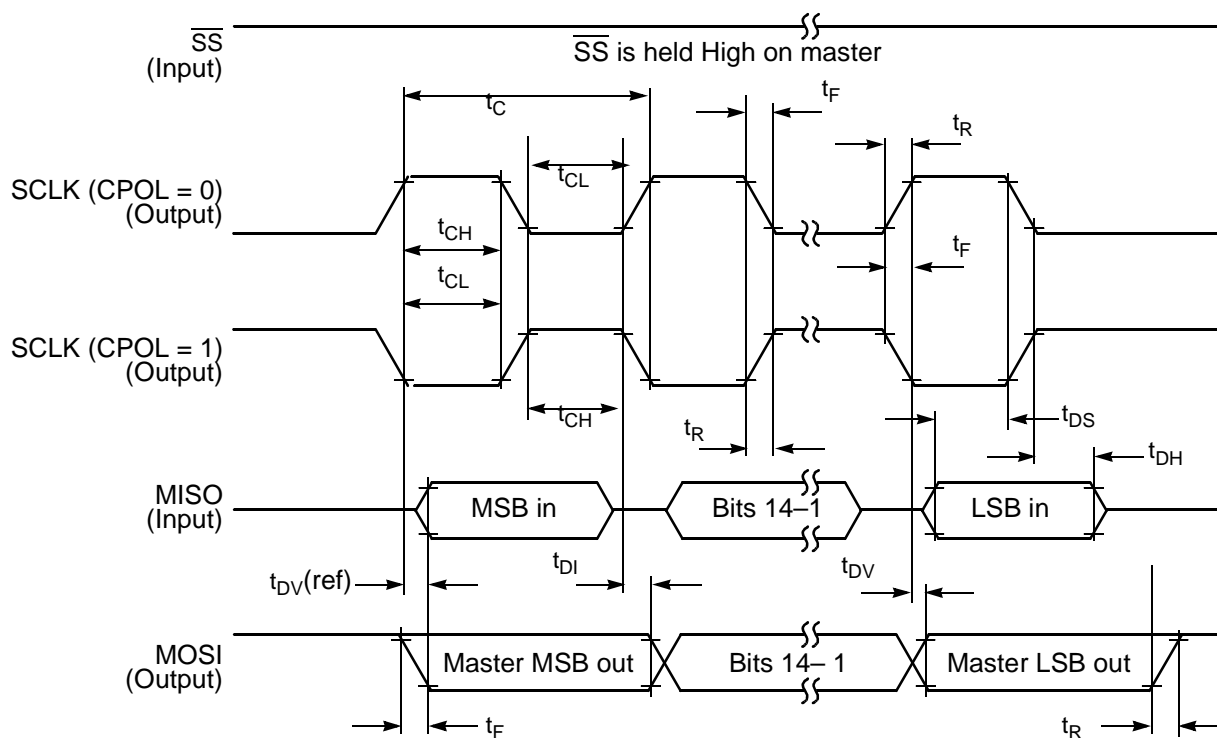

Figure 22. SPI Master Timing (CPHA = 1)

www.datasheet4u.com

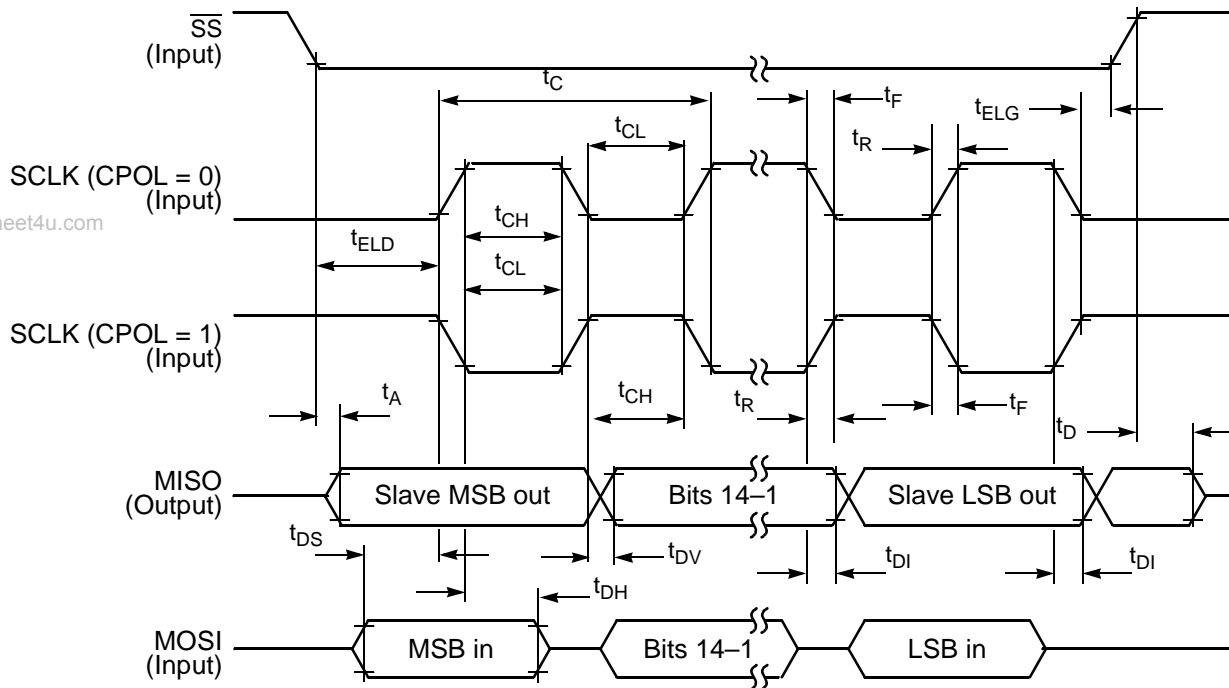

Figure 23. SPI Slave Timing (CPHA = 0)

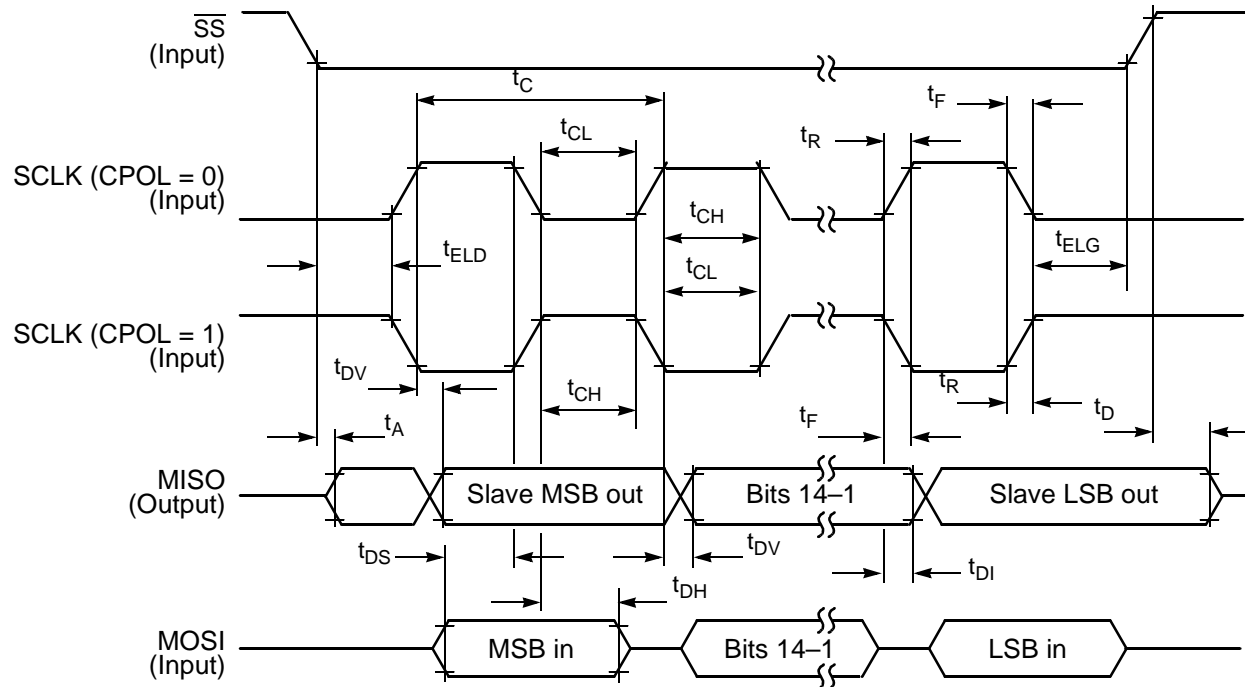

Figure 24. SPI Slave Timing (CPHA = 1)

3.8 Quad Timer Timing

Table 26. Timer Timing^{1, 2}

Operating Conditions: $V_{SS} = V_{SSA} = 0\text{ V}$, $V_{DD} = V_{DDA} = 3.0\text{--}3.6\text{ V}$, $T_A = -40^\circ\text{ to }+85^\circ\text{C}$, $C_L \leq 50\text{pF}$

Characteristic	Symbol	Min	Max	Unit
Timer input period	P_{IN}	$4T+6$	—	ns
Timer input high/low period	P_{INHL}	$2T+3$	—	ns
Timer output period	P_{OUT}	$2T$	—	ns
Timer output high/low period	P_{OUTHL}	$1T$	—	ns

1. In the formulas listed, T = clock cycle. For 80MHz operation, T = 12.5ns.
2. Parameters listed are guaranteed by design.

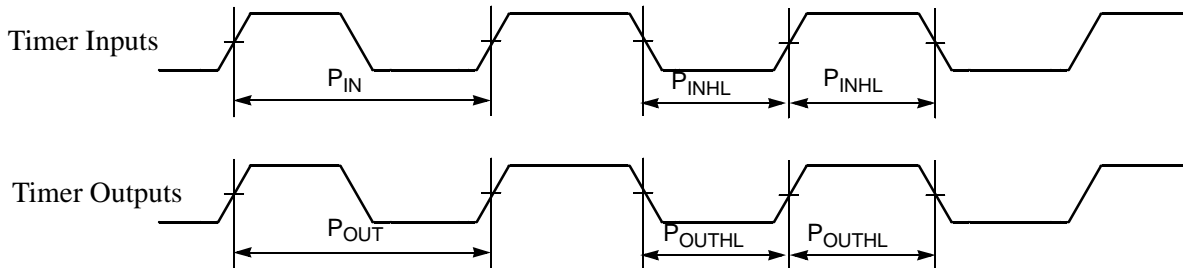

Figure 25. Timer Timing

3.9 Serial Communication Interface (SCI) Timing

Table 27. SCI Timing⁴

Operating Conditions: $V_{SS} = V_{SSA} = 0\text{ V}$, $V_{DD} = V_{DDA} = 3.0\text{--}3.6\text{ V}$, $T_A = -40^\circ\text{ to }+85^\circ\text{C}$, $C_L \leq 50\text{pF}$

Characteristic	Symbol	Min	Max	Unit
Baud Rate ¹	BR	—	$(f_{MAX} * 2.5) / (80)$	Mbps
RXD ² Pulse Width	RXD_{PW}	$0.965/BR$	$1.04/BR$	ns
TXD ³ Pulse Width	TXD_{PW}	$0.965/BR$	$1.04/BR$	ns

1. f_{MAX} is the frequency of operation of the system clock in MHz.
2. The RXD pin in SCI0 is named RXD0 and the RXD pin in SCI1 is named RXD1.
3. The TXD pin in SCI0 is named TXD0 and the TXD pin in SCI1 is named TXD1.
4. Parameters listed are guaranteed by design.

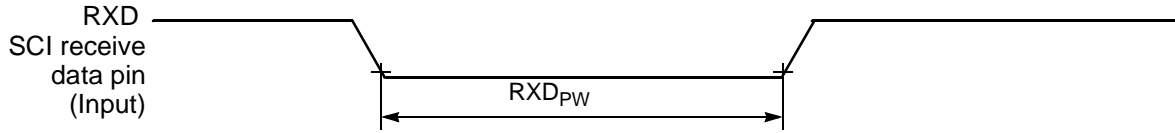

www.datasheet4u.com

Figure 26. RXD Pulse Width

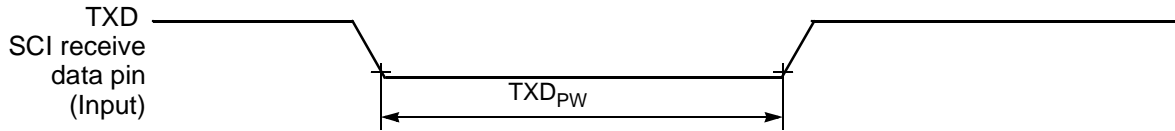

Figure 27. TXD Pulse Width

3.10 Analog-to-Digital Converter (ADC) Characteristics

Table 28. ADC Characteristics

Operating Conditions: $V_{SS} = V_{SSA} = 0\text{ V}$, $V_{DD} = V_{DDA} = 3.0\text{--}3.6\text{ V}$, $V_{REF} = V_{DD} - 0.3\text{V}$, ADCDIV = 4, 9, or 14 (for optimal performance), ADC clock = 4MHz, 3.0–3.6 V, $T_A = -40^\circ\text{ to }+85^\circ\text{C}$, $C_L \leq 50\text{pF}$

Characteristic	Symbol	Min	Typ	Max	Unit
ADC input voltages	V_{ADCIN}	0 ¹	—	V_{REF} ²	V
Resolution	R_{ES}	12	—	12	Bits
Integral Non-Linearity ³	INL	—	+/- 4	+/- 5	LSB ⁴
Differential Non-Linearity	DNL	—	+/- 0.9	+/- 1	LSB ⁴
Monotonicity	GUARANTEED				
ADC internal clock ⁵	f_{ADC}	0.5	—	5	MHz
Conversion range	R_{AD}	V_{SSA}	—	V_{DDA}	V
Conversion time	t_{ADC}	—	6	—	t_{AIC} cycles ⁶
Sample time	t_{ADS}	—	1	—	t_{AIC} cycles ⁶
Input capacitance	C_{ADI}	—	5	—	pF ⁶
Gain Error (transfer gain) ⁵	E_{GAIN}	1.00	1.10	1.15	—
Offset Voltage ⁵	V_{OFFSET}	+10	+230	+325	mV
Total Harmonic Distortion ⁵	THD	55	60	—	dB
Signal-to-Noise plus Distortion ⁵	SINAD	54	56	—	dB
Effective Number of Bits ⁵	ENOB	8.5	9.5	—	bit

Table 28. ADC Characteristics (Continued)

Operating Conditions: $V_{SS} = V_{SSA} = 0\text{ V}$, $V_{DD} = V_{DDA} = 3.0\text{--}3.6\text{ V}$, $V_{REF} = V_{DD} - 0.3\text{V}$, $ADCDIV = 4, 9, \text{ or } 14$ (for optimal performance), ADC clock = 4MHz, 3.0–3.6 V, $T_A = -40^\circ \text{ to } +85^\circ\text{C}$, $C_L \leq 50\text{pF}$

Characteristic	Symbol	Min	Typ	Max	Unit
Spurious Free Dynamic Range ⁵	SFDR	60	65	—	dB
Bandwidth	BW	—	100	—	KHz
ADC Quiescent Current (both ADCs)	I_{ADC}	—	50	—	mA
V_{REF} Quiescent Current (both ADCs)	I_{VREF}	—	12	16.5	mA

- For optimum ADC performance, keep the minimum V_{ADCIN} value $\geq 250\text{mV}$. Inputs less than 250mV volts may convert to a digital output code of 0 or cause erroneous conversions.
- V_{REF} must be equal to or less than V_{DDA} and must be greater than 2.7V. For optimal ADC performance, set V_{REF} to $V_{DDA} - 0.3\text{V}$.
- Measured in 10-90% range.
- LSB = Least Significant Bit.
- Guaranteed by characterization.
- $t_{AIC} = 1/f_{ADIC}$

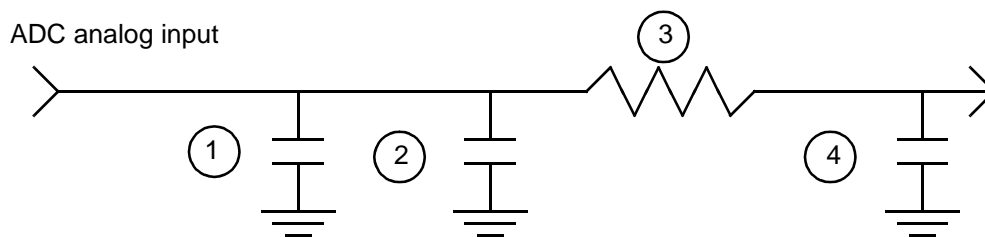

Figure 28. Equivalent Analog Input Circuit

- Parasitic capacitance due to package, pin to pin, and pin to package base coupling. (1.8pf)
- Parasitic capacitance due to the chip bond pad, ESD protection devices and signal routing. (2.04pf)
- Equivalent resistance for the ESD isolation resistor and the channel select mux. (500 ohms)
- Sampling capacitor at the sample and hold circuit. Capacitor 4 is normally disconnected from the input and is only connected to it at sampling time. (1pf)

3.11 JTAG Timing

Table 29. JTAG Timing ^{1, 3}

Operating Conditions: $V_{SS} = V_{SSA} = 0\text{ V}$, $V_{DD} = V_{DDA} = 3.0\text{--}3.6\text{ V}$, $T_A = -40^\circ\text{ to }+85^\circ\text{C}$, $C_L \leq 50\text{pF}$

Characteristic	Symbol	Min	Max	Unit
TCK frequency of operation ²	f_{OP}	DC	10	MHz
TCK cycle time	t_{CY}	100	—	ns
TCK clock pulse width	t_{PW}	50	—	ns
TMS, TDI data setup time	t_{DS}	0.4	—	ns
TMS, TDI data hold time	t_{DH}	1.2	—	ns
TCK low to TDO data valid	t_{DV}	—	26.6	ns
TCK low to TDO tri-state	t_{TS}	—	23.5	ns
$\overline{\text{TRST}}$ assertion time	t_{TRST}	50	—	ns
$\overline{\text{DE}}$ assertion time	t_{DE}	8T	—	ns

1. Timing is both wait state and frequency dependent. For the values listed, T = clock cycle. For 80MHz operation, T = 12.5ns.
2. TCK frequency of operation must be less than 1/8 the processor rate.
3. Parameters listed are guaranteed by design.

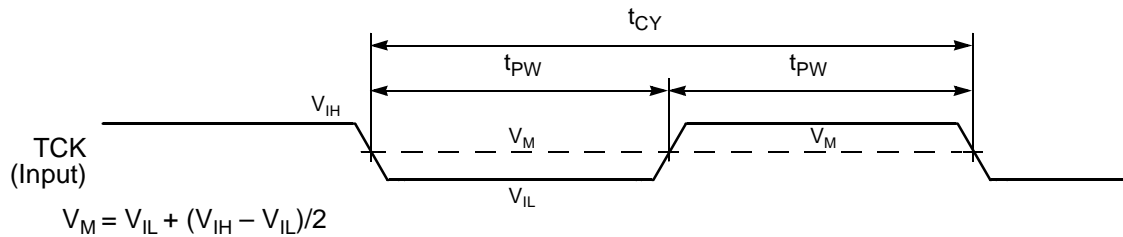

Figure 29. Test Clock Input Timing Diagram

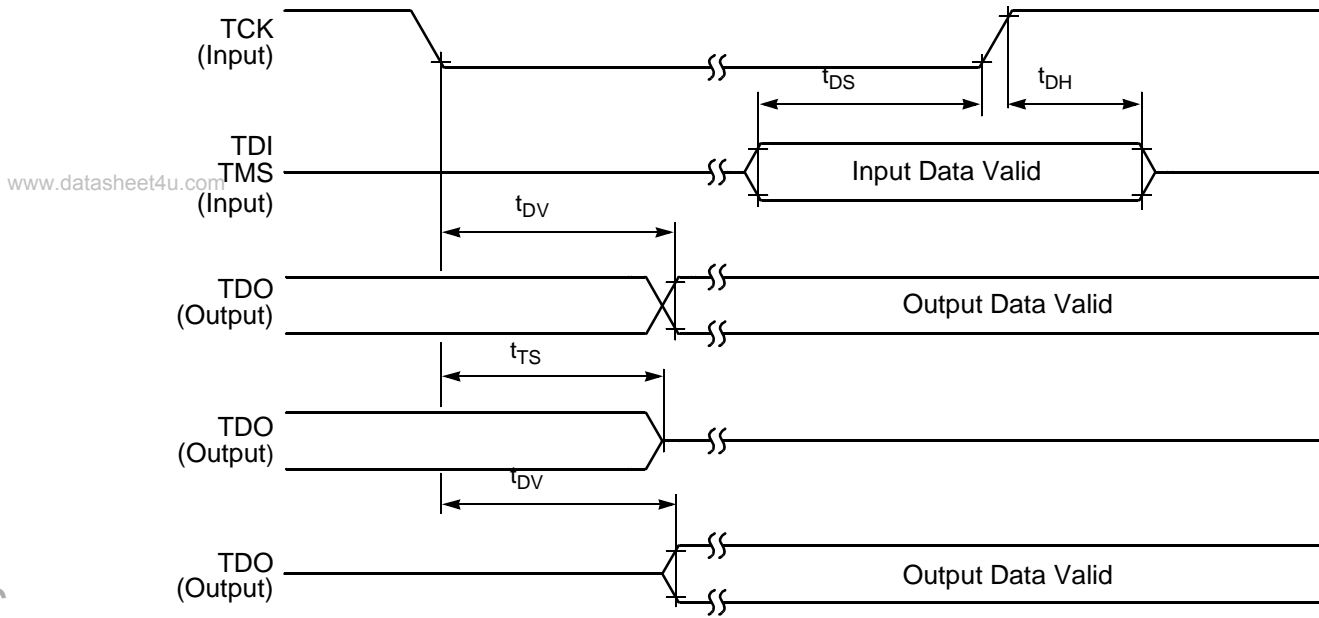

Figure 30. Test Access Port Timing Diagram



Figure 31. TRST Timing Diagram



Figure 32. OnCE—Debug Event

Part 4 Packaging

4.1 Package and Pin-Out Information 56F801

This section contains package and pin-out information for the 48-pin LQFP configuration of the 56F801.

www.datasheet4u.com

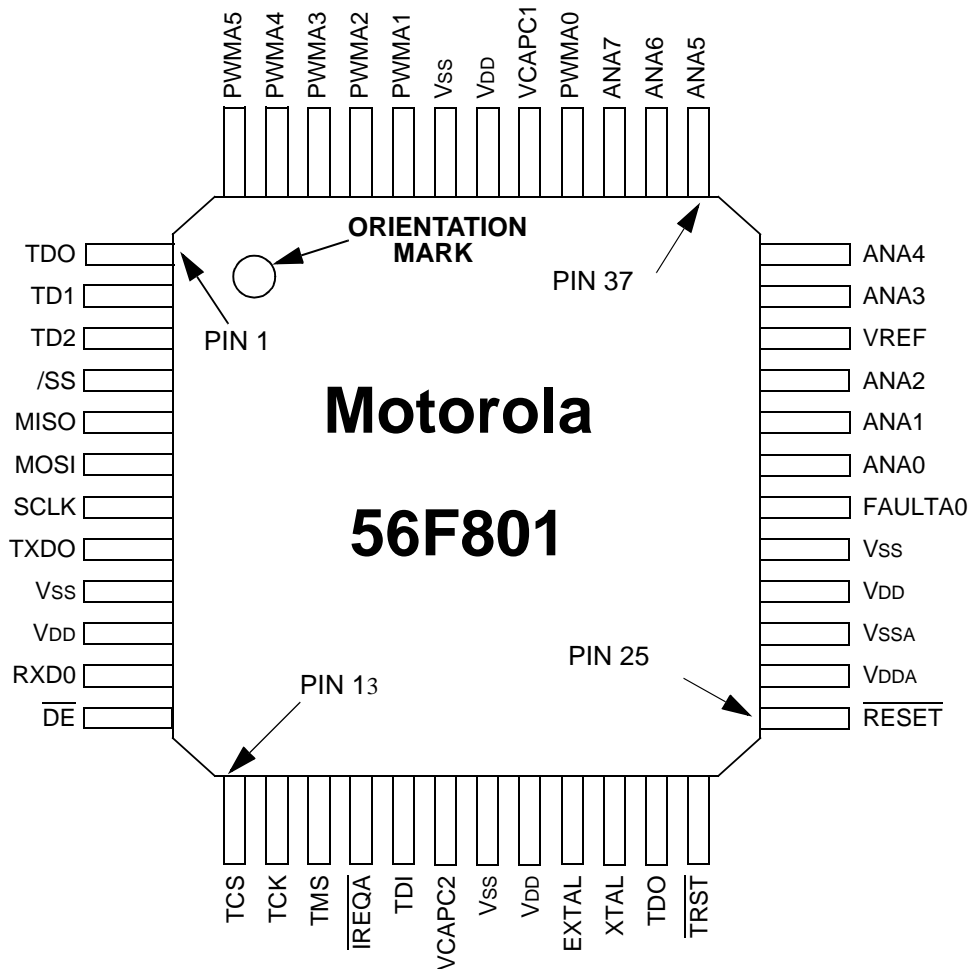

Figure 33. Top View, 56F801 48-pin LQFP Package

Table 30. 56F801 Pin Identification by Pin Number

Pin No.	Signal Name	Pin No.	Signal Name	Pin No.	Signal Name	Pin No.	Signal Name
1	TD0	13	TCS	25	$\overline{\text{RESET}}$	37	ANA5
2	TD1	14	TCK	26	V_{DDA}	38	ANA6
3	TD2	15	TMS	27	V_{SSA}	39	ANA7
4	$\overline{\text{SS}}$	16	$\overline{\text{IREQA}}$	28	V_{DD}	40	PWMA0
5	MISO	17	TDI	29	V_{SS}	41	VCAPC1
6	MOSI	18	VCAPC2	30	FAULTA0	42	V_{DD}
7	SCLK	19	V_{SS}	31	ANA0	43	V_{SS}
8	TXD0	20	V_{DD}	32	ANA1	44	PWMA1
9	V_{SS}	21	EXTAL	33	ANA2	45	PWMA2
10	V_{DD}	22	XTAL	34	VREF	46	PWMA3
11	RXD0	23	TDO	35	ANA3	47	PWMA4
12	$\overline{\text{DE}}$	24	$\overline{\text{TRST}}$	36	ANA4	48	PWMA5

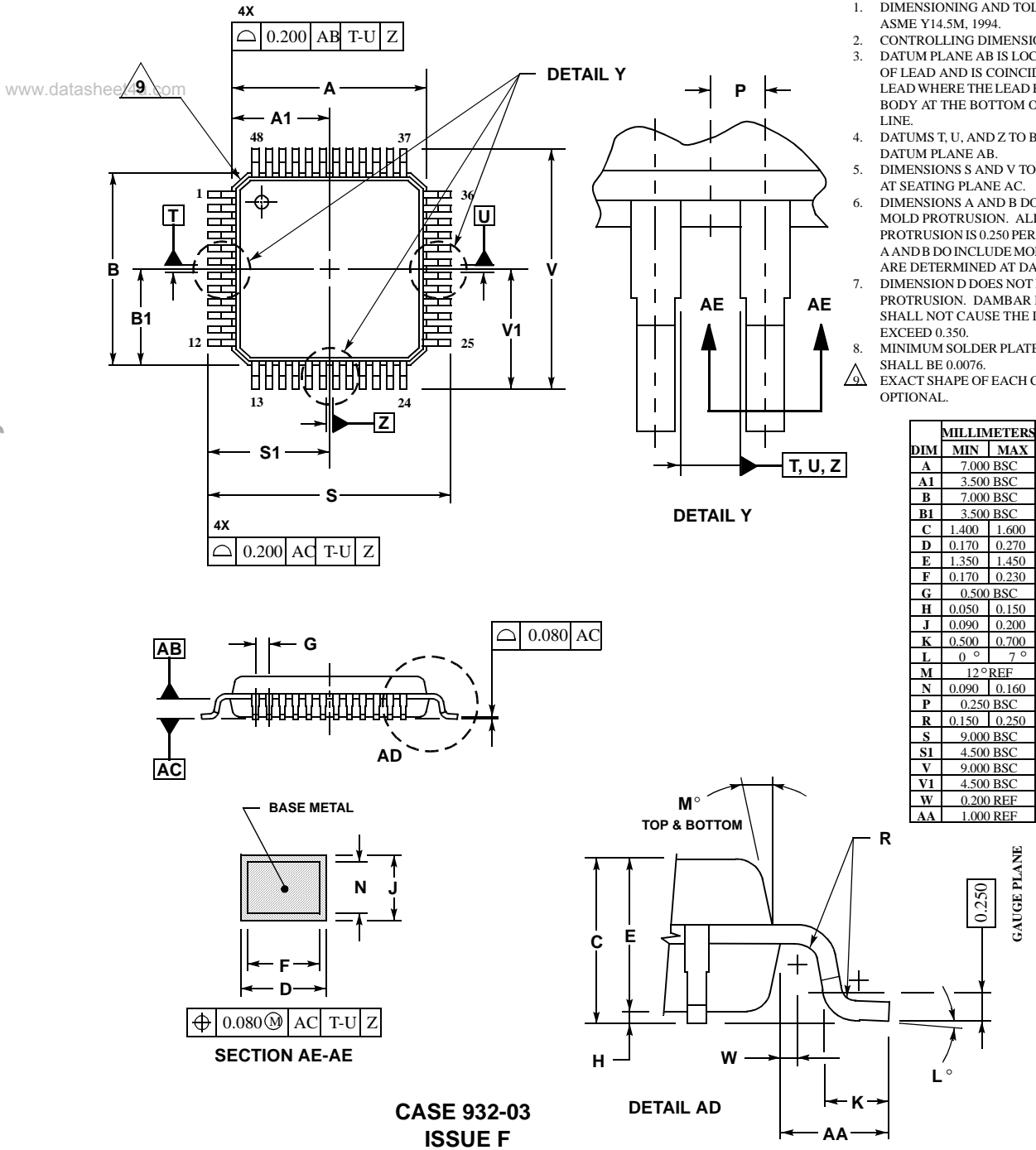

Figure 34. 48-pin LQFP Mechanical Information

Part 5 Design Considerations

5.1 Thermal Design Considerations

An estimation of the chip junction temperature, T_J , in °C can be obtained from the equation:

www.datasheet4u.com

$$\text{Equation 1: } T_J = T_A + (P_D \times R_{\theta JA})$$

Where:

T_A = ambient temperature °C

$R_{\theta JA}$ = package junction-to-ambient thermal resistance °C/W

P_D = power dissipation in package

Historically, thermal resistance has been expressed as the sum of a junction-to-case thermal resistance and a case-to-ambient thermal resistance:

$$\text{Equation 2: } R_{\theta JA} = R_{\theta JC} + R_{\theta CA}$$

Where:

$R_{\theta JA}$ = package junction-to-ambient thermal resistance °C/W

$R_{\theta JC}$ = package junction-to-case thermal resistance °C/W

$R_{\theta CA}$ = package case-to-ambient thermal resistance °C/W

$R_{\theta JC}$ is device-related and cannot be influenced by the user. The user controls the thermal environment to change the case-to-ambient thermal resistance, $R_{\theta CA}$. For example, the user can change the air flow around the device, add a heat sink, change the mounting arrangement on the Printed Circuit Board (PCB), or otherwise change the thermal dissipation capability of the area surrounding the device on the PCB. This model is most useful for ceramic packages with heat sinks; some 90% of the heat flow is dissipated through the case to the heat sink and out to the ambient environment. For ceramic packages, in situations where the heat flow is split between a path to the case and an alternate path through the PCB, analysis of the device thermal performance may need the additional modeling capability of a system level thermal simulation tool.

The thermal performance of plastic packages is more dependent on the temperature of the PCB to which the package is mounted. Again, if the estimations obtained from $R_{\theta JA}$ do not satisfactorily answer whether the thermal performance is adequate, a system level model may be appropriate.

Definitions:

A complicating factor is the existence of three common definitions for determining the junction-to-case thermal resistance in plastic packages:

- Measure the thermal resistance from the junction to the outside surface of the package (case) closest to the chip mounting area when that surface has a proper heat sink. This is done to minimize temperature variation across the surface.
- Measure the thermal resistance from the junction to where the leads are attached to the case. This definition is approximately equal to a junction to board thermal resistance.
- Use the value obtained by the equation $(T_J - T_T)/P_D$ where T_T is the temperature of the package case determined by a thermocouple.

The thermal characterization parameter is measured per JESD51-2 specification using a 40-gauge type T thermocouple epoxied to the top center of the package case. The thermocouple should be positioned so that the thermocouple junction rests on the package. A small amount of epoxy is placed over the thermocouple junction and over about 1mm of wire extending from the junction. The thermocouple wire is placed flat against the package case to avoid measurement errors caused by cooling effects of the thermocouple wire.

When heat sink is used, the junction temperature is determined from a thermocouple inserted at the interface between the case of the package and the interface material. A clearance slot or hole is normally required in the heat sink. Minimizing the size of the clearance is important to minimize the change in thermal performance caused by removing part of the thermal interface to the heat sink. Because of the experimental difficulties with this technique, many engineers measure the heat sink temperature and then back-calculate the case temperature using a separate measurement of the thermal resistance of the interface. From this case temperature, the junction temperature is determined from the junction-to-case thermal resistance.

5.2 Electrical Design Considerations

CAUTION

This device contains protective circuitry to guard against damage due to high static voltage or electrical fields. However, normal precautions are advised to avoid application of any voltages higher than maximum rated voltages to this high-impedance circuit. Reliability of operation is enhanced if unused inputs are tied to an appropriate voltage level.

Use the following list of considerations to assure correct operation:

- Provide a low-impedance path from the board power supply to each V_{DD} pin on the hybrid controller, and from the board ground to each V_{SS} (GND) pin.
- The minimum bypass requirement is to place 0.1 μF capacitors positioned as close as possible to the package supply pins. The recommended bypass configuration is to place one bypass capacitor on each of the ten V_{DD}/V_{SS} pairs, including V_{DDA}/V_{SSA} . Ceramic and tantalum capacitors tend to provide better performance tolerances.
- Ensure that capacitor leads and associated printed circuit traces that connect to the chip V_{DD} and V_{SS} (GND) pins are less than 0.5 inch per capacitor lead.
- Bypass the V_{DD} and V_{SS} layers of the PCB with approximately 100 μF , preferably with a high-grade capacitor such as a tantalum capacitor.
- Because the controller's output signals have fast rise and fall times, PCB trace lengths should be minimal.
- Consider all device loads as well as parasitic capacitance due to PCB traces when calculating capacitance. This is especially critical in systems with higher capacitive loads that could create higher transient currents in the V_{DD} and GND circuits.
- Take special care to minimize noise levels on the V_{REF} , V_{DDA} and V_{SSA} pins.

- Designs that utilize the $\overline{\text{TRST}}$ pin for JTAG port or OnCE module functionality (such as development or debugging systems) should allow a means to assert $\overline{\text{TRST}}$ whenever $\overline{\text{RESET}}$ is asserted, as well as a means to assert $\overline{\text{TRST}}$ independently of $\overline{\text{RESET}}$. $\overline{\text{TRST}}$ must be asserted at power up for proper operation. Designs that do not require debugging functionality, such as consumer products, $\overline{\text{TRST}}$ should be tied low.

www.datasheet4u.com • Because the Flash memory is programmed through the JTAG/OnCE port, designers should provide an interface to this port to allow in-circuit Flash programming.

Part 6 Ordering Information

Table 31 lists the pertinent information needed to place an order. Consult a Motorola Semiconductor sales office or authorized distributor to determine availability and to order parts.

Table 31. DSP56F801 Ordering Information

www.datasheet4u.com

Part	Supply Voltage	Package Type	Pin Count	Frequency (MHz)	Order Number
56F801	3.0–3.6 V	Low Profile Plastic Quad Flat Pack (LQFP)	48	80	DSP56F801FA80
56F801	3.0–3.6 V	Low Profile Plastic Quad Flat Pack (LQFP)	48	60	DSP56F801FA60

www.datasheet4u.com

Freescale Semiconductor, Inc.

HOW TO REACH US:

USA/EUROPE/LOCATIONS NOT LISTED:

Motorola Literature Distribution
P.O. Box 5405, Denver, Colorado 80217
www.data-sheet.com or 800-521-6274 or 480-768-2130

JAPAN:

Motorola Japan Ltd.
SPS, Technical Information Center
3-20-1, Minami-Azabu
Minato-ku
Tokyo 106-8573, Japan
81-3-3440-3569

ASIA/PACIFIC:

Motorola Semiconductors H.K. Ltd.
Silicon Harbour Centre
2 Dai King Street
Tai Po Industrial Estate
Tai Po, N.T. Hong Kong
852-26668334

HOME PAGE:

<http://motorola.com/semiconductors>

Information in this document is provided solely to enable system and software implementers to use Motorola products. There are no express or implied copyright licenses granted hereunder to design or fabricate any integrated circuits or integrated circuits based on the information in this document.

Motorola reserves the right to make changes without further notice to any products herein. Motorola makes no warranty, representation or guarantee regarding the suitability of its products for any particular purpose, nor does Motorola assume any liability arising out of the application or use of any product or circuit, and specifically disclaims any and all liability, including without limitation consequential or incidental damages. "Typical" parameters which may be provided in Motorola data sheets and/or specifications can and do vary in different applications and actual performance may vary over time. All operating parameters, including "Typicals" must be validated for each customer application by customer's technical experts. Motorola does not convey any license under its patent rights nor the rights of others. Motorola products are not designed, intended, or authorized for use as components in systems intended for surgical implant into the body, or other applications intended to support or sustain life, or for any other application in which the failure of the Motorola product could create a situation where personal injury or death may occur. Should Buyer purchase or use Motorola products for any such unintended or unauthorized application, Buyer shall indemnify and hold Motorola and its officers, employees, subsidiaries, affiliates, and distributors harmless against all claims, costs, damages, and expenses, and reasonable attorney fees arising out of, directly or indirectly, any claim of personal injury or death associated with such unintended or unauthorized use, even if such claim alleges that Motorola was negligent regarding the design or manufacture of the part.



Motorola and the Stylized M Logo are registered in the U.S. Patent and Trademark Office. digital dna is a trademark of Motorola, Inc. All other product or service names are the property of their respective owners. Motorola, Inc. is an Equal Opportunity/Affirmative Action Employer.

© Motorola, Inc. 2004