



FAN400A — Low-Power Green-Mode PWM Flyback Power Controller without Secondary Feedback

Features

- Linearly Decreasing PWM Frequency
- Green Mode Under Light-Load and Zero-Load Conditions
- Constant Voltage (CV) and Constant Current (CC)
- No Secondary Feedback
- Low Startup Current: 8μA
- Low Operating Current: 3.6mA
- Leading-Edge Blanking
- Constant Power Limit
- Universal AC Input Range
- Synchronized Slope Compensation
- 140°C OTP Sensor with Hysteresis
- V_{DD} Over-Voltage Clamping
- Cycle-by-Cycle Current Limiting
- Under-Voltage Lockout (UVLO)
- Fixed PWM Frequency with Hopping
- Gate Output Maximum Voltage Clamped at 17V
- Small SSOT-6 Package

Applications

General-purpose, switching mode, power supplies and flyback power converters, such as:

- Battery Chargers for Cellular Phones, Cordless Phones, PDAs, Digital Cameras, Power Tools
- Power Adapters for Ink Jet Printers, Video Game Consoles, Portable Audio Players
- Open-Frame SMPS for TV/DVD Standby and Auxiliary Supplies, Home Appliances, Consumer Electronics
- Replacement for Linear Transformers and RCC SMPS
- PC 5V Standby Power

Description

This highly integrated PWM controller provides several features to enhance the performance of low-power flyback converters. To minimize standby power consumption, a proprietary green-mode function provides off-time modulation to linearly decrease the switching frequency under light-load and zero-load conditions. This green mode enables the power supply to meet international power conservation requirements. The supply voltage V_{DD} is also used for feedback compensation, to regulate the output voltage without requiring a conventional TL431 and a photo-coupler. Another advantage of the FAN400A is that the typical startup current is only 8μA, while the typical operating current can be as low as 3.6mA. A large startup resistance can be used to achieve even higher power conversion efficiency.

FAN400A integrates a frequency hopping function internally to reduce EMI emissions with minimum line filters. Built-in synchronized slope compensation maintains the stability of peak current-mode control. Proprietary internal compensation ensures constant output power limiting over a universal range of AC input voltages, from 90V_{AC} to 264V_{AC}.

The FAN400A provides many protection functions. Pulse-by-pulse current limiting ensures constant output current, even if a short circuit occurs. The internal protection circuit disables PWM output if V_{DD} exceeds 22.7V. The gate output is clamped at 17V to protect the power MOS from over-voltage damage. The built-in over-temperature protection (OTP) function shuts down the controller at 140°C with a 30°C hysteresis.

The FAN400A is designed to provide a low-cost total solution for flyback converters. It is available in a small-footprint, 6-pin, SSOT-6 package.

Related Resources

- [AN-400A Low-Power Green-Mode PWM Flyback Power Controller without Secondary Feedback](#)

Ordering Information

Part Number	Operating Temperature Range	Package	Eco Status	Packing Method
FAN400ATY	-40°C to +105°C	SSOT-6	Green	Tape & Reel
FAN400ANY	-40°C to +105°C	DIP-8	Green	Tube

Application Diagram

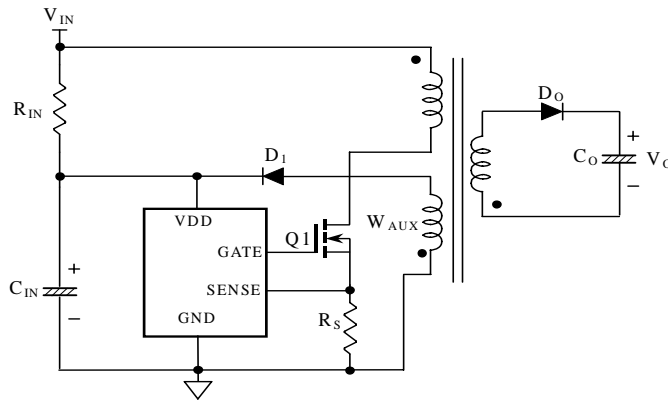

Figure 1. Typical Application

Internal Block Diagram

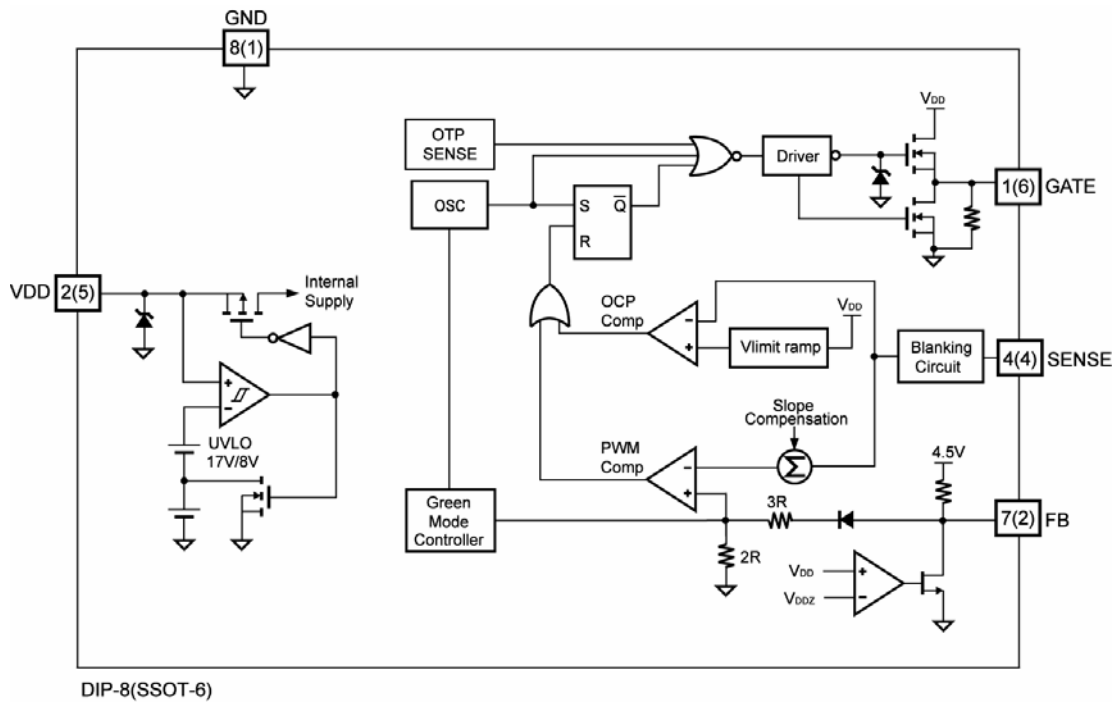
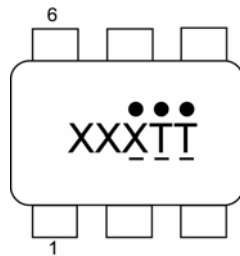

Figure 2. Functional Block Diagram

Marking Information



XXX: AAT=FAN400A

TT : Die run code

. . . : Year code

- - - : Week code

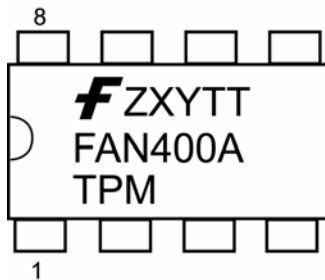

1'st line

Z: Assembly plant code

X: Year code

Y: Week code

TT: Die run code

3'rd line

T: N=DIP

P: Y=Green package

M: Manufacture flow code

Figure 3.

Top Mark

Pin Configuration

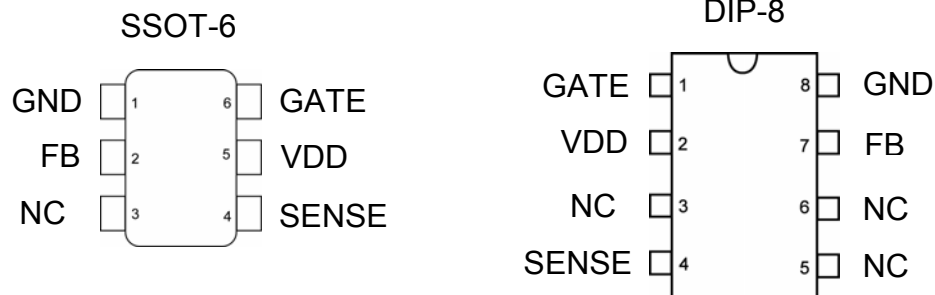

Figure 4.

Pin Configurations

Pin Definitions

DIP Pin #	SSOT Pin #	Name	Description
1	6	GATE	The totem-pole output driver to drive the power MOSFET
2	5	VDD	Power supply
3		NC	No connection
4	4	SENSE	Current sense senses the voltage across a sensed resistor. To provide over-current protection, PWM output is disabled if the voltage exceeds an internal threshold. This pin also provides current information for current-mode control.
5		NC	No connection
6	3	NC	No connection
7	2	FB	The FB pin provides feedback information to the internal PWM comparator. This feedback is used to control the duty cycle. When no feedback is provided, this pin is left open.
8	1	GND	Ground

Absolute Maximum Ratings

Stresses exceeding the absolute maximum ratings may damage the device. The device may not function or be operable above the recommended operating conditions and stressing the parts to these levels is not recommended. In addition, extended exposure to stresses above the recommended operating conditions may affect device reliability. The absolute maximum ratings are stress ratings only.

Symbol	Parameter	Min.	Max.	Unit	
V _{VDD}	DC Supply Voltage ^(1, 2)		30	V	
V _{FB}	Input Voltage to FB Pin	-0.3	7.0	V	
V _{SENSE}	Input Voltage to Sense Pin	-0.3	7.0	V	
T _J	Operating Junction Temperature		+150	°C	
Θ _{JA}	Thermal Resistance (Junction-to-Air)	SSOT		263.3	°C/W
		DIP		135.7	°C/W
T _{STG}	Storage Temperature Range	-55	+150	°C	
T _L	Lead Temperature (Wave Soldering or IR, 10 Seconds)		+260	°C	
ESD	Electrostatic Discharge Capability	Human Body Model JESD22-A114		4	kV
		Machine Model JESD22-A115		200	V

Notes:

1. All voltage values, except differential voltages, are given with respect to GND pin.
2. Stresses beyond those listed under "absolute maximum ratings" may cause permanent damage to the device.

Electrical Characteristics

Unless otherwise noted, $V_{DD}=15V$ and $T_A=25^{\circ}C$.

Symbol	Parameter	Conditions	Min.	Typ.	Max.	Units
V_{DD} Section						
V _{DD-OP}	Continuously Operation Voltage	With Secondary Feedback			20	V
		Without Secondary Feedback			22.7	V
V _{DD-ON}	Turn-on Threshold Voltage		16	17	18	V
V _{DD-OFF}	Turn-off Threshold Voltage		7.5	8.0	8.5	V
I _{DD-ST}	Startup Current	$V_{DD}=V_{DD-ON} - 0.1V$		8	20	μA
I _{DD-OP}	Operating Supply Current	$C_L=1nF$		3.6	4.6	mA
V _{DD-G OFF}	V _{DD} Low-threshold Voltage to Exit Green-off Mode			$V_{DD-OFF}+1.2$		V
Feedback Input Section						
A _V	Input-Voltage to Current-Sense Attenuation			0.3		V/V
Z _{FB}	Input Impedance	$I_{FB}=0.1mA$ to $0.2mA$		4.6		k Ω
V _{FB-OPEN}	Open-Loop Voltage		4.5			V
V _{DD-FB}	V _{DD} Feedback Threshold Voltage	FB is Open	20.7	22.7	24.7	V
		$I_{FB}=0.4mA$	18.4	20.4	22.4	V
Current-Sense Section						
t _{PD}	Propagation Delay			100	150	ns
V _{STHVA}	Current Limit Valley Threshold Voltage	V _{DD} =18V		0.81		V
		V _{DD} =15V		0.73		V
		V _{DD} =10V		0.58		V
V _{STHFL}	Current Limit Flat Threshold Voltage	V _{DD} =18V		1.10		V
		V _{DD} =15V		1.01		V
		V _{DD} =10V		0.81		V
t _{LEB}	Leading-Edge Blanking Time		250	310	370	ns

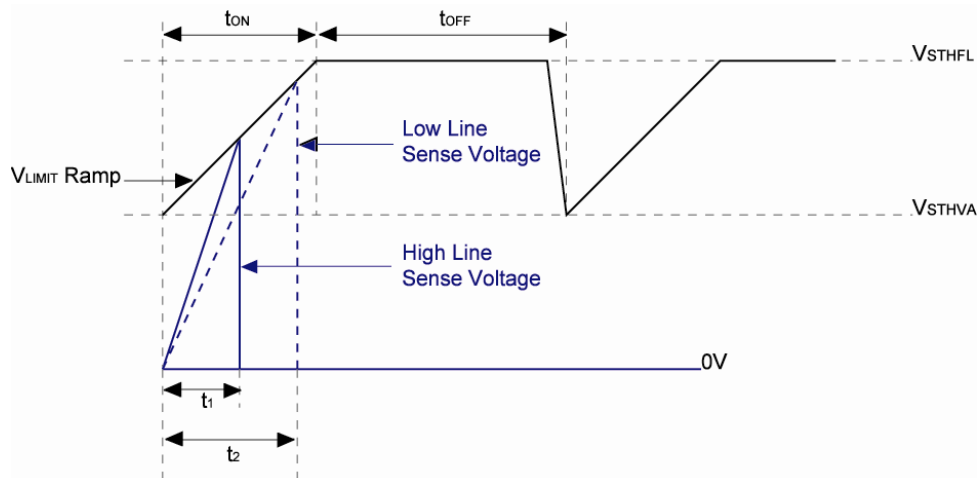

Figure 5. Saw Limit

Electrical Characteristics (Continued)Unless otherwise noted, $V_{DD}=15V$ and $T_A=25^{\circ}C$.

Symbol	Parameter	Conditions	Min.	Typ.	Max.	Units	
Oscillator Section							
f_{OSC}	Frequency	Center Frequency		60	65	70	kHz
		Hopping Range		± 4.1	± 4.6	± 5.1	
t_{HOP}	Hopping Period			4		ms	
f_{OSC-G}	Green Mode Frequency		14.5	17.0	19.5	KHz	
V_{FB-N}	Green Mode Entry FB Voltage		2.3	2.6	2.9	V	
V_{FB-G}	Green Mode Ending FB Voltage			$V_{FB-N} - 0.75$		V	
V_{FB-Z}	Zero Duty Cycle FB Voltage			1.4		V	
S_G	Green Mode Modulation Slope		40	70	100	Hz/mV	
f_{DV}	Frequency Variation vs. V_{DD} Deviation	$V_{DD}=10$ to $22V$			2	%	
f_{DT}	Frequency Variation vs. Temperature Deviation	$T_A=-20$ to $85^{\circ}C$		1.5	5.0	%	
Output Section							
DCY_{MAX}	Maximum Duty Cycle		68	73	78	%	
V_{GATE-L}	GATE Low Voltage	$I_O=10mA$			1.5	V	
V_{GATE-H}	GATE High Voltage	$I_O=-10mA$	8			V	
t_r	GATE Rising Time	$C_L=1nF$	150	200	250	ns	
t_f	GATE Falling Time	$C_L=1nF$	70	90	110	ns	
$V_{GATE-CLAMP}$	GATE Output Clamping Voltage	$V_{DD}=20V$	16	17	18	V	
Over Temperature Protection (OTP)							
T_{OTP}	Protection Junction Temperature			140		$^{\circ}C$	
$T_{OTP-RESTART}$	Restart Junction Temperature			110		$^{\circ}C$	

Typical Performance Characteristics

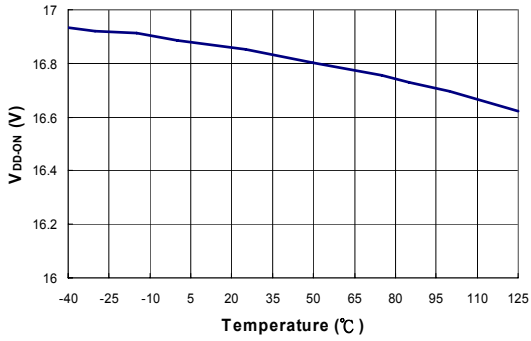

Figure 6. Turn-on Threshold Voltage (V_{DD-ON}) vs. Temperature

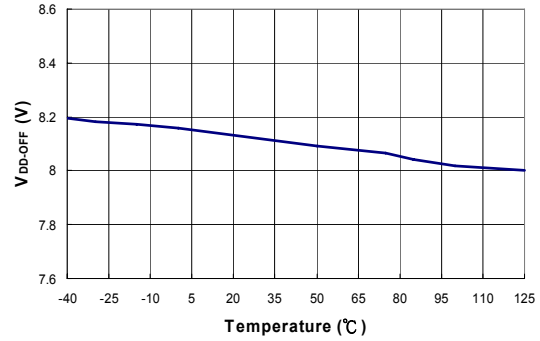

Figure 7. Turn-off Threshold Voltage (V_{DD-OFF}) vs. Temperature

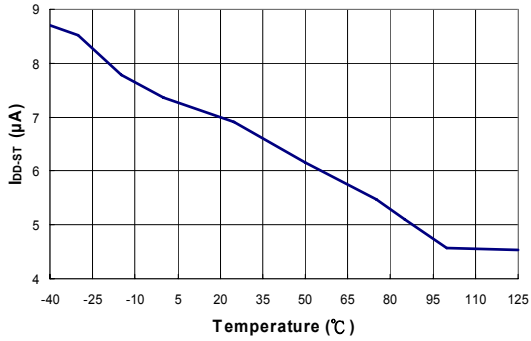

Figure 8. Startup Current (I_{DD-ST}) vs. Temperature

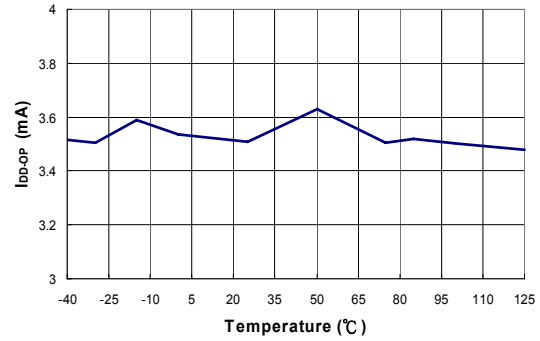

Figure 9. Operating Supply Current (I_{DD-OP}) vs. Temperature

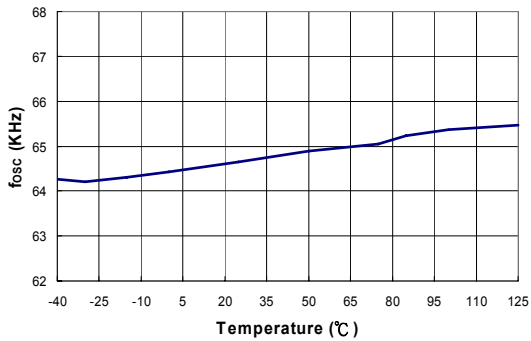

Figure 10. Center Frequency (f_{osc}) vs. Temperature

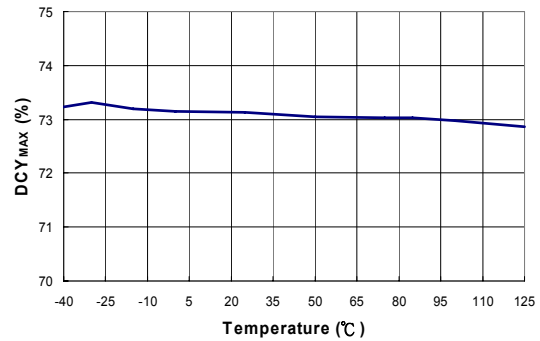

Figure 11. Maximum Duty Cycle (DCY_{MAX}) vs. Temperature

Typical Performance Characteristics

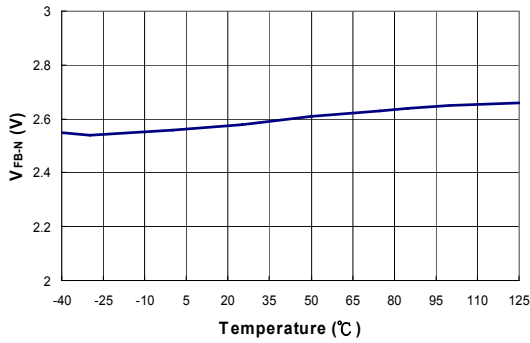

Figure 12. Green-Mode Entry FB Voltage (V_{FB-N}) vs. Temperature

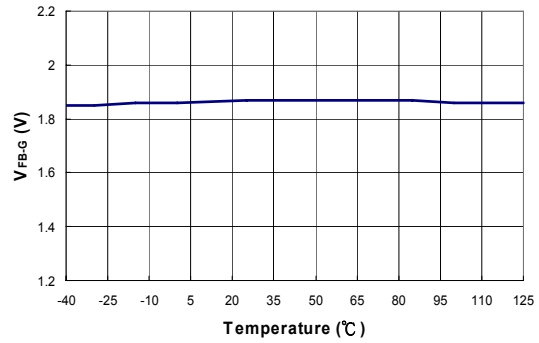

Figure 13. Green-Mode Ending FB Voltage (V_{FB-G}) vs. Temperature

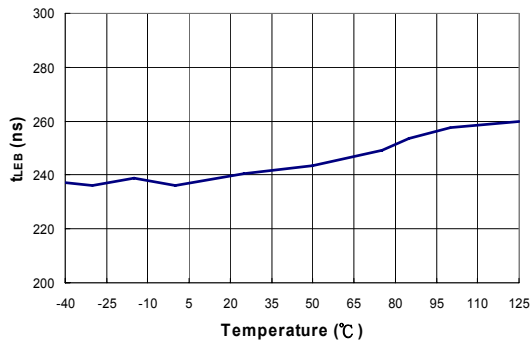

Figure 14. Leading-Edge Blanking Time (t_{LEB}) vs. Temperature

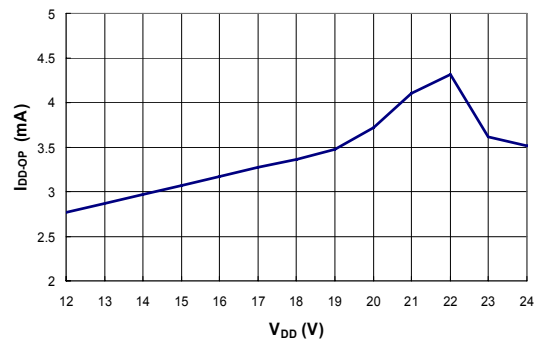

Figure 15. Operating Supply Current vs. V_{DD} Voltage

Operation Description

FAN400A devices integrate many useful functions for low-power switch-mode power supplies. The following descriptions highlight the key features of the FAN400A.

Startup Current

The required startup current is only $8\mu\text{A}$. This allows a high-resistance, low-wattage startup resistor to supply the controller's startup power. A $1.5\text{ M}\Omega/0.25\text{W}$ startup resistor can be used over a wide input range (100V - 240V_{AC}) with very little power loss.

Operating Current

The operating current is normally 3.6mA , which results in higher efficiency and reduces the required V_{DD} hold-up capacitance. A $10\mu\text{F}/25\text{V}$ V_{DD} hold-up capacitor can be used over a wide input range (100V - 240V_{AC}) with very little power loss.

Green-Mode Operation

The proprietary green-mode function provides off-time modulation to linearly decrease the switching frequency under light-load and zero-load conditions. The on-time is limited to provide better protection against brownouts and other abnormal conditions. Power supplies using the FAN400A can meet international restrictions regarding standby power-consumption.

Constant Voltage (CV) and Constant Current (CC) without Feedback

The FAN400A can tightly regulate the output voltage and provide over-current protection without requiring secondary-side feedback signals. For improved CV and CC accuracy, the transformer leakage inductance should be reduced as much as possible.

Over-Temperature Protection (OTP)

The FAN400A has a built-in temperature sensing circuit to shut down PWM output once the junction temperature exceeds 140°C . While PWM output is shut down, the V_{DD} voltage gradually drops to the UVLO voltage. Some of the internal circuits are shut down, and V_{DD} gradually starts increasing again. When V_{DD} reaches 17V , all the internal circuits, including the temperature sensing circuit, operate normally. If the junction temperature is still higher than 140°C , the PWM controller shuts down immediately. This situation continues until the temperature drops below 110°C . The PWM output is then turned back on. The temperature hysteresis window for the OTP circuit is 30°C .

V_{DD} Over-Voltage Clamping

V_{DD} over-voltage clamping is built in to prevent damage from over-voltage conditions. When V_{DD} exceeds 22.7V , PWM output is shut down. Over-voltage conditions may be caused by an open photo-coupler loop or a short circuit in the output.

Oscillator Operation

The oscillation frequency is fixed at 65KHz .

Leading-Edge Blanking (LEB)

Each time the power MOSFET is switched on, a turn-on spike occurs at the sense-resistor. To avoid premature termination of the switching pulse, a 310ns leading-edge blanking time is built in. Conventional RC filtering is not necessary. During this blanking period, the current-limit comparator is disabled and cannot switch off the gate drive.

Constant Output Power Limit

When the SENSE voltage across the sense resistor R_{S} reaches the threshold voltage (around 1.0V), the output GATE drive is turned off following a small propagation delay, t_{PD} . This propagation delay introduces an additional current proportional to $t_{\text{PD}} \cdot V_{\text{IN}}/L_{\text{P}}$. The propagation delay is nearly constant regardless of the input line voltage V_{IN} . Higher input line voltages result in larger additional currents. Under high input-line voltages the output power limit is higher than under low input-line voltages. Over a wide range of AC input voltages, the variation can be significant. To compensate for this, the threshold voltage is adjusted by adding a positive ramp ($V_{\text{limit_ramp}}$). This ramp signal can vary from 0.73V to 1.01V and flattens out at 1.01V . A smaller threshold voltage forces the output GATE drive to terminate earlier, reducing total PWM turn-on time and making the output power equal to that of the low line input. This proprietary internal compensation feature ensures a constant output power limit over a wide range of AC input voltages (90V_{AC} to 264V_{AC}).

Under Voltage Lockout (UVLO)

The turn-on/turn-off thresholds are fixed internally at 17V and 8V . To enable the FAN400A during startup, the hold-up capacitor must first be charged to 17V through the startup resistor. The hold-up capacitor continues to supply V_{DD} before energy can be delivered from the auxiliary winding of the main transformer. V_{DD} must not drop below 8V during this startup process. This UVLO hysteresis window ensures that the hold-up capacitor can adequately supply V_{DD} during startup.

Gate Output

The BiCMOS output stage is a fast totem-pole gate driver. Cross-conduction is avoided to minimize heat dissipation, increase efficiency, and enhance reliability. The output driver is clamped by an internal 17V Zener diode to protect the power MOSFET transistors against any harmful over-voltage gate signals.

Operation Description (Continued)

Slope Compensation

The sensed voltage across the current sense resistor is used for current mode control and pulse-by-pulse current limiting. The built-in slope compensation improves power supply stability. Furthermore, it prevents sub-harmonic oscillations that normally would occur because of peak current mode control. A positively sloped, synchronized ramp is activated with every switching cycle. The slope of the ramp is:

$$\frac{0.33 \times \text{Duty}}{\text{Duty(max.)}} \quad (1)$$

Noise Immunity

Noise from the current sense or the control signal may cause significant pulse-width jitter, particularly in continuous-conduction mode. Slope compensation helps alleviate this problem. Good placement and layout practices should be followed. The designer should avoid long PCB traces and component leads. Compensation and filter components should be located near the FAN400A. Finally, increasing the power-MOS gate resistance is advised.

Applications Information

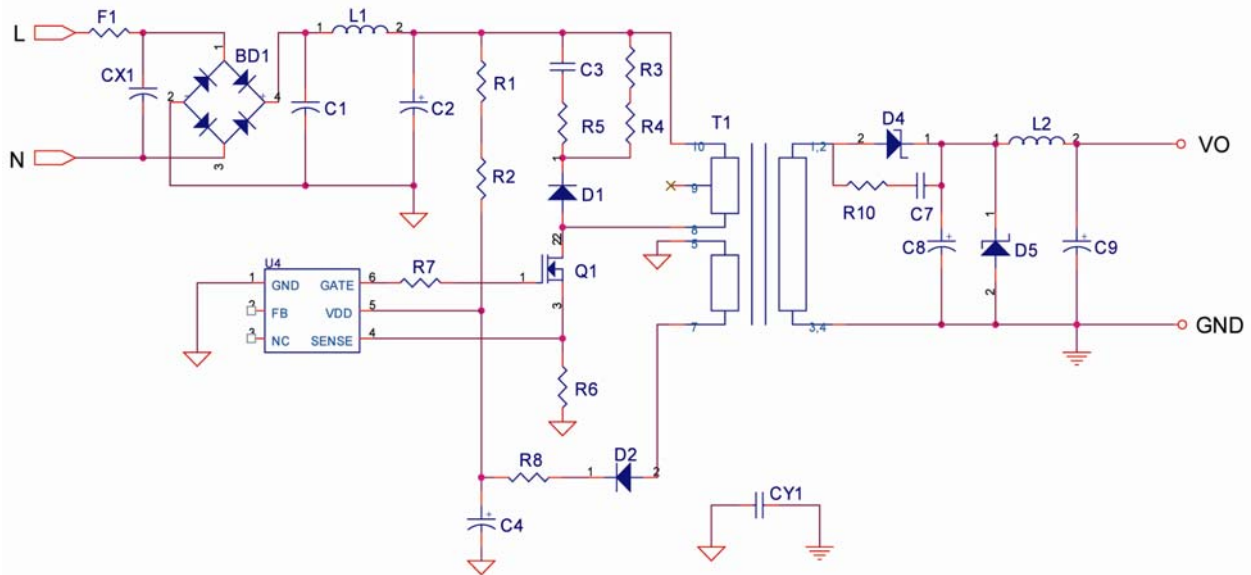

Figure 16. Reference Circuit (without Secondary-Side Feedback)

BOM

Reference	Component	Reference	Component
BD1	BD DI106 1A/600V	F1	R 1Ω/0.5W
CX1 (Option)	YC 4.7nF/400V (Y1)	L1	Inductor 20mH 6*8mm
CY1 (Option)	YC 2.2nF/250V (Y1)	L2	Inductor 10μH 6mm
C1	EC 4.7μF/400V 105°C	Q1	MOSFET 1A/600V
C2	EC 4.7μF/400V 105°C	R1,R2	R 750kΩ/1206
C3	CC 1nF/1kV	R3,R4	R 47kΩ/1206
C4	EC 10μF/50V	R5	R 47Ω/1206
C7 (Option)	CC 1nF/100V 1206	R6	R 4.7Ω/0.5W
C8	EC 470μF/10V 105°C	R7	R 100Ω/0805
C9	EC 220μF/10V 105°C	R8	R 10Ω/1206
D1	Diode FRI07	R10 (Option)	R 10Ω/1206
D2	Diode FR102	T1	Transformer EE-16
D4	Diode SB360	U4	IC FAN400A (Green PWM IC)
D5 (Option)	ZD 6.8V/0.5W		

Applications Information (Continued)

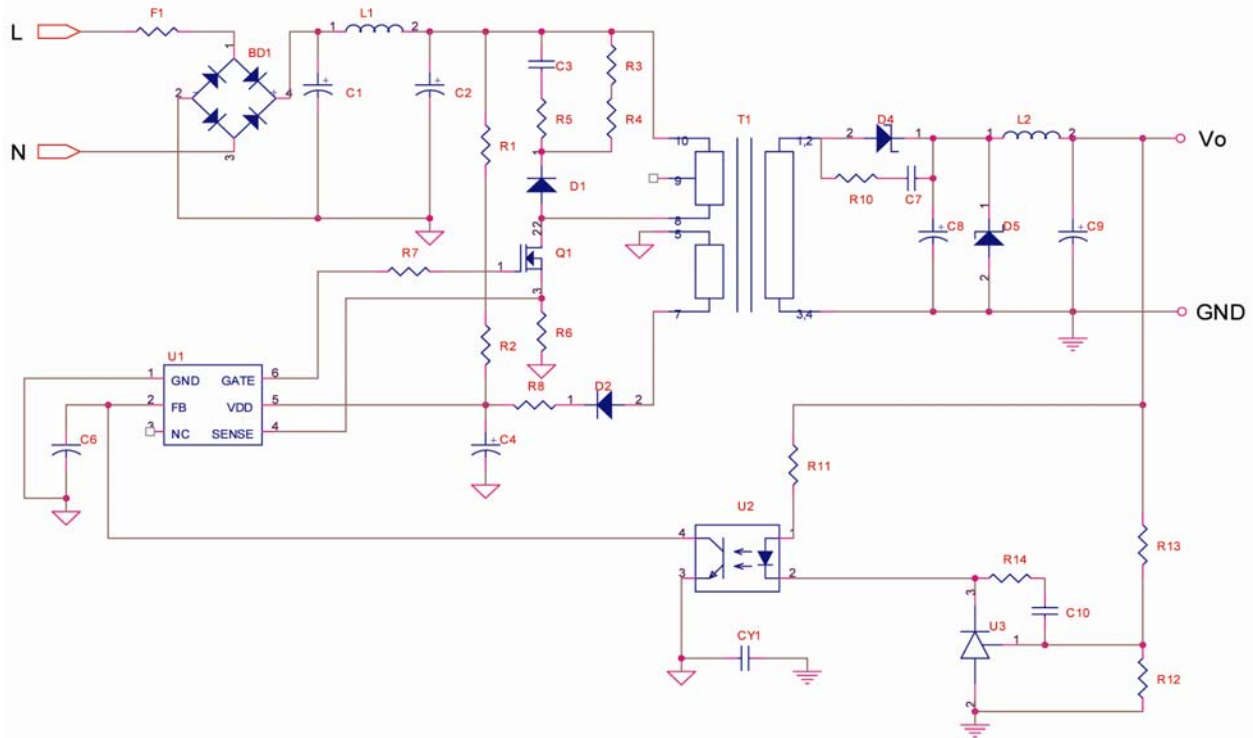
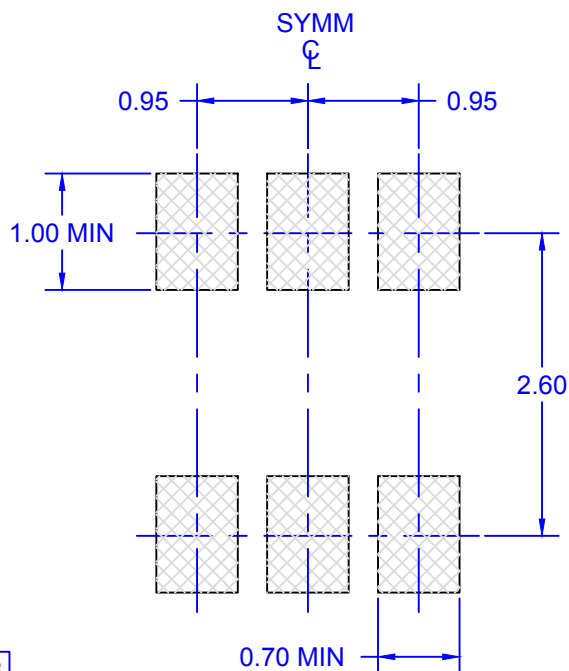
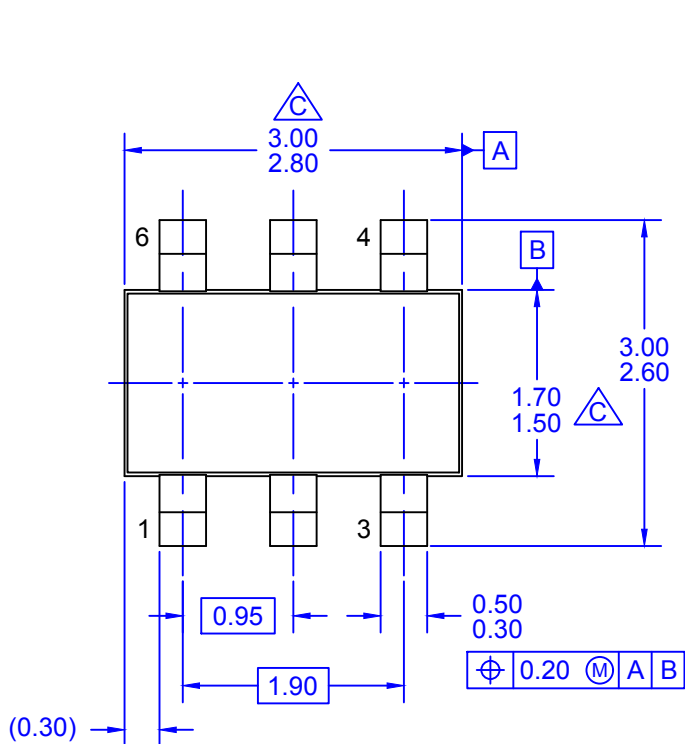

Figure 17. Reference Circuit (with Secondary-Side Feedback)

BOM

Reference	Component	Reference	Component
BD1	BD DI106 1A/600V	L2	Inductor 10 μ H 6mm
CY1 (Option)	YC 2.2nF/250V (Y1)	Q1	MOSFET 1A/600V
C1	EC 4.7 μ F/400V 105 $^{\circ}$ C	R1,R2	R 750 Ω /1206
C2	EC 4.7 μ F/400V 105 $^{\circ}$ C	R3,R4	R 47k Ω /1206
C3	CC 1nF/1kV	R5	R 47 Ω /1206
C4	EC 10 μ F/50V	R6	R 4.7 Ω /0.5W
C6	CC 4.7nF/0805	R7	R 100 Ω /0805
C7 (Option)	CC 1nF/100V 1206	R8	R 10 Ω /1206
C8	EC 470 μ F/10V 105 $^{\circ}$ C	R10	R 10 Ω /1206
C9	EC 470 μ F/10V 105 $^{\circ}$ C	R11	R 100 Ω / 1/8W
C10	CC 2.2nF/0805	R12	R 33k Ω /0805
D1	Diode FRI07	R13	R 33k Ω / 1/8W
D2	Diode FR102	R14	R 4.7k Ω /0805
D4	Diode SB360	T1	Transformer EE-16
D5 (Option)	ZD 6.8V/0.5W	U1	IC FAN400A (Green PWM IC)
F1	R 1 Ω /0.5W	U2	IC PC817
L1	Inductor 20mH 6*8mm	U3	IC TL431



LAND PATTERN RECOMMENDATION

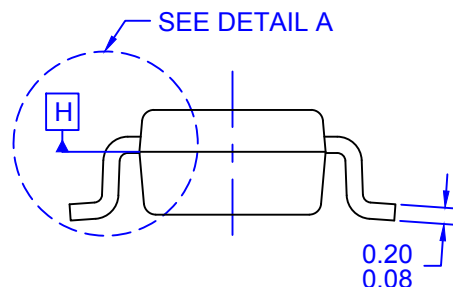
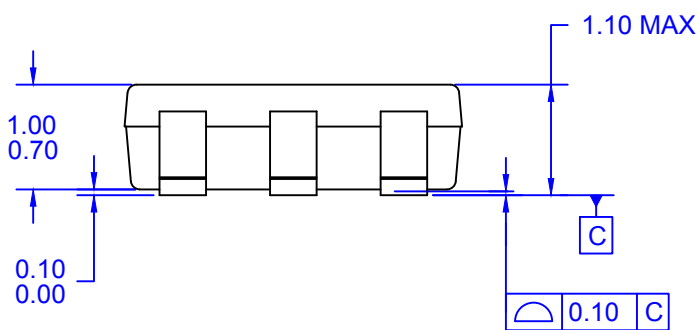

- NOTES: UNLESS OTHERWISE SPECIFIED
- A) THIS PACKAGE CONFORMS TO JEDEC MO-193. VAR. AA, ISSUE E.
 - B) ALL DIMENSIONS ARE IN MILLIMETERS.
 - C) PACKAGE LENGTH DOES NOT INCLUDE MOLD FLASH, PROTRUSIONS OR GATE BURRS. MOLD FLASH, PROTRUSIONS OR GATE BURRS SHALL NOT EXCEED 0.25mm PER END. PACKAGE WIDTH DOES NOT INCLUDE INTERLEAD FLASH OR PROTRUSION. INTERLEAD FLASH OR PROTRUSION SHALL NOT EXCEED 0.25mm PER SIDE. PACKAGE LENGTH AND WIDTH DIMENSIONS ARE DETERMINED AT DATUM H.
 - D) DRAWING FILE NAME: MKT-MA06AREVF

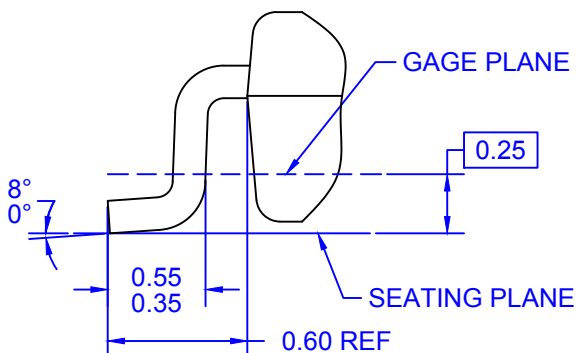

DETAIL A
SCALE: 50X

ON Semiconductor



ON Semiconductor and  are trademarks of Semiconductor Components Industries, LLC dba ON Semiconductor or its subsidiaries in the United States and/or other countries. ON Semiconductor owns the rights to a number of patents, trademarks, copyrights, trade secrets, and other intellectual property. A listing of ON Semiconductor's product/patent coverage may be accessed at www.onsemi.com/site/pdf/Patent-Marking.pdf. ON Semiconductor reserves the right to make changes without further notice to any products herein. ON Semiconductor makes no warranty, representation or guarantee regarding the suitability of its products for any particular purpose, nor does ON Semiconductor assume any liability arising out of the application or use of any product or circuit, and specifically disclaims any and all liability, including without limitation special, consequential or incidental damages. Buyer is responsible for its products and applications using ON Semiconductor products, including compliance with all laws, regulations and safety requirements or standards, regardless of any support or applications information provided by ON Semiconductor. "Typical" parameters which may be provided in ON Semiconductor data sheets and/or specifications can and do vary in different applications and actual performance may vary over time. All operating parameters, including "Typicals" must be validated for each customer application by customer's technical experts. ON Semiconductor does not convey any license under its patent rights nor the rights of others. ON Semiconductor products are not designed, intended, or authorized for use as a critical component in life support systems or any FDA Class 3 medical devices or medical devices with a same or similar classification in a foreign jurisdiction or any devices intended for implantation in the human body. Should Buyer purchase or use ON Semiconductor products for any such unintended or unauthorized application, Buyer shall indemnify and hold ON Semiconductor and its officers, employees, subsidiaries, affiliates, and distributors harmless against all claims, costs, damages, and expenses, and reasonable attorney fees arising out of, directly or indirectly, any claim of personal injury or death associated with such unintended or unauthorized use, even if such claim alleges that ON Semiconductor was negligent regarding the design or manufacture of the part. ON Semiconductor is an Equal Opportunity/Affirmative Action Employer. This literature is subject to all applicable copyright laws and is not for resale in any manner.

PUBLICATION ORDERING INFORMATION

LITERATURE FULFILLMENT:

Email Requests to: orderlit@onsemi.com

ON Semiconductor Website: www.onsemi.com

TECHNICAL SUPPORT

North American Technical Support:
Voice Mail: 1 800-282-9855 Toll Free USA/Canada
Phone: 011 421 33 790 2910

Europe, Middle East and Africa Technical Support:

Phone: 00421 33 790 2910

For additional information, please contact your local Sales Representative