



November 2005

# FAN5616

## High-Efficiency, Constant-Current LED Driver with Adaptive Charge Pump

### Features

- 3-Channel Parallel LED Driver for a Large Range of Forward Voltages
- Adaptive  $V_{OUT}$  Adjustment to the Highest Diode Forward Voltage
- Internally Matched LED Current Sources
- Matched LED Currents with Matched or Unmatched LEDs
- Built-in Charge Pump with Three Modes of Operation: 1x, 1.5x, and 2x
- Up to 90% Efficiency
- Up to 50kHz PWM Dimming Frequency
- Low EMI, Low Ripple
- Up to 120mA Output Current
- Drives up to 3 LEDs at 40mA each
- External Resistor to Set Maximum (100%) LED Current
- Built-in 2-bit DAC to Control LED Current in Digital Mode
- 2.5V to 5.5V Input Voltage Range
- $I_{CC} < 1\mu A$  in Shutdown Mode
- 1MHz Operating Frequency
- Shutdown Isolates Output from Input
- Smart Soft-Start Limits In-Rush Current
- Short Circuit Protection
- Minimal External Components Needed
- Available in a 3x3mm 16-lead MLP Package

### Applications

- Cell Phones
- PDAs, DSCs, and MP3 Players

### Description

The FAN5616 generates a regulated output current from a battery with an input voltage between 2.7V to 5.5V. Switch reconfiguration and fractional switching techniques are utilized to achieve high efficiency over the entire input voltage range. The adaptive nature of the built-in charge pump eliminates the need for LED pre-selection (matching) and ensures operation with high efficiency. The driver's built-in, proprietary, auto-sense circuitry ensures the same high efficiency regardless of the number of LEDs. When the input voltage is sufficiently high to sustain the LED's programmed current level, the FAN5616 reconfigures itself to operate as a linear regulator, and the charge pump is turned off.

The FAN5616 supports both digital and PWM LED brightness control methods. The built-in 2-bit DAC offers a selection of four LED current levels, each level is a percentage of the maximum LED current set by the external  $R_{SET}$  resistor.

The FAN5616 includes built-in shutdown, short circuit and thermal protection circuitry. A built-in smart soft-start circuitry prevents excessive current draw during power on while allowing for an increased PWM frequency for dimming.

Minimal external components are required. Only two 0.1 $\mu F$  to 1 $\mu F$  bucket capacitors, a 4.7 $\mu F$  input capacitor and a 1 $\mu F$  output capacitor are needed for proper operation.

The FAN5616 is available in a 3x3mm 16-lead MLP package.

### Ordering Information

Product Number	Package Type	Order Code
FAN5616	3x3mm 16-Lead MLP	FAN5616MPX

**FAN5616 High-Efficiency, Constant-Current LED Driver with Adaptive Charge Pump**

### Typical Application

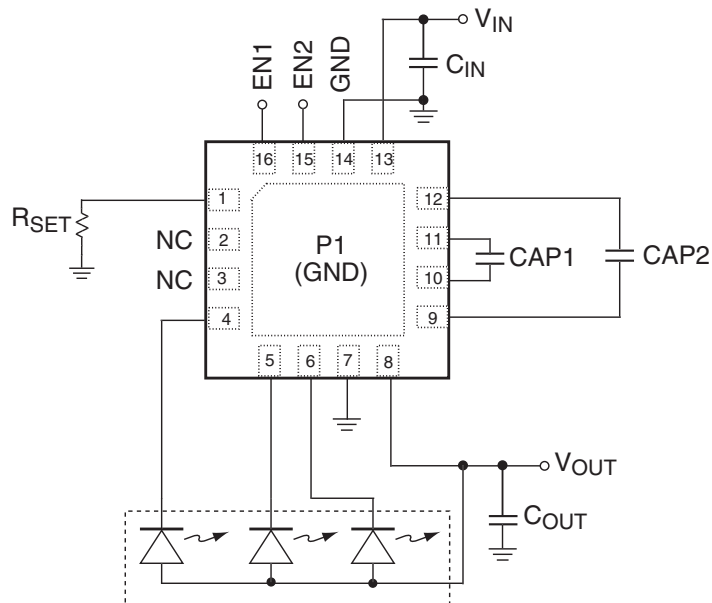

Figure 1. Typical Application

### Pin Assignment

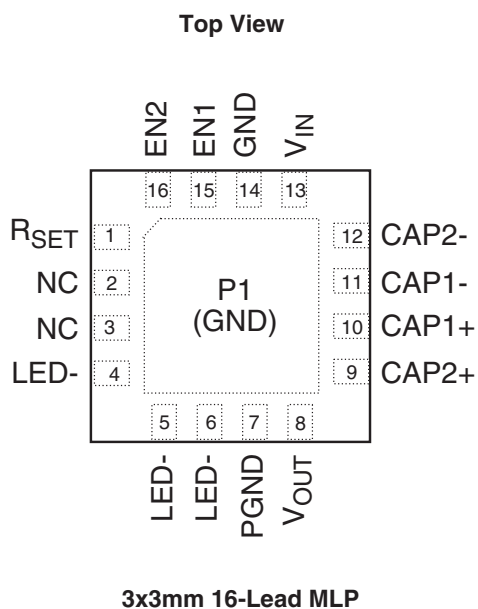

Figure 2. Pin Assignment

## Pin Description

Pin No.	Pin Name	Pin Description
P1	GND	<b>Ground.</b> P1 must be soldered to the PCB ground.
1	R <sub>SET</sub>	<b>R<sub>SET</sub> Pin.</b> Connect this pin to the resistor used to set the maximum LED current.
2	NC	<b>No Connection.</b>
3	NC	<b>No Connection.</b>
4	LED-	<b>1st LED Cathode.</b> Connect this pin to the LED's cathode.
5	LED-	<b>2nd LED Cathode.</b> Connect this pin to the LED's cathode.
6	LED-	<b>3rd LED Cathode.</b> Connect this pin to the LED's cathode.
7	PGND	<b>Power Ground.</b>
8	V <sub>OUT</sub>	<b>Output Voltage.</b> Connect this pin to all of the LED's anodes.
9	CAP2+	<b>Bucket Capacitor 2.</b> Connect this pin to the positive terminal of the bucket capacitor.
10	CAP1+	<b>Bucket Capacitor 1.</b> Connect this pin to the positive terminal of the bucket capacitor.
11	CAP1-	<b>Bucket Capacitor 1.</b> Connect this pin to the negative terminal of the bucket capacitor.
12	CAP2-	<b>Bucket Capacitor 2.</b> Connect this pin to the negative terminal of the bucket capacitor.
13	V <sub>IN</sub>	<b>Supply Voltage Input.</b>
14	GND	<b>Ground.</b>
15	EN1	<b>Enable Input.</b>
16	EN2	<b>Enable Input.</b>

**Absolute Maximum Ratings** (Note1)

Parameter	Min	Max	Unit
V <sub>IN</sub> , V <sub>OUT</sub> , EN1, EN2, GND	-0.3	6	V
Voltage On All Other Pins	GND – 0.3	V <sub>IN</sub> + 0.3	V
CAP+, CAP- to GND	-0.3	V <sub>IN</sub> + 0.3	V
Thermal Resistance – Junction to Tab ( $\theta_{JC}$ ) (Note 2)		8	°C/W
Lead Soldering Temperature (10 seconds)		260	°C
Junction Temperature		150	°C
Storage Temperature	-65	150	°C
Electrostatic Discharge Protection (ESD) Level (Note 3)	HBM	2.5	kV
	CDM	1.5	

**Recommended Operating Conditions**

Parameter	Min	Max	Unit
Supply Voltage Range	2.5	5.5	V
LED Forward Voltage		4	V
Current Through Each LED	2	40	mA
PWM Dimming Signal Frequency	0.2	50	kHz
Operating Ambient Temperature	-40	+85	°C
Operating Junction Temperature	-40	+125	°C

**Notes:**

- Stresses above those listed under “Absolute Maximum Ratings” may cause permanent damage to the device. This is a stress rating only and functional operation of the device at these or any other conditions above those indicated in the operational section of this specification is not implied. Exposure to absolute maximum rating conditions for extended periods may affect device reliability. Absolute maximum ratings apply individually only, not in combination. Unless otherwise specified all other voltages are referenced to GND.
- Junction to ambient thermal resistance,  $\theta_{JA}$ , is a strong function of PCB material, board thickness, thickness and number of via used, diameter of via used, available copper surface, and attached heat sink characteristics. A reasonable estimated value for  $\theta_{JA}$  for zero air flow at 0.5W is 60°C/W.
- Using Mil Std. 883E, method 3015.7(Human Body Model) and EIA/JESD22C101-A (Charge Device Model).

## Electrical Characteristics

Unless otherwise noted,  $V_{IN} = 2.7V$  to  $5.5V$ ,  $I_{LED} = 2mA$  to  $20mA$ ,  $EN1 = EN2 = HIGH$ ,  $T_A = -40^{\circ}C$  to  $+85^{\circ}C$ . Typical values are at  $25^{\circ}C$ .

Parameter	Conditions	Min	Typ	Max	Unit
Input Under-Voltage Lockout	$V_{IN}$ falling			1.6	V
	$V_{IN}$ rising	2.3			
$I_{LED}/I_{SET}$ Ratio	$V_{IN} = 3.6V$ , $I_{OUT} = 15mA$	240	255	270	
$I_{LED}/I_{SET}$ Ratio	$I_{LED} = 2$ to $20mA$	230	260	280	
$I_{LED}/I_{SET}$ Ratio	$EN1 = HIGH$ , $EN2 = LOW$		86		
	$EN1 = LOW$ , $EN2 = HIGH$		173		
Current Matching with Unmatched LEDs (Note 1)	$2mA \leq I_{LED} \leq 15mA$ $2.8V \leq LED V_F < 4V$		0.6	+3	%
Reference Voltage for Current Set		588	600	612	mV
Start Up time	$C_{OUT} = 1\mu F$ , $V_{IN} = 3.6V$ , $I_{LED} = 15mA$	200	270	500	$\mu S$
Minimum Cathode Voltage	$I_{LED} = 15mA$		170	250	mV
Quiescent Current	$V_{IN} = 5.5V$ , $I_{OUT} = 5mA$		250		$\mu A$
Shutdown Supply Current	$EN1 = EN2 = Logic "L"$		0.1	1	$\mu A$
Output Short Circuit Current	$V_{IN} = 5.5V$ , $V_{OUT} = 0V$		65	80	mA
$V_{OUT}$ Over-voltage Protection				6	V
$V_{IN}$ at Mode Transition from 1x to 1.5x	$LED V_f = 3.5V$ , $I_{LED} = 3 \times 20mA$		3.9		V
$V_{IN}$ at Mode Transition from 1.5x to 2x	$LED V_f = 3.5V$ , $I_{LED} = 3 \times 20mA$		2.9		V
Peak Efficiency (Note 2)	$V_{IN} = 3.75V$ , $LED V_f = 3.4V$ , $I_{LED} = 18mA$		90		%
Oscillator Frequency		0.8	1	1.2	MHz
Thermal Shutdown Threshold			150		$^{\circ}C$
Thermal Shutdown Hysteresis			15		$^{\circ}C$
"EN1" Logic Input Low Voltage				0.4	V
"EN1" Logic Input High Voltage		1.6			V
"EN2" Logic Input Low Voltage				0.4	V
"EN2" Logic Input High Voltage		1.6			V

### Notes:

- Current Matching refers to the absolute value of the difference in the current between the two LED branches.

$$\text{Current Matching (\%)} \equiv \left| \frac{(I_{LEDi} - I_{LEDj}) \times 100}{(I_{LEDi} + I_{LEDj})} \right|, \text{ where } i, j = 1, 2 \text{ or } 3$$

- Efficiency is expressed as a ratio between the electrical power into the LEDs and the total power consumed from the input power supply.

$$\text{Efficiency} \equiv \frac{\sum_{i=1}^3 V_{LEDi} \times I_{LEDi}}{V_{IN} \times I_{IN}}$$

Some competitors calculate the efficiency as a function of  $V_{OUT}$  instead of LED  $V_F$ . Their method does not account for the power lost due to the cathode voltage not being equal to zero. This method allows them to provide an "improved" efficiency up to 5%.

### Typical Performance Characteristics

Unless otherwise noted,  $V_{IN} = 3.6V$ ,  $T_A = 25^\circ C$ ,  $C_{IN} = 4.7\mu F$ ,  $C_{OUT} = 1\mu F$ ,  $CAP1 = CAP2 = 0.1\mu F$ , FAN5616 driving three LEDs with  $V_F = 3.5V$  at  $20mA$ .

**Efficiency vs. Battery Voltage**

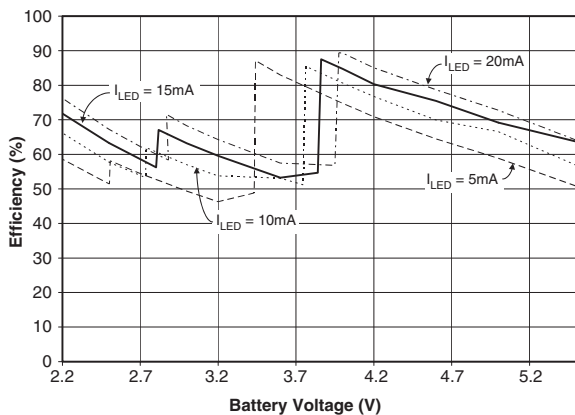

**LED Current vs. Battery Voltage**

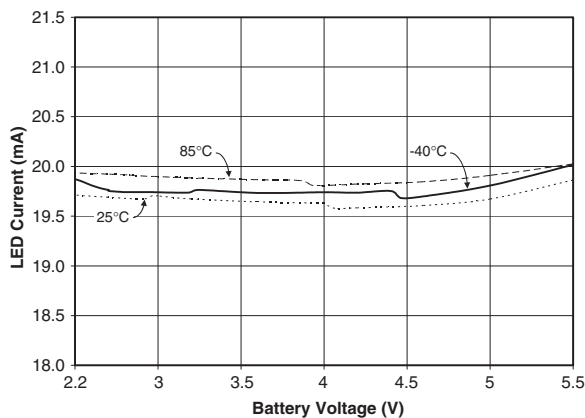

**Minimum Cathode Voltage vs. LED Current**

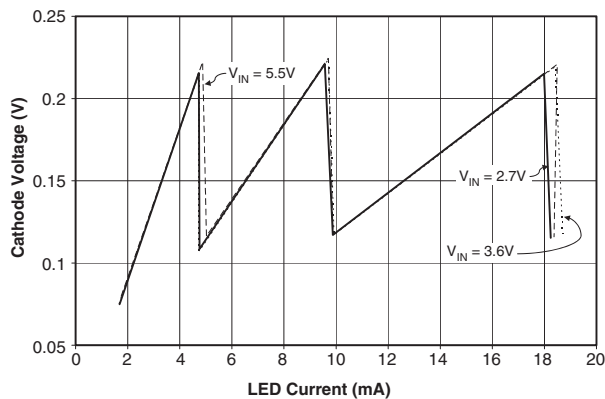

**Quiescent Current vs. Battery Voltage**

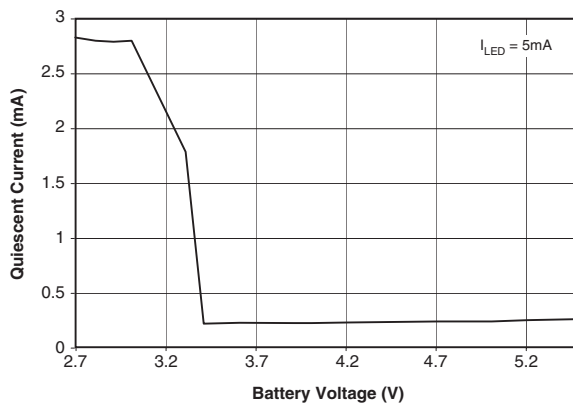

**Output Voltage vs. Output Current**

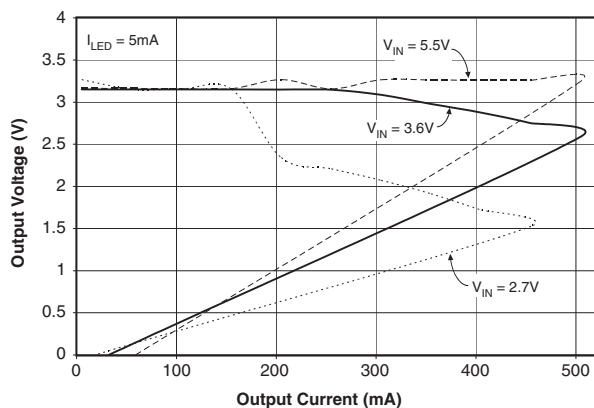

**LED Current vs. Duty Cycle**

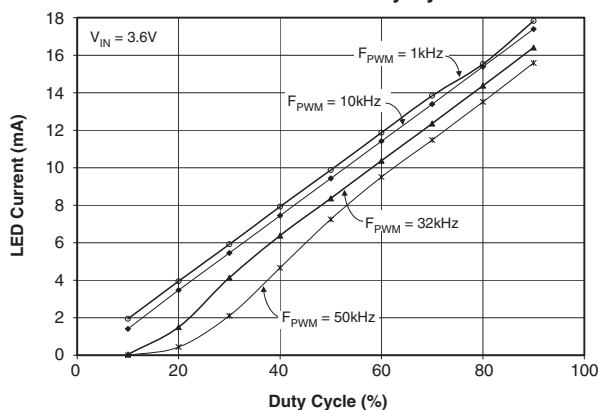

### Typical Performance Characteristics (Continued)

Unless otherwise noted,  $V_{IN} = 3.6V$ ,  $T_A = 25^\circ C$ ,  $C_{IN} = 4.7\mu F$ ,  $C_{OUT} = 1\mu F$ , CAP1 = CAP2 =  $0.1\mu F$ , FAN5616 driving three LEDs with  $V_F = 3.5V$  at 20mA.

**LED Current vs. PWM Frequency**

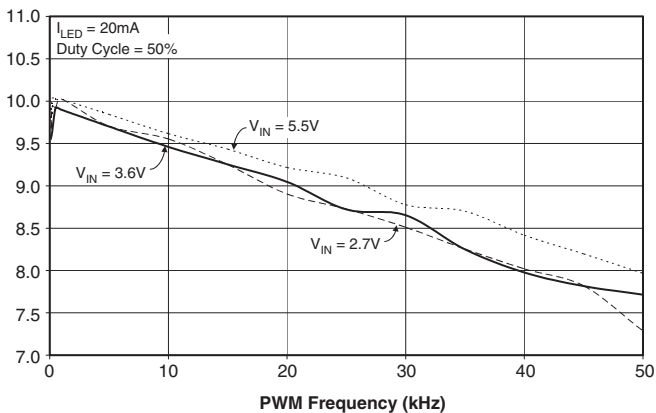

**LED Current Waveform at Highest  $F_{PWM}$**

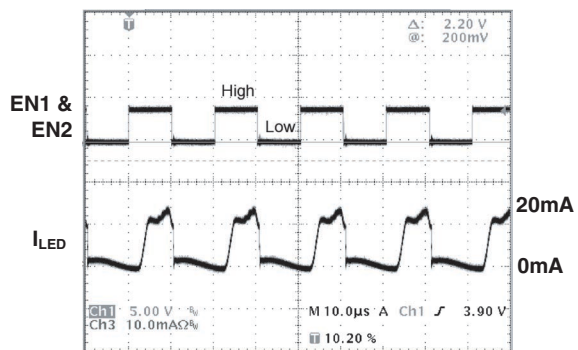

**Soft-Start Response**

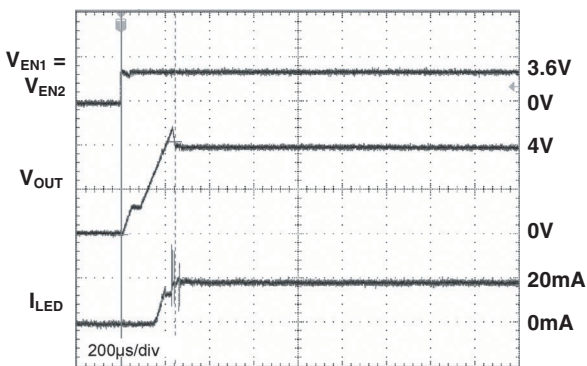

**Smart Soft-Start Response**

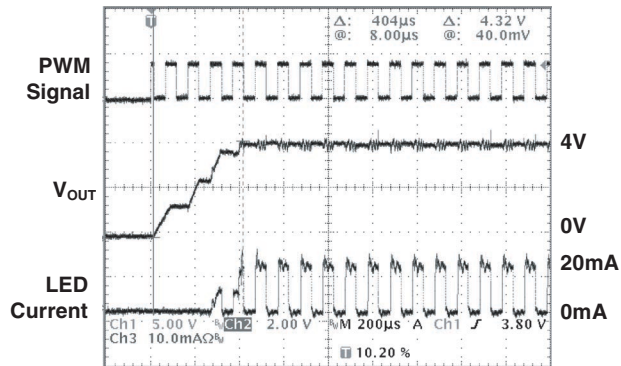

## Block Diagram

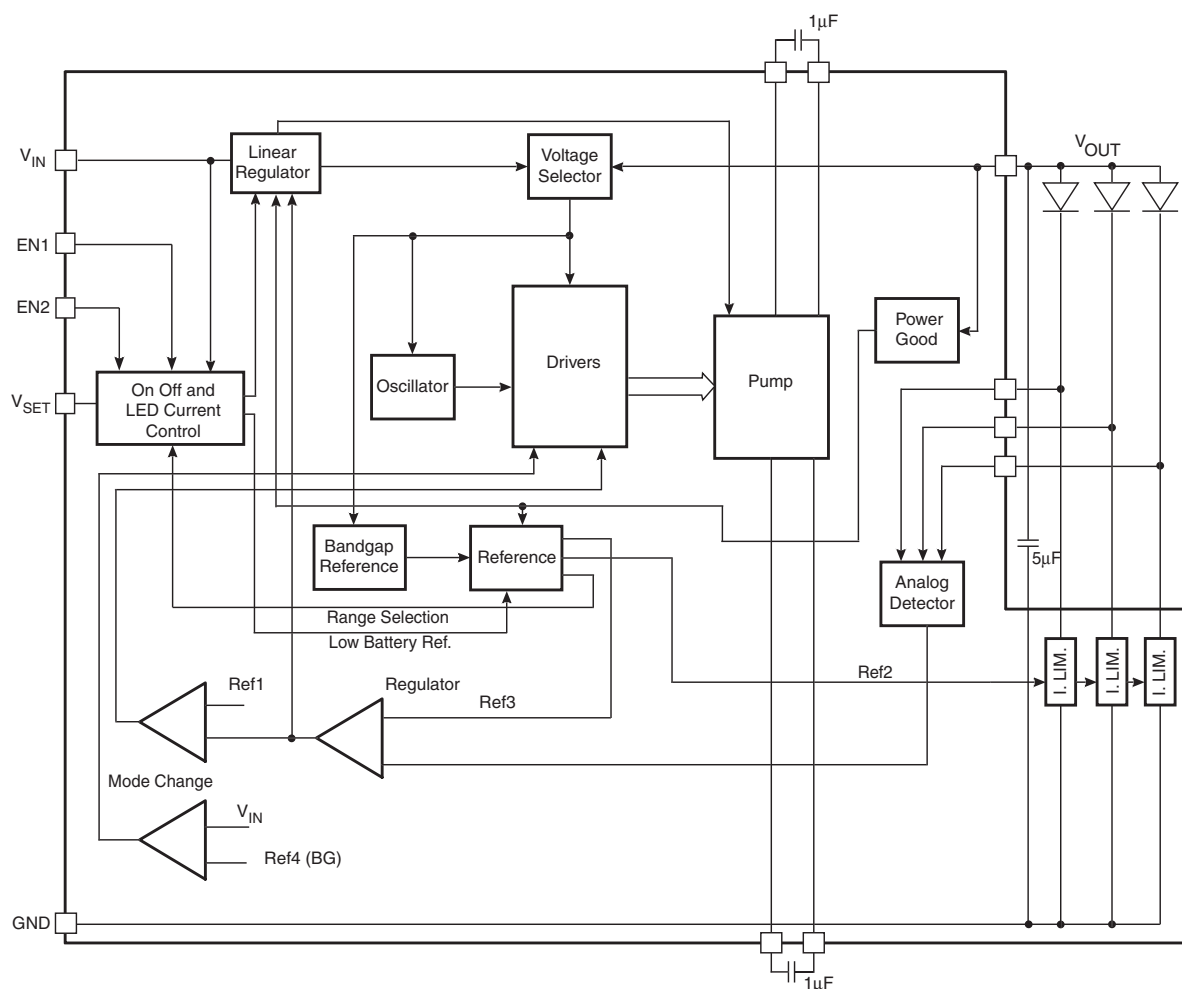

Figure 3. Block Diagram

## Circuit Description

As shown in Figure 4, the FAN5616's switch capacitor DC/DC converter automatically configures its internal switches to achieve high efficiency and to provide tightly-regulated output currents for the LEDs. An analog detector determines which diode requires the highest voltage in order to sustain the pre-set current levels, and adjusts the pump regulator accordingly. Every diode has its own linear current regulator. In addition, a voltage regulator controls the output voltage when the battery voltage is within a range where linear regulation can provide maximum possible efficiency. If the battery voltage is too low to sustain the diode current in linear mode, a fractional 3:2 charge pump is enabled. When the battery voltage drops and the mode is no longer sufficient to sustain proper operation, the pump is automatically reconfigured to operate in 2:1 mode. As the battery discharges and the voltage decays, the FAN5616 switches between

modes to maintain a constant current through the LEDs throughout the battery life. This transition has hysteresis to prevent toggling.

The internal supply voltage of the device is automatically selected from the  $V_{IN}$  or  $V_{OUT}$  pins, whichever has a higher voltage.

The FAN5616 enters shutdown mode to reduce overall current consumption when both DAC inputs (EN1 and EN2) are low.

## Short Circuit and Thermal Protection

In the event of an output voltage short circuit, the output current will be limited to a typical value of 65mA.

In addition, when the die temperature exceeds 150°C, a reset occurs and remains in effect until the die cools to 135°C. At which time the circuit will restart and resume normal operation.



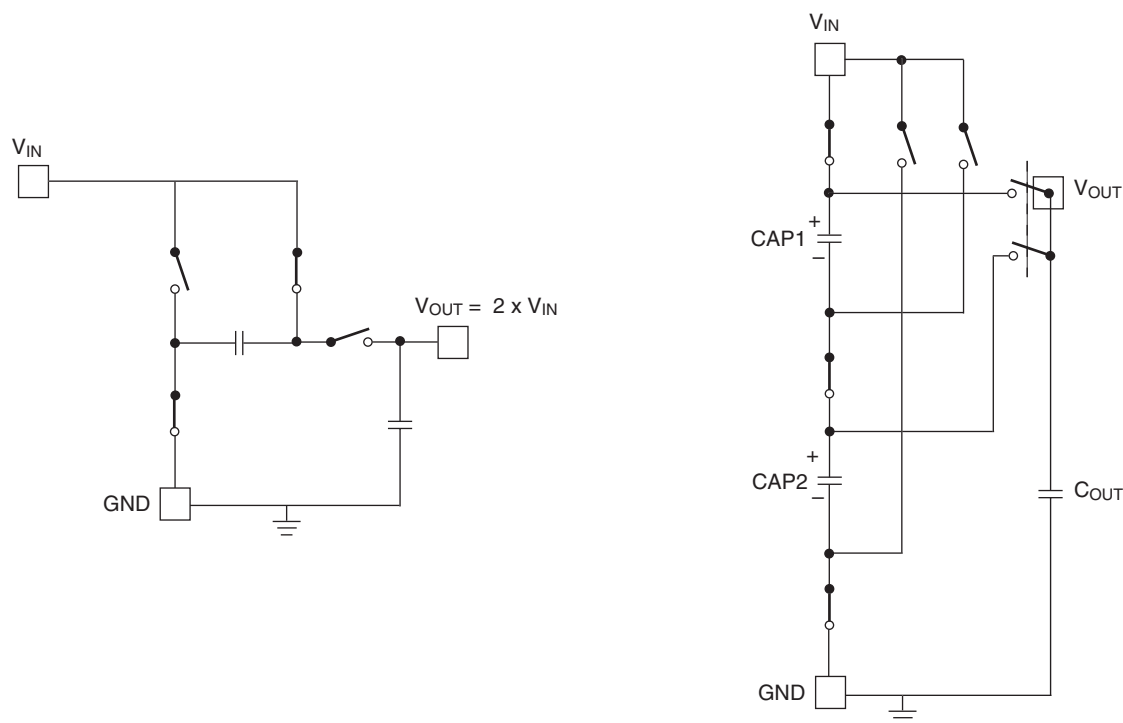

Figure 4. Switch Configuration

### Smart Soft-Start

When the FAN5616 is enabled, the Smart Soft-Start circuit limits the switcher's in-rush current. Figure 5 shows the timing diagram of the Smart Soft-Start circuit and associated signals.

After a power up, the FAN5616 is placed in low power mode until a logic "High" is applied to the enable (EN1/EN2) pin enabling the device. Within the first 500 $\mu$ S of enabling the device the output voltage ( $V_{OUT}$ ) is increased linearly until it reaches its nominal level. When a logic "Low" is applied to EN1/EN2 for more than 5mS, the device is placed in a low power mode and the output voltage is turned off. The LED current is controlled by applying a PWM signal to the EN1/EN2 pin. To avoid interference between the PWM signal and the soft-start circuit, the PWM signal applied must be faster than 200Hz but not greater than 50kHz. The soft-start circuit will be reactivated with each low to high transition on the EN1/EN2 pin. As shown in Figure 5, the PWM signal, ideally, should be controlled so that the initial logic "High"

is at least 250 $\mu$ S before returning to its standard frequency. This allows  $V_{OUT}$  to ramp to its nominal level. However, as shown in Figure 6, in most cases a frequency greater than a 1kHz PWM signal is applied to the EN1/EN2 pin such that the  $V_{OUT}$  ramp rate slows accordingly. The  $V_{OUT}$  ramp will begin during the initial high level (ON state) of the PWM signal while its voltage will be maintained during its low level (OFF state).

The following formula explains the relationship between duty cycle (D) and soft-start  $V_{OUT}$  ramp time ( $T_{STR}$ ),

$$T_{STR} \approx \frac{250\mu S}{D}$$

$$\text{Where, } D = \frac{T_{ON}}{T_{ON} + T_{OFF}}$$

For example, a PWM signal with a 50% duty ratio ( $D=0.5$ ) generates a 500 $\mu$ S soft-start  $V_{OUT}$  ramp.

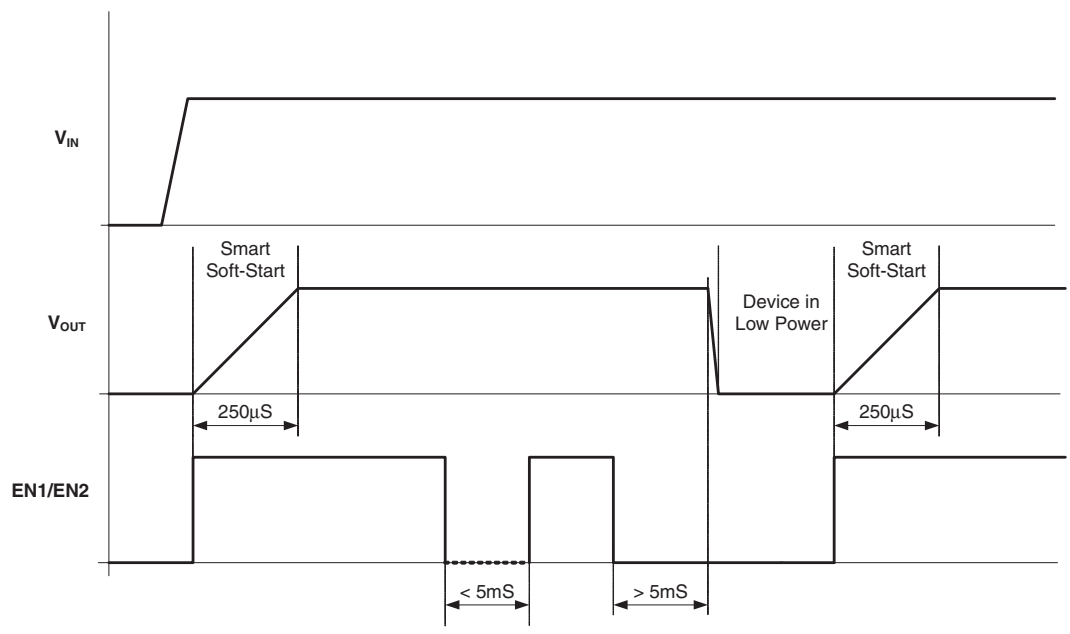

Figure 5. Smart Soft-Start Timing

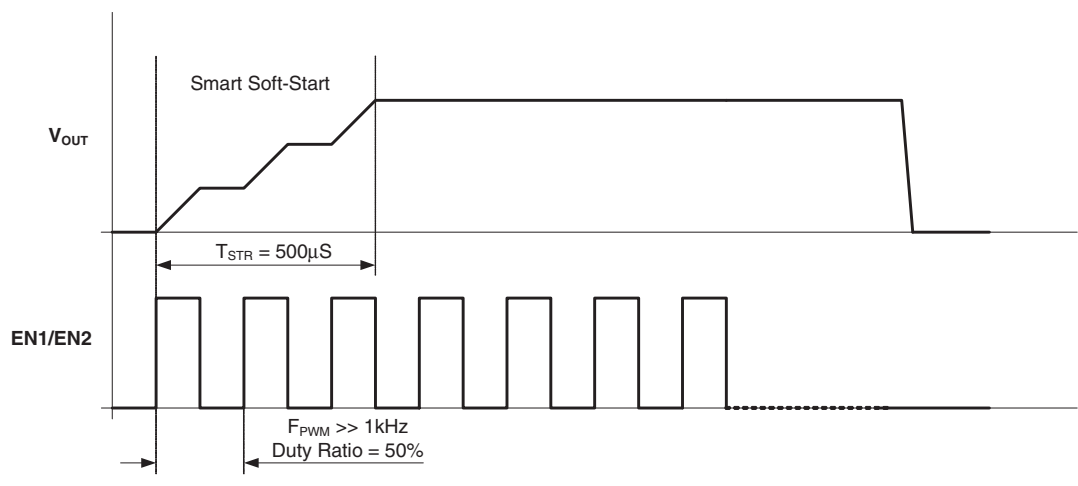

Figure 6. Smart Soft-Start Timing with 50% PWM

### Application Information

#### LED Brightness Control Methods

##### 1. External RSET Resistor

The external RSET resistor sets the maximum LED current for LED brightness control.

The resistor value establishes the reference current needed for a constant LED current. To calculate different RSET values, use the formula below:

$$R_{SET} = \frac{156}{I_{LED}}$$

Table 1. Max. ILED (EN1=EN2 = Logic “High”)

RSET (kΩ)	7.8	15.6	31.2	62.4
ILED-MAX (mA)	20	10	5	2.5

## 2. Digital Control

A built-in 2-bit DAC is used to digitally control the LED's brightness through the EN1 and EN2 inputs. Once the desired maximum LED current is set by the external  $R_{SET}$  resistor, the percentage of the maximum LED current is selected, as described in Table 2, to perform the dimming operation.

**Table 2. LED Dimming with Internal 2-bit DAC**

EN2	EN1	LED Current % of Maximum
0	0	0%
0	1	33.3% (1/3)
1	0	66.7% (2/3)
1	1	100% (3/3)

## 3. PWM Control

In addition to the digital LED brightness control, the FAN5616 features a PWM control. The LED current varies according to the width of the PWM signal applied to the EN1/EN2 input pins. Once the desired maximum LED current ( $I_{LED-MAX}$ ) is set by the external  $R_{SET}$  resistor, the percentage of  $I_{LED-MAX}$  to perform the dimming operation depends on the configuration of the PWM signal with respect to the 2-bit DAC inputs (EN1 and EN2) as described in Table 2.

For example, if  $R_{SET} = 7.8k\Omega$  then  $I_{LED-MAX} = 20mA$ . If EN1 and EN2 are tied together and a PWM signal is applied, the LED current will vary between 0% and 100% (0mA and 20mA) of the maximum LED current according to the duty cycle of the PWM signal.

The PWM signal can be applied to either enable input pins (EN1/EN2) or to both tied together. Depending upon the configuration, the average LED current can be adjusted within any range limited by 0, 1/3, 2/3, 3/3 of the maximum LED current as described in Table 3. The PWM duty cycle is assumed to be between 10% and 90%.

**Table 3. Average LED Dimming Range**

Enable Input Pins		Average $I_{LED}$ Adjustment Range
EN2	EN1	
LOW	TOGGLE	3% to 30% of $I_{LED-MAX}$
HIGH	TOGGLE	70% to 97% of $I_{LED-MAX}$
TOGGLE	LOW	6% to 60% of $I_{LED-MAX}$
TOGGLE	HIGH	39% to 93% of $I_{LED-MAX}$
TOGGLE	TOGGLE	10% to 90% of $I_{LED-MAX}$

The recommended PWM frequency range is 200Hz to 50kHz for an acceptable linear response. At higher frequencies, the current waveform can no longer follow the PWM signal waveform, resulting in a significant difference between the value of the average  $I_{LED}$  and the theoretical calculation.

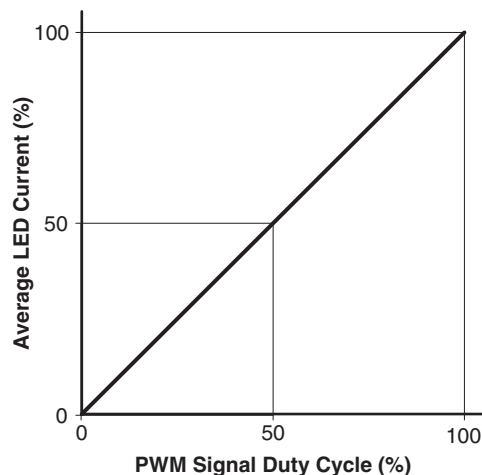

**Figure 7. Ideal PWM Dimming Response**

## 4. Dimming with DC Voltage

The brightness control using a variable DC voltage is shown in Figure 8. If  $R1 = 78k\Omega$ ,  $R2 = 7.8k\Omega$ , adjusting  $V_{EXT}$  in the 0V to 0.6V range results in dimming the LED current from 22mA to 2mA.

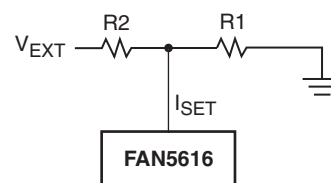

**Figure 8. DC Voltage Control**

The FAN5616's internal circuit maintains a constant  $V_{SET} = 0.6V$ . Adjusting  $V_{EXT}$  changes the  $I_{SET}$  and  $I_{LED}$  accordingly.

By selecting different values for  $R1$ ,  $R2$  and  $V_{EXT}$ , the  $I_{LED}$  variation range can be changed according to the following equation:

$$I_{LED} = \left[ \frac{156}{R1} + \frac{(156 - 260 \times V_{EXT})}{R2} \right] \text{mA}$$

Where,  $0V < V_{EXT} < 0.6V (1+R2/R1)$  and  $R1$  and  $R2$  are in  $k\Omega$ .

## Selecting Capacitors

It is important to select the appropriate capacitor types and the values for use with the FAN5616. In order to reduce battery ripple, both  $C_{IN}$  and  $C_{OUT}$  should be low-ESR capacitors. If necessary, the ripple can be further reduced by powering the FAN5616 through an RC input filter, as shown in Figure 9.

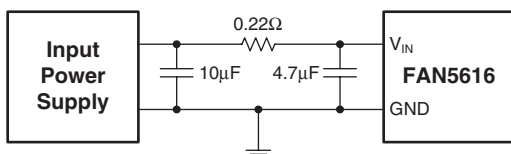
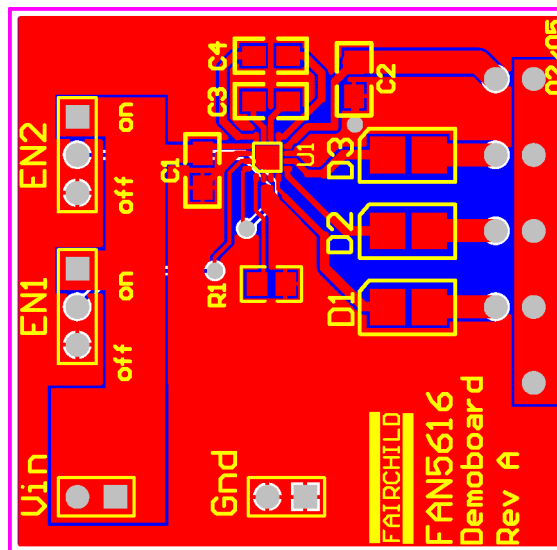

**Figure 9. Battery Ripple Reduction**

Two MLCC bucket capacitors of  $0.1\mu\text{F}$  to  $1\mu\text{F}$  should be used for best efficiency in boost mode. For better  $I_{LED}$  regulation,  $1\mu\text{F}$  bucket capacitors are recommended particularly when  $I_{LED} > 25\text{mA}$  and the battery discharges below 3V.

## PCB Layout Considerations

For best performance, a solid ground plane is recommended on the back side of the PCB. All capacitors should be placed as close to the FAN5616 as possible and connected with reasonably thick traces to minimize the ESL and ESR parasitics.



**Figure 10. Recommended PCB Layout**

### Mechanical Dimensions

#### 3x3mm 16-Lead MLP

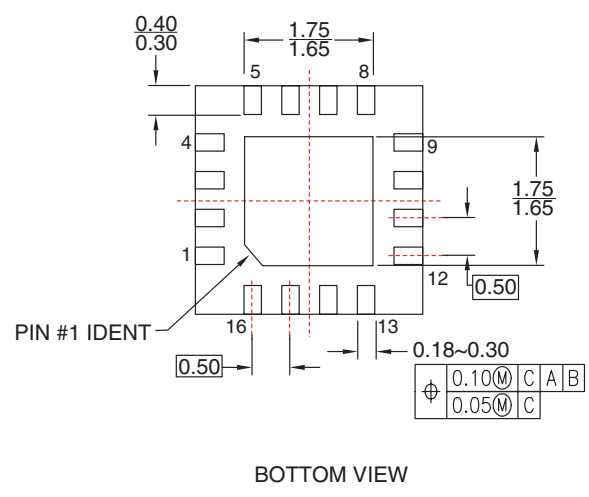
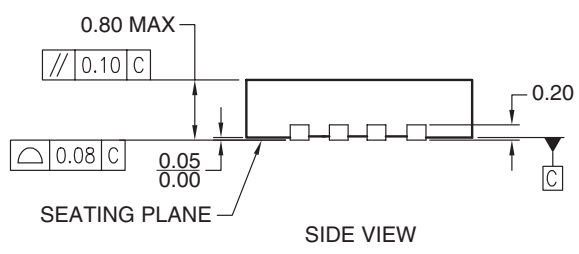
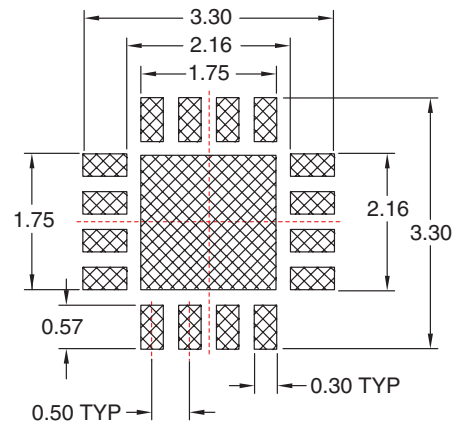
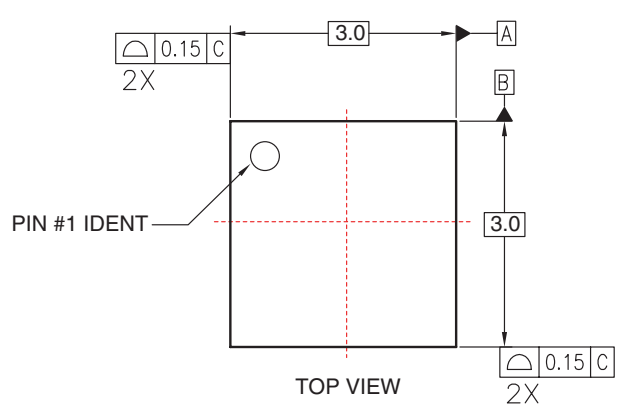

- Notes:**
1. Conforms to JEDEC registration MO-220, variation weed-pending, dated pending.
  2. Dimensions are in millimeters.
  3. Dimensions and tolerances per ASME Y14.5M, 1994.
  4. Dimensions are exclusive of burs, mold flash, and tie bar extrusions.

MLP16B rev B

**TRADEMARKS**

The following are registered and unregistered trademarks Fairchild Semiconductor owns or is authorized to use and is not intended to be an exhaustive list of all such trademarks.

ACE <sup>™</sup>	FAST <sup>®</sup>	ISOPLANAR <sup>™</sup>	PowerSaver <sup>™</sup>	SuperSOT <sup>™</sup> -6
ActiveArray <sup>™</sup>	FAST <sub>r</sub> <sup>™</sup>	LittleFET <sup>™</sup>	PowerTrench <sup>®</sup>	SuperSOT <sup>™</sup> -8
Bottomless <sup>™</sup>	FPS <sup>™</sup>	MICROCOUPLER <sup>™</sup>	QFET <sup>®</sup>	SyncFET <sup>™</sup>
Build it Now <sup>™</sup>	FRFET <sup>™</sup>	MicroFET <sup>™</sup>	QS <sup>™</sup>	TinyLogic <sup>®</sup>
CoolFET <sup>™</sup>	GlobalOptoisolator <sup>™</sup>	MicroPak <sup>™</sup>	QT Optoelectronics <sup>™</sup>	TINYOPTO <sup>™</sup>
CROSSVOLT <sup>™</sup>	GTO <sup>™</sup>	MICROWIRE <sup>™</sup>	Quiet Series <sup>™</sup>	TruTranslation <sup>™</sup>
DOE <sup>™</sup>	HiSeC <sup>™</sup>	MSX <sup>™</sup>	RapidConfigure <sup>™</sup>	UHC <sup>™</sup>
EcoSPARK <sup>™</sup>	I <sup>2</sup> C <sup>™</sup>	MSXPro <sup>™</sup>	RapidConnect <sup>™</sup>	UltraFET <sup>®</sup>
E <sup>2</sup> CMOS <sup>™</sup>	<i>i-Lo</i> <sup>™</sup>	OCX <sup>™</sup>	μSerDes <sup>™</sup>	UniFET <sup>™</sup>
EnSigna <sup>™</sup>	ImpliedDisconnect <sup>™</sup>	OCXPro <sup>™</sup>	ScalarPump <sup>™</sup>	VCX <sup>™</sup>
FACT <sup>™</sup>	IntelliMAX <sup>™</sup>	OPTOLOGIC <sup>®</sup>	SILENT SWITCHER <sup>®</sup>	Wire <sup>™</sup>
FACT Quiet Series <sup>™</sup>		OPTOPLANAR <sup>™</sup>	SMART START <sup>™</sup>	
Across the board. Around the world. <sup>™</sup>		PACMAN <sup>™</sup>	SPM <sup>™</sup>	
The Power Franchise <sup>®</sup>		POP <sup>™</sup>	Stealth <sup>™</sup>	
Programmable Active Droop <sup>™</sup>		Power247 <sup>™</sup>	SuperFET <sup>™</sup>	
		PowerEdge <sup>™</sup>	SuperSOT <sup>™</sup> -3	

**DISCLAIMER**

FAIRCHILD SEMICONDUCTOR RESERVES THE RIGHT TO MAKE CHANGES WITHOUT FURTHER NOTICE TO ANY PRODUCTS HEREIN TO IMPROVE RELIABILITY, FUNCTION OR DESIGN. FAIRCHILD DOES NOT ASSUME ANY LIABILITY ARISING OUT OF THE APPLICATION OR USE OF ANY PRODUCT OR CIRCUIT DESCRIBED HEREIN; NEITHER DOES IT CONVEY ANY LICENSE UNDER ITS PATENT RIGHTS, NOR THE RIGHTS OF OTHERS.

**LIFE SUPPORT POLICY**

FAIRCHILD'S PRODUCTS ARE NOT AUTHORIZED FOR USE AS CRITICAL COMPONENTS IN LIFE SUPPORT DEVICES OR SYSTEMS WITHOUT THE EXPRESS WRITTEN APPROVAL OF FAIRCHILD SEMICONDUCTOR CORPORATION. As used herein:

1. Life support devices or systems are devices or systems which, (a) are intended for surgical implant into the body, or (b) support or sustain life, or (c) whose failure to perform when properly used in accordance with instructions for use provided in the labeling, can be reasonably expected to result in significant injury to the user.
2. A critical component is any component of a life support device or system whose failure to perform can be reasonably expected to cause the failure of the life support device or system, or to affect its safety or effectiveness.

**PRODUCT STATUS DEFINITIONS****Definition of Terms**

Datasheet Identification	Product Status	Definition
Advance Information	Formative or In Design	This datasheet contains the design specifications for product development. Specifications may change in any manner without notice.
Preliminary	First Production	This datasheet contains preliminary data, and supplementary data will be published at a later date. Fairchild Semiconductor reserves the right to make changes at any time without notice in order to improve design.
No Identification Needed	Full Production	This datasheet contains final specifications. Fairchild Semiconductor reserves the right to make changes at any time without notice in order to improve design.
Obsolete	Not In Production	This datasheet contains specifications on a product that has been discontinued by Fairchild semiconductor. The datasheet is printed for reference information only.

Rev. 117