



FAN6520A

Single Synchronous Buck PWM Controller

Features

- Output Range: 0.8V to V_{IN}
 - 0.8V Internal Reference
 - $\pm 1.5\%$ Over Line Voltage and Temperature
- Drives N-Channel MOSFETs
- Simple Single-Loop Control Design
 - Voltage-Mode PWM Control
- Fast Transient Response
 - High-Bandwidth Error Amplifier
 - Full 0% to 100% Duty Cycle
- Lossless, Programmable, Over-Current Protection
 - Uses Upper MOSFET's $R_{DS(ON)}$
- Small Converter Size
 - 300kHz Fixed-Frequency Oscillator
 - Internal Soft-Start
 - 8-Lead SOIC

Applications

- Power Supplies for PC Subsystems and Peripherals
- MCH, GTL, and AGP Supplies
- Cable Modems, Set-Top Boxes, and DSL Modems
- DSP, Memory
- Low-Voltage Distributed Power Supplies

Description

The FAN6520A simplifies implementing a complete control and protection scheme for a DC-DC stepdown converter. Designed to drive N-channel MOSFETs in a synchronous buck topology, the FAN6520A integrates the control, output adjustment, monitoring, and protection functions into a single 8-lead package.

The FAN6520A employs a single feedback loop and voltage-mode control with fast transient response. The output voltage can be precisely regulated to as low as 0.8V, with a maximum tolerance of $\pm 1.5\%$ over-temperature and line-voltage variations. A fixed-frequency oscillator reduces design complexity, while balancing typical application cost. The error amplifier features a 15MHz gain-bandwidth product and an $8V/\mu s$ slew rate, which enables high converter bandwidth for fast transient performance. The resulting PWM duty cycles range from 0% to 100%.

The IC monitors the drop across the upper MOSFET and inhibits PWM operation appropriately to protect against over-current conditions. This approach simplifies the implementation and improves efficiency by eliminating the need for a current sense resistor.

The FAN6520A is rated for operation from 0° to $+70^\circ C$, with the FAN6520AI rated from -40° to $+85^\circ C$.

Ordering Information

Part Number	Temperature Range	Package	Packing
FAN6520AM	$0^\circ C$ to $70^\circ C$	SOIC-8	Rails
FAN6520AMX	$0^\circ C$ to $70^\circ C$	SOIC-8	Tape and Reel
FAN6520AIM	$-40^\circ C$ to $85^\circ C$	SOIC-8	Rails
FAN6520AIMX	$-40^\circ C$ to $85^\circ C$	SOIC-8	Tape and Reel

Pin Configuration

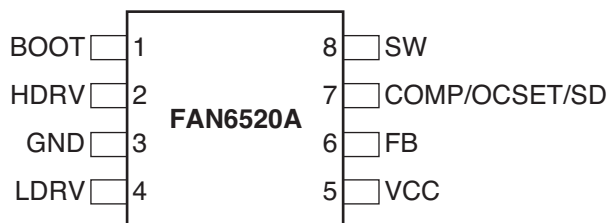

FAN6520AM 8-Pin SOIC Package

Pin Definitions

Pin #	Name	Description
1	BOOT	Bootstrap Supply Input. Provides a boosted voltage to the high-side MOSFET driver. Connect to bootstrap capacitor, as shown in Figure 1.
2	HDRV	High-Side Gate-Drive Output. Connect to the gate of the high-side power MOSFET(s). This pin is monitored by the adaptive shoot-through protection circuitry to determine when the upper MOSFET has turned off.
3	GND	Ground. The signal and power ground for the IC. Tie this pin to the ground island/plane through the lowest impedance connection available. Connect directly to source of low-side MOSFET(s).
4	LDRV	Low-Side Gate-Drive Output. Connect to the gate of the low-side power MOSFET(s). This pin is monitored by the adaptive shoot-through protection circuitry to determine when the lower MOSFET has turned off.
5	VCC	VCC. Provides bias power to the IC and the drive voltage for LDRV. Bypass with a ceramic capacitor as close to this pin as possible.
6	FB	Feedback. This pin is the inverting input of the internal error amplifier. Use this pin, in combination with the COMP/OCSET pin, to compensate the voltage-control feedback loop of the converter.
7	COMP/ OCSET/SD	Compensation / Over-Current Set Point / Shut Down. This is a multiplexed pin. During operation, the output of the error amplifier drives this pin. During a short period of time following power-on reset (POR), this pin is used to determine the over-current threshold of the converter. Pulling COMP/OCSET to a level below 0.8V disables the controller. Disabling the controller causes the oscillator to stop, the HDRV and LDRV outputs to be held low, and the soft-start circuitry to restart.
8	SW	Switch Node Input. The SW pin provides return for the high-side bootstrapped driver, is a sense point for the adaptive shoot-through protection, and is used to monitor the drop across the upper MOSFET's $R_{DS(ON)}$ for current limit. Connect as shown in Figure 1.

Typical Application

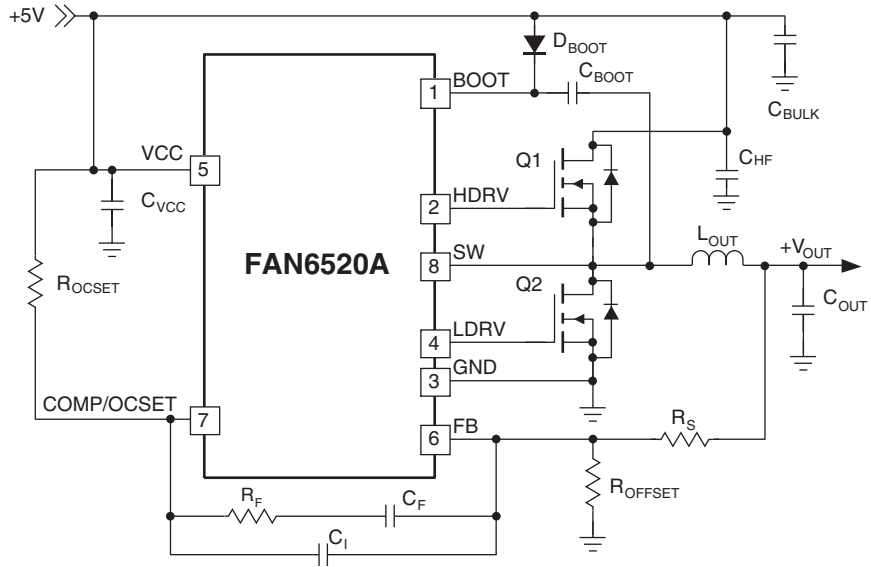

Figure 1. Typical Application

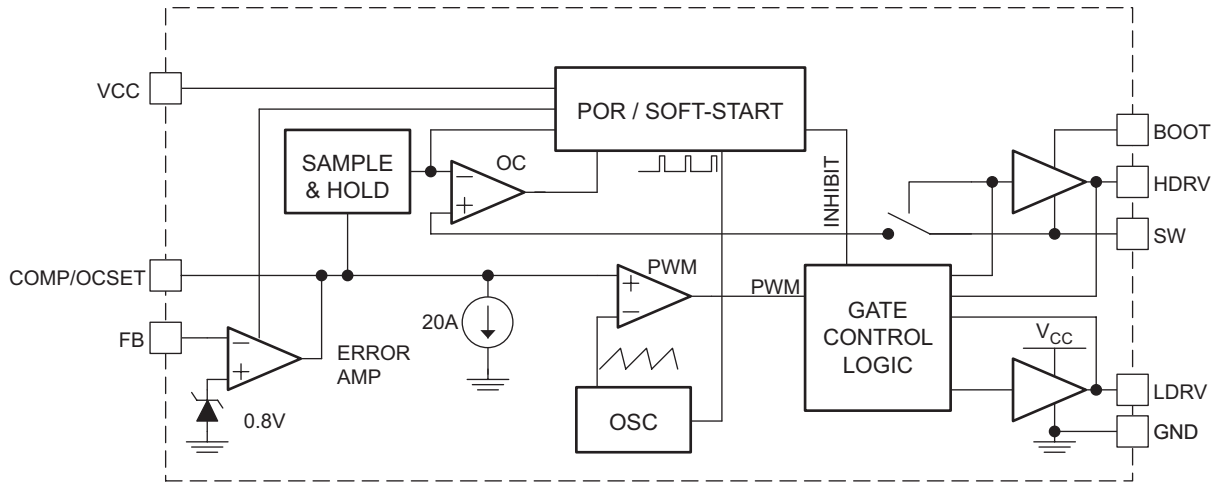

Figure 2. Functional Block Diagram

Absolute Maximum Ratings

The "Absolute Maximum Ratings" are those values beyond which the safety of the device cannot be guaranteed. The device should not be operated at these limits. The parametric values defined in the Electrical Characteristics tables are not guaranteed at the absolute maximum ratings. The "Recommended Operating Conditions" table defines the conditions for actual device operation.

Parameter	Min.	Max.	Units	
VCC to GND		6	V	
VBOOT to GND		15	V	
HDRV ($V_{BOOT} - V_{SW}$)		6	V	
LDRV	-0.5	6	V	
SW to PGND	Continuous	-0.5	6	V
	Transient ($t < 50\text{ns}$, $F < 500\text{kHz}$)	-3	7	V
All other pins		5.5	V	

Thermal Information

Symbol	Parameter	Min.	Typ.	Max.	Units
T_{STG}	Storage Temperature	-65		150	°C
T_L	Lead Soldering Temperature, 10 seconds			300	°C
	Vapor Phase, 60 seconds			215	°C
	Infrared, 15 seconds			220	°C
P_D	Power Dissipation, $T_A = 25^\circ\text{C}$			715	mW
θ_{JC}	Thermal Resistance, Junction-to-Case		40		°C/W
θ_{JA}	Thermal Resistance, Junction-to-Ambient		140		°C/W

Recommended Operating Conditions

Symbol	Parameter	Conditions	Min.	Typ.	Max.	Units
V_{CC}	Supply Voltage	VCC to PGND	4.5	5	5.5	V
T_A	Ambient Temperature	FAN6520A	0		70	°C
		FAN6520AI	-40		85	°C
T_J	Junction Temperature		-40		125	°C

Electrical Specifications

$V_{CC} = 5V$ and $T_A = 25^\circ C$, using the circuit shown in Figure 1 unless otherwise noted. The • denotes specifications that apply over the full operating temperature range.

Symbol	Parameter	Conditions		Min.	Typ.	Max.	Units
Supply Current							
I_{VCC}	V_{CC} Current	HDRV, LDRV open	•	1.5	2.4	3.8	mA
Power-On Reset							
POR	Rising VCC POR Threshold		•	4.00	4.22	4.45	V
	VCC POR Threshold Hysteresis				170		mV
Oscillator							
F_{OSC}	Frequency	FAN6520A	•	250	300	340	kHz
		FAN6520AI	•	230	300	340	kHz
ΔV_{OSC}	Ramp Amplitude		•		1.5		Vp-p
Reference							
V_{REF}	Reference Voltage	$T_A = 0$ to $70^\circ C$	•	788	800	812	mV
		FAN6520AI	•	780	800	820	mV
Error Amplifier							
	DC Gain				88		dB
GBWP	Gain – Bandwidth Product				15		MHz
S/R	Slew Rate				8		V/ μs
Gate Drivers							
R_{HUP}	HDRV Pull-Up Resistance				2.5		Ω
R_{HDN}	HDRV Pull-Down Resistance				2.0		Ω
R_{LUP}	LDRV Pull-Up Resistance				2.5		Ω
R_{LDN}	LDRV Pull-Down Resistance				1.0		Ω
Protection/Disable							
I_{OCSET}	OCSET Current Source	FAN6520A	•	17	20	22	μA
		FAN6520AI	•	14	20	24	μA
$V_{DISABLE}$	Disable Threshold				800		mV

Notes:

- All limits at operating temperature extremes are guaranteed by design, characterization, and statistical quality control.
- AC specifications guaranteed by design/characterization (not production tested).

Circuit Description

Initialization

The FAN6520A automatically initializes upon receipt of power. The Power-On Reset (POR) function continually monitors the bias voltage at the VCC pin. When the supply voltage exceeds its POR threshold, the IC initiates the Over-Current Protection (OCP) sample-and-hold operation. Upon completion of the OCP sample-and-hold operation, the POR function initiates soft-start operation.

Over-Current Protection

The over-current function protects the converter from a shorted output by using the upper MOSFET's on-resistance, $R_{DS(ON)}$, to monitor the current. This method enhances the converter's efficiency and reduces cost by eliminating the need for a current-sensing resistor. The over-current function cycles the soft-start function in a hiccup mode to provide fault protection. A resistor (R_{OCSET}) programs the over-current trip level (see Typical Application diagram). Immediately following POR, the FAN6520A initiates the Over-Current Protection sampling-and-hold operation. First, the internal error amplifier is disabled. This allows an internal $20\mu\text{A}$ current sink to develop a voltage across R_{OCSET} . The FAN6520A then samples this voltage at the COMP pin. This sampled voltage, which is referenced to the VCC pin, is held internally as the over-current set point. When the voltage across the upper MOSFET, which is also referenced to the VCC pin, exceeds the over-current set point, the over-current function initiates a soft-start sequence. Figure 3 shows the inductor current after a fault is introduced while running at 15A. The continuous fault causes the FAN6520A to go into a hiccup mode with a typical period of 25ms. The inductor current increases to 18A during the soft-start interval and causes an over-current trip. The converter dissipates very little power with this method. The measured input power for the conditions shown in Figure 3 is 1.5W.

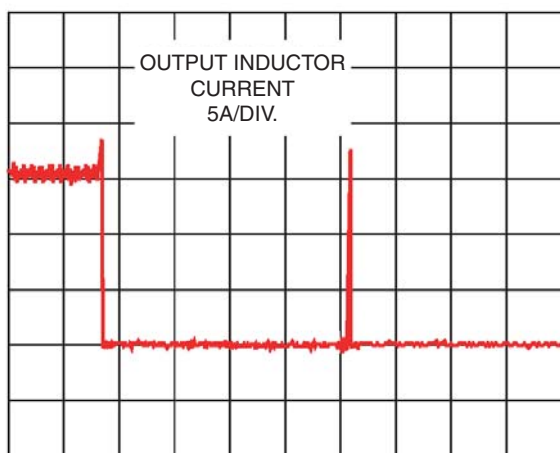

Figure 3. Over-Current Operation

The over-current function trips at a peak inductor current (I_{PEAK}) determined by:

$$I_{PEAK} = \frac{I_{OCSET} \times R_{OCSET}}{R_{DS(ON)}} \quad (1)$$

where I_{OCSET} is the internal OCSET current source ($20\mu\text{A}$ typical). The OC trip point varies mainly due to the MOSFET's $R_{DS(ON)}$ variations. To avoid over-current tripping in the normal operating load range, find the R_{OCSET} resistor from the equation above with:

- The maximum $R_{DS(ON)}$ at the highest junction temperature
- The minimum I_{OCSET} from the specification table
- Determine I_{PEAK} for $I_{PEAK} > I_{OUT(MAX)} + \frac{\Delta I}{2}$ where ΔI is the output inductor ripple current.

For an equation for the ripple current, see "Output Inductor (L_{out})" under Component Selection.

Internal circuitry of the FAN6520A does not recognize a voltage drop across R_{OCSET} larger than 0.5V. Any voltage drop across R_{OCSET} greater than 0.5V sets the over-current trip point to:

$$I_{PEAK} = \frac{0.5V}{R_{DS(ON)}} \quad (2)$$

An over-current trip cycles the soft-start function.

Soft-Start

The POR function initiates the soft-start sequence after the over-current set point has been sampled. Soft-start clamps the error amplifier output (COMP pin) and reference input (noninverting terminal of the error amp) to the internally generated soft-start voltage. Figure 4 shows a typical start-up interval where the COMP/OCSET pin has been released from a grounded (system shutdown) state. Initially, the COMP/OCSET is used to sample the over-current set point by disabling the error amplifier and drawing $20\mu\text{A}$ through R_{OCSET} . Once the over-current level has been sampled, the soft-start function is initiated. The clamp on the error amplifier (COMP/OCSET pin) initially controls the converter's output voltage during soft-start. The oscillator's triangular waveform is compared to the ramping error amplifier voltage. This generates SW pulses of increasing width that charge the output capacitor(s). When the internally generated soft-start voltage exceeds the feedback (FB pin) voltage, the output voltage is in regulation. This method provides a rapid and controlled output voltage rise. The entire start-up sequence typically takes about 11ms.

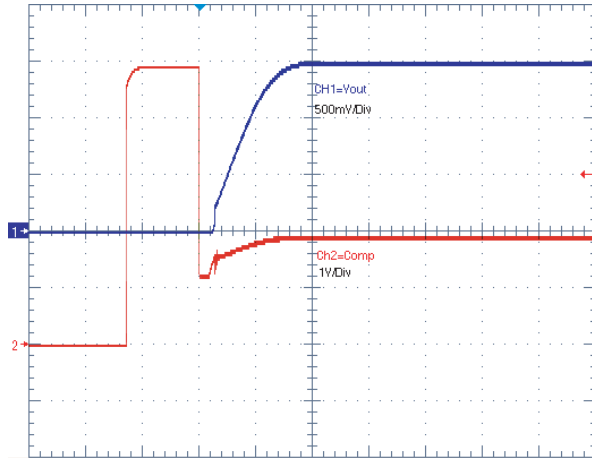

Figure 4. Soft-Start Interval

The FAN6520A incorporates a MOSFET shoot-through protection method that allows a converter to both sink and source current. Care should be exercised when designing a converter with the FAN6520A when it is known that the converter may sink current.

When the converter is sinking current, it is behaving as a boost converter regulating its input voltage. This means that the converter is boosting current into the V_{CC} rail, which supplies the bias voltage to the FAN6520A. If this current has nowhere to go—such as to other distributed loads on the V_{CC} rail, through a voltage limiting protection device, or other methods—the capacitance on the V_{CC} bus absorbs the current. This allows the voltage level of the V_{CC} rail to increase. If the voltage level of the rail is boosted to a level that exceeds the maximum voltage rating of the FAN6520A, the IC experiences an irreversible failure and the converter is no longer operational. Ensure that there is a path for the current to follow, other than the capacitance on the rail, to prevent this failure mode.

Application Information

Layout Considerations

In any high-frequency switching converter, layout is very important. Switching current from one power device to another can generate voltage transients across the impedances of the interconnecting bond wires and circuit traces. Use wide, short-printed traces to minimize interconnecting impedances. The critical components should be located as close together as possible, using ground plane construction or single-point grounding.

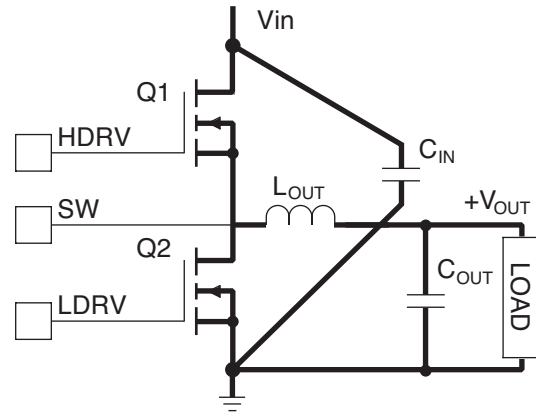

Figure 5. Printed Circuit Board Power and Ground Planes or Islands

Figure 5 shows the critical power components of the converter. To minimize voltage overshoot, the interconnecting wires (indicated by heavy lines) should be part of a ground or power plane in a printed circuit board. The components shown in Figure 5 should be located as close together as possible. Note that the capacitors C_{IN} and C_{OUT} may each represent numerous physical capacitors. Locate the FAN6520A within two inches of the Q1 and Q2 MOSFETs. The circuit traces for the MOSFETs' gate and source connections from the FAN6520A must be sized to handle up to 1A peak current.

Figure 5 shows the circuit traces that require additional layout consideration. Use single point and ground plane construction for the circuits shown. Minimize any leakage current paths on the COMP/OCSET pin and locate the resistor, R_{OSCSET} , close to the COMP/OCSET pin because the internal current source is only $20\mu A$. Provide local V_{CC} decoupling between the VCC and GND pins. Locate the capacitor, C_{BOOT} , as close as practical to the BOOT and PHASE pins. All components used for feedback compensation should be located as close to the IC as practical.

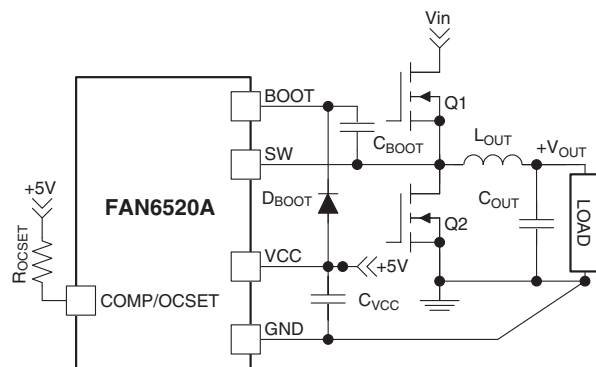

Figure 6. PCB Small Signal Layout Guidelines

Feedback Compensation

Figure 7 highlights the voltage-mode control loop for a synchronous-rectified buck converter. The output voltage (V_{OUT}) is regulated to the reference voltage level. The error amplifier (Error Amp) output ($V_{E/A}$) is compared with the oscillator (OSC) triangular wave to provide a pulse-width modulated (PWM) wave with an amplitude of V_{IN} at the SW node. The PWM wave is smoothed by the output LC filter (L_{OUT} and C_{OUT}).

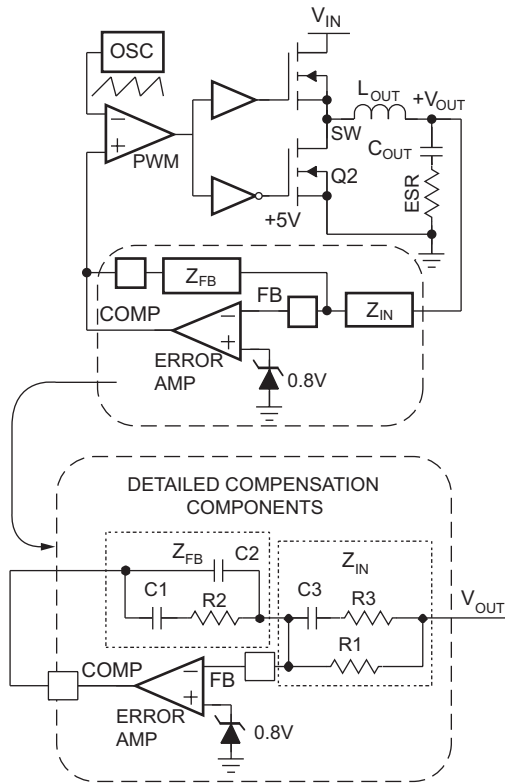

Figure 7. Voltage Mode Buck Converter Compensation Design

The modulator transfer function is the small-signal transfer function of V_{OUT}/V_{COMP} . This function is dominated by a DC gain and the output filter (L_{OUT} and C_{OUT}), with a double-pole break frequency at F_{LC} and a zero at F_{ESR} . The DC gain of the modulator is the input voltage (V_{IN}) divided by the peak-to-peak oscillator voltage (ΔV_{OSC} .)

The following equations define the modulator break frequencies as a function of the output LC filter:

$$F_{LC} = \frac{1}{2\pi\sqrt{L \times C}} \quad (3)$$

$$F_{ESR} = \frac{1}{2\pi \times ESR \times C} \quad (4)$$

The compensation network consists of the error amplifier (internal to the FAN6520A) and the impedance networks Z_{IN} and Z_{FB} . The goal of the compensation network is to provide a closed-loop transfer function with the highest 0dB crossing frequency (F_{0dB}) and adequate phase margin. Phase margin is the difference between the closed-loop phase at F_{0dB} and 180 degrees. The equations below relate the compensation network's poles, zeros, and gain to the components ($R1$, $R2$, $R3$, $C1$, $C2$, and $C3$), shown in Figure 7.

$$F_{Z1} = \frac{1}{2\pi R_2 C_1} \quad (5)$$

$$F_{P1} = \frac{1}{2\pi R_2 \left(\frac{C_1 C_2}{C_1 + C_2} \right)} \quad (6)$$

$$F_{Z2} = \frac{1}{2\pi C_3 (R_1 + R_3)} \quad (7)$$

$$F_{P2} = \frac{1}{2\pi R_3 C_3} \quad (8)$$

Use the following steps to locate the poles and zeros of the compensation network:

1. Pick gain ($R2/R1$) for the desired converter bandwidth.
2. Place the first zero below the filter's double pole ($\sim 75\% F_{LC}$).
3. Place the second zero at filter's double pole.
4. Place the first pole at the ESR zero.
5. Place the second pole at half the switching frequency.
6. Check the gain against the error amplifier's open-loop gain.
7. Estimate phase margin. Repeat if necessary.

Figure 8 shows an asymptotic plot of the DC-DC converter's gain vs. frequency. The actual modulator gain has a high gain peak due to the high Q factor of the output filter and is not shown in Figure 8. Using the above guidelines should give a compensation gain similar to the curve plotted. The open-loop error amplifier gain bounds the compensation gain. Check the compensation gain at $FP2$ with the capabilities of the error amplifier. The closed-loop gain is constructed on the graph of Figure 8 by adding the modulator gain (in dB) to the compensation gain (in dB). This is equivalent to multiplying the modulator transfer function by the compensation transfer function and plotting the gain.

The compensation gain uses external impedance networks Z_{FB} and Z_{IN} to provide a stable high bandwidth overall loop. A stable control loop has a gain crossing with a $-20dB/decade$ slope and a phase margin greater than 45° . Include worst-case component variations when determining phase margin.

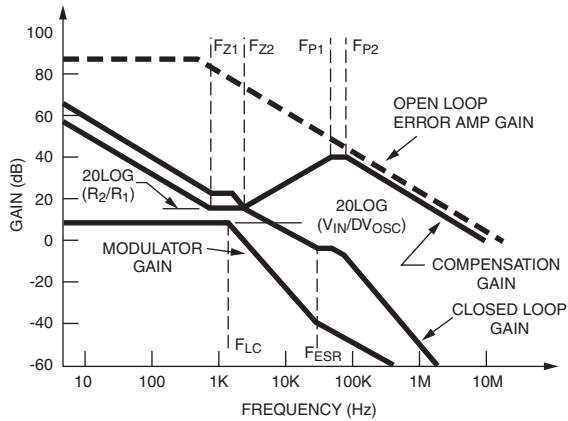

Figure 8. Asymptotic Bode Plot of Converter Gain

An output capacitor is required to filter the output and supply the load transient current. The filtering requirements are a function of the switching frequency and the ripple current. The load transient requirements are a function of the slew rate (di/dt) and the magnitude of the transient load current. These requirements are generally met with a mix of capacitors and careful layout.

Component Selection

Output Capacitors (C_{OUT})

Modern components and loads are capable of producing transient load rates above $1A/ns$. High-frequency capacitors initially supply the transient and slow the current load rate seen by the bulk capacitors. Effective Series Resistance (ESR) and voltage rating are typically the prime considerations for the bulk filter capacitors, rather than actual capacitance requirements. High-frequency decoupling capacitors should be placed as close to the power pins of the load as physically possible. Be careful not to add inductance in the circuit board wiring that could cancel the performance of these low-inductance components. Consult with the load manufacturer on specific decoupling requirements. Use only specialized low-ESR capacitors intended for switching-regulator applications for the bulk capacitors. The bulk capacitor's ESR determines the output ripple voltage and the initial voltage drop after a high slew-rate transient. An aluminum electrolytic capacitor's ESR value is related to the case size with lower ESR available in larger case sizes; however, the Equivalent Series Inductance (ESL) of these capacitors increases with case size and can reduce the usefulness of the capacitor to high slew-rate transient loading. Since ESL is not a specified parameter, work with the capacitor supplier and measure the capacitor's impedance with frequency to select a suitable component. Generally, multiple small-case electrolytic capacitors perform better than a single large-case capacitor.

Output Inductor (L_{OUT})

The output inductor is selected to meet the output voltage ripple requirements and minimize the converter's response time to the load transient. The inductor value determines the converter's ripple current and the ripple voltage is a function of the ripple current. The ripple voltage (ΔV) and current (ΔI) are approximated by the following equations:

$$\Delta I = \left(\frac{V_{IN} - V_{OUT}}{F_{SW} \times L} \right) \times \frac{V_{OUT}}{V_{IN}} \quad \Delta V \approx ESR \times \Delta I \quad (9)$$

Increasing the inductance value reduces the ripple current and voltage, but also reduces the converter's ability to quickly respond to a load transient. One of the parameters limiting the converter's response to a load transient is the time required to change the inductor current. Given a sufficiently fast control-loop design, the FAN6520A provides either 0% or 100% duty cycle in response to a load transient. The response time is the time required to slew the inductor current from an initial current value to the transient current level. During this interval, the difference between the inductor current and the transient current level must be supplied by the output capacitor. Minimizing the response time can minimize the output capacitance required.

Depending on whether there is a load application or a load removal, the response time to a load transient (I_{STEP}) is different. The following equations give the approximate response time interval for application and removal of a transient load:

$$T_{RISE} = \frac{L \times I_{STEP}}{V_{IN} - V_{OUT}} \quad (10)$$

$$T_{FALL} = \frac{L \times I_{STEP}}{V_{OUT}} \quad (11)$$

where T_{RISE} is the response time to the application of a positive I_{STEP} and T_{FALL} is the response time to a load removal (negative I_{STEP}). The worst-case response time can be either at application or removal of load. Check both of these equations at the minimum and maximum output levels for the worst-case response time.

Input Capacitor Selection

Use a mix of input bypass capacitors to control the voltage overshoot across the MOSFETs. Use small ceramic capacitors for high-frequency decoupling and bulk capacitors to supply the current needed each time Q1 turns on. Place the small ceramic capacitors physically close to the MOSFETs and between the drain of Q1 and the source of Q2. The important parameters for the bulk input capacitor are the voltage rating and the RMS current rating. For reliable operation, select the bulk capacitor with voltage and current ratings above the maximum input voltage and the largest RMS current required by the circuit. The capacitor voltage rating should be at least

1.25 times greater than the maximum input voltage. A voltage rating of 1.5 times is a conservative guideline.

The RMS current rating requirement (I_{RMS}) for the input capacitor of a buck regulator is:

$$I_{RMS} = I_L \sqrt{(D - D^2)} \quad (12)$$

where the converter duty cycle is $D = \frac{V_{OUT}}{V_{IN}}$.

For a through-hole design, several electrolytic capacitors may be needed. For surface-mount designs, solid tantalum capacitors can be used, but caution must be exercised with regard to the capacitor's surge current rating. The capacitors must be capable of handling the surge current at power-up. Some capacitor series available from reputable manufacturers are surge current tested.

Bootstrap Circuit

The bootstrap circuit uses a charge storage capacitor (C_{BOOT}) and the internal diode, as shown in Figure 1. Select these components after the high-side MOSFET has been chosen. The required capacitance is determined using the following equation:

$$C_{BOOT} = \frac{Q_G}{\Delta V_{BOOT}} \quad (13)$$

where Q_G is the total gate charge of the high-side MOSFET and ΔV_{BOOT} is the voltage droop allowed on the high-side MOSFET drive. To prevent loss of gate drive, the bootstrap capacitance should be at least 50 times greater than the C_{ISS} of Q1.

Thermal Considerations

Total device dissipation:

$$P_D = P_Q + P_{HDRV} + P_{LDRV} \quad (14)$$

where P_Q represents quiescent power dissipation.

$$P_Q = V_{CC} \times [4mA + 0.036 (F_{SW} - 100)] \quad (15)$$

where F_{SW} is switching frequency (in kHz).

P_{HDRV} represents internal power dissipation of the upper FET driver.

$$P_{HDRV} = P_{H(R)} \times P_{H(F)} \quad (16)$$

where $P_{H(R)}$ and $P_{H(F)}$ are internal dissipations for the rising and falling edges respectively.

$$P_{H(R)} = P_{Q1} \times \frac{R_{HUP}}{R_{HUP} + R_E + R_G} \quad (17)$$

$$P_{H(F)} = P_{Q1} \times \frac{R_{HDN}}{R_{HDN} + R_E + R_G} \quad (18)$$

where:

$$P_{Q1} = Q_{G1} \times V_{GS(Q1)} \times F_{SW} \quad (19)$$

where Q_{G1} is total gate charge of Q1 for its applied V_{GS} .

As described in the equations above, the total power consumed in driving the gate is divided in proportion to the resistances in series with the MOSFET's internal gate node, as shown in Figure 9.

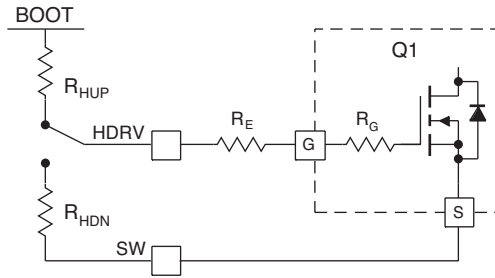

Figure 9. Driver Dissipation Model

R_G is the polysilicon gate resistance internal to the FET. R_E is the external gate drive resistor implemented in many designs. Note that the introduction of R_E can reduce driver power dissipation, but excess R_E may cause errors in the "adaptive gate drive" circuitry. For more information, please refer to Application Note AN-6003, "Shoot-through" in Synchronous Buck Converters at <http://www.fairchildsemi.com/an/AN/AN-6006.pdf>.

P_{LDRV} is dissipation of the lower FET driver.

$$P_{LDRV} = P_{L(R)} \times P_{L(F)} \quad (20)$$

where $P_{H(R)}$ and $P_{H(F)}$ are internal dissipations for the rising and falling edges, respectively:

$$P_{L(R)} = P_{Q2} \times \frac{R_{LUP}}{R_{LUP} + R_E + R_G} \quad (21)$$

$$P_{L(F)} = P_{Q2} \times \frac{R_{LDN}}{R_{LDN} + R_E + R_G} \quad (22)$$

where:

$$P_{Q2} = Q_{G2} \times V_{GS(Q2)} \times F_{SW}. \quad (23)$$

Power MOSFET Selection

For more information on MOSFET selection for synchronous buck regulators, refer to: AN-6005: Synchronous Buck MOSFET Loss Calculations at <http://www.fairchildsemi.com/an/AN/AN-6005.pdf>.

Losses in a MOSFET are the sum of its switching (P_{SW}) and conduction (P_{COND}) losses.

In typical applications, the FAN6520A converter's output voltage is low with respect to its input voltage; therefore the lower MOSFET (Q2) is conducting the full load current for most of the cycle. Choose a MOSFET for Q2 that has low $R_{DS(ON)}$ to minimize conduction losses.

In contrast, the high-side MOSFET (Q1) has a much shorter duty cycle and its conduction loss has less impact. Q1, however, sees most of the switching losses, so Q1's primary selection criteria should be gate charge.

High-Side Losses

Figure 10 shows a MOSFET's switching interval, with the upper graph being the voltage and current on the drain-to-source and the lower graph detailing V_{GS} vs. time with a constant current charging the gate. The x-axis, therefore, is also representative of gate charge (Q_G). $C_{ISS} = C_{GD} + C_{GS}$ and it controls t_1 , t_2 , and t_4 timing. C_{GD} receives the current from the gate driver during t_3 (as V_{DS} is falling). The gate charge (Q_G) parameters on the lower graph are either specified or can be derived from the MOSFET's datasheet.

Assuming switching losses are about the same for both the rising edge and falling edge, Q1's switching losses occur during the shaded time when the MOSFET has voltage across it and current through it.

These losses are given by:

$$P_{UPPER} = P_{SW} + P_{COND} \quad (24)$$

$$P_{SW} = \left(\frac{V_{DS} \times I_L}{2} \times 2 \times t_s \right) F_{SW} \quad (25)$$

$$P_{COND} = \left(\frac{V_{OUT}}{V_{IN}} \right) \times I_{OUT}^2 \times R_{DS(ON)} \quad (26)$$

where P_{UPPER} is the upper MOSFET's total losses, P_{SW} and P_{COND} are the switching and conduction losses for a given MOSFET, $R_{DS(ON)}$ is at the maximum junction temperature (T_J), and t_s is the switching period (rise or fall time) and is t_2+t_3 (Figure 10).

The driver's impedance and C_{ISS} determine t_2 , while t_3 's period is controlled by the driver's impedance and Q_{GD} . Since most of t_s occurs when $V_{GS} = V_{SP}$, use a constant current assumption for the driver to simplify the calculation of t_s :

$$t_s \approx \frac{Q_{G(SW)}}{I_{DRIVER}} \approx \frac{Q_{G(SW)}}{\left(\frac{V_{CC} - V_{SP}}{R_{DRIVER} + R_{GATE}} \right)} \quad (27)$$

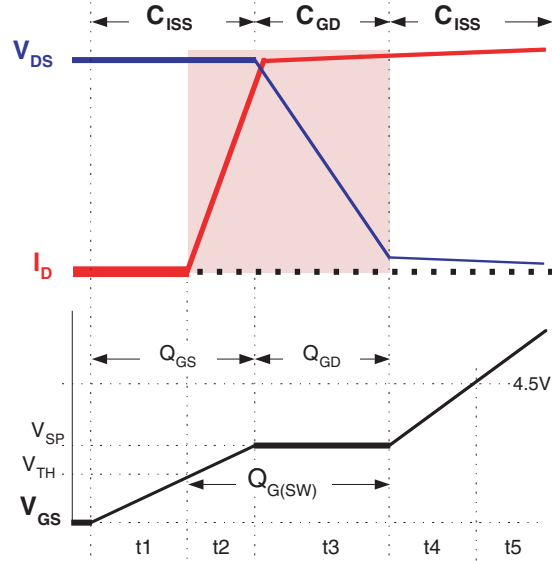

Figure 10. Switching Losses and Q_G

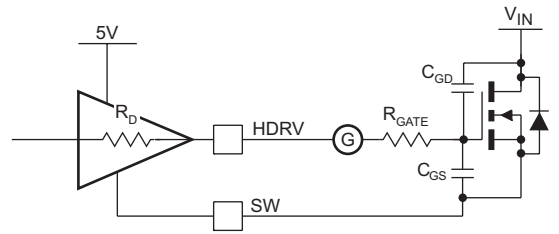

Figure 11. Drive Equivalent Circuit

Most MOSFET vendors specify Q_{GD} and Q_{GS} . $Q_{G(SW)}$ can be determined as $Q_{G(SW)} = Q_{GD} + Q_{GS} - Q_{TH}$ where Q_{TH} is the gate charge required to reach the MOSFET threshold (V_{TH}). For the high-side MOSFET, $V_{DS} = V_{IN}$, which can be as high as 20V in a typical portable application. Care should be taken to include the delivery of the MOSFET's gate power (P_{GATE}) in calculating the power dissipation required:

$$P_{GATE} = Q_G \times V_{CC} \times F_{SW} \quad (28)$$

where Q_G is the total gate charge to reach V_{CC} .

Low-Side Losses

Q2, however, switches on or off with its parallel Shottky diode conducting, therefore $V_{DS} \approx 0.5V$. Since P_{SW} is proportional to V_{DS} , Q2's switching losses are negligible and Q2 can be selected based on $R_{DS(ON)}$ only.

Conduction losses for Q2 are given by:

$$P_{COND} = (1-D) \times I_{OUT}^2 \times R_{DS(ON)} \quad (29)$$

where $R_{DS(ON)}$ is the $R_{DS(ON)}$ of the MOSFET at the highest operating junction temperature and

$D = \frac{V_{OUT}}{V_{IN}}$ is the minimum duty cycle for the converter.

Since $D_{MIN} < 20\%$ for portable computers, $(1-D) \approx 1$ produces a conservative result, simplifying the calculation.

The maximum power dissipation ($P_{D(MAX)}$) is a function of the maximum allowable die temperature of the low-

side MOSFET, the θ_{J-A} , and the maximum allowable ambient temperature rise:

$$P_{D(MAX)} = \frac{T_{J(MAX)} - T_{A(MAX)}}{\theta_{J-A}} \quad (30)$$

depends primarily on the amount of PCB area that can be devoted to heat sinking. Refer to Fairchild Application Note *AN-1029 Maximum Power Enhancement Techniques for SO-8 Power MOSFETs* at <http://www.fairchildsemi.com/an/AN/AN-1029.pdf>.

Typical Application Circuit

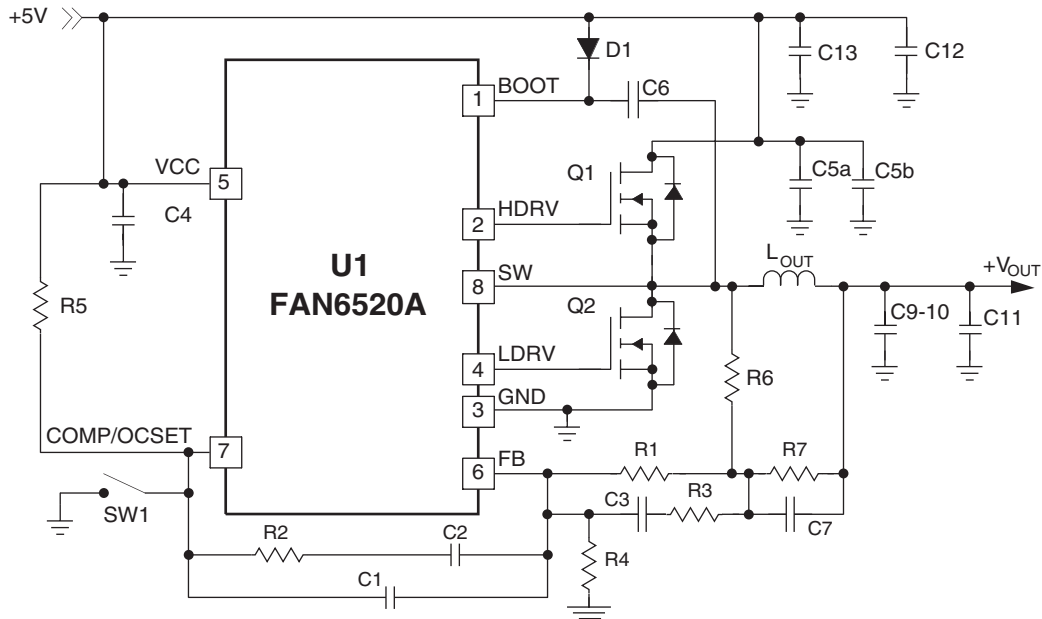
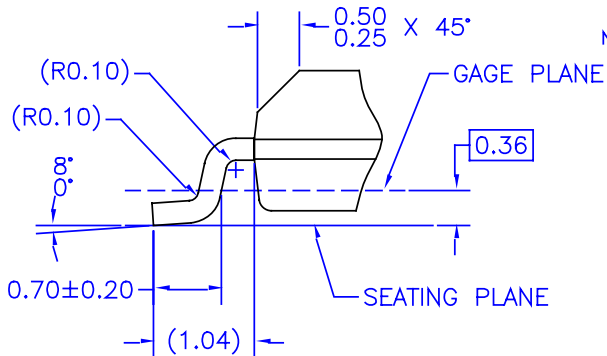
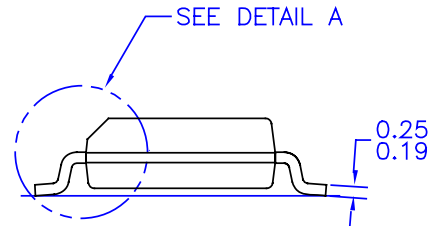
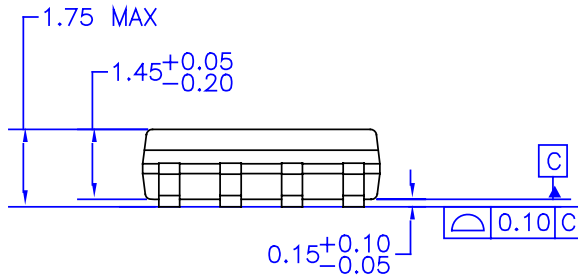
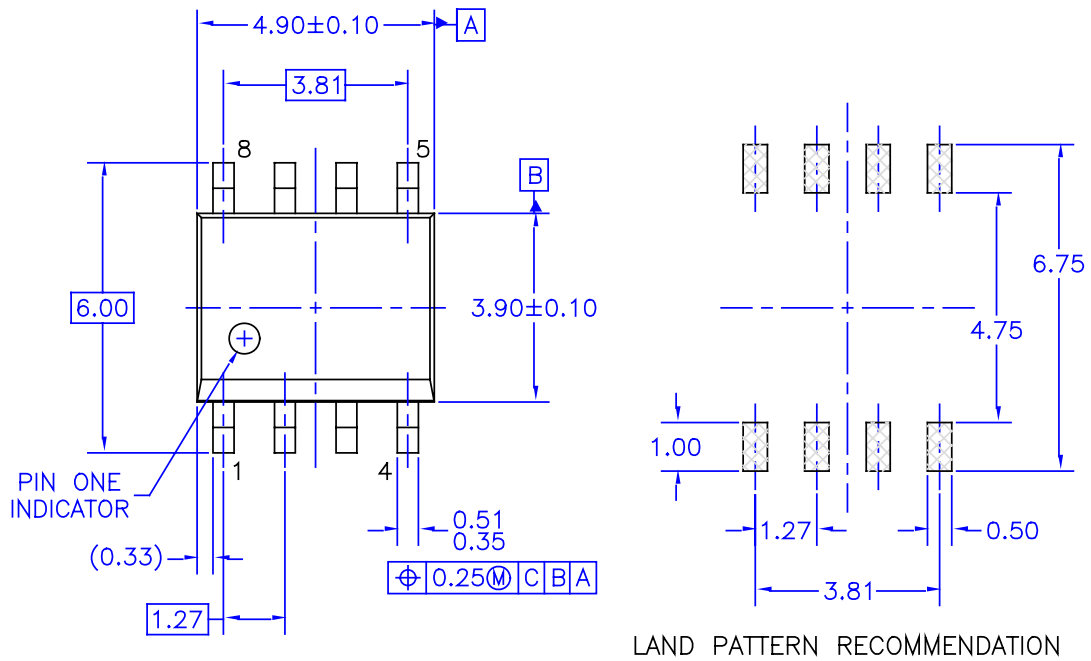

Figure 12. 5V to 1.5V 15A DC-DC Converter

Evaluation Board Bill of Materials (1.5V, 15 Amps):

Ref Des	Description	Manufacturer	P/N	Qty
C1	100pF Capacitor, 603	Any		1
C2	0.01 μ F Capacitor, 603	Any		1
C3	Not Populated			0
C4	0.1 μ F Capacitor, 603	Any		1
C5A,C5B	1 μ F Capacitor, 805	Any		3
C6,C11	0.1 μ F Capacitor, 603	Any		2
C7	Not Populated Capacitor, 603	Any		0
C9-10,C12,C13	1500 μ F Capacitor, 6.3V	United Chemi-con	KZJ6.3VB152M10X12LL	4
D1	Diode, 30mA, 30V	Fairchild	MMSD4148	1
L1	1.2 μ H Inductor	InterTechnical	SC5015-1R2M	1
Q1,Q2	MOSFET	Fairchild	FDD6606	2
R1	2.2k Ω 1% Resistor, 603	Any		1
R2	30.1k Ω 1% Resistor, 603	Any		1
R3	Not Populated			0
R4	2.49k Ω Resistor, 603	Any		1
R5	11.8k Ω Resistor, 603	Any		1
R6	Not Populated Resistor, 603	Any		0
R7	0 Ω Resistor, 603	Any		1
PB1	Pushbutton, miniature	Digikey	P8007S-ND	1
U1	Single Synchronous Buck PWM	Fairchild	FAN6520A	1
TP1,2,3,4	Test Points	KeyStone	1514-2	4

Dimensional Outline Drawing



NOTES: UNLESS OTHERWISE SPECIFIED

- A) THIS PACKAGE CONFORMS TO JEDEC MS-012, VARIATION AA, ISSUE C, DATED MAY 1990.
- B) ALL DIMENSIONS ARE IN MILLIMETERS.
- C) DIMENSIONS DO NOT INCLUDE MOLD FLASH OR BURRS.
- D) STANDARD LEAD FINISH: 200 MICRONS / 5.08 MICRONS MIN. LEAD/TIN (SOLDER) ON COPPER.

DETAIL A

SCALE: 2:1

M08AREVK

Figure 13. 8-Lead SOIC Package Drawing

TRADEMARKS

The following are registered and unregistered trademarks Fairchild Semiconductor owns or is authorized to use and is not intended to be an exhaustive list of all such trademarks.

ACE ^x ™	FACT Quiet Series™	OCX™	SILENT SWITCHER®	UniFET™
ActiveArray™	GlobalOptoisolator™	OCXPro™	SMART START™	UltraFET®
Bottomless™	GTO™	OPTOLOGIC®	SPM™	VCX™
Build it Now™	HiSeC™	OPTOPLANAR™	Stealth™	Wire™
CoolFET™	I ² C™	PACMAN™	SuperFET™	
CROSSVOLT™	i-Lo™	POP™	SuperSOT™-3	
DOME™	ImpliedDisconnect™	Power247™	SuperSOT™-6	
EcoSPARK™	IntelliMAX™	PowerEdge™	SuperSOT™-8	
E ² C MOS™	ISOPLANAR™	PowerSaver™	SyncFET™	
EnSigna™	LittleFET™	PowerTrench®	TCM™	
FACT™	MICROCOUPLER™	QFET®	TinyBoost™	
FAST®	MicroFET™	QS™	TinyBuck™	
FASTr™	MicroPak™	QT Optoelectronics™	TinyPWM™	
FPS™	MICROWIRE™	Quiet Series™	TinyPower™	
FRFET™	MSX™	RapidConfigure™	TinyLogic®	
	MSXPro™	RapidConnect™	TINYOPTO™	
Across the board. Around the world.™		μSerDes™	TruTranslation™	
The Power Franchise®		ScalarPump™	UHC™	
Programmable Active Droop™				

DISCLAIMER

FAIRCHILD SEMICONDUCTOR RESERVES THE RIGHT TO MAKE CHANGES WITHOUT FURTHER NOTICE TO ANY PRODUCTS HEREIN TO IMPROVE RELIABILITY, FUNCTION, OR DESIGN. FAIRCHILD DOES NOT ASSUME ANY LIABILITY ARISING OUT OF THE APPLICATION OR USE OF ANY PRODUCT OR CIRCUIT DESCRIBED HEREIN; NEITHER DOES IT CONVEY ANY LICENSE UNDER ITS PATENT RIGHTS, NOR THE RIGHTS OF OTHERS. THESE SPECIFICATIONS DO NOT EXPAND THE TERMS OF FAIRCHILD'S WORLDWIDE TERMS AND CONDITIONS, SPECIFICALLY THE WARRANTY THEREIN, WHICH COVERS THESE PRODUCTS.

LIFE SUPPORT POLICY

FAIRCHILD'S PRODUCTS ARE NOT AUTHORIZED FOR USE AS CRITICAL COMPONENTS IN LIFE SUPPORT DEVICES OR SYSTEMS WITHOUT THE EXPRESS WRITTEN APPROVAL OF FAIRCHILD SEMICONDUCTOR CORPORATION.

As used herein:

- Life support devices or systems are devices or systems which, (a) are intended for surgical implant into the body, or (b) support or sustain life, or (c) whose failure to perform when properly used in accordance with instructions for use provided in the labeling, can be reasonably expected to result in significant injury to the user.
- A critical component is any component of a life support device or system whose failure to perform can be reasonably expected to cause the failure of the life support device or system, or to affect its safety or effectiveness.

PRODUCT STATUS DEFINITIONS

Definition of Terms

Datasheet Identification	Product Status	Definition
Advance Information	Formative or In Design	This datasheet contains the design specifications for product development. Specifications may change in any manner without notice.
Preliminary	First Production	This datasheet contains preliminary data, and supplementary data will be published at a later date. Fairchild Semiconductor reserves the right to make changes at any time without notice to improve design.
No Identification Needed	Full Production	This datasheet contains final specifications. Fairchild Semiconductor reserves the right to make changes at any time without notice to improve design.
Obsolete	Not In Production	This datasheet contains specifications for a product that has been discontinued by Fairchild semiconductor. The datasheet is printed for reference information only.

Rev. I20