

FAN6791 / FAN6793

Highly Integrated, Dual-PWM Combination Controller

Features

- High-Voltage Startup
- Low Operating Current
- Interleaved Stand-by PWM / Forward PWM Switching
- Green Mode Stand-by PWM / Forward PWM
- Linearly Decreasing Stand-by PWM Frequency to 20kHz
- Remote On / Off
- AC Brownout Protection
- Forward PWM with Soft-Start
- Frequency Hopping to Reduce EMI Emissions
- Cycle-by-Cycle Current Limiting for Stand-by PWM / Forward PWM
- Leading-Edge Blanking for Stand-by PWM / Forward PWM
- Synchronized Slope Compensation for Stand-by PWM / Forward PWM
- GATE Output Maximum Voltage Clamp
- V_{DD} Over-Voltage Protection (OVP)
- V_{DD} Under-Voltage Lockout (UVLO)
- Internal Open-Loop Protection for Stand-by PWM / Forward PWM
- Constant Power Limit for Stand-by PWM / Forward PWM

Applications

General-purpose switch-mode power supplies and flyback power converters, including:

- PC-ATX Power Supplies

Description

The highly integrated FAN6791/3 dual PWM combination controller provides several features to enhance the performance of converters.

To minimize standby power consumption, a proprietary green-mode function provides off-time modulation to linearly decrease the switching frequency at light-load conditions. To avoid acoustic-noise problems, the minimum PWM frequency is set above 20kHz. This green-mode function enables the power supply to meet international power conservation requirements. With the internal high-voltage startup circuitry, the power loss due to bleeding resistors is also eliminated. To further reduce power consumption, FAN6791/3 is manufactured using the CMOS process, which allows an operating current of only 6mA.

FAN6791/3 integrates a frequency-jittering function internally to reduce EMI emissions of a power supply with minimum line filters. The built-in synchronized slope compensation achieves stable peak-current-mode control. The proprietary internal line compensation ensures constant output power limit.

FAN6791/3 provides many protection functions, including brownout protection, cycle-by-cycle current limiting, and an internal open-loop protection circuit to ensure safety should an open-loop or output short-circuit failure occur. PWM output is disabled until V_{DD} drops below the UVLO lower limit when the controller restarts. As long as V_{DD} exceeds ~24.5V, the internal OVP circuit is triggered.

Ordering Information

Part Number	OPWM Maximum Duty	Operating Temperature Range	Eco Status	Package	Packing Method
FAN6791NY	48%	-40°C to +105°C	Green	16-Pin Dual In-Line Package (DIP)	Tube
FAN6793NY	65%	-40°C to +105°C	Green	16-Pin Dual In-Line Package (DIP))	Tube
FAN6791MY	48%	-40°C to +105°C	Green	16-Pin Small Outline Integrated Circuit Package (SOIC)	Tape & Reel
FAN6793MY	65%	-40°C to +105°C	Green	16-Pin Small Outline Integrated Circuit Package (SOIC)	Tape & Reel

Application Diagram

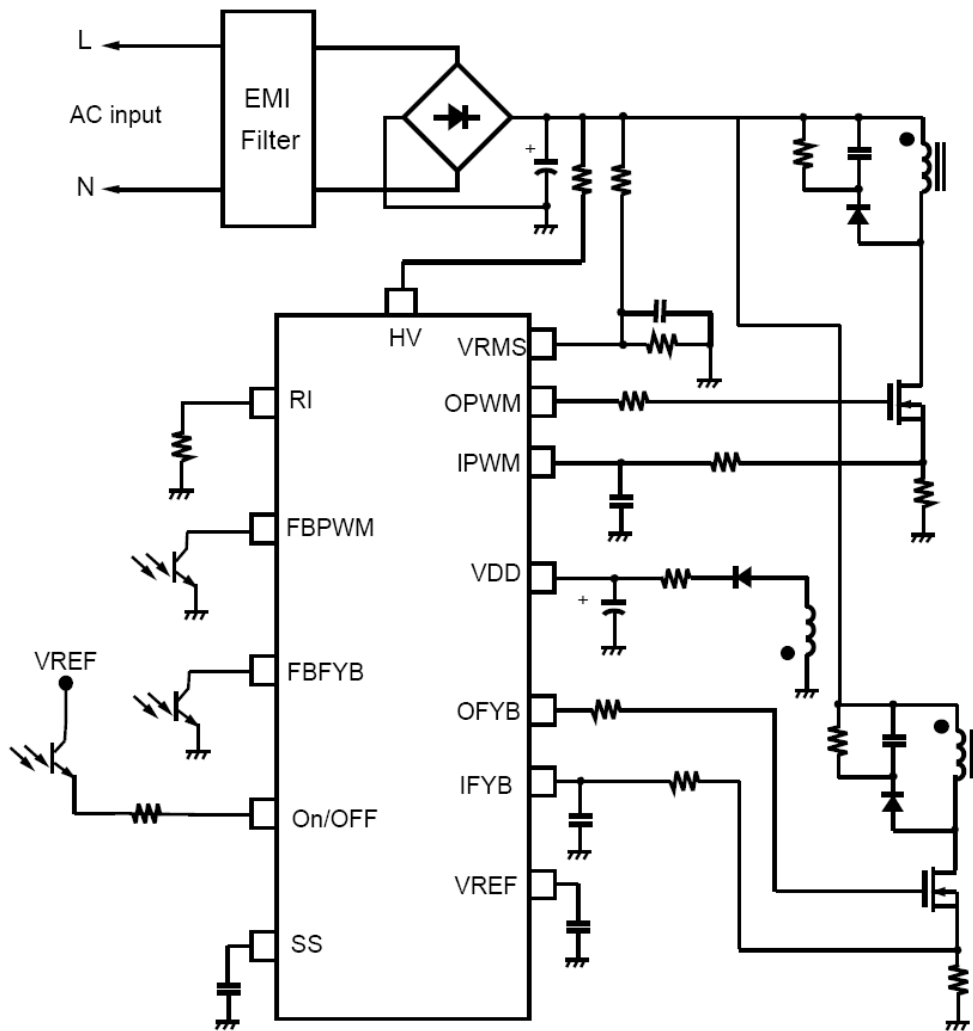

Figure 1. Typical Application

Block Diagram

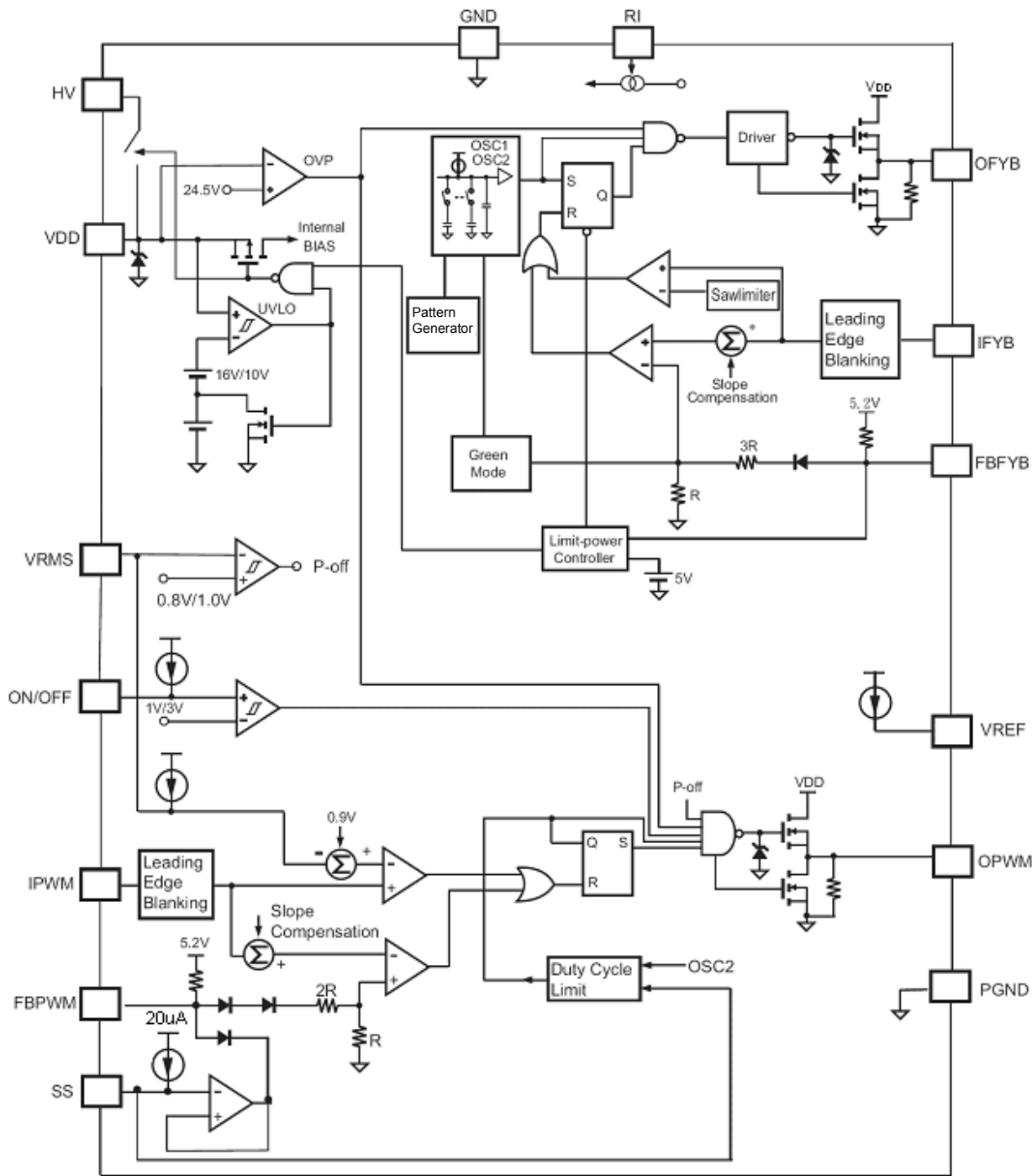

Figure 2. Function Block Diagram

Marking Information

SOIC



F – Fairchild Logo
Z – Plant Code
X – 1-Digit Year Code
Y – 1-Digit Week Code
TT – 2-Digit Die Run Code
T – Package Type (M:SOIC)
P – Y: Green Package
M – Manufacture Flow Code

DIP



F – Fairchild Logo
Z – Plant Code
X – 1-Digit year Code
YY – 2-Digit Week Code
TT – 2-Digit Die Run Code
T – Package Type (N:DIP)
P – Y: Green Package
M – Manufacture Flow Code

Figure 3. Top Mark

Pin Configuration

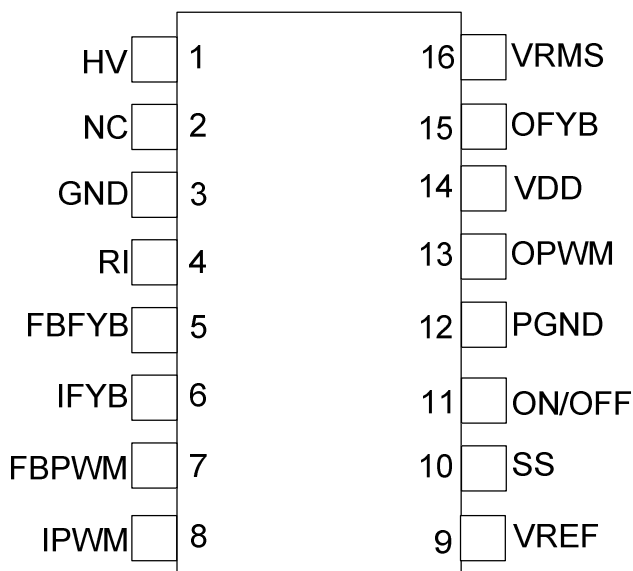

Figure 4. Pin Configuration (Top View)

Pin Definitions

Pin #	Name	Description
1	HV	For startup, this pin is pulled HIGH to the line input or bulk capacitor via resistors.
2	NC	No connection.
3	GND	Ground.
4	RI	Oscillator Setting. One resistor connected between RI and ground pins determines the switching frequency (resistance between 12 ~ 47k Ω is recommended). The switching frequency is equal to $[1560 / RI]kHz$, where RI is in k Ω . For example, if RI is equal to 24k Ω , then the switching frequency is 65kHz.
5	FBFYB	Voltage Feedback for Flyback PWM Stage. It is internally pulled HIGH through a 6.5k Ω resistor. An external opto-coupler from secondary feedback circuit is usually connected to this pin.
6	IFYB	PWM Current Sense for Flyback PWM Stage. The sensed voltage is used for peak-current-mode control and cycle-by-cycle current limiting.
7	FBPWM	Voltage Feedback for Forward PWM Stage. It is internally pulled HIGH through a 6.5k Ω resistor. An external opto-coupler from secondary feedback circuit is usually connected to this pin.
8	IPWM	PWM Current Sense for Forward PWM Stage. Via a current sense resistor, this pin provides the control input for peak-current-mode control and cycle-by-cycle current limiting.
9	VREF	Reference Voltage. This pin can provide a reference voltage 5V.
10	SS	PWM Soft-Start. During startup, the SS pin charges an external capacitor with a 20 μA constant current source. The voltage on FBPWM is clamped by SS during startup. In the event of a protection condition occurring and/or forward PWM being disabled, the SS pin quickly discharges.
11	ON/OFF	PWM Remote ON/OFF. Active HIGH. The forward PWM is disabled whenever the voltage at this pin is lower than 0.8V or the pin is open.
12	PGND	Ground. The power ground.
13	OPWM	Forward PWM Gate Drive. The totem-pole output drive for the forward PWM MOSFET. This pin is internally clamped under 16V to protect the MOSFET.
14	VDD	Power Supply. The internal protection circuit disables PWM output as long as V_{DD} exceeds the OVP trigger point.
15	OFYB	Flyback PWM Gate Drive. The totem-pole output drive for the forward PWM MOSFET. This pin is internally clamped under 16V to protect the MOSFET.
16	VRMS	Line-Voltage Detection. The pin is used for line compensation, for forward, and brownout protection.

Absolute Maximum Ratings

Stresses exceeding the absolute maximum ratings may damage the device. The device may not function or be operable above the recommended operating conditions and stressing the parts to these levels is not recommended. In addition, extended exposure to stresses above the recommended operating conditions may affect device reliability. The absolute maximum ratings are stress ratings only. All voltage values, except differential voltage, are given with respect to GND pin. Stresses beyond those listed under “absolute maximum ratings” may cause permanent damage to the device.

Symbol	Parameter		Min.	Max.	Unit
V _{DD}	DC Supply Voltage			27	V
V _{HV}	Input Voltage to HV Pin			500	V
V _{HIGH}	OPWM, OFYB, ON/OFF		-0.3	27.0	V
V _{LOW}	Others		-0.3	7.0	V
P _D	Power Dissipation (T _A < 50°C)			800	°C/W
T _J	Operating Junction Temperature		-40	+125	°C
T _{STG}	Storage Temperature Range		-55	+150	°C
R _{θja}	Thermal Resistance (Junction-to-Case)		DIP	82.5	°C/W
			SOIC	70.0	
T _L	Lead Temperature (Wave Soldering, 10 Seconds)			+260	°C
ESD	Electrostatic Discharge Capability	Human Body Model, JEDEC:JESD22-A114 (All Pins Except HV Pin)		3.5	kV
		Charged Device Model, JEDEC:JESD22-C101 (All Pins Except HV Pin)		1.5	

Recommended Operating Conditions

The Recommended Operating Conditions table defines the conditions for actual device operation. Recommended operating conditions are specified to ensure optimal performance to the datasheet specifications. Fairchild does not recommend exceeding them or designing to Absolute Maximum Ratings.

Symbol	Parameter	Min.	Max.	Unit
T _A	Operating Ambient Temperature	-40	+105	°C

Electrical Characteristics

$V_{DD}=18V$; $R_I=24k\Omega$; $T_A=25^\circ C$, unless noted.

Symbol	Parameter	Conditions	Min.	Typ.	Max.	Units
V_{DD} Section						
V_{DD-OP}	Continuously Operating Voltage				22	V
I_{DD-ST}	Startup Current	$V_{DD} - 0.16V$		10	50	μA
I_{DD-OP1}	Operating Current 1	$V_{DD}=15V$; GATE Open		6	10	mA
I_{DD-OP2}	Operating Current 2	$V_{DD}=15V$; GATE Open, $I_{REF}=10mA$		16	20	mA
V_{TH-ON}	Start Threshold Voltage		15	16	17	V
V_{TH-OFF}	Minimum Operating Voltage		9	10	11	V
V_{TH-OLP}	I_{DD-OLP} Off Voltage		6.5	7.5	8.0	V
I_{TH-OLP}	Internal Sink Current	$V_{TH-OLP} + 0.1V$	70	80	100	μA
V_{DD-OVP}	V_{DD} Over-Voltage Protection (Turn Off PWM with Delay)		23.4	24.5	25.5	V
t_{OVP}	V_{DD} Over-Voltage Protection Debounce	$V_{DD-OVP}=26V$	80	100	120	μs
HV						
I_D	Maximum Input Current	$V_{AC}=90V(V_{DC}=120V)$, $V_{DD}=10\mu F$	1.5	2.5	3.5	mA
I_{HV-CS}	Internal Current Source	$HV=500V$, $V_{DD}=15V$		10	50	μA
Oscillator and Green-Mode Operation						
V_{RI}	RI Voltage		1.176	1.200	1.224	V
f_{OSC}	Normal PWM Frequency	Center Frequency, $R_I=24k\Omega$	62	65	68	kHz
		Jitter Range	± 3.7	± 4.2	± 4.7	
$f_{OSC-G-MIN}$	Minimum Frequency in Green Mode	$R_I=24k\Omega$	18	20	22	kHz
RI	RI Range		12	24	47	k Ω
R_{IOPEN}	RI Pin Open Protection	If $R_I > R_{IOPEN}$, PWM Turned Off	1			M Ω
R_{ISHORT}	RI Pin Short Protection	If $R_I > R_{ISHORT}$, PWM Turned Off			6	k Ω
V_{RMS} for AC Brownout Protection						
$V_{RMS-OFF}$	Off Threshold Voltage for AC Brownout Protection		0.75	0.80	0.85	V
V_{RMS-ON}	Start Threshold Voltage for AC Brownout Protection		$V_{RMS-UVP-1}$ +0.17	$V_{RMS-UVP-1}$ +0.19	$V_{RMS-UVP-1}$ +0.21	V
t_{RMS}	AC Brownout Protection Debounce Time	$R_I=24k\Omega$	150	195	240	ms
VREF						
V_{REF}	Reference voltage	$I_{REF}=1mA$, $C_{REF}=0.1\mu F$	4.75	5.00	5.25	V
ΔV_{REF1}	Load Regulation of Reference Voltage	$C_{REF}=0.1\mu F$, $I_{REF}=1mA$ to 10mA			80	mV
ΔV_{REF2}	Line Regulation of Reference Voltage	$C_{REF}=0.1\mu F$, $V_{DD}=12V$ to 22V			25	mV
I_{REF_MAX}	Maximum Current		10		15	mA
I_{OS}	V_{REF} Short Current	$V_{DD}=15V$	15	20	25	mA

Electrical Characteristics

$V_{DD}=18V$; $R_i=24k\Omega$; $T_A=25^\circ C$, unless noted.

Symbol	Parameter	Conditions	Min.	Typ.	Max.	Units
ON/OFF						
$R_{ON/OFF}$	Impedance ON/OFF Pin		50		100	k Ω
V_{ON}	High Threshold Level of Synchronizing Signal		2.4	3.0	3.6	V
V_{OFF}	Low Threshold Level of Synchronizing Signal		0.8	1.0	1.2	V
Over Temperature Protection (OTP)						
T_{Off}	Protection Junction Temperature ⁽¹⁾		130	140	+150	$^\circ C$
$T_{Restart}$	Restart Junction Temperature ⁽²⁾		100	110	+120	$^\circ C$
Flyback PWM Stage						
FBFYB Feedback Input						
A_{V-FLY}	FB Input to Current Comparator Attenuation		1/3.75	1/3.20	1/2.75	V/V
Z_{FB}	Input Impedance		4	5	7	k Ω
V_{HGH}	Output High Voltage	FB Pin Open	5.0	5.2		V
V_{FB-OLP}	FB Open-Loop Trigger Level		4.2	4.5	4.8	V
t_{OLP}	FB Open-Loop Protection Delay		53	56	59	ms
V_N	Green Mode Entry FB Voltage		2.4	2.5	2.6	V
S_G	Slope of Green-Mode Modulation		60	75	90	Hz/mV
V_G	Green Mode Ending FB Voltage		1.8	1.9	2.0	V
$V_{OZ-OFYB}$	$V_{FBP_{PWM}}$ for Zero Duty Cycle(Forward Turn On)		1.2	1.3	1.4	V
IFYB Current Sense						
Z_{CS}	Input Impedance			12		k Ω
V_{LIMIT1}	Peak Current Limit Threshold Voltage 1	$V_{RMS}=1V$	0.75	0.80	0.85	V
V_{LIMIT2}	Peak Current Limit Threshold Voltage 2	$V_{RMS}=1.5V$		$V_{LIMIT1}-0.1$		V
t_{PD}	Propagation Delay to GATE Output	$V_{DD}=15V$, OFYB Drops to 9V	60		120	ns
t_{BNK}	Leading-Edge Blanking Time		200	270	350	ns
ΔV_{SLOPE}	Slope Compensation	Duty=DCY _{MAX}	0.34	0.37	0.41	V
V_{S-SCP}	Threshold Voltage for SENSE Short-Circuit Protection		0.1	0.15	0.2	V
t_{D-SSCP}	Delay Time for SENSE Short-Circuit Protection	$V_{SENSE}<0.15V$, $R_i=24K\Omega$	100	180	240	μs
OFYB-GATE Driver						
$V_{OFYB-CLAMP}$	Flyback PWM Gate Output Clamping Voltage	$V_{DD}=22V$		16	18	V
$V_{OL-OFYB}$	Output Voltage Low	$V_{DD}=15V$; $I_o=20mA$			1.5	V
$V_{OH-OFYB}$	Output Voltage High	$V_{DD}=12V$; $I_o=20mA$	8			V
t_{R-OFYB}	Rising Time	$V_{DD}=15V$; Gate=1nF; Gate=2~9V	30	60	120	ns
t_{F-OFYB}	Falling Time	$V_{DD}=15V$; Gate=1nF; Gate=9~2V	30	50	90	ns

Electrical Characteristics

$V_{DD}=18V$; $R_I=24k\Omega$; $T_A=25^\circ C$, unless noted.

Symbol	Parameter	Conditions	Min.	Typ.	Max.	Units
$DCY_{MAX-OFYB}$	Maximum Duty Cycle		60	65	70	%
Forward PWM Stage						
FBPWM-Feedback Input						
A_V	FB to Current Comparator Attenuation		1/3.2	1/2.7	1/2.2	V/V
Z_{FB}	Input Impedance		4	5	7	k Ω
V_{HGH}	Output High Voltage	FB Pin Open	5.0	5.2		V
$V_{OPEN-PWM}$	PWM Open-Loop Protection Voltage		4.2	4.5	4.8	V
$t_{OPEN-PWM-HICCUP}$	Interval of PWM Open-Loop Protection Reset	$R_I=24k\Omega$	500	600	700	ms
$t_{OPEN-PWM}$	PWM Open-Loop Protection Delay Time	$R_I=24k\Omega$	80	95	120	ms
$V_{OZ-OPWM}$	V_{FBPWM} for Zero Duty Cycle		1.2	1.3	1.4	V
IPWM-Current Sense						
t_{PD}	Propagation Delay to Output – V_{LIMIT} Loop	$V_{DD}=15V$, OPWM Drops to 9V	60		120	ns
V_{LIMIT1}	Peak Current Limit Threshold Voltage 1	$V_{RMS}=1V$	0.75	0.80	0.85	V
V_{LIMIT2}	Peak Current Limit Threshold Voltage 2	$V_{RMS}=1.5V$		$V_{LIMIT1}-0.1$		V
t_{BNK}	Leading-Edge Blanking Time		270	350	450	ns
ΔV_{SLOPE}	Slope Compensation $\Delta V_s = \Delta V_{SLOPE} \times (t_{on}/t)$ ΔV_s : Compensation Voltage Added to Current Sense		0.40	0.45	0.55	V
OPWM-GATE Driver						
$V_{OPWM-CLAMP}$	Output Voltage Maximum (Clamp)	$V_{DD}=22V$		16	18	V
V_{OL}	Output Voltage Low	$V_{DD}=15V$; $I_O=100mA$			1.5	V
V_{OH}	Output Voltage High	$V_{DD}=13V$; $I_O=100mA$	8			V
t_R	Rising Time	$V_{DD}=15V$; $C_L=5nF$; O/P=2V to 9V	30	60	120	ns
t_F	Falling Time	$V_{DD}=15V$; $C_L=5nF$; O/P=9V to 2V	30	50	110	ns
$DCY_{MAX-OPWM}$	FAN6791 Maximum Duty Cycle	$R_I=24k\Omega$	47	48	49	%
	FAN6793 Maximum Duty Cycle		60	65	70	
Soft Start						
I_{SS}	Constant Current Output for Soft-Start	$R_I=24k\Omega$	17	20	23	μA
R_D	Discharge Resistance			470	564	Ω

Notes:

- When activated, the output is disabled and the latch is turned off.
- This is the threshold temperature for enabling the output again and resetting the latch after over-temperature protection has been activated.

Typical Characteristics

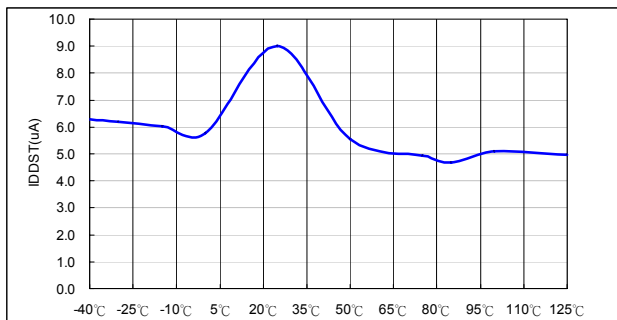

Figure 5. Startup Current I_{DD-ST} vs. Temperature

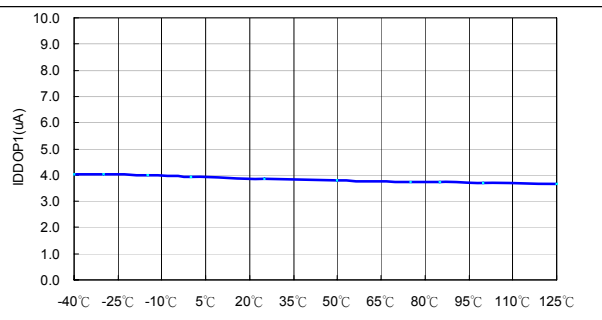

Figure 6. I_{DD-OP1} vs. Temperature

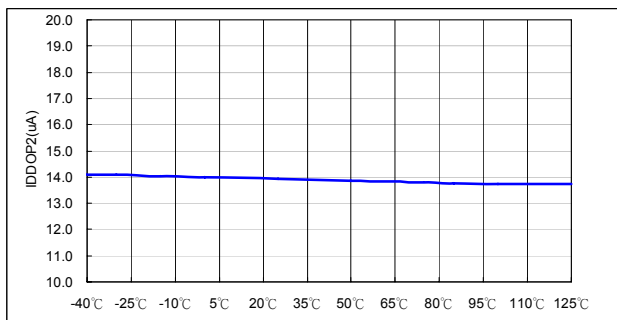

Figure 7. I_{DD-OP2} vs. Temperature

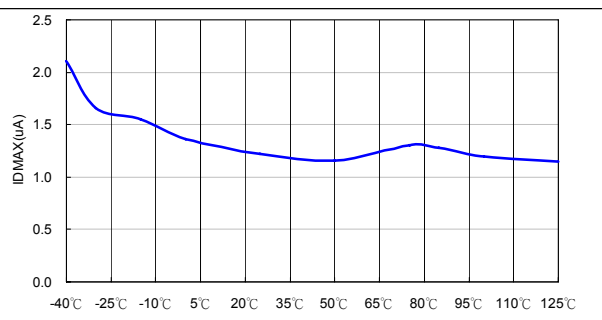

Figure 8. I_{D-MAX} vs. Temperature

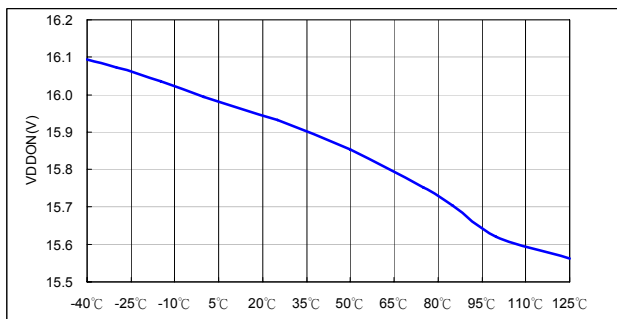

Figure 9. V_{DD-ON} vs. Temperature

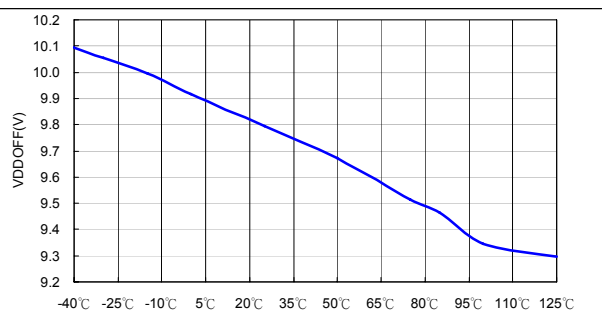

Figure 10. V_{DD-OFF} vs. Temperature

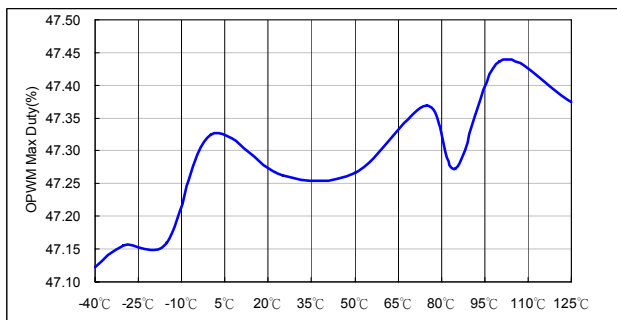

Figure 11. OPWM Maximum Duty Cycle vs. Temperature

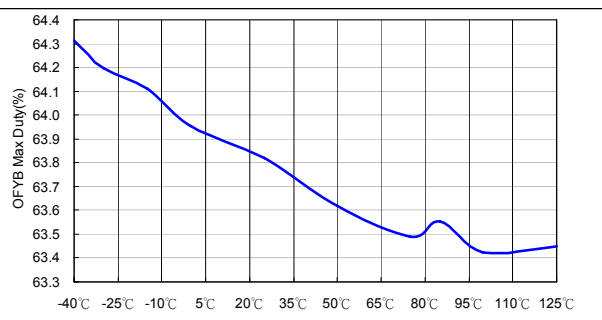

Figure 12. OFYB Maximum Duty Cycle vs. Temperature

Typical Characteristics

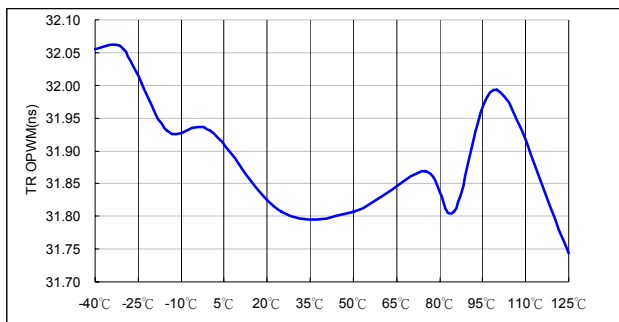

Figure 13. Rising Time t_{R-OPWM} vs. Temperature

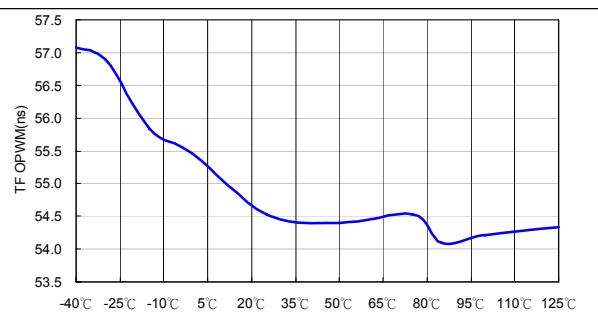

Figure 14. Falling Time t_{F-OPWM} vs. Temperature

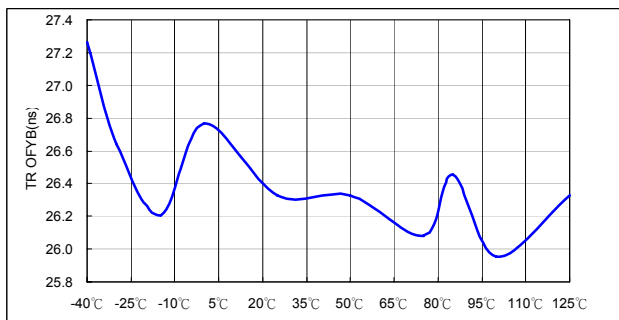

Figure 15. Rising Time t_{R-OFYB} vs. Temperature

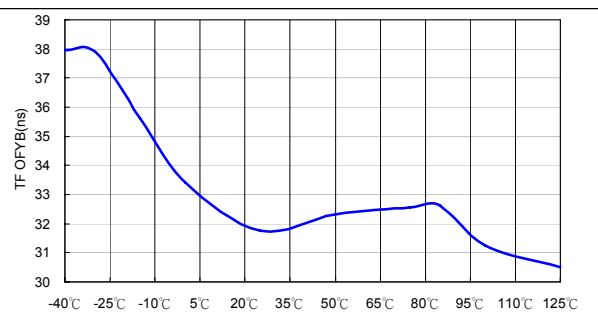

Figure 16. Falling Time t_{F-OFYB} vs. Temperature

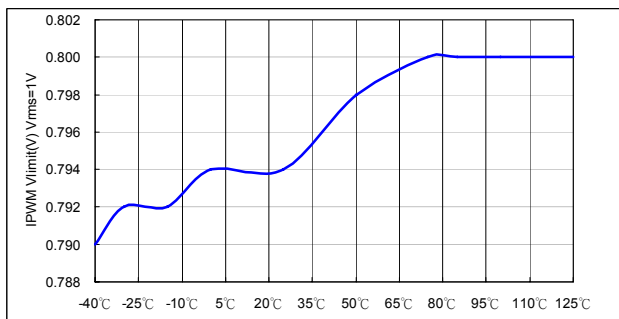

Figure 17. $I_{PWM-VLIMIT}$ ($V_{RMS}=1V$) vs. Temperature

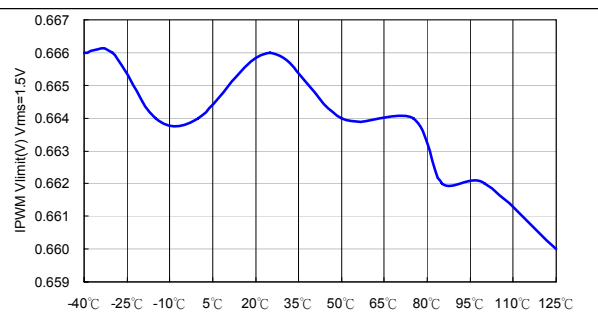

Figure 18. $I_{PWM-VLIMIT}$ ($V_{RMS}=1.5V$) vs. Temperature

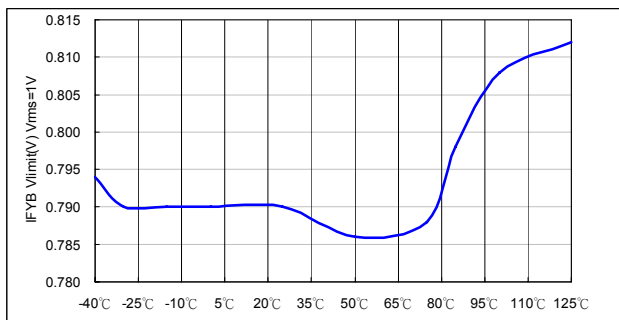

Figure 19. $I_{FYB-VLIMIT}$ ($V_{RMS}=1V$) vs. Temperature

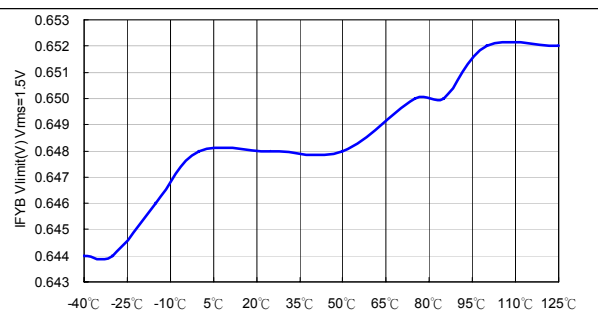

Figure 20. $I_{FYB-VLIMIT}$ ($V_{RMS}=1.5V$) vs. Temperature

Typical Characteristics

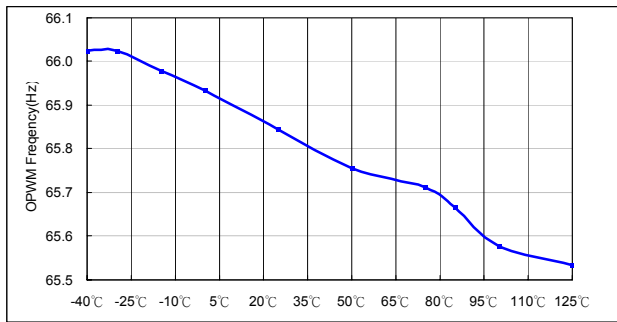

Figure 21. OPWM Frequency vs. Temperature

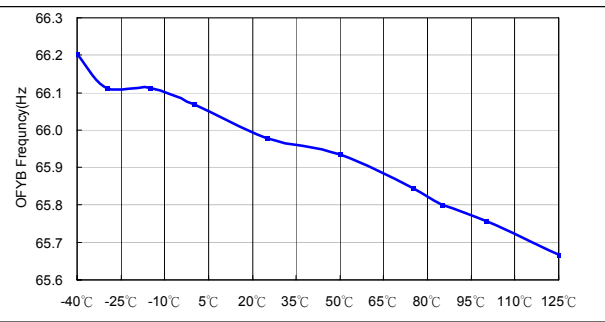

Figure 22. OFYB Frequency vs. Temperature

Functional Description

The highly integrated FAN6791/3 dual-PWM combination controller provides several features to enhance the performance of converters.

Proprietary interleave switching synchronizes the flyback and forward PWM stages. This reduces switching noise.

The proprietary frequency jittering function for the flyback and forward PWM stages helps reduce switching EMI emissions.

For the flyback and forward PWM, the synchronized slope compensation ensures the stability of the current loop under continuous-mode operation. In addition, FAN6791/3 provides complete protection functions, such as brownout protection and RI open/short.

Startup Current

For startup, the HV pin is connected to the line input or bulk capacitor through external resistor R_{HV} , recommended as 100k Ω . Typical startup current drawn from pin HV is 2mA and it charges the hold-up capacitor through the resistor R_{HV} . When the V_{DD} capacitor level reaches V_{DD-ON} , the startup current switches off. At this moment, the V_{DD} capacitor only supplies the FAN6791/3 to maintain the V_{DD} before the auxiliary winding of the main transformer provides the operating current.

Oscillator Operation

A resistor connected from the RI pin to the GND pin generates a constant current source for the FAN6791/3 controller. This current is used to determine the center PWM frequency. Increasing the resistance reduces PWM frequency. Using a 24k Ω resistor results in a corresponding 65kHz PWM frequency. The switching frequency is programmed by the resistor R_I connected between RI pin and GND. The relationship is:

$$f_{PWM} = \frac{1560}{R_I(k\Omega)} \text{ (kHz)} \quad (1)$$

The range of the PWM oscillation frequency is designed as 33kHz ~ 130kHz. FAN6791/3 integrates frequency hopping function internally. The frequency variation ranges from around 61kHz to 69kHz for a center frequency 65kHz. The frequency hopping function helps reduce EMI emission of a power supply with minimum line filters.

For power saving, flyback PWM stage has a green mode function. Frequency linearly decreases when V_{FB} is within V_G and V_N . Once V_{FB} is lower than V_G , switching frequency disables, and it enters burst mode.

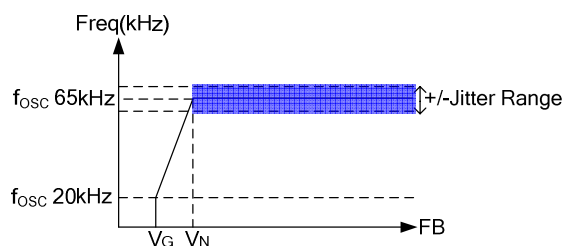

Figure 23. Oscillation Frequency in Green Mode

Line Voltage Detection (V_{RMS})

Figure 24 shows a resistive divider with low-pass filtering for line-voltage detection on V_{RMS} pin. The V_{RMS} voltage is used for high/low line compensation that keeps the constant power limit and provides brownout protection. For brownout protection, when the V_{RMS} voltage drops below 0.8V, OPWM turns off.

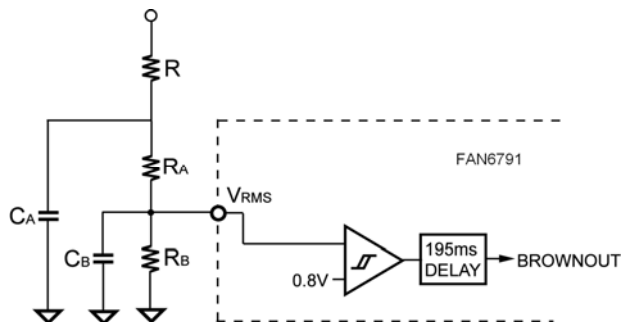

Figure 24. Line-Voltage Detection on V_{RMS} Pin

Remote On/Off

Figure 25 shows the remote on / off function. When the supervisor FPO pin pulls down and enables the system by connecting an opto-coupler, V_{REF} applies to the ON/OFF pin to enable forward PWM stage.

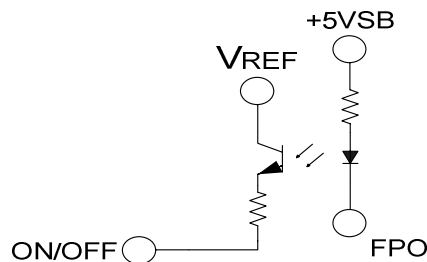

Figure 25. Remote On/Off

Interleave Switching

The FAN6791/3 uses interleaved switching to synchronize the stand-by PWM / forward PWM stages. This reduces switching noise and spreads the EMI emissions. Figure 26 shows that an off-time t_{OFF} is inserted in between the turn-off of the stand-by gate drives and the turn-on of the forward PWM.

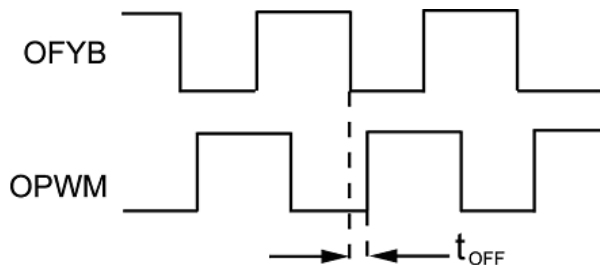

Figure 26. Interleaved Switching

Slope Compensation

The stand-by PWM and forward PWM stage are designed for flyback and forward power converters. Peak-current-mode control is used to optimize system performance. Slope compensation is added to stabilize the current loop. The FAN6791/3 inserts a synchronized, positively sloped ramp at each switching cycle. The positively sloped ramp is represented by the voltage signal V_{s-comp} in Figure 27.

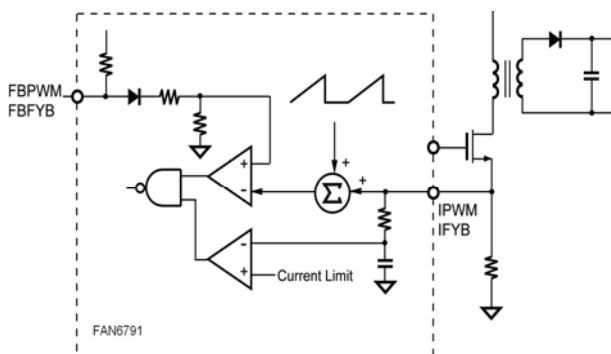

Figure 27. Slope Compensation

Gate Drivers

FAN6791/3 output stages are fast totem-pole gate drivers. The output driver is clamped by an internal 18V Zener diode to protect the power MOSFET.

Constant Power Control

To limit the output power of the converter constantly, a power-limit function is included. Sensing the converter input voltage through the VRMS pin, the power limit function generates a relative peak-current-limit threshold voltage for constant power control, as shown in Figure 28.

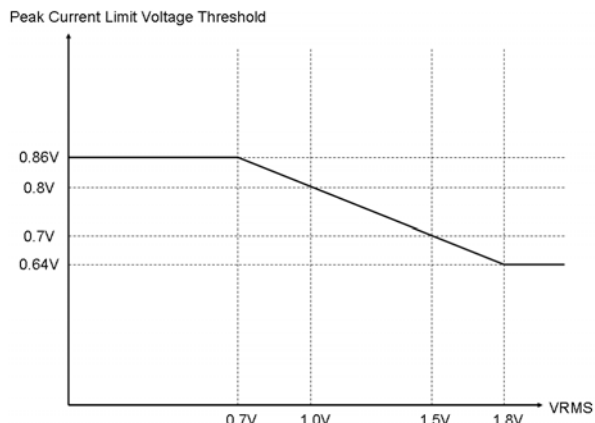

Figure 28. Constant Power Control

Protections

The FAN6791/3 provides full protection functions to prevent the power supply and the load from being damaged. The protection features include:

V_{DD} Over-Voltage Protection. The stand-by PWM and forward PWM stages will be disabled whenever the V_{DD} voltage exceeds the over-voltage threshold.

AC Under-Voltage Protection. The VRMS pin is used to detect the AC input voltage. When voltage is lower than the brownout threshold, voltage disables both forward and stand-by PWM.

RI Pin Open / Short Protection. The RI pin is used to set the switching frequency and internal current reference. The stand-by PWM and forward PWM stages are disabled whenever the RI pin is short or open.

Open-Loop Protection. The stand-by PWM and forward PWM stages of FAN6791/3 is disabled whenever the FBFYB / FBPWM pin is open.

Reference Circuit

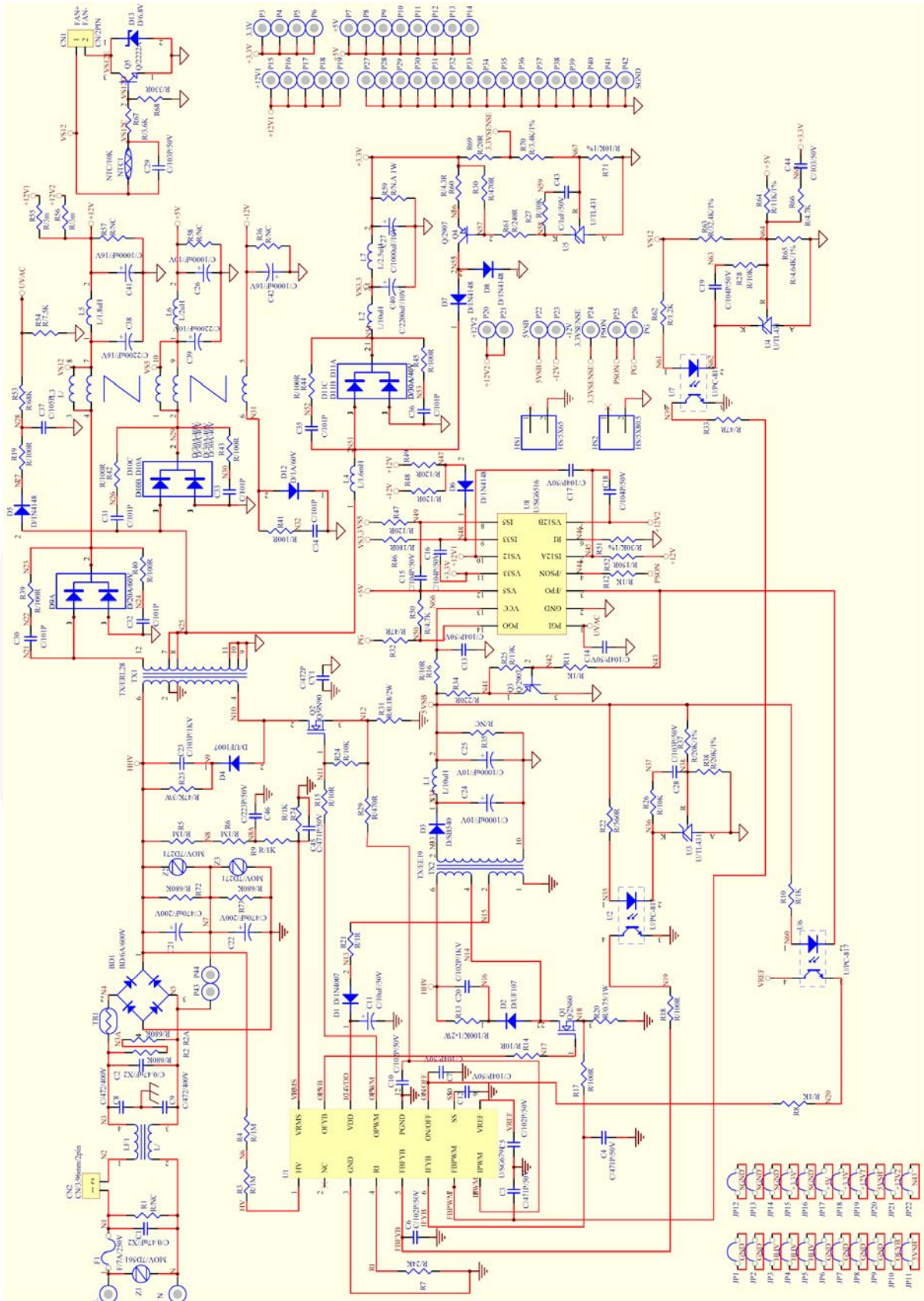
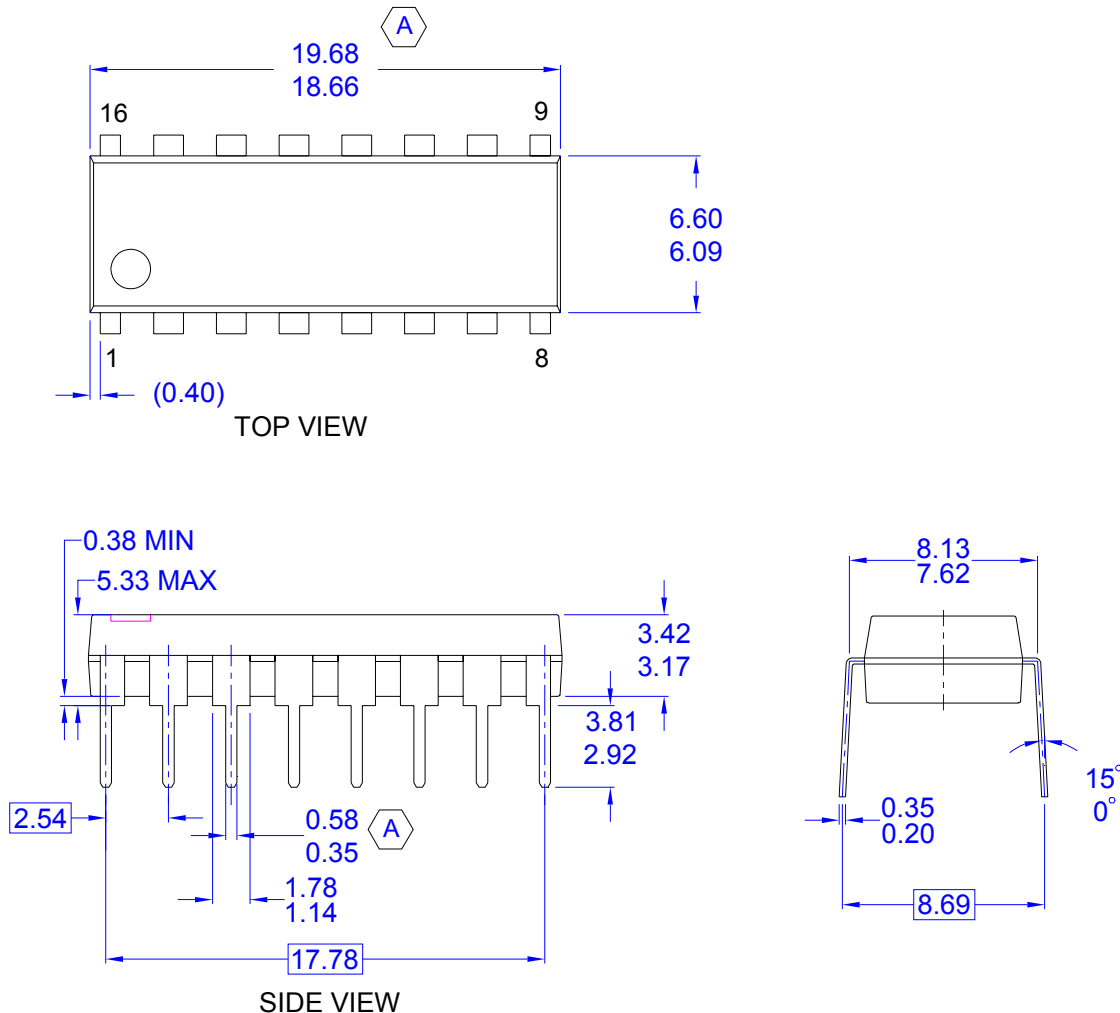

Figure 29. Reference Circuit

Build Of Materials List

Reference	Component	Reference	Component
C1	C/0.47 μ F/X2	R18	R/100 1/8W
C2	C/0.47 μ F/X2	R20	R/1/1W
C3	C/471P/50V	R21	R/1 1/8W
C4	C/471P/50V	R22	R/402 1/8W
C5	C/102P/50V	R23	R/47K 3W
C6	C/102P/50V	R24	R/10K 1/8W
C7	C/102P/50V	R26	R/2K 1/8W
C8	C/472/400V	R29	R/470 1/8W
C9	C/472/400V	R31	R/0.1/2W
C10	C/102P/50V	R35	R/N.A 1/4W
C11	C/10 μ F/50V	R37	R/20K 1% 1/8W
C12	C/104P/50V	R38	R/20K 1% 1/8W
C20	C/102P/1KV	Q1	2N/60
C21	C/470 μ F/200V	Q2	9N90
C22	C/470 μ F/200V	Z3	7D271
C23	C/103P/1KV	Z2	7D271
C24	C/1000 μ F/10V	Z1	7D561
C25	C/330 μ F/10V	D1	D/1N4007
C28	C/103P/50V	D2	D/UF107
R1	R/680K 1/4W NC	D3	D/SB540
R2	R/680K 1/4W	D4	D/UF1007
R3	R/51.1K 1/4W	BD1	D/6A/600V
R4	R/51.1K 1/4W	U1	SG6791/3
R5	R/2.4M 1/4W	U2	PC-817
R6	R/2.4M 1/4W	U3	TL431
R7	R/24K 1/8W	U6	PC-817
R8	R/1K 1/8W		
R9	R/19.1K 1/8W		
R10	R/1K 1/8W		
R13	R/100K 1/2W		
R14	R/10 1/8W		
R15	R/10 1/8W		
R17	R/100 1/8W		

Physical Dimension



NOTES: UNLESS OTHERWISE SPECIFIED

- A) THIS PACKAGE CONFORMS TO JEDEC MS-001 VARIATION BB
- B) ALL DIMENSIONS ARE IN MILLIMETERS.
- C) DIMENSIONS ARE EXCLUSIVE OF BURRS, MOLD FLASH, AND TIE BAR PROTRUSIONS
- D) CONFORMS TO ASME Y14.5M-1994
- E) DRAWING FILE NAME: N16EREV1

Figure 30. 16-Pin, Dual In-Line Package (DIP)

Package drawings are provided as a service to customers considering Fairchild components. Drawings may change in any manner without notice. Please note the revision and/or date on the drawing and contact a Fairchild Semiconductor representative to verify or obtain the most recent revision. Package specifications do not expand the terms of Fairchild's worldwide terms and conditions, specifically the warranty therein, which covers Fairchild products.

Physical Dimensions (Continued)

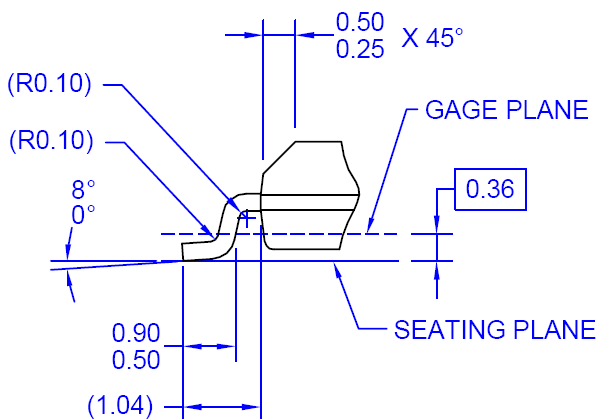
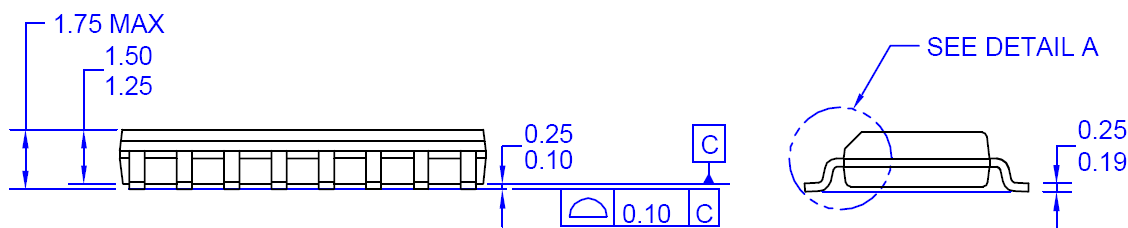
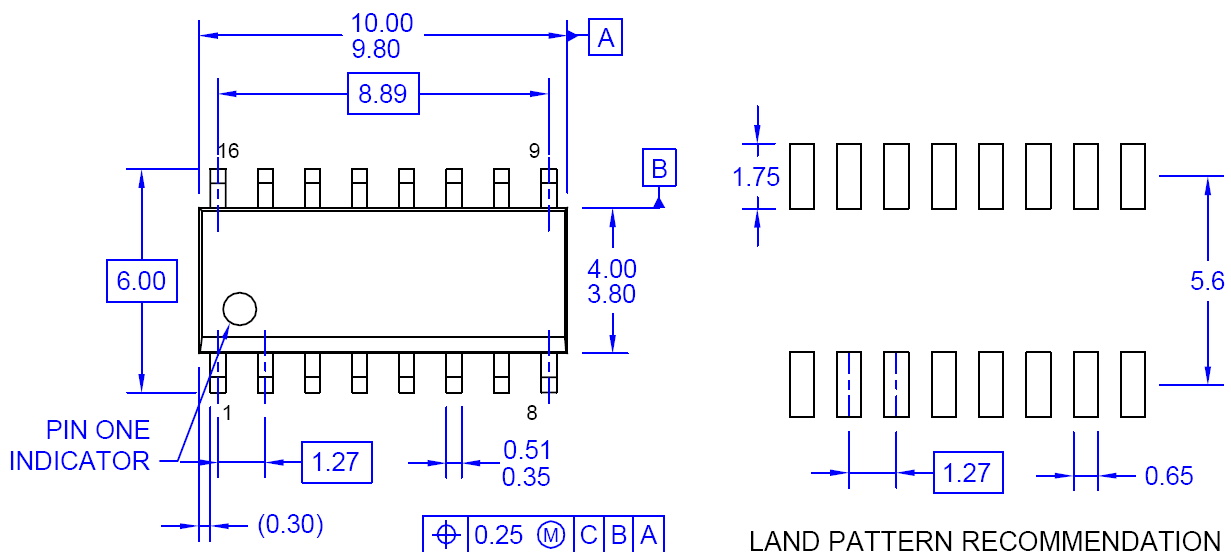

NOTES: UNLESS OTHERWISE SPECIFIED

- A) THIS PACKAGE CONFORMS TO JEDEC MS-012, VARIATION AC, ISSUE C.
- B) ALL DIMENSIONS ARE IN MILLIMETERS.
- C) DIMENSIONS ARE EXCLUSIVE OF BURRS, MOLD FLASH AND TIE BAR PROTRUSIONS
- D) CONFORMS TO ASME Y14.5M-1994
- E) LANDPATTERN STANDARD: SOIC127P600X175-16AM
- F) DRAWING FILE NAME: M16AREV12.

DETAIL A
SCALE: 2:1

Figure 31. 16-Pin, Small Outline Integrated Circuit (SOIC)

Package drawings are provided as a service to customers considering Fairchild components. Drawings may change in any manner without notice. Please note the revision and/or date on the drawing and contact a Fairchild Semiconductor representative to verify or obtain the most recent revision. Package specifications do not expand the terms of Fairchild's worldwide terms and conditions, specifically the warranty therein, which covers Fairchild products.

ON Semiconductor and  are trademarks of Semiconductor Components Industries, LLC dba ON Semiconductor or its subsidiaries in the United States and/or other countries. ON Semiconductor owns the rights to a number of patents, trademarks, copyrights, trade secrets, and other intellectual property. A listing of ON Semiconductor's product/patent coverage may be accessed at www.onsemi.com/site/pdf/Patent-Marking.pdf. ON Semiconductor reserves the right to make changes without further notice to any products herein. ON Semiconductor makes no warranty, representation or guarantee regarding the suitability of its products for any particular purpose, nor does ON Semiconductor assume any liability arising out of the application or use of any product or circuit, and specifically disclaims any and all liability, including without limitation special, consequential or incidental damages. Buyer is responsible for its products and applications using ON Semiconductor products, including compliance with all laws, regulations and safety requirements or standards, regardless of any support or applications information provided by ON Semiconductor. "Typical" parameters which may be provided in ON Semiconductor data sheets and/or specifications can and do vary in different applications and actual performance may vary over time. All operating parameters, including "Typicals" must be validated for each customer application by customer's technical experts. ON Semiconductor does not convey any license under its patent rights nor the rights of others. ON Semiconductor products are not designed, intended, or authorized for use as a critical component in life support systems or any FDA Class 3 medical devices or medical devices with a same or similar classification in a foreign jurisdiction or any devices intended for implantation in the human body. Should Buyer purchase or use ON Semiconductor products for any such unintended or unauthorized application, Buyer shall indemnify and hold ON Semiconductor and its officers, employees, subsidiaries, affiliates, and distributors harmless against all claims, costs, damages, and expenses, and reasonable attorney fees arising out of, directly or indirectly, any claim of personal injury or death associated with such unintended or unauthorized use, even if such claim alleges that ON Semiconductor was negligent regarding the design or manufacture of the part. ON Semiconductor is an Equal Opportunity/Affirmative Action Employer. This literature is subject to all applicable copyright laws and is not for resale in any manner.

PUBLICATION ORDERING INFORMATION

LITERATURE FULFILLMENT:

Email Requests to: orderlit@onsemi.com

ON Semiconductor Website: www.onsemi.com

TECHNICAL SUPPORT

North American Technical Support:
Voice Mail: 1 800-282-9855 Toll Free USA/Canada
Phone: 011 421 33 790 2910

Europe, Middle East and Africa Technical Support:

Phone: 00421 33 790 2910

For additional information, please contact your local Sales Representative