

FAN73711

High-Current, High-Side Gate Drive IC

Features

- Floating Channel for Bootstrap Operation to +600 V
- 4 A / 4 A Sourcing/Sinking Current Driving Capability
- Common-Mode dv/dt Noise Canceling Circuit
- 3.3 V and 5 V Input Logic Compatible
- Output In-phase with Input Signal
- Under-Voltage Lockout for V_{BS}
- Built-In Shunt Regulator on V_{DD} and V_{BS}
- 8-Lead, Small Outline Package (SOP)

Applications

- High-Speed Gate Driver
- Sustain Switch Driver in PDP Application
- Energy Recovery Circuit Switch Driver in PDP Application
- High-Power Buck Converter
- Motor Drive Inverter

Description

The FAN73711 is a monolithic high-side gate-drive IC that can drive high-speed MOSFETs and IGBTs operating up to +600 V. It has a buffered output stage with all NMOS transistors designed for high pulse-current driving capability and minimum cross-conduction.

Fairchild's high-voltage process and common-mode noise canceling techniques provide stable operation of the high-side driver under high dv/dt noise circumstances. An advanced level-shift circuit offers high-side gate driver operation up to $V_S = -9.8$ V (typical) for $V_{BS} = 15$ V. The UVLO circuit prevents malfunction when V_{BS} is lower than the specified threshold voltage.

The high-current and low-output voltage-drop feature makes this device suitable as a sustain and energy-recovery circuit switch driver in plasma display panel, motor drive inverter, switching power supply, and high-power DC-DC converter applications.

8-SOP



Ordering Information

| Part Number | Operating Temperature Range | Package | Packing Method |
|-------------|-----------------------------|---------|----------------|
| FAN73711MX | 40°C ~ 125°C | 8-SOP | Tape and Reel |

Typical Application Diagrams

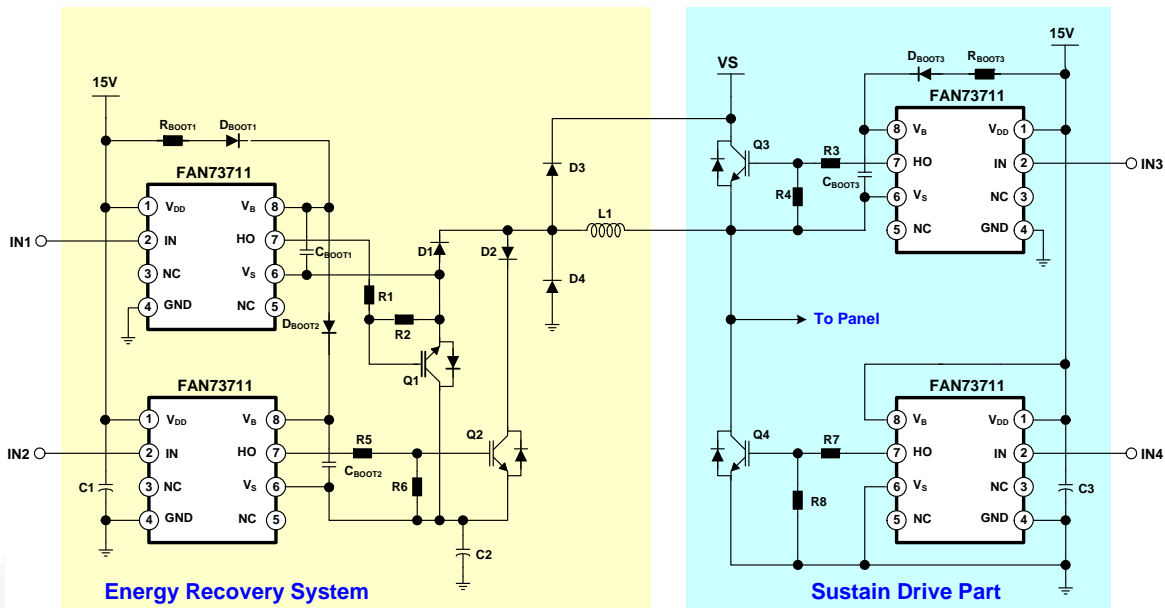

FAN73711 Rev.01

Figure 1. Floated Bi-Directional Switch and Half-Bridge Driver: PDP Application

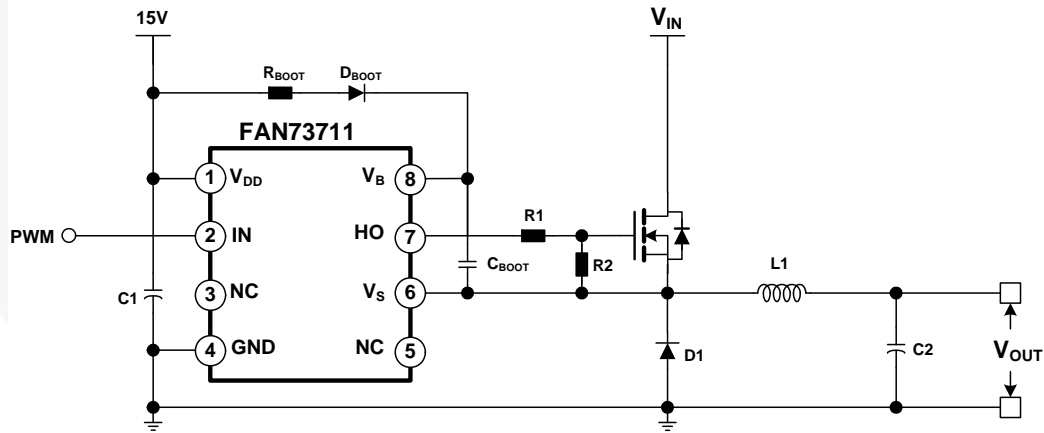

FAN73711 Rev.01

Figure 2. Step-Down (Buck) DC-DC Converter Application

Internal Block Diagram

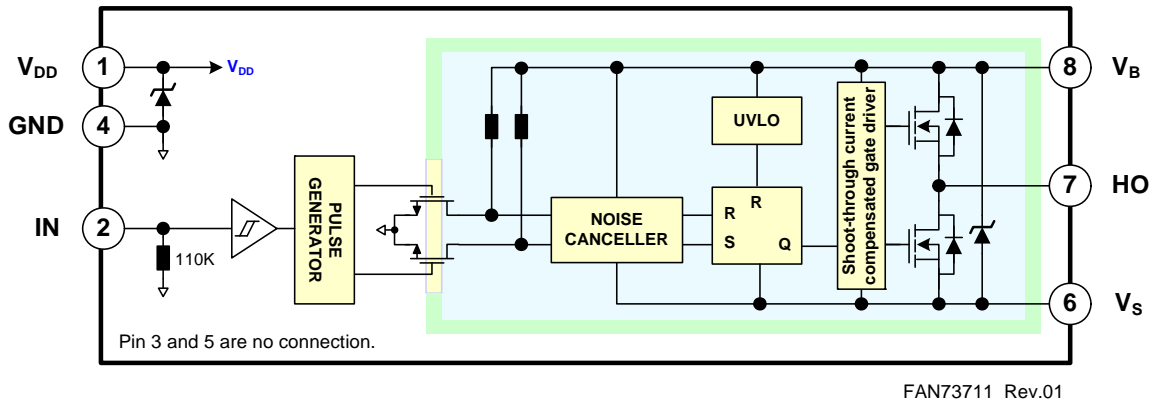

Figure 3. Functional Block Diagram

Pin Configuration

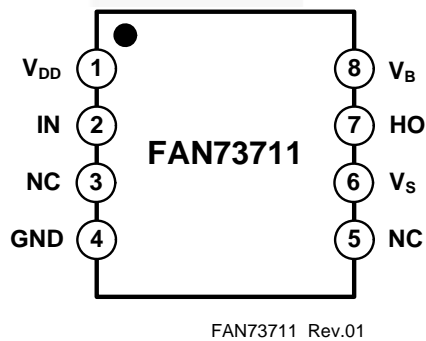

Figure 4. Pin Configuration (Top View)

Pin Definitions

| Pin # | Name | Description |
|-------|-----------------|----------------------------------------------|
| 1 | V _{DD} | Supply Voltage |
| 2 | IN | Logic Input for High-Side Gate Driver Output |
| 3 | NC | No Connection |
| 4 | GND | Ground |
| 5 | NC | No Connection |
| 6 | V _S | High-Voltage Floating Supply Return |
| 7 | HO | High-Side Driver Output |
| 8 | V _B | High-Side Floating Supply |

Absolute Maximum Ratings

Stresses exceeding the absolute maximum ratings may damage the device. The device may not function or be operable above the recommended operating conditions and stressing the parts to these levels is not recommended. In addition, extended exposure to stresses above the recommended operating conditions may affect device reliability. The absolute maximum ratings are stress ratings only. $T_A=25^{\circ}\text{C}$ unless otherwise specified.

| Symbol | Characteristics | Min. | Max. | Unit |
|---------------|--------------------------------------------------|-------------------|----------------|-----------------------------|
| V_S | High-Side Floating Offset Voltage ⁽¹⁾ | $V_B - V_{SHUNT}$ | $V_B + 0.3$ | V |
| V_B | High-Side Floating Supply Voltage | -0.3 | 625.0 | V |
| V_{HO} | High-Side Floating Output Voltage | $V_S - 0.3$ | $V_B + 0.3$ | V |
| V_{DD} | Low-Side and Logic Supply Voltage ⁽¹⁾ | -0.3 | V_{SHUNT} | V |
| V_{IN} | Logic Input Voltage | -0.3 | $V_{DD} + 0.3$ | V |
| dV_S/dt | Allowable Offset Voltage Slew Rate | | ± 50 | V/ns |
| P_D | Power Dissipation ^(2,3,4) | | 0.625 | W |
| θ_{JA} | Thermal Resistance | | 200 | $^{\circ}\text{C}/\text{W}$ |
| T_J | Junction Temperature | -55 | +150 | $^{\circ}\text{C}$ |
| T_{STG} | Storage Temperature | -55 | +150 | $^{\circ}\text{C}$ |

Notes:

- This IC contains a shunt regulator on V_{DD} and V_{BS} . This supply pin should not be driven by a low-impedance voltage source greater than the V_{SHUNT} specified in the Electrical Characteristics section.
- Mounted on 76.2 x 114.3 x 1.6 mm PCB (FR-4 glass epoxy material).
- Refer to the following standards:
JESD51-2: Integral circuits thermal test method environmental conditions, natural convection, and
JESD51-3: Low effective thermal conductivity test board for leaded surface-mount packages.
- Do not exceed power dissipation (P_D) under any circumstances.

Recommended Operating Conditions

The Recommended Operating Conditions table defines the conditions for actual device operation. Recommended operating conditions are specified to ensure optimal performance to the datasheet specifications. Fairchild does not recommend exceeding them or designing to absolute maximum ratings.

| Symbol | Parameter | Min. | Max. | Unit |
|----------|------------------------------------------|--------------|------------|--------------------|
| V_B | High-Side Floating Supply Voltage | $V_S + 10$ | $V_S + 20$ | V |
| V_S | High-Side Floating Supply Offset Voltage | $6 - V_{DD}$ | 600 | V |
| V_{HO} | High-Side Output Voltage | V_S | V_B | V |
| V_{IN} | Logic Input Voltage | GND | V_{DD} | V |
| V_{DD} | Supply Voltage | 10 | 20 | V |
| T_A | Operating Ambient Temperature | -40 | +125 | $^{\circ}\text{C}$ |

Electrical Characteristics

$V_{BIAS}(V_{DD}, V_{BS})=15.0\text{ V}$, $T_A = 25^\circ\text{C}$, unless otherwise specified. The V_{IN} and I_{IN} parameters are referenced to GND. The V_O and I_O parameters are relative to V_S and are applicable to the respective output HO.

| Symbol | Characteristics | Test Condition | Min. | Typ. | Max. | Unit |
|------------------------------------|----------------------------------------------------------------------|-------------------------------------------------------------------------|------|------|------|------------------|
| Power Supply Section | | | | | | |
| I_{QDD} | Quiescent V_{DD} Supply Current | $V_{IN}=0\text{ V or }5\text{ V}$ | | 25 | 70 | μA |
| I_{PDD} | Operating V_{DD} Supply Current | $f_{IN}=20\text{ kHz, No Load}$ | | 35 | 100 | μA |
| Bootstrapped Supply Section | | | | | | |
| V_{BSUV+} | V_{BS} Supply Under-Voltage Positive-Going Threshold Voltage | $V_{BS}=\text{Sweep}$ | 8.0 | 9.0 | 10.0 | V |
| V_{BSUV-} | V_{BS} Supply Under-Voltage Negative-Going Threshold Voltage | $V_{BS}=\text{Sweep}$ | 7.3 | 8.3 | 9.3 | V |
| V_{BSHYS} | V_{BS} Supply Under-Voltage Lockout Hysteresis Voltage | $V_{BS}=\text{Sweep}$ | | 0.7 | | V |
| I_{LK} | Offset Supply Leakage Current | $V_B=V_S=625\text{ V}$ | | | 10 | μA |
| I_{QBS} | Quiescent V_{BS} Supply Current | $V_{IN}=0\text{V or }5\text{ V}$ | | 60 | 120 | μA |
| I_{PBS} | Operating V_{BS} Supply Current | $C_{LOAD}=1000\text{ pF, }f_{IN}=20\text{ kHz, rms Value}$ | | 470 | 800 | μA |
| Shunt Regulator Section | | | | | | |
| V_{SHUNT} | V_{DD} and V_{BS} Shunt Regulator Clamping Voltage | $V_{DD}=\text{Sweep or }V_{BS}=\text{Sweep}$ $I_{SHUNT}=5\text{ mA}$ | 21 | 23 | 25 | V |
| Input Logic Section | | | | | | |
| V_{IH} | Logic "1" Input Voltage | | 2.5 | | | V |
| V_{IL} | Logic "0" Input Voltage | | | | 0.8 | V |
| I_{IN+} | Logic Input High Bias Current | $V_{IN}=5\text{ V}$ | | 40 | 65 | μA |
| I_{IN-} | Logic Input Low Bias Current | $V_{IN}=0\text{ V}$ | | | 2 | μA |
| R_{IN} | Input Pull-Down Resistance | | 90 | 110 | | $\text{K}\Omega$ |
| Gate Driver Output Section | | | | | | |
| V_{OH} | High Level Output Voltage ($V_{BIAS} - V_O$) | No Load | | | 1.2 | V |
| V_{OL} | Low Level Output Voltage | No Load | | | 30 | mV |
| I_{O+} | Output High, Short-Circuit Pulsed Current ⁽⁵⁾ | $V_{HO}=0\text{ V, }V_{IN}=5\text{ V, }PW \leq 10\ \mu\text{s}$ | 3 | 4 | | A |
| I_{O-} | Output Low, Short-Circuit Pulsed Current ⁽⁵⁾ | $V_{HO}=15\text{ V, }V_{IN}=0\text{ V, }PW \leq 10\ \mu\text{s}$ | 3 | 4 | | A |
| V_S | Allowable Negative V_S Pin Voltage for IN Signal Propagation to HO | | | -9.8 | -7.0 | V |

Note:

5. These parameters guaranteed by design.

Dynamic Electrical Characteristics

$V_{DD}=V_{BS}=15\text{ V}$, $\text{GND}=0\text{ V}$, $C_{LOAD}=1000\text{ pF}$, $T_A=25^\circ\text{C}$, unless otherwise specified.

| Symbol | Parameter | Conditions | Min. | Typ. | Max. | Unit |
|-----------|----------------------------|------------------|------|------|------|------|
| t_{on} | Turn-On Propagation Delay | $V_S=0\text{ V}$ | | 150 | 210 | ns |
| t_{off} | Turn-Off Propagation Delay | $V_S=0\text{ V}$ | | 150 | 210 | ns |
| t_r | Turn-On Rise Time | | | 25 | 50 | ns |
| t_f | Turn-Off Fall Time | | | 15 | 40 | ns |

Typical Characteristics

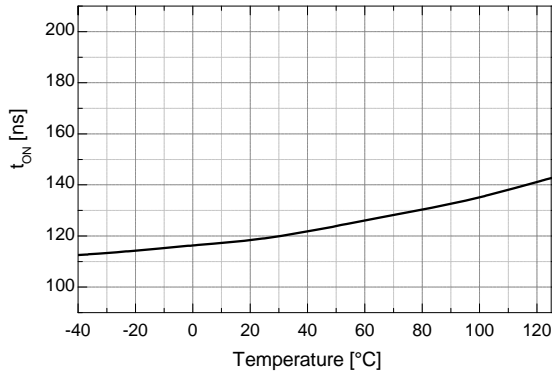

Figure 5. Turn-On Propagation Delay vs. Temperature

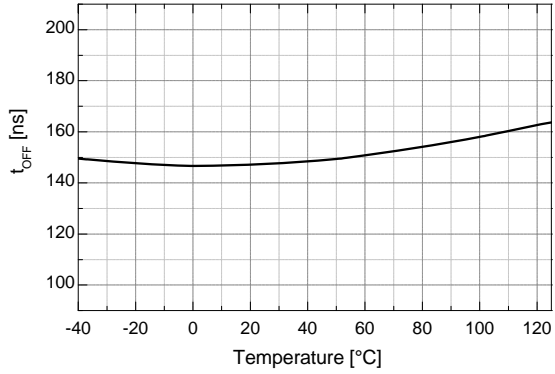

Figure 6. Turn-Off Propagation Delay vs. Temperature

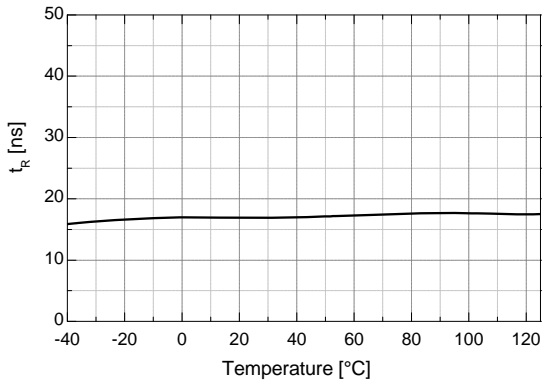

Figure 7. Turn-On Rise Time vs. Temperature

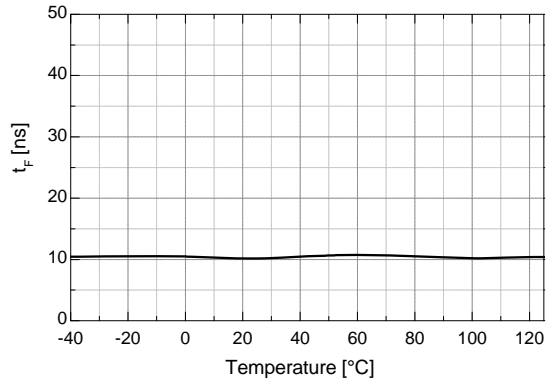

Figure 8. Turn-Off Fall Time vs. Temperature

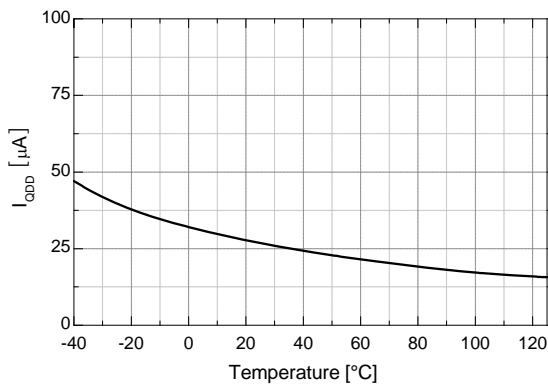

Figure 9. Quiescent V_{DD} Supply Current vs. Temperature

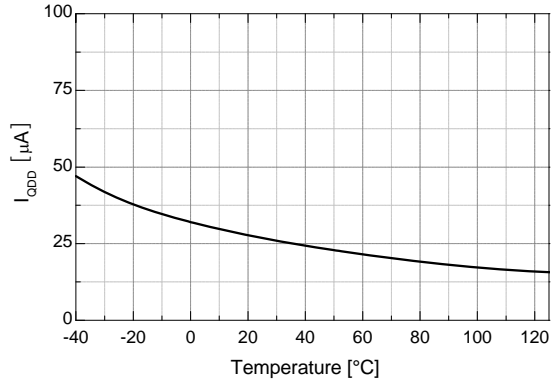

Figure 10. Quiescent V_{BS} Supply Current vs. Temperature

Typical Characteristics (Continued)

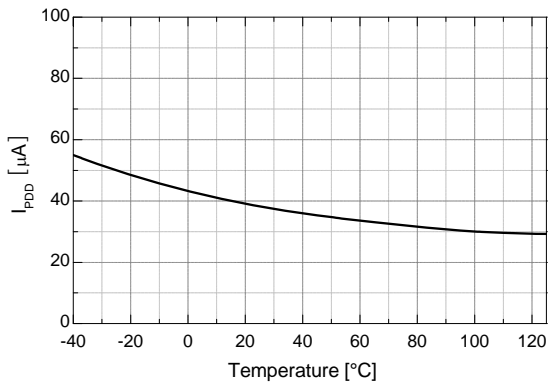

Figure 11. Operating V_{DD} Supply Current vs. Temperature

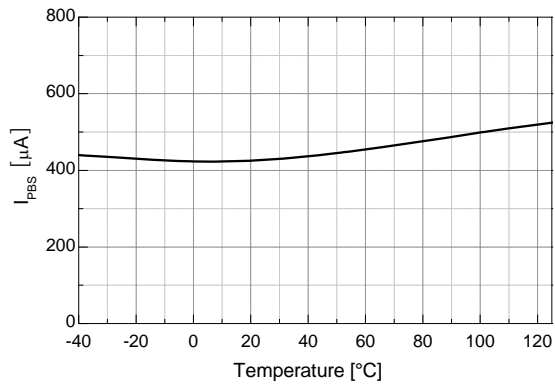

Figure 12. Operating V_{BS} Supply Current vs. Temperature

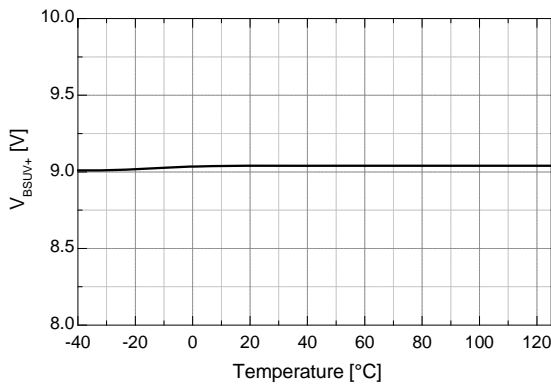

Figure 13. V_{BS} UVLO+ vs. Temperature

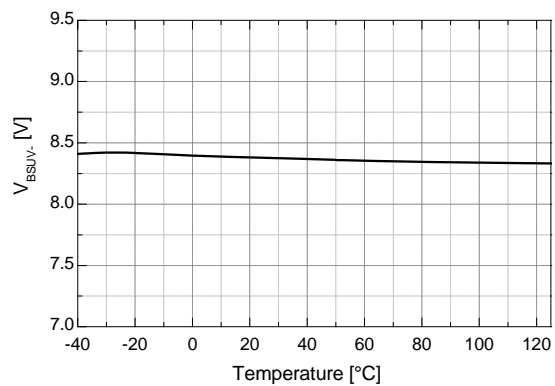

Figure 14. V_{BS} UVLO- vs. Temperature

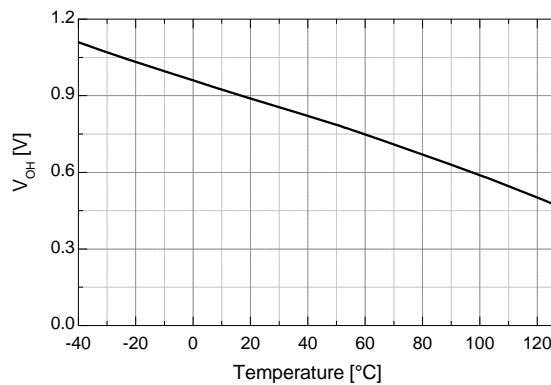

Figure 15. High-Level Output Voltage vs. Temperature

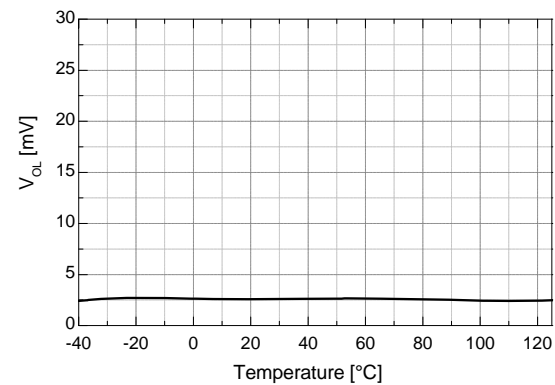

Figure 16. Low-Level Output Voltage vs. Temperature

Typical Characteristics (Continued)

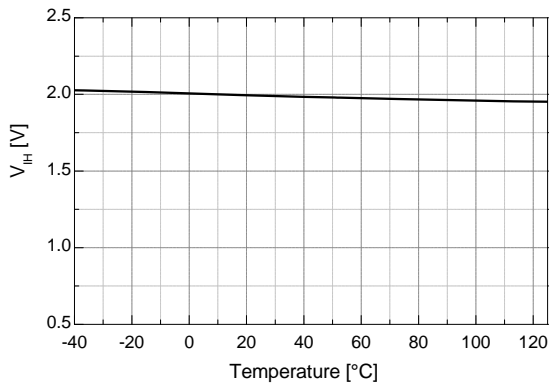

Figure 17. Logic High Input Voltage vs. Temperature

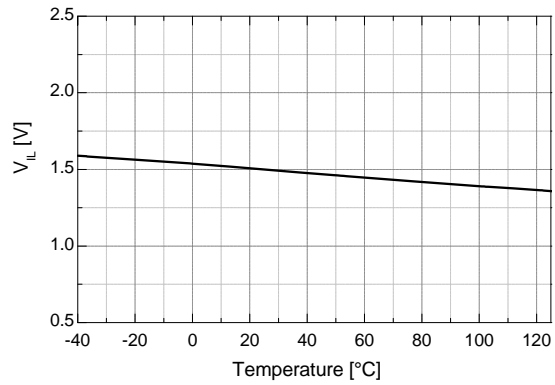

Figure 18. Logic Low Input Voltage vs. Temperature

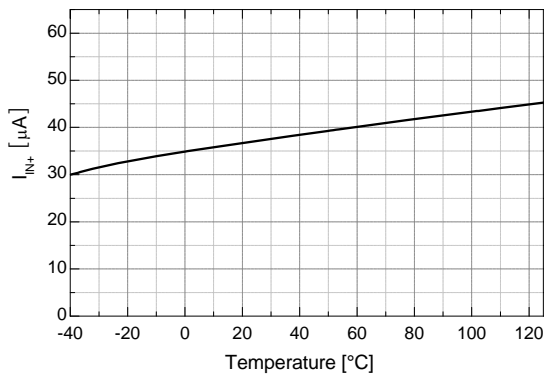

Figure 19. Logic Input High Bias Current vs. Temperature

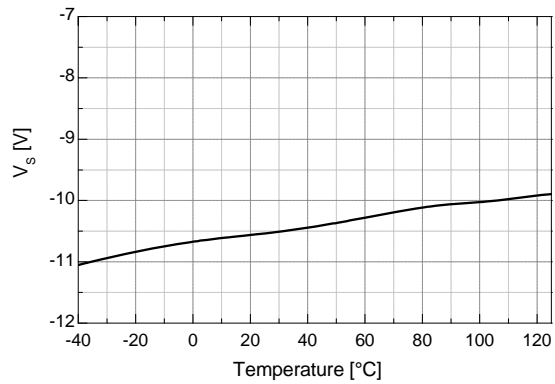

Figure 20. Allowable Negative V_S Voltage vs. Temperature

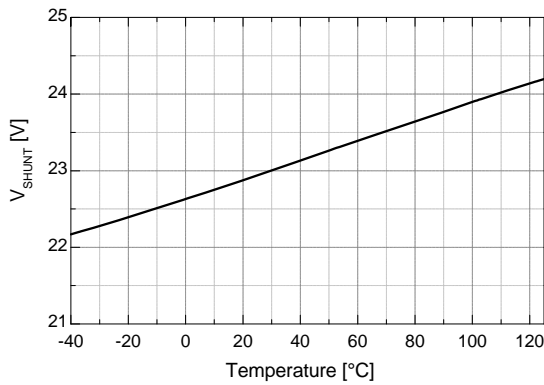

Figure 21. Shunt Regulator Clamping Voltage vs. Temperature

Switching Time Definitions

Timing Diagram

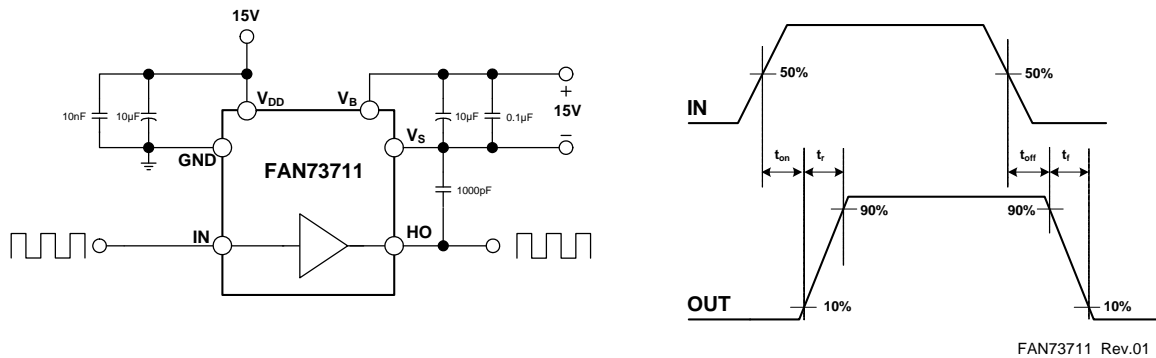

Figure 22. Switching Time Test Circuit and Waveform Definitions

Package Dimensions

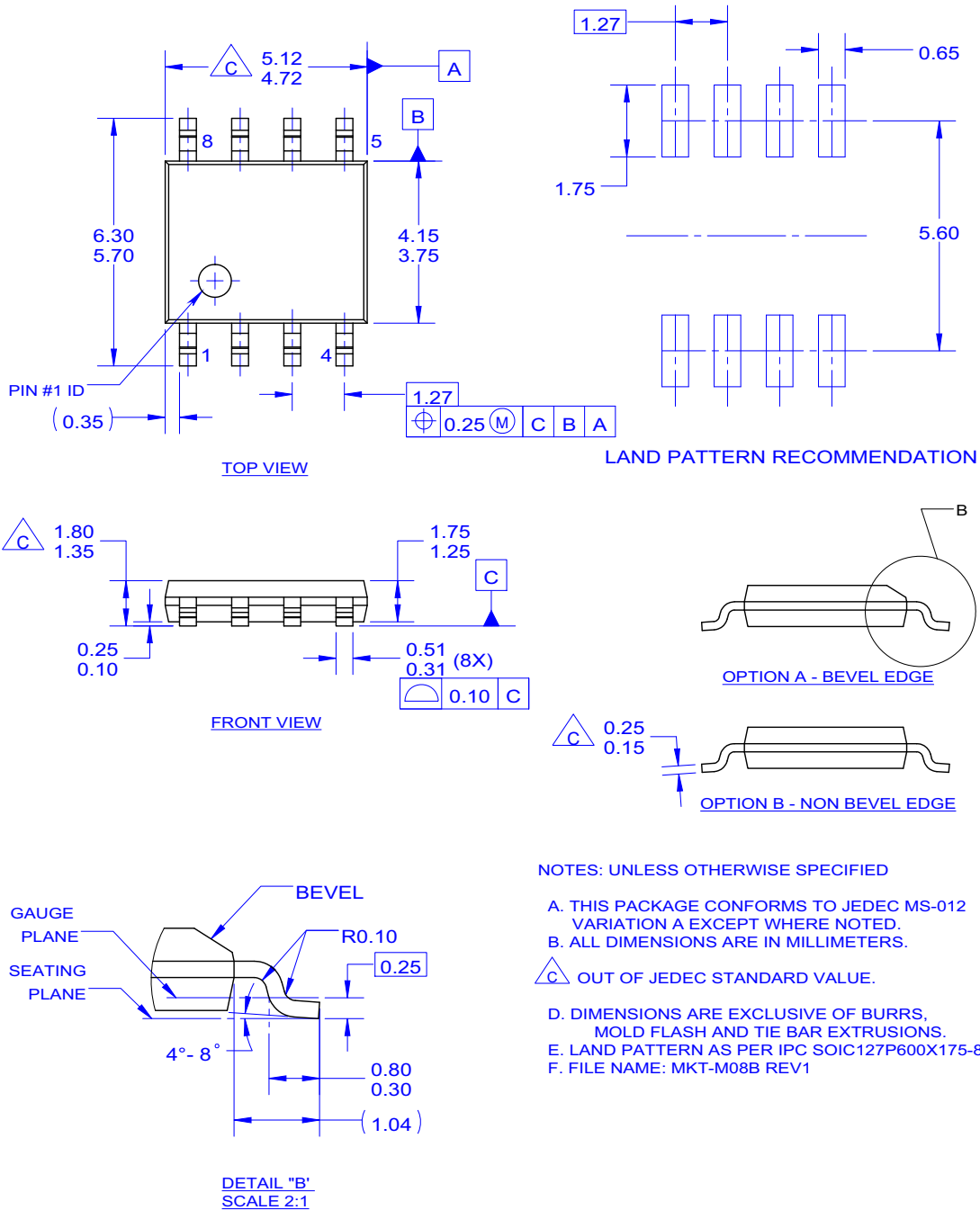

Figure 23. 8-Lead Small Outline Package (SOP)

Package drawings are provided as a service to customers considering Fairchild components. Drawings may change in any manner without notice. Please note the revision and/or date on the drawing and contact a Fairchild Semiconductor representative to verify or obtain the most recent revision. Package specifications do not expand the terms of Fairchild's worldwide terms and conditions, specifically the warranty therein, which covers Fairchild products.

Always visit Fairchild Semiconductor's online packaging area for the most recent package drawings:

<http://www.fairchildsemi.com/packaging/>

TRADEMARKS

The following includes registered and unregistered trademarks and service marks, owned by Fairchild Semiconductor and/or its global subsidiaries, and is not intended to be an exhaustive list of all such trademarks.

- | | | | |
|----------------------------------------------------------------------------------------------|------------------------------------------------|-------------------------------------------------------------------------------------|-----------------------------------------------------------------------------------------------------|
| 2Cool™ | FPS™ |  | Sync-Lock™ |
| AccuPower™ | F-PFS™ | PowerTrench® |  SYSTEM GENERAL® |
| AX-CAP®* | FRFET® | PowerXS™ | TinyBoost™ |
| BitSiC™ | Global Power Resource™ | Programmable Active Droop™ | TinyBuck™ |
| Build it Now™ | GreenBridge™ | QFET® | TinyCalc™ |
| CorePLUS™ | Green FPS™ | QS™ | TinyLogic® |
| CorePOWER™ | Green FPS™ e-Series™ | Quiet Series™ | TINYOPTO™ |
| CROSSVOLT™ | Gmax™ | RapidConfigure™ | TinyPower™ |
| CTL™ | GTO™ |  ™ | TinyPVM™ |
| Current Transfer Logic™ | IntelliMAX™ | Saving our world, 1mW/W/kW at a time™ | TinyWire™ |
| DEUXPEED® | ISOPLANAR™ | SignalWise™ | TranSiC™ |
| Dual Cool™ | Making Small Speakers Sound Louder and Better™ | SmartMax™ | TriFault Detect™ |
| EcoSPARK® | MegaBuck™ | SMART START™ | TRUECURRENT®* |
| EfficientMax™ | MICROCOUPLER™ | Solutions for Your Success™ | µSerDes™ |
| ESBC™ | MicroFET™ | SPM® |  SerDes™ |
|  Fairchild® | MicroPak™ | STEALTH™ | UHC® |
| Fairchild Semiconductor® | MicroPak2™ | SuperFET® | Ultra FRFET™ |
| FACT Quiet Series™ | MillerDrive™ | SuperSOT™-3 | UniFET™ |
| FACT® | MotionMax™ | SuperSOT™-6 | VCX™ |
| FAST® | mWSaver™ | SuperSOT™-8 | VisualMax™ |
| FastvCore™ | OptoHiT™ | SupreMOS® | VoltagePlus™ |
| FETBench™ | OPTOLOGIC® | SyncFET™ | XS™ |
| | OPTOPLANAR® | | |

* Trademarks of System General Corporation, used under license by Fairchild Semiconductor.

DISCLAIMER

FAIRCHILD SEMICONDUCTOR RESERVES THE RIGHT TO MAKE CHANGES WITHOUT FURTHER NOTICE TO ANY PRODUCTS HEREIN TO IMPROVE RELIABILITY, FUNCTION, OR DESIGN. FAIRCHILD DOES NOT ASSUME ANY LIABILITY ARISING OUT OF THE APPLICATION OR USE OF ANY PRODUCT OR CIRCUIT DESCRIBED HEREIN; NEITHER DOES IT CONVEY ANY LICENSE UNDER ITS PATENT RIGHTS, NOR THE RIGHTS OF OTHERS. THESE SPECIFICATIONS DO NOT EXPAND THE TERMS OF FAIRCHILD'S WORLDWIDE TERMS AND CONDITIONS, SPECIFICALLY THE WARRANTY THEREIN, WHICH COVERS THESE PRODUCTS.

LIFE SUPPORT POLICY

FAIRCHILD'S PRODUCTS ARE NOT AUTHORIZED FOR USE AS CRITICAL COMPONENTS IN LIFE SUPPORT DEVICES OR SYSTEMS WITHOUT THE EXPRESS WRITTEN APPROVAL OF FAIRCHILD SEMICONDUCTOR CORPORATION.

As used herein:

1. Life support devices or systems are devices or systems which, (a) are intended for surgical implant into the body or (b) support or sustain life, and (c) whose failure to perform when properly used in accordance with instructions for use provided in the labeling, can be reasonably expected to result in a significant injury of the user.
2. A critical component in any component of a life support, device, or system whose failure to perform can be reasonably expected to cause the failure of the life support device or system, or to affect its safety or effectiveness.

ANTI-COUNTERFEITING POLICY

Fairchild Semiconductor Corporation's Anti-Counterfeiting Policy. Fairchild's Anti-Counterfeiting Policy is also stated on our external website, www.fairchildsemi.com, under Sales Support.

Counterfeiting of semiconductor parts is a growing problem in the industry. All manufacturers of semiconductor products are experiencing counterfeiting of their parts. Customers who inadvertently purchase counterfeit parts experience many problems such as loss of brand reputation, substandard performance, failed applications, and increased cost of production and manufacturing delays. Fairchild is taking strong measures to protect ourselves and our customers from the proliferation of counterfeit parts. Fairchild strongly encourages customers to purchase Fairchild parts either directly from Fairchild or from Authorized Fairchild Distributors who are listed by country on our web page cited above. Products customers buy either from Fairchild directly or from Authorized Fairchild Distributors are genuine parts, have full traceability, meet Fairchild's quality standards for handling and storage and provide access to Fairchild's full range of up-to-date technical and product information. Fairchild and our Authorized Distributors will stand behind all warranties and will appropriately address any warranty issues that may arise. Fairchild will not provide any warranty coverage or other assistance for parts bought from Unauthorized Sources. Fairchild is committed to combat this global problem and encourage our customers to do their part in stopping this practice by buying direct or from authorized distributors.

PRODUCT STATUS DEFINITIONS

Definition of Terms

| Datasheet Identification | Product Status | Definition |
|--------------------------|-----------------------|-----------------------------------------------------------------------------------------------------------------------------------------------------------------------------------------------------|
| Advance Information | Formative / In Design | Datasheet contains the design specifications for product development. Specifications may change in any manner without notice. |
| Preliminary | First Production | Datasheet contains preliminary data; supplementary data will be published at a later date. Fairchild Semiconductor reserves the right to make changes at any time without notice to improve design. |
| No Identification Needed | Full Production | Datasheet contains final specifications. Fairchild Semiconductor reserves the right to make changes at any time without notice to improve the design. |
| Obsolete | Not In Production | Datasheet contains specifications on a product that is discontinued by Fairchild Semiconductor. The datasheet is for reference information only. |

Rev. I64