

FAN7556

Voltage Mode PWM Controller

Features

- Voltage Mode Control
- Pulse by Pulse Current Limiting
- Low External Components
- Under Voltage Lockout (UVLO): 9V/15V
- Stand-by Current: Typ. 100uA
- Power Saving Mode Current: Typ. 200uA
- Operating Current: Typ. 7mA
- Soft Start
- On/off Control
- Over Load Protection (OLP)
- Over Current Protection (OCP)
- Over Voltage Protection (OVP)
- Wide Operating Frequency Range (20kHz ~ 500kHz)
- Auto-Restart Function

Applications

- Off-Line & DC-DC Converter

Description

The FAN7556 is a fixed frequency voltage mode PWM controller. It is specially designed for off-line and DC-DC converter applications with minimal external components. These integrated circuits feature a trimmed oscillator for precise duty cycle control, a temperature compensated reference, an on/off control, a high gain error amplifier, a current sensing comparator, and a high current totem-pole output. The FAN7556 has various protection functions such as an over load protection (OLP), an over current protection(OCP), and an over voltage protection(OVP). The FAN7556 is available in the 8DIP package as well as the 8SOP package.

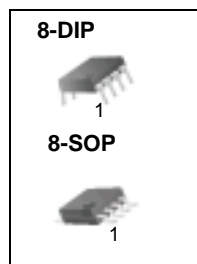

Internal Block Diagram

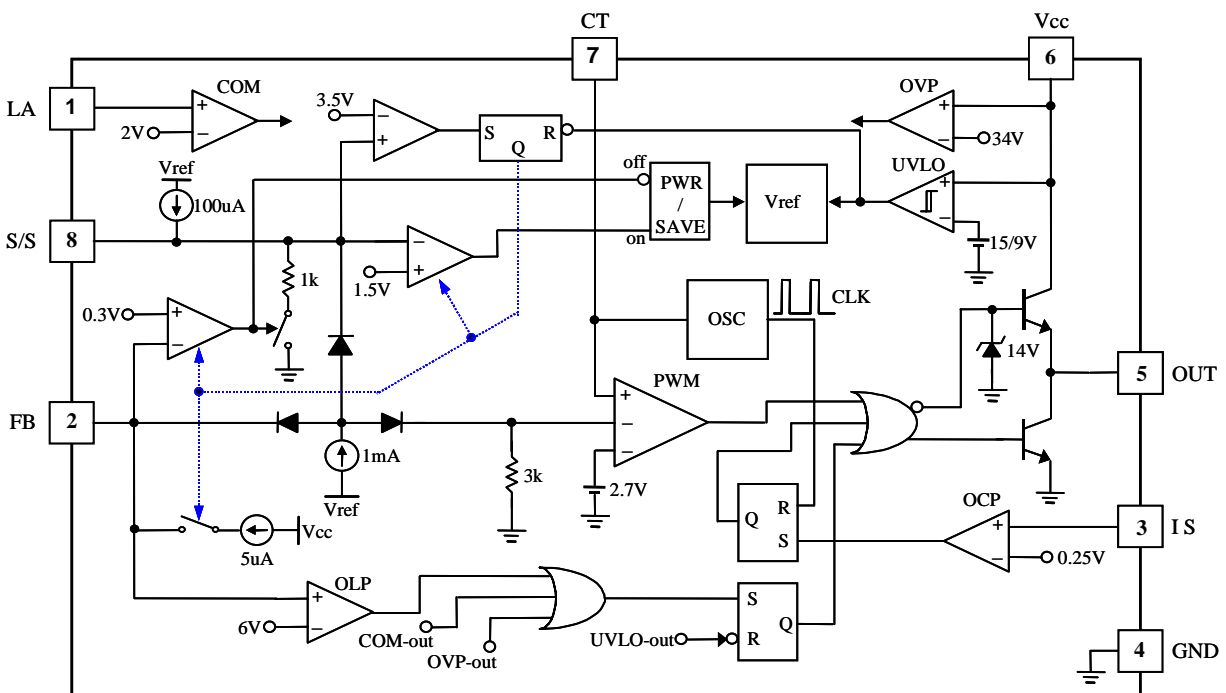

Absolute Maximum Ratings

(Ta = 25°C, unless otherwise specified)

Parameter	Symbol	Value	Unit
Supply Voltage	V _{CC}	30	V
Output Current	I _O	±1	A
Input Voltage to FB Pin	V _{FB}	V _{SD}	V
Input Voltage to IS Pin	V _{IS}	-0.3 to V _{OC}	V
Power Dissipation (Ta ≤ 25°C) 8-DIP 8-SOP	P _D	0.85 0.62	W
Operating Temperature	T _{OPR}	-25 to +125	°C
Storage Temperature	T _{STG}	-55 to +150	°C
Thermal Resistance, Junction-to-Air(Note1) 8-DIP 8-SOP	R _{θja}	147.1 201.6	°C/W

Note:

- Junction -to -air thermal resistance test environments.
 - Pneumatic heat sink fixture.
 - Clamping pressure 60psi through 12mm diameter cylinder.
 - Thermal grease applied between PKG and heat sink fixture

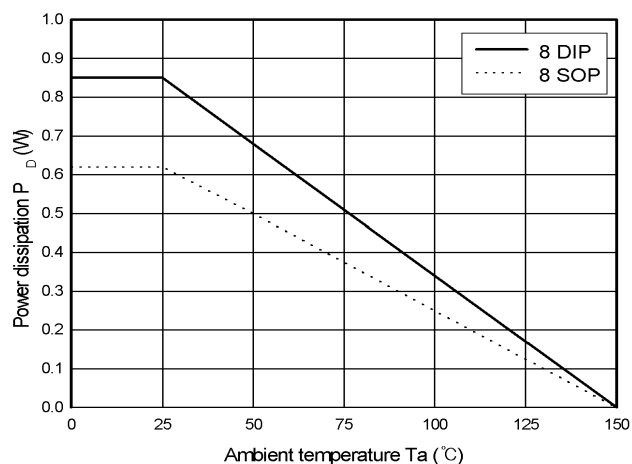

Temperature Characteristics

(-25°C ≤ Ta ≤ 125°C)

Parameter	Symbol	Value	Unit
Fosc Temperature Stability	ΔFOSC2	±5	%

PIN Array

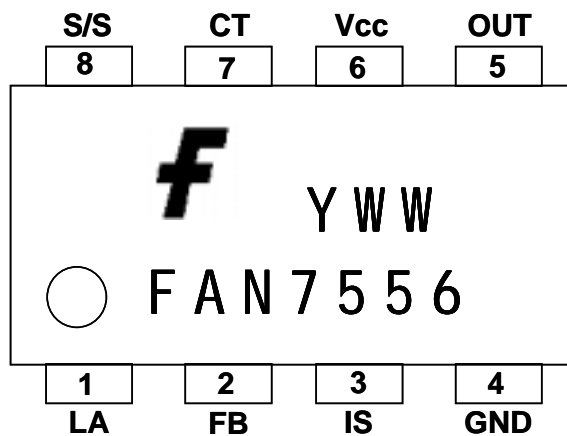

YWW : Work Week Code

PIN Definitions

Pin Number	Pin Name	Pin Function Description
1	LA	Optional Protection
2	FB	Inverting (-) Input of PWM Comparator, ON/OFF Control & Over Load Sensing
3	IS	Over Current Sensing
4	GND	Ground
5	OUT	Output of Gate Driver
6	Vcc	Power Supply
7	CT	Oscillator Timing Capacitor Ct
8	S/S	Soft Start

Electrical Characteristics

(Ta = 25°C, Vcc=18V, Ct=1nF unless otherwise specified)

Parameter	Symbol	Conditions	Min.	Typ.	Max.	Unit
< OSCILLATOR SECTION >						
Oscillator Frequency	FOSC	Tj =25°C, Ct=1nF	90	100	110	kHz
Frequency Change With Vcc	ΔFOSC1	Vcc=10V~30V	-	±1	-	%
Temperature Stability (Note1)	ΔFOSC2	-25°C ≤ Ta ≤ 125°C	-	±5	-	%
< PWM SECTION >						
FB Source Current	IFB	VFB = 0V, VS/S = 5V	-	1.0	-	mA
FB Threshold Voltage 1	VTH(FBO)	Duty = 0%	-	0.85	-	V
FB Threshold Voltage 2	VTH(FBM)	Duty = DMAX	-	2.7	-	V
Maximum Duty Cycle	DMAX	-	70	74	78	%
< SOFT START SECTION >						
Soft Start Current	IS/S	VFB = 5V, VS/S = 0V	-	1.1	-	mA
Soft Start Limit Voltage	VLIM(S/S)	-	-	5.2	-	V
< PROTECTION SECTION >						
Shutdown Feedback Voltage	VSD	VFB > 5V	5.4	6	6.6	V
Shutdown Delay Current	ISD	4V ≤ VFB ≤ VSD	3.5	5	6.5	uA
Over Current Protection	VOC	-	0.22	0.26	0.29	V
Over Voltage Protection	VOVP	VFB = 3V, VS/S = 5V	30	34	38	V
Comparator Threshold Voltage	VLA	-	1.7	2	2.3	V
< UVLO SECTION >						
Start Threshold Voltage	VTH(ST)	-	13.2	14.7	16.2	V
Min. Operating Voltage	VOPR(MIN)	-	8.2	9.2	10.2	V
< ON/OFF CONTROL SECTION >						
On Threshold Voltage	VON	VIS = 0V	0.2	0.3	0.4	V
Off Threshold Voltage	VOFF	VFB < VON	1.2	1.5	1.8	V
Sink Current	ISINK	VFB < VTH(FB), VS/S = 5V	3	4	5	mA
< OUTPUT SECTION >						
Low Output Voltage1	VOL1	Io = 50mA	-	0.15	0.4	V
Low Output Voltage2	VOL2	Io = 200mA	-	1.5	2.5	V
High Output Voltage1	VOH1	Io = -50mA	13	15	17	V
High Output Voltage2	VOH2	Io = -200mA	12	14	16	V
Rise Time (Note1)	TR	CL= 1nF, (No load)	-	80	-	ns
Fall Time (Note1)	TF	CL= 1nF, (No load)	-	40	-	ns
< OVERALL SECTION >						
Start-Up Current	VST	-	-	0.1	0.2	mA
Operating Supply Current	IOP	Vcc ≤ 30V	-	7	10	mA
Off State Current	IOFF	VFB < VTH(FB), VS/S < VOFF	-	0.2	0.4	mA

Note:

1. These parameters, although guaranteed, are not 100% tested in production.

Typical Performance Characteristics

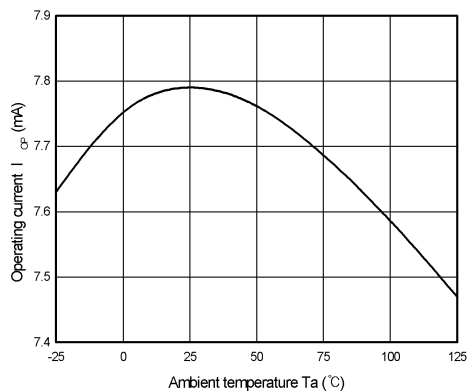

Figure 1. Operating Current vs. Ambient Temperature

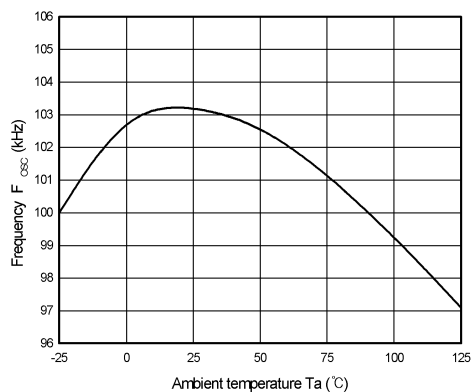

Figure 2. Frequency vs. Ambient Temperature

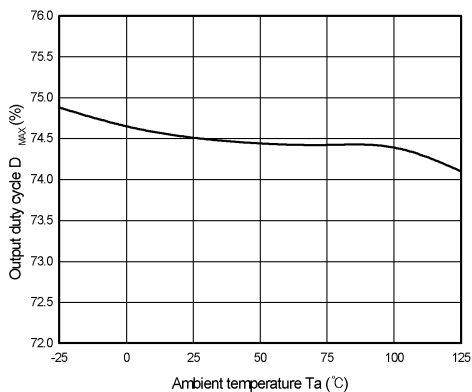

Figure 3. Output Duty Cycle vs. Ambient Temperature

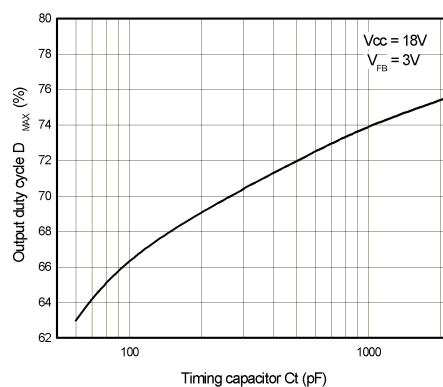

Figure 4. Output Duty Cycle vs. Timing Capacitor

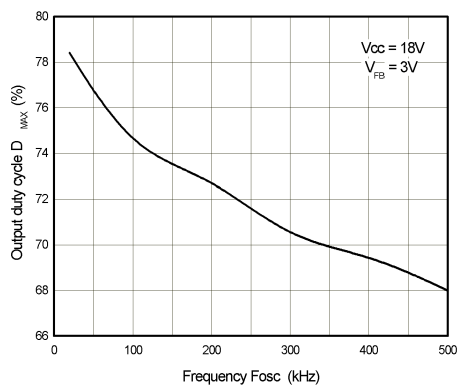

Figure 5. Output Duty Cycle vs. Frequency

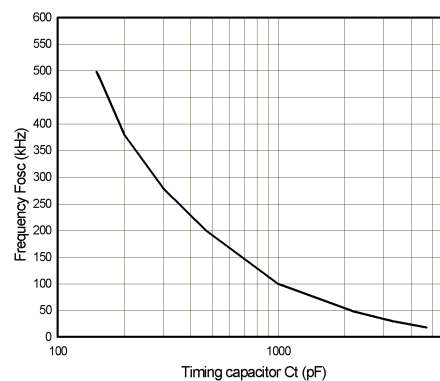

Figure 6. Frequency vs. Timing Capacitor

Typical Performance Characteristics (Continued)

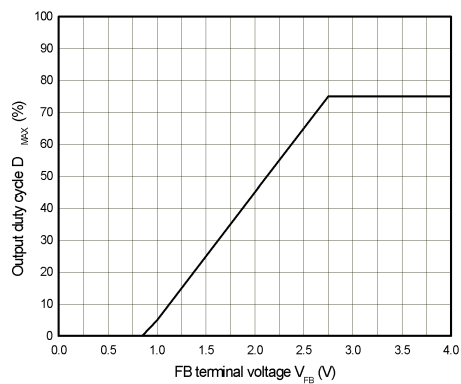

Figure 7. Output Duty Cycle vs. FB Terminal Voltage

Mechanical Dimensions

Package

Dimensions in millimeters

8-DIP

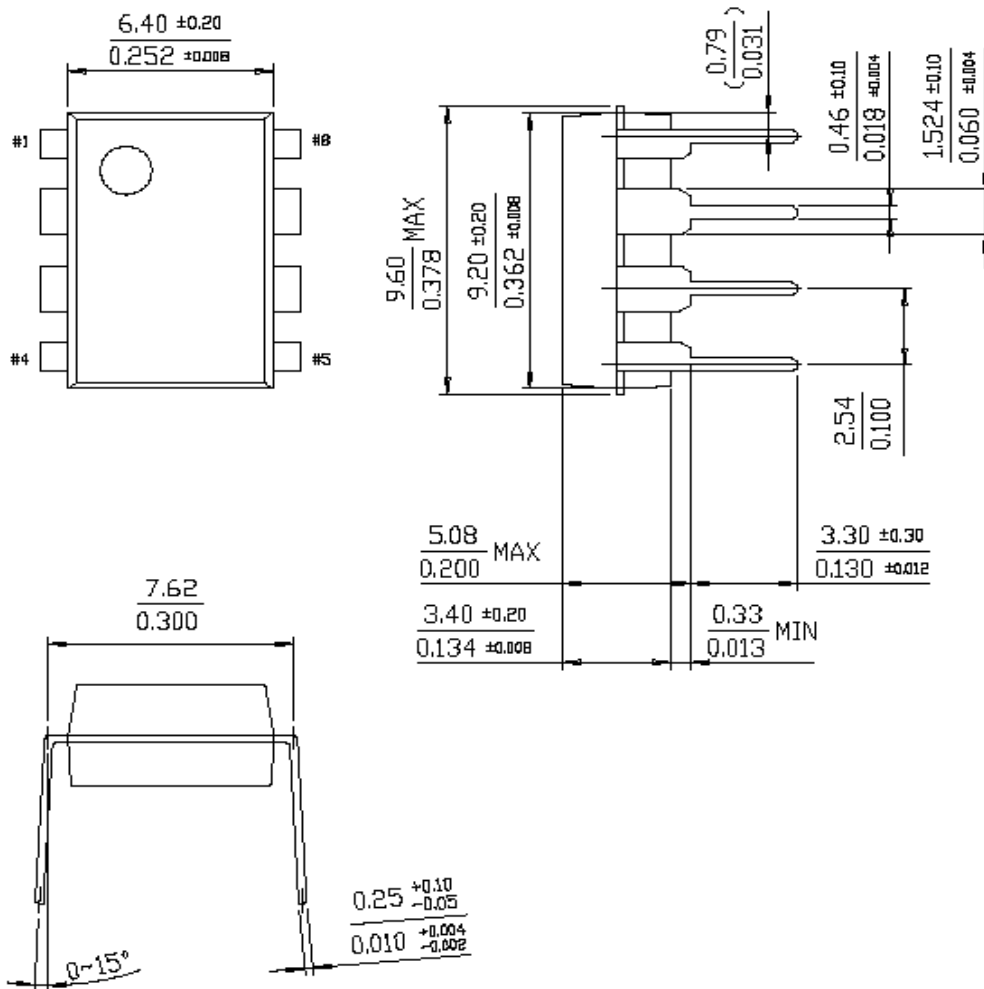

Mechanical Dimensions (Continued)

Package

Dimensions in millimeters

8-SOP

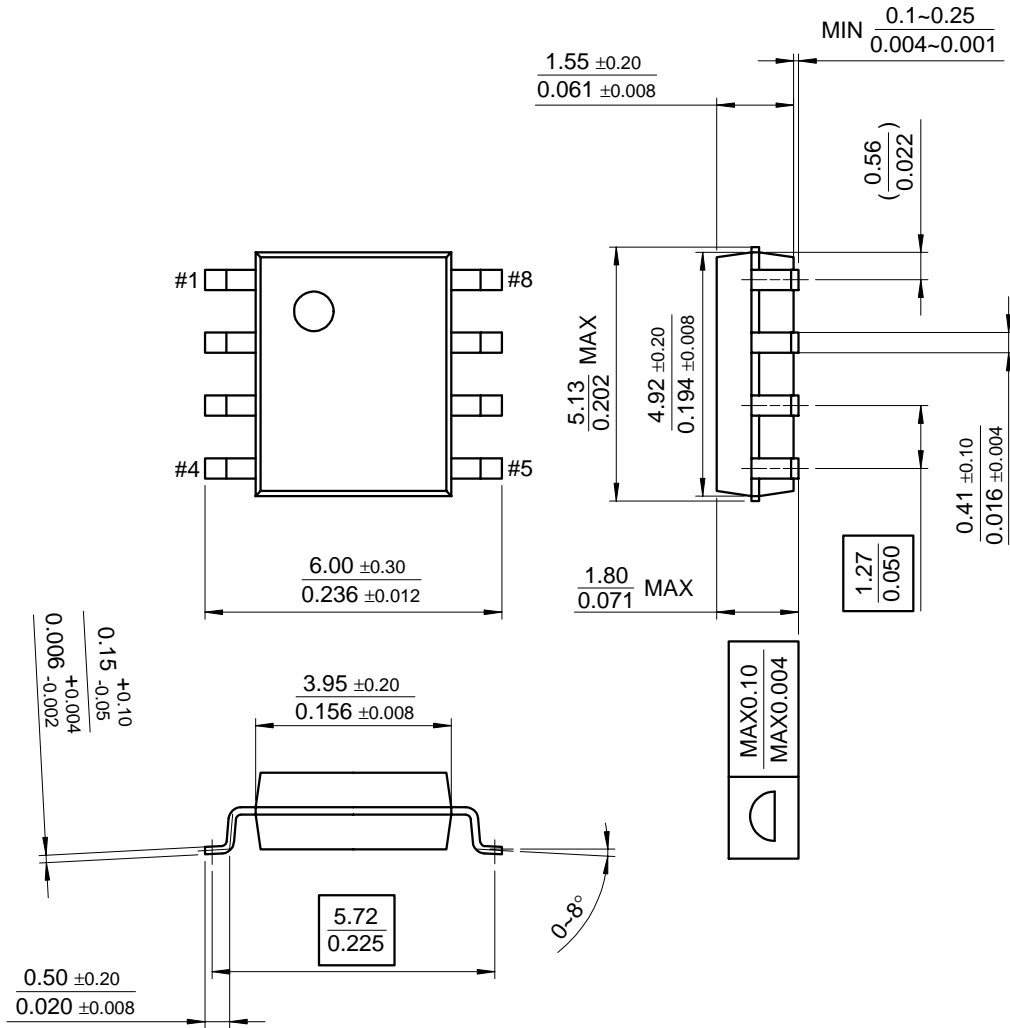

Ordering Information

Product Number	Package	Operating Temperature	Packing
FAN7556N	8-DIP	-25°C ~ 125°C	Tube
FAN7556M	8-SOP		Tube
FAN7556MX	8-SOP		Tape&Reel

DISCLAIMER

FAIRCHILD SEMICONDUCTOR RESERVES THE RIGHT TO MAKE CHANGES WITHOUT FURTHER NOTICE TO ANY PRODUCTS HEREIN TO IMPROVE RELIABILITY, FUNCTION OR DESIGN. FAIRCHILD DOES NOT ASSUME ANY LIABILITY ARISING OUT OF THE APPLICATION OR USE OF ANY PRODUCT OR CIRCUIT DESCRIBED HEREIN; NEITHER DOES IT CONVEY ANY LICENSE UNDER ITS PATENT RIGHTS, NOR THE RIGHTS OF OTHERS.

LIFE SUPPORT POLICY

FAIRCHILD'S PRODUCTS ARE NOT AUTHORIZED FOR USE AS CRITICAL COMPONENTS IN LIFE SUPPORT DEVICES OR SYSTEMS WITHOUT THE EXPRESS WRITTEN APPROVAL OF THE PRESIDENT OF FAIRCHILD SEMICONDUCTOR CORPORATION. As used herein:

1. Life support devices or systems are devices or systems which, (a) are intended for surgical implant into the body, or (b) support or sustain life, and (c) whose failure to perform when properly used in accordance with instructions for use provided in the labeling, can be reasonably expected to result in a significant injury of the user.
2. A critical component in any component of a life support device or system whose failure to perform can be reasonably expected to cause the failure of the life support device or system, or to affect its safety or effectiveness.