

FAN7602C

Green Current Mode PWM Controller

Features

- Green Current Mode PWM Controller
- Random Frequency Fluctuation for Low EMI
- Internal High-Voltage Startup Switch
- Burst Mode Operation
- Line Voltage Feedforward to Limit Maximum Power
- Line Under-Voltage Protection
- Latch Protection & Internal Soft-Start (10ms) Function
- Overload Protection (OLP)
- Over-Voltage Protection (OVP)
- Over-Temperature Protection (OTP)
- Low Operation Current: 1 mA Typical
- Available in the 8-Lead SOP Package

Applications

- Adapter
- LCD Monitor Power
- Auxiliary Power Supply

Related Resources

- [AN-6014- Green Current Mode PWM Controller](#)
(Except for frequency fluctuation part in AN-6014)

Description

The FAN7602C is a green current-mode PWM controller. It is specially designed for off-line adapter applications; DVDP, VCR, LCD monitor applications; and auxiliary power supplies.

The internal high-voltage startup switch and the burst mode operation reduce the power loss in standby mode. As a result, the input power is lower than 1 W when the input line voltage is 265 V_{AC} and the load is 0.5 W. At no-load condition, input power is under 0.15 W.

The maximum power can be limited constantly, regardless of the line voltage change, using the power limit function.

The switching frequency is not fixed and has random frequency fluctuation.

The FAN7602C includes various protections for the system reliability and the internal soft-start prevents the output voltage over-shoot at startup.

Ordering Information

Part Number	Operating Junction Temperature	Package	Packing Method	Top Mark
FAN7602CMX	-40°C to +150°C	8-Lead Small Outline Package (SOP)	Tape and Reel	FAN7602C

Typical Application Diagram

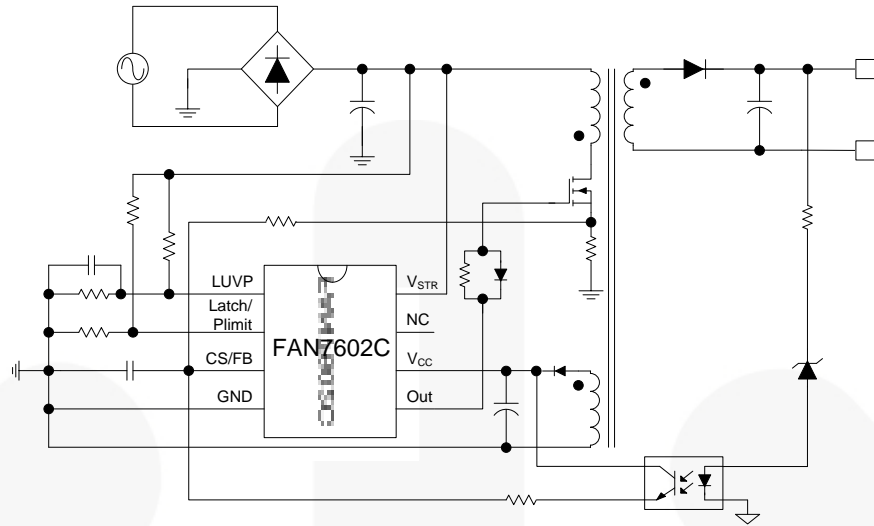

Figure 1. Typical Flyback Application

Internal Block Diagram

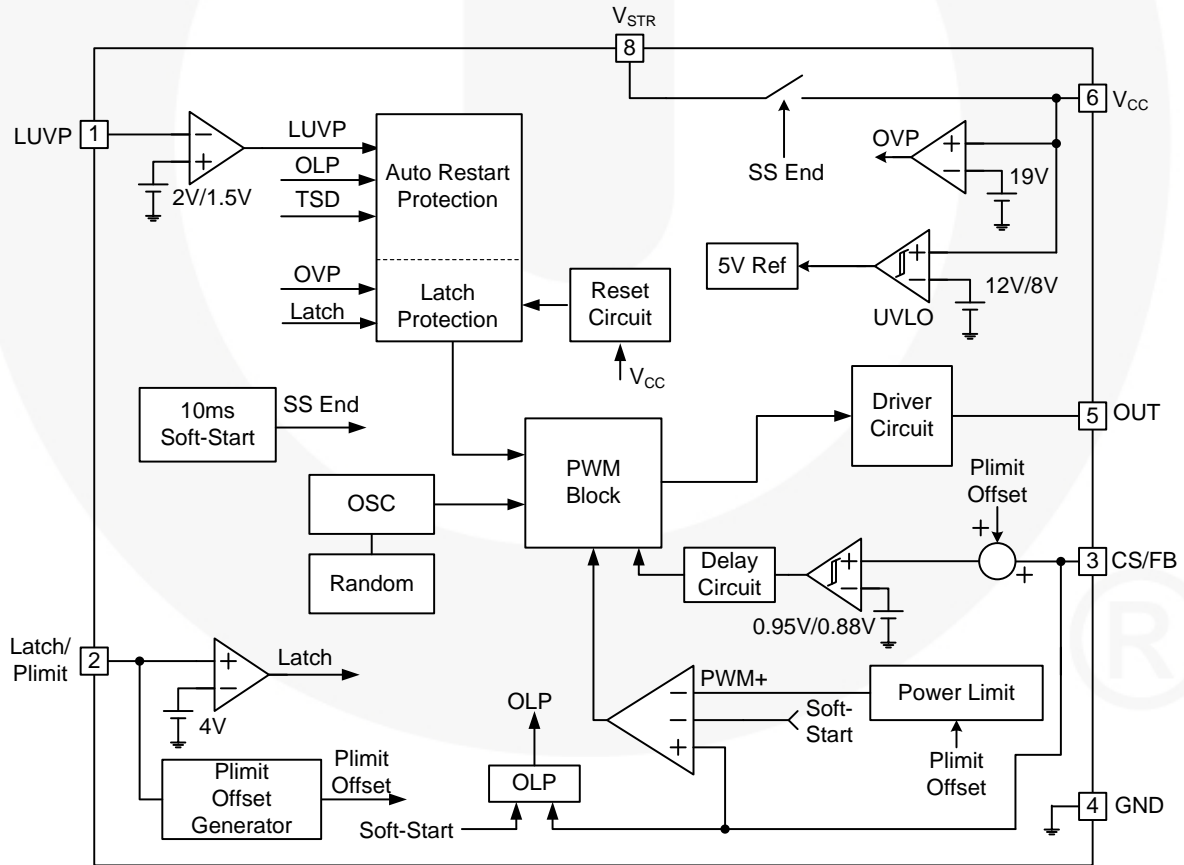

Figure 2. Functional Block Diagram

Pin Configuration

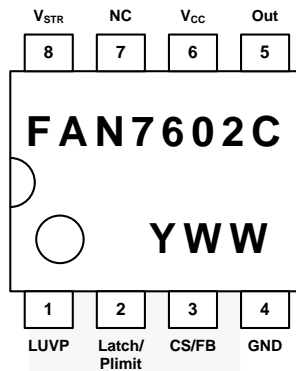

Figure 3. Pin Configuration (Top View)

Pin Definitions

Pin #	Name	Description
1	LUVP	Line Under-Voltage Protection Pin. This pin is used to protect the set when the input voltage is lower than the rated input voltage range.
2	Latch/Plimit	Latch Protection and Power Limit Pin. When the pin voltage exceeds 4 V, the latch protection works. The latch protection is reset when the V_{CC} voltage is lower than 5 V. For the power limit function, the OCP level decreases as the pin voltage increases.
3	CS/FB	Current Sense and Feedback Pin. This pin is used to sense the MOSFET current for the current mode PWM and OCP. The output voltage feedback information and the current sense information are added using an external RC filter.
4	GND	Ground Pin. This pin is used for the ground potential of all the pins. For proper operation, the signal ground and the power ground should be separated.
5	OUT	Gate Drive Output Pin. This pin is an output pin to drive an external MOSFET. The peak sourcing current is 450 mA and the peak sinking current is 600 mA. For proper operation, the stray inductance in the gate driving path must be minimized.
6	V_{CC}	Supply Voltage Pin. IC operating current and MOSFET driving current are supplied using this pin.
7	NC	No Connection.
8	V_{STR}	Startup Pin. This pin is used to supply IC operating current during IC startup. After startup, the internal JFET is turned off to reduce power loss.

Absolute Maximum Ratings

Stresses exceeding the absolute maximum ratings may damage the device. The device may not function or be operable above the recommended operating conditions and stressing the parts to these levels is not recommended. In addition, extended exposure to stresses above the recommended operating conditions may affect device reliability. The absolute maximum ratings are stress ratings only.

Symbol	Parameter	Min.	Max.	Unit
V_{CC}	Supply Voltage		25	V
I_O	Output Current	-600	+450	mA
$V_{CS/FB}$	CS/FB Input Voltage	-0.3	20.0	V
V_{LUVP}	LUVP Input Voltage	-0.3	10.0	V
V_{LATCH}	Latch/Plimit Input Voltage	-0.3	10.0	V
V_{STR}	V_{STR} Input Voltage		600	V
T_J	Junction Temperature		+150	°C
	Recommended Operating Junction Temperature	-40	+150	
T_{STG}	Storage Temperature Range	-55	+150	°C
P_D	Power Dissipation		1.2	W
ESD	Electrostatic Discharge Capability	Human Body Model, JESD22-A114		V
		Charged Device Model, JESD22-C101		

Thermal Impedance

Symbol	Parameter	Value	Unit
θ_{JA}	Thermal Resistance ⁽¹⁾ , Junction-to-Ambient	150	°C/W

Note:

- Regarding the test environment and PCB type, please refer to JESD51-2 and JESD51-10.

Electrical Characteristics

$V_{CC} = 14V$, $T_A = -25^{\circ}C \sim 125^{\circ}C$, unless otherwise specified.

Symbol	Parameter	Condition	Min.	Typ.	Max.	Unit
Startup Section						
I_{STR}	V_{STR} Startup Current	$V_{STR} = 30 V$, $T_A = 25^{\circ}C$	0.7	1.0	1.4	mA
Under Voltage Lock Out Section						
V_{th_start}	Start Threshold Voltage	V_{CC} Increasing	11	12	13	V
V_{th_stop}	Stop Threshold Voltage	V_{CC} Decreasing	7	8	9	V
HY_{UVLO}	UVLO Hysteresis		3.6	4.0	4.4	V
Supply Current Section						
I_{ST}	Startup Supply Current	$T_A = 25^{\circ}C$		250	320	μA
I_{CC}	Operating Supply Current	Output Not Switching		1.0	1.5	mA
Soft-Start Section						
t_{SS}	Soft-Start Time ⁽²⁾		5	10	15	ms
PWM Section						
f_{OSC}	Operating Frequency	$V_{CS/FB} = 0.2 V$, $T_A = 25^{\circ}C$	59	65	73	kHz
Δf_{OSC}	Frequency Fluctuation ⁽²⁾			± 3		kHz
$V_{CS/FB1}$	CS/FB Threshold Voltage	$T_A = 25^{\circ}C$	0.9	1.0	1.1	V
t_D	Propagation Delay to Output ⁽²⁾			100	150	ns
D_{MAX}	Maximum Duty Cycle		70	75	80	%
D_{MIN}	Minimum Duty Cycle				0	%
Burst Mode Section						
$V_{CS/FB2}$	Burst On Threshold Voltage	$T_A = 25^{\circ}C$	0.84	0.95	1.06	V
$V_{CS/FB3}$	Burst Off Threshold Voltage	$T_A = 25^{\circ}C$	0.77	0.88	0.99	V
Power Limit Section						
K_{Plimit}	Offset Gain	$V_{Latch/Plimit} = 2 V$, $T_A = 25^{\circ}C$	0.12	0.16	0.20	
Output Section						
V_{OH}	Output Voltage High	$T_A = 25^{\circ}C$, $I_{source} = 100 mA$	11.5	12.0	14.0	V
V_{OL}	Output Voltage Low	$T_A = 25^{\circ}C$, $I_{sink} = 100 mA$		1.0	2.5	V
t_R	Rising Time ⁽²⁾	$T_A = 25^{\circ}C$, $C_L = 1 nF$		45	150	ns
t_F	Falling Time ⁽²⁾	$T_A = 25^{\circ}C$, $C_L = 1 nF$		35	150	ns

Continued on the following page...

Electrical Characteristics (Continued)

$V_{CC} = 14V$, $T_A = -25^{\circ}C \sim 125^{\circ}C$, unless otherwise specified.

Symbol	Parameter	Condition	Min.	Typ.	Max.	Unit
Protection Section						
V_{LATCH}	Latch Voltage		3.6	4.0	4.4	V
t_{OLP}	Overload Protection Time ⁽²⁾		20	22	24	ms
t_{OLP_ST}	Overload Protection Time at Startup		30	37	44	ms
V_{OLP}	Overload Protection Level			0	0.1	V
$V_{LUVPOff}$	Line Under-Voltage Protection On to Off	$T_A = 25^{\circ}C$	1.9	2.0	2.1	V
V_{LUVPOn}	Line Under-Voltage Protection Off to On	$T_A = 25^{\circ}C$	1.4	1.5	1.6	V
V_{OVP}	Over-Voltage Protection	$T_A = 25^{\circ}C$	18	19	20	V
T_{SD}	Shutdown Temperature ⁽²⁾			170		$^{\circ}C$
HYS				60		$^{\circ}C$

Note:

- These parameters, although guaranteed, are not 100% tested in production.



Typical Performance Characteristics

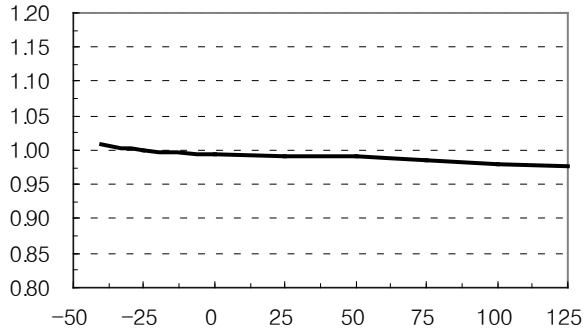

Figure 4. Start Threshold Voltage vs. Temperature

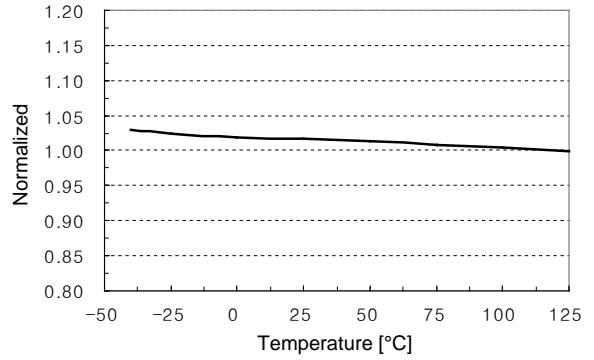

Figure 5. Stop Threshold Voltage vs. Temperature

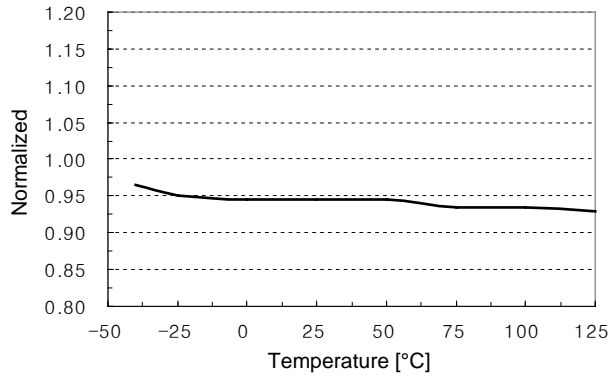

Figure 6. UVLO Hysteresis vs. Temperature

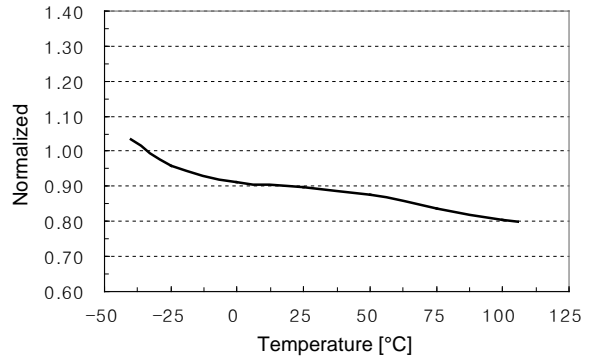

Figure 7. Startup Threshold Current vs. Temperature

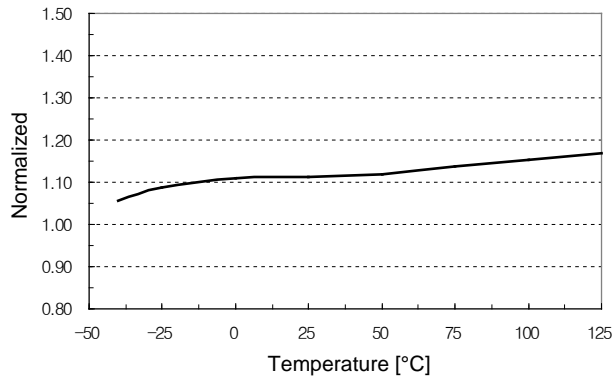

Figure 8. Operating Supply Current vs. Temperature

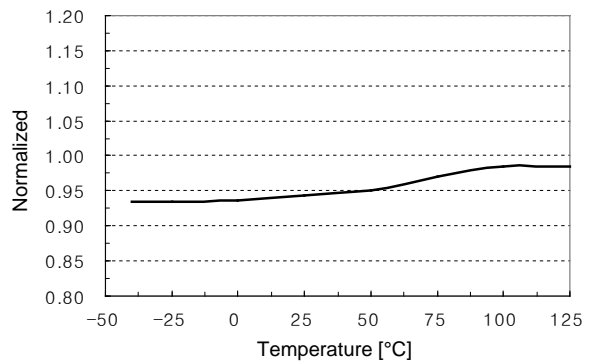

Figure 9. V_{STR} Startup Current vs. Temperature

Typical Performance Characteristics (Continued).

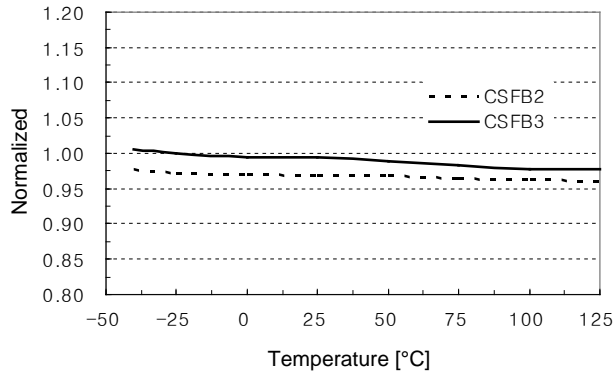

Figure 10. Burst On/Off Voltage vs. Temperature

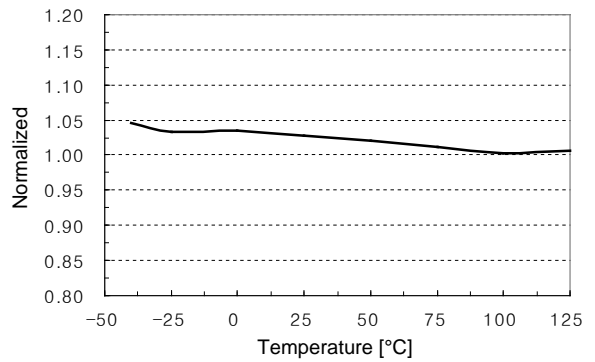

Figure 11. Operating Frequency vs. Temperature

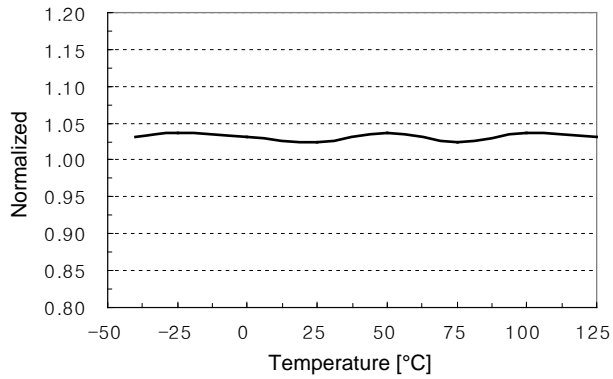

Figure 12. Offset Gain vs. Temperature

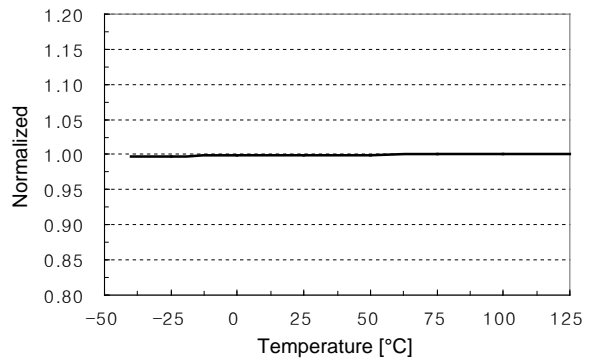

Figure 13. Maximum Duty Cycle vs. Temperature

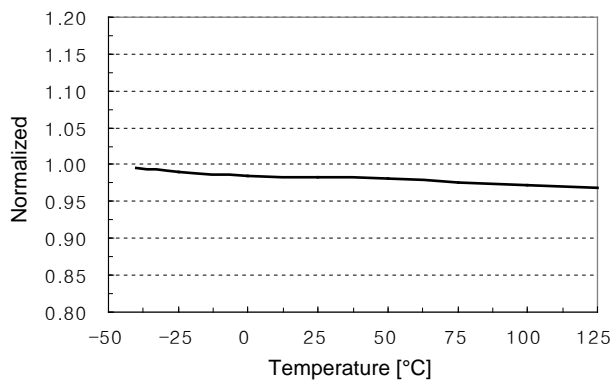

Figure 14. OVP Voltage vs. Temperature

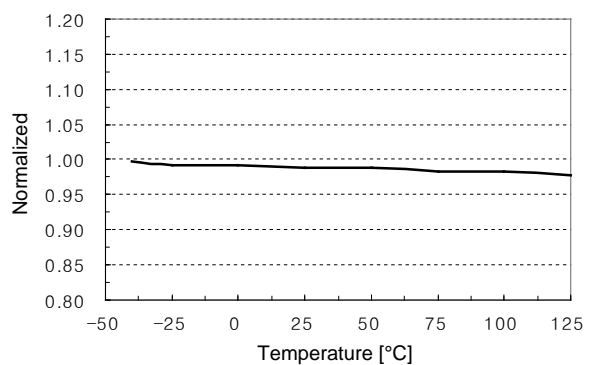

Figure 15. Latch Voltage vs. Temperature

Typical Performance Characteristics (Continued)

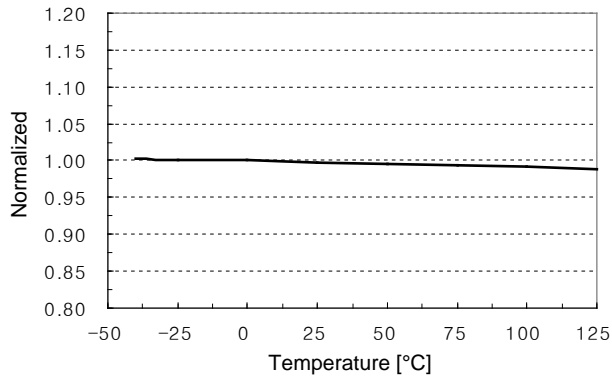

Figure 16. LUVP On-to-Off Voltage vs. Temperature

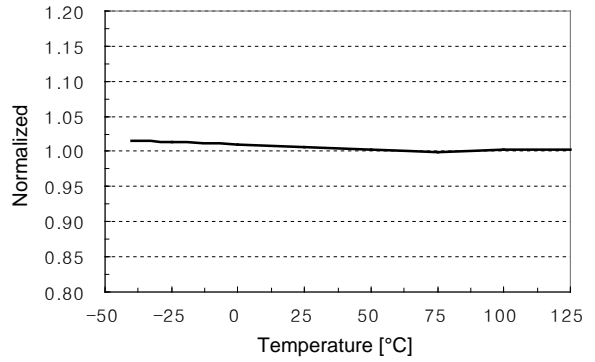

Figure 17. LUVP Off-to-On Voltage vs. Temperature

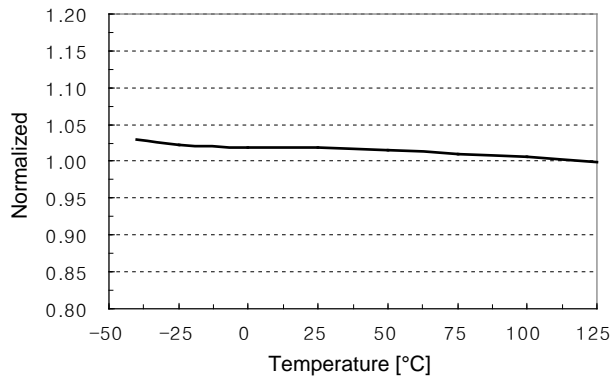

Figure 18. CS/FB Threshold Voltage vs. Temperature

Application Information

1. Startup Circuit and Soft-Start Block

The FAN7602C contains a startup switch to reduce the power loss of the external startup circuit of the conventional PWM converters. The internal startup circuit charges the V_{CC} capacitor with 0.9 mA current source if the AC line is connected. The startup switch is turned off 15 ms after IC starts up, as shown in Figure 19. The soft-start function starts when the V_{CC} voltage reaches the start threshold voltage of 12 V and ends when the internal soft-start voltage reaches 1 V. The internal startup circuit starts charging the V_{CC} capacitor again if the V_{CC} voltage is lowered to the minimum operating voltage, 8 V. The UVLO block shuts down the output drive circuit and some blocks to reduce the IC operating current and the internal soft-start voltage drops to zero. If the V_{CC} voltage reaches the start threshold voltage, the IC starts switching again and the soft-start block works as well.

During the soft-start, pulse-width modulated (PWM) comparator compares the CS/FB pin voltage with the soft-start voltage. The soft-start voltage starts from 0.5 V and the soft-start ends when it reaches 1 V and the soft-start time is 10 ms. The startup switch is turned off when the soft-start voltage reaches 1.3 V.

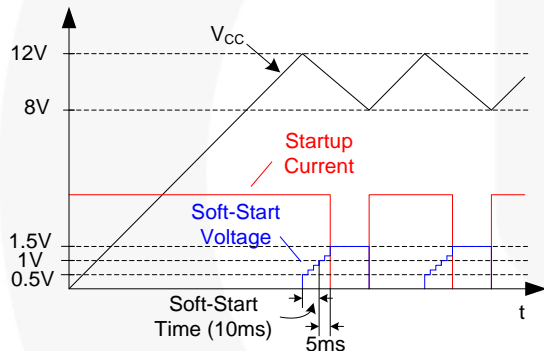

Figure 19. Startup Current and V_{CC} Voltage

2. Oscillator Block

The oscillator frequency is set internally and FAN7602C has a random frequency fluctuation function.

Fluctuation of the switching frequency of a switched power supply can reduce EMI by spreading the energy over a wider frequency range than the bandwidth measured by the EMI test equipment. The amount of EMI reduction is directly related to the range of the frequency variation. The range of frequency variation is fixed internally; however, its selection is randomly chosen by the combination of external feedback voltage and internal free-running oscillator. This randomly chosen switching frequency effectively spreads the EMI noise nearby switching frequency and allows the use of a cost-effective inductor instead of an AC input line filter to satisfy the world-wide EMI requirements.

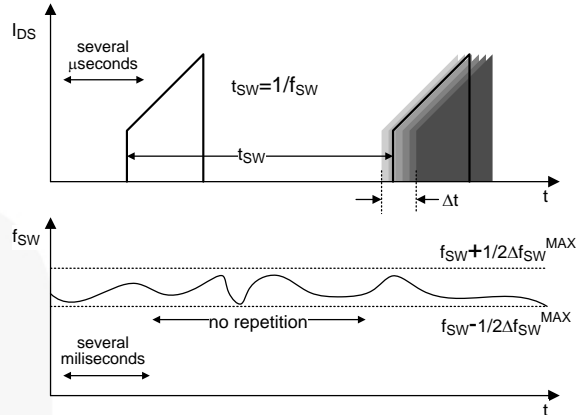

Figure 20. Frequency Fluctuation Waveform

3. Current Sense and Feedback Block

The FAN7602C performs the current sensing for the current mode PWM and the output voltage feedback with only one pin, pin 3. To achieve the two functions with one pin, an internal Leading-Edge Blanking (LEB) circuit to filter the current sense noise is not included because the external RC filter is necessary to add the output voltage feedback information and the current sense information.

Figure 21 shows the current sense and feedback circuits. R_S is the current sense resistor to sense the switch current. The current sense information is filtered by an RC filter composed of R_F and C_F . According to the output voltage feedback information, I_{FB} charges or stops charging C_F to adjust the offset voltage. If I_{FB} is zero, C_F is discharged through R_F and R_S to lower the offset voltage.

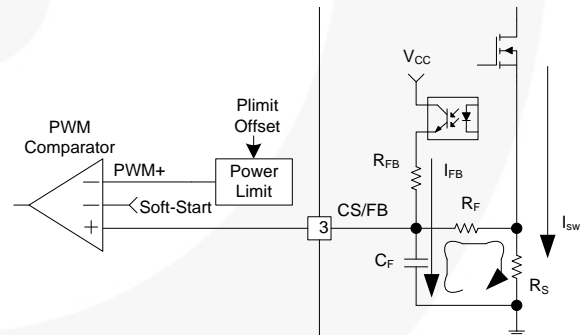

Figure 21. Current Sense and Feedback Circuits

Figure 22 shows typical voltage waveforms of the CS/FB pin. The current sense waveform is added to the offset voltage, as shown in the Figure 22. The CS/FB pin voltage is compared with PWM that is 1 V - Plimit offset. If the CS/FB voltage meets PWM+, the output drive is shut off. If the feedback offset voltage is LOW, the switch on-time is increased. If the feedback offset voltage is HIGH, the switch on-time is decreased. In this way, the duty cycle is controlled according to the output load condition. Generally, the maximum output power increases as input voltage increases because the current slope during switch on-time increases.

To limit the output power of the converter constantly, the power limit function is included in FAN7602C. Sensing the converter input voltage through the Latch/Plimit pin, the Plimit offset voltage is subtracted from 1 V. As shown in Figure 22, the Plimit offset voltage is subtracted from 1 V and the switch on-time decreases as the Plimit offset voltage increases. If the converter input voltage increases, the switch on-time decreases, keeping the output power constant. The offset voltage is proportional to the Latch/Plimit pin voltage and the gain is 0.16. If the Latch/Plimit voltage is 1 V, the offset voltage is 0.16 V.

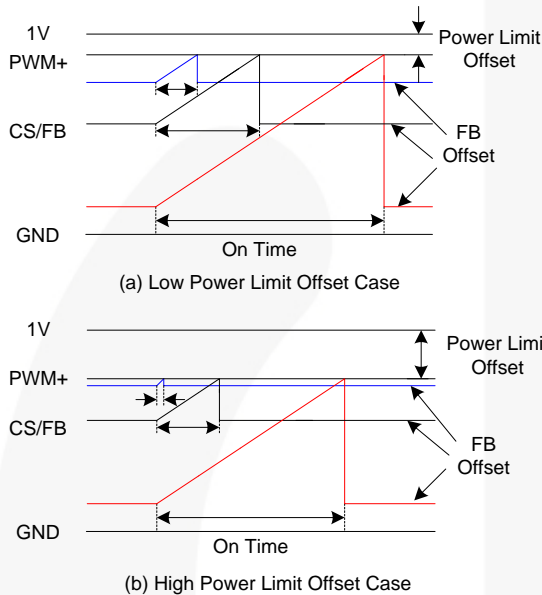

Figure 22. CS/FB Pin Voltage Waveforms

4. Burst-Mode Block

The FAN7602C contains the burst-mode block to reduce the power loss at a light-load and no load. A hysteresis comparator senses the offset voltage of the Burst+ for the burst mode, as shown in Figure 23. The Burst+ is the sum of the CS/FB voltage and Plimit offset voltage. The FAN7602C enters the burst mode when the offset voltage of the Burst+ is higher than 0.95 V and exits the burst mode when the offset voltage is lower than 0.88 V. The offset voltage is sensed during the switch off time.

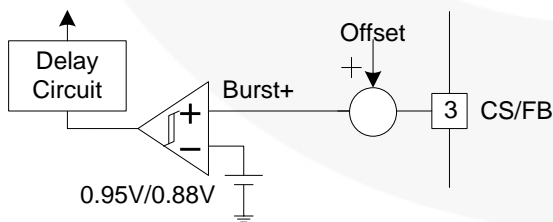

Figure 23. Burst-Mode Block

5. Protection Block

The FAN7602C contains several protection functions to improve system reliability.

5.1 Overload Protection (OLP)

The FAN7602C contains the overload protection function. If the output load is higher than the rated output current, the output voltage drops and the feedback error amplifier is saturated. The offset of the CS/FB voltage representing the feedback information is almost zero. As shown in Figure 24, the CS/FB voltage is compared with 50 mV reference when the internal clock signal is HIGH and, if the voltage is lower than 50 mV, the OLP timer starts counting. If the OLP condition persists for 22 ms, the timer generates the OLP signal. The protection is reset by the UVLO. The OLP block is enabled after the soft-start finishes.

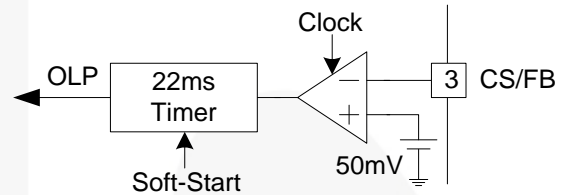

Figure 24. Overload Protection Circuit

5.2 Line Under-Voltage Protection

If the input voltage of the converter is lower than the minimum operating voltage, the converter input current increases too much, causing components failure. Therefore, if the input voltage is LOW, the converter should be protected. The LUVV circuit senses the input voltage using the LUVV pin and, if this voltage is lower than 2 V, the LUVV signal is generated. The comparator has 0.5 V hysteresis. If the LUVV signal is generated, the output drive block is shut down, the output voltage feedback loop is saturated, and the OLP works if the LUVV condition persists more than 22 ms.

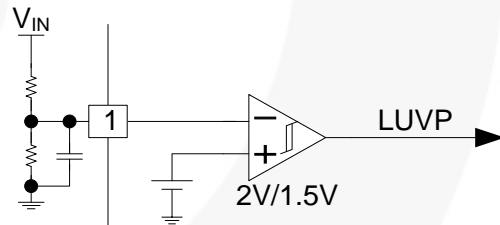

Figure 25. Line UVP Circuit

5.3 Latch Protection

The latch protection is provided to protect the system against abnormal conditions using the Latch/Plimit pin. The Latch/Plimit pin can be used for the output over-voltage protection and/or other protections. If the Latch/Plimit pin voltage is made higher than 4 V by an external circuit, the IC is shut down. The latch protection is reset when the V_{CC} voltage is lower than 5 V.

5.4 Over-Voltage Protection (OVP)

If the V_{CC} voltage reaches 19 V, the IC shuts down and the OVP protection is reset when the V_{CC} voltage is lower than 5 V.

6. Output Drive Block

The FAN7602C contains a single totem-pole output stage to drive a power MOSFET. The drive output is capable of up to 450 mA sourcing current and 600 mA

sinking current with typical rise and fall time of 45 ns and 35 ns, respectively, with a 1 nF load.

Typical Application Circuit

Application	Output Power	Input Voltage	Output Voltage
Adaptor	48 W	Universal Input (85 ~ 265 V _{AC})	12V

Features

- Low stand-by power (<0.15 W at 265 V_{AC})
- Constant output power control

Key Design Notes

- All the IC-related components should be placed close to IC, especially C107 and C110.
- If R106 value is too low, there can be subharmonic oscillation.
- R109 should be designed carefully to make the V_{CC} voltage higher than 8 V when the input voltage is 265 V_{AC} at no load.
- R110 should be designed carefully to make the V_{CC} voltage lower than OVP level when the input voltage is 85 V_{AC} at full load.
- R103 should be designed to keep the MOSFET V_{DS} voltage lower than maximum rating when the output is shorted.



1. Schematic

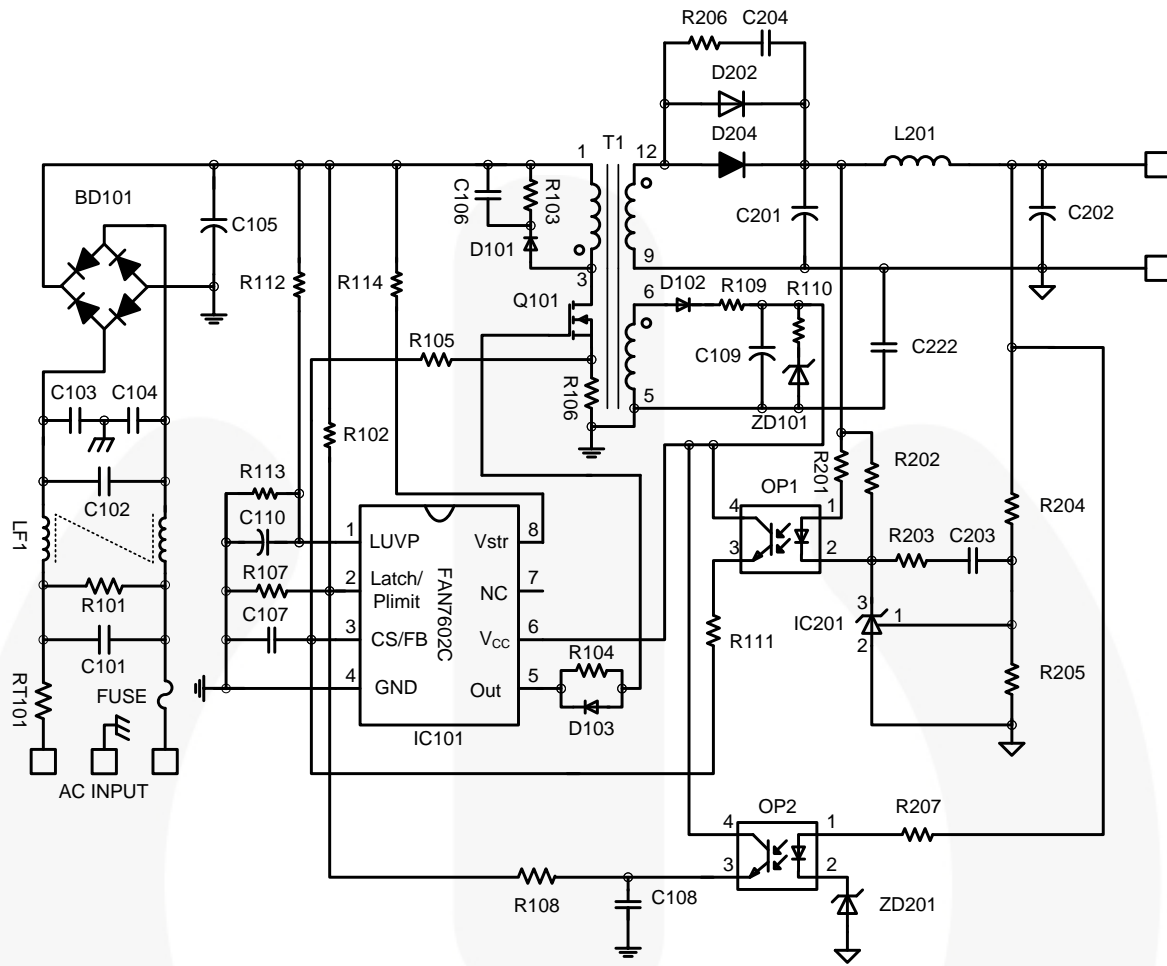

Figure 26. Schematic

2. Inductor Schematic Diagram

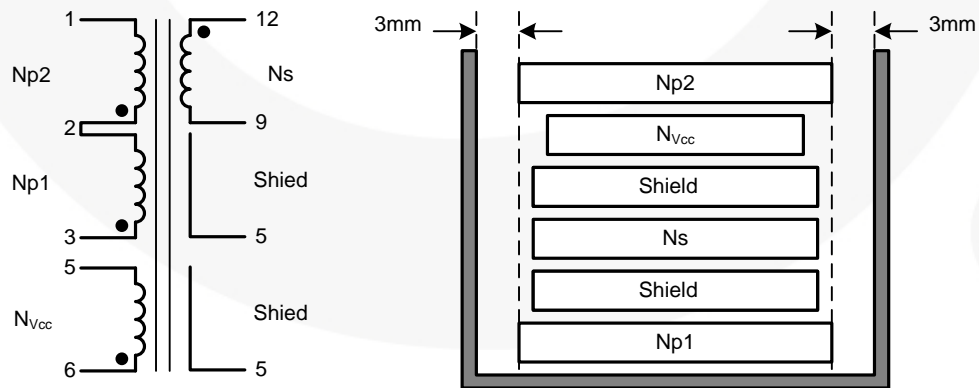

Figure 27. Inductor Schematic Diagram

3. Winding Specification

No.	Pin (S → F)	Wire	Turns	Winding Method
N _{p1}	3 → 2	0.3 ^ϕ x 2	31	Solenoid Winding
Insulation: Polyester Tape t = 0.03 mm, 2-Layer				
Shield	5	Copper Tape	0.9	Not Shorted
Insulation: Polyester Tape t = 0.03 mm, 2-Layer				
N _s	12 → 9	0.65 ^ϕ x 3	10	Solenoid Winding
Insulation: Polyester Tape t = 0.03 mm, 2-Layer				
Shield	5	Copper Tape	0.9	Not Shorted
Insulation: Polyester Tape t = 0.03 mm, 2-Layer				
N _{Vcc}	6 → 5	0.2 ^ϕ x 1	10	Solenoid Winding
Insulation: Polyester Tape t = 0.03 mm, 2-Layer				
N _{p2}	2 → 1	0.3 ^ϕ x 2	31	Solenoid Winding
Outer Insulation: Polyester Tape t = 0.03 mm, 2-Layer				

4. Electrical Characteristics

	Pin	Specification	Remarks
Inductance	1 - 3	607 μH	100 kHz, 1 V
Inductance	1 - 3	15 μH	9 - 12 Shorted

5. Core & Bobbin

- Core: EER2828
- Bobbin: EER2828
- Ae(mm²): 82.1

6. Demo Circuit Part List

Part	Value	Note	Part	Value	Note
Fuse			Capacitor		
FUSE	1 A/250 V		C101	220 nF / 275 V	Box Capacitor
NTC			C102	150 nF / 275 V	Box Capacitor
RT101	5D-9		C103, C104	102 / 1 kV	Ceramic
Resistor			C105	150 μ F / 400 V	Electrolytic
R102, R112	10 M Ω	1/4 W	C106	103 / 630 V	Film
R103	56 k Ω	1/2 W	C107	271	Ceramic
R104	150 Ω	1/4 W	C108	103	Ceramic
R105	1 k Ω	1/4 W	C109	22 μ F / 25 V	Electrolytic
R106	0.5 Ω	1/2 W	C110	473	Ceramic
R107	56 k Ω	1/4 W	C201, C202	1000 μ F / 25 V	Electrolytic
R108	10 k Ω	1/4 W	C203	102	Ceramic
R109	0 Ω	1/4 W	C204	102	Ceramic
R110	1 k Ω	1/4 W	C222	222 / 1 kV	Ceramic
R111	6 k Ω	1/4 W	MOSFET		
R113	180 k Ω	1/4 W	Q101	FQPF8N60C	Fairchild Semiconductor
R114	50 k Ω	1/4 W	Diode		
R201	1.5 k Ω	1/4 W	D101, D102	UF4007	Fairchild Semiconductor
R202	1.2 k Ω	1/4 W	D103	1N5819	Fairchild Semiconductor
R203	20 k Ω	1/4 W	D202, D204	FYPF2010DN	Fairchild Semiconductor
R204	27 k Ω	1/4 W	ZD101, ZD201	1N4744	Fairchild Semiconductor
R205	7 k Ω	1/4 W	BD101	KBP06	Fairchild Semiconductor
R206	10 Ω	1/2 W	TNR		
R207	10 k Ω	1/4 W	R101	471	470 V
IC			Filter		
IC101	FAN7602C	Fairchild Semiconductor	LF101	23 mH	0.8 A
IC201	KA431	Fairchild Semiconductor	L201	10 μ H	4.2 A
OP1, OP2	H11A817B	Fairchild Semiconductor			

7. PCB Layout

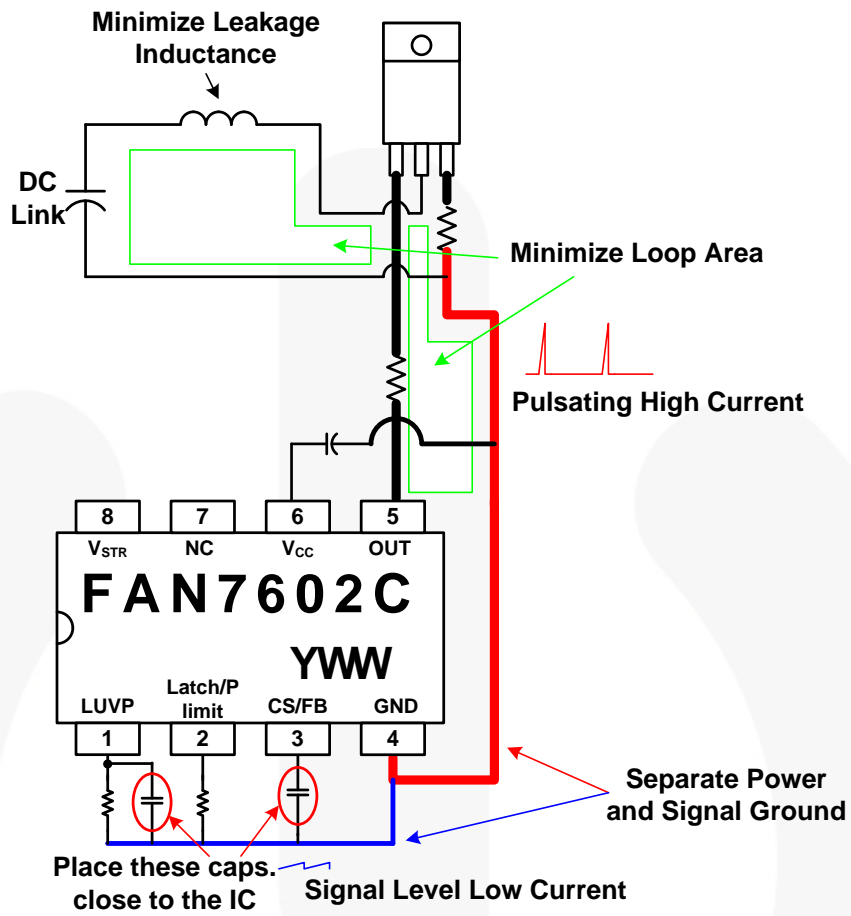
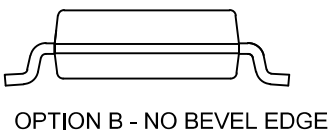

Figure 28. PCB Layout Recommendations

8. Performance Data

	85 V _{AC}	110 V _{AC}	220 V _{AC}	265 V _{AC}
Input Power at No Load	72 mW	76 mW	92 mW	107 mW
Input Power at 0.5 W Load	760 mW	760 mW	785 mW	805 mW
OLP Point	4.73 A	5.07 A	5.11 A	4.91 A



NOTES:

- A) THIS PACKAGE CONFORMS TO JEDEC MS-012, VARIATION AA.
- B) ALL DIMENSIONS ARE IN MILLIMETERS.
- C) DIMENSIONS DO NOT INCLUDE MOLD FLASH OR BURRS.
- D) LANDPATTERN STANDARD: SOIC127P600X175-8M
- E) DRAWING FILENAME: M08Arev16





TRADEMARKS

The following includes registered and unregistered trademarks and service marks, owned by Fairchild Semiconductor and/or its global subsidiaries, and is not intended to be an exhaustive list of all such trademarks.

AccuPower™
AttitudeEngine™
Awinda®
AX-CAP®*
BitSiC™
Build it Now™
CorePLUS™
CorePOWER™
CROSSVOL™
CTL™
Current Transfer Logic™
DEUXPEED®
Dual Cool™
EcoSPARK®
EfficientMax™
ESBC™
F®
Fairchild®
Fairchild Semiconductor®
FACT Quiet Series™
FACT®
FastvCore™
FETBench™
FPS™

F-PFS™
FRFET®
Global Power Resource™
GreenBridge™
Green FPS™
Green FPS™ e-Series™
Gmax™
GTO™
IntelliMAX™
ISOPLANAR™
Making Small Speakers Sound Louder and Better™
MegaBuck™
MICROCOUPLER™
MicroFET™
MicroPak™
MicroPak2™
MillerDrive™
MotionMax™
MotionGrid®
MTi®
MTx®
MVN®
mWSaver®
OptoHiT™
OPTOLOGIC®

OPTOPLANAR®
Power Supply WebDesigner™
PowerTrench®
PowerXS™
Programmable Active Droop™
QFET®
QS™
Quiet Series™
RapidConfigure™
Saving our world, 1mW/W/kW at a time™
SignalWise™
SmartMax™
SMART START™
Solutions for Your Success™
SPM®
STEALTH™
SuperFET®
SuperSOT™-3
SuperSOT™-6
SuperSOT™-8
SupreMOS®
SyncFET™
Sync-Lock™

SYSTEM GENERAL®
TinyBoost®
TinyBuck®
TinyCalc™
TinyLogic®
TINYOPTO™
TinyPower™
TinyPWM™
TinyWire™
TranSiC™
TriFault Detect™
TRUECURRENT®*
µSerDes™
SerDes®
UHC®
Ultra FRFET™
UniFET™
VCX™
VisualMax™
VoltagePlus™
XS™
Xsens™
仙童®

* Trademarks of System General Corporation, used under license by Fairchild Semiconductor.

DISCLAIMER

FAIRCHILD SEMICONDUCTOR RESERVES THE RIGHT TO MAKE CHANGES WITHOUT FURTHER NOTICE TO ANY PRODUCTS HEREIN TO IMPROVE RELIABILITY, FUNCTION, OR DESIGN. TO OBTAIN THE LATEST, MOST UP-TO-DATE DATASHEET AND PRODUCT INFORMATION, VISIT OUR WEBSITE AT [HTTP://WWW.FAIRCHILDSEMI.COM](http://www.fairchildsemi.com). FAIRCHILD DOES NOT ASSUME ANY LIABILITY ARISING OUT OF THE APPLICATION OR USE OF ANY PRODUCT OR CIRCUIT DESCRIBED HEREIN; NEITHER DOES IT CONVEY ANY LICENSE UNDER ITS PATENT RIGHTS, NOR THE RIGHTS OF OTHERS. THESE SPECIFICATIONS DO NOT EXPAND THE TERMS OF FAIRCHILD'S WORLDWIDE TERMS AND CONDITIONS, SPECIFICALLY THE WARRANTY THEREIN, WHICH COVERS THESE PRODUCTS.

AUTHORIZED USE

Unless otherwise specified in this data sheet, this product is a standard commercial product and is not intended for use in applications that require extraordinary levels of quality and reliability. This product may not be used in the following applications, unless specifically approved in writing by a Fairchild officer: (1) automotive or other transportation, (2) military/aerospace, (3) any safety critical application – including life critical medical equipment – where the failure of the Fairchild product reasonably would be expected to result in personal injury, death or property damage. Customer's use of this product is subject to agreement of this Authorized Use policy. In the event of an unauthorized use of Fairchild's product, Fairchild accepts no liability in the event of product failure. In other respects, this product shall be subject to Fairchild's Worldwide Terms and Conditions of Sale, unless a separate agreement has been signed by both Parties.

ANTI-COUNTERFEITING POLICY

Fairchild Semiconductor Corporation's Anti-Counterfeiting Policy. Fairchild's Anti-Counterfeiting Policy is also stated on our external website, www.fairchildsemi.com, under Terms of Use

Counterfeiting of semiconductor parts is a growing problem in the industry. All manufacturers of semiconductor products are experiencing counterfeiting of their parts. Customers who inadvertently purchase counterfeit parts experience many problems such as loss of brand reputation, substandard performance, failed applications, and increased cost of production and manufacturing delays. Fairchild is taking strong measures to protect ourselves and our customers from the proliferation of counterfeit parts. Fairchild strongly encourages customers to purchase Fairchild parts either directly from Fairchild or from Authorized Fairchild Distributors who are listed by country on our web page cited above. Products customers buy either from Fairchild directly or from Authorized Fairchild Distributors are genuine parts, have full traceability, meet Fairchild's quality standards for handling and storage and provide access to Fairchild's full range of up-to-date technical and product information. Fairchild and our Authorized Distributors will stand behind all warranties and will appropriately address any warranty issues that may arise. Fairchild will not provide any warranty coverage or other assistance for parts bought from Unauthorized Sources. Fairchild is committed to combat this global problem and encourage our customers to do their part in stopping this practice by buying direct or from authorized distributors.

PRODUCT STATUS DEFINITIONS

Definition of Terms

Datasheet Identification	Product Status	Definition
Advance Information	Formative / In Design	Datasheet contains the design specifications for product development. Specifications may change in any manner without notice.
Preliminary	First Production	Datasheet contains preliminary data; supplementary data will be published at a later date. Fairchild Semiconductor reserves the right to make changes at any time without notice to improve design.
No Identification Needed	Full Production	Datasheet contains final specifications. Fairchild Semiconductor reserves the right to make changes at any time without notice to improve the design.
Obsolete	Not In Production	Datasheet contains specifications on a product that is discontinued by Fairchild Semiconductor. The datasheet is for reference information only.