

FAN8705

5 Channel DSC Motor Driver

Features

- n Built in power save function
- n Built in UVLO function.
- n Constant current drive for shutter.
- n Low Ron resistance (1.1 Ω @ 0.2A)
- n Constant voltage drive for CH1~CH3.
- n Pseudo sinewave control for AF.
- n Three input 2-2 phase control for AF
- n Built in short circuit protection.
- n TSD protection.

Applications

- n DSC, Mobile phone camera

Description

The FAN8705 is a DSC lens motor driver and it's consist of constant current and constant voltage drive blocks suitable for shutter, single iris, auto-focus and zoom motor drive.

40MLP5X5

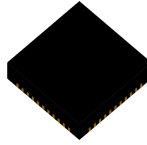

Ordering Information

Device	Package	Operating Temp.
FAN8705	40-MLP	-25°C ~ 80°C

Pin Assignments

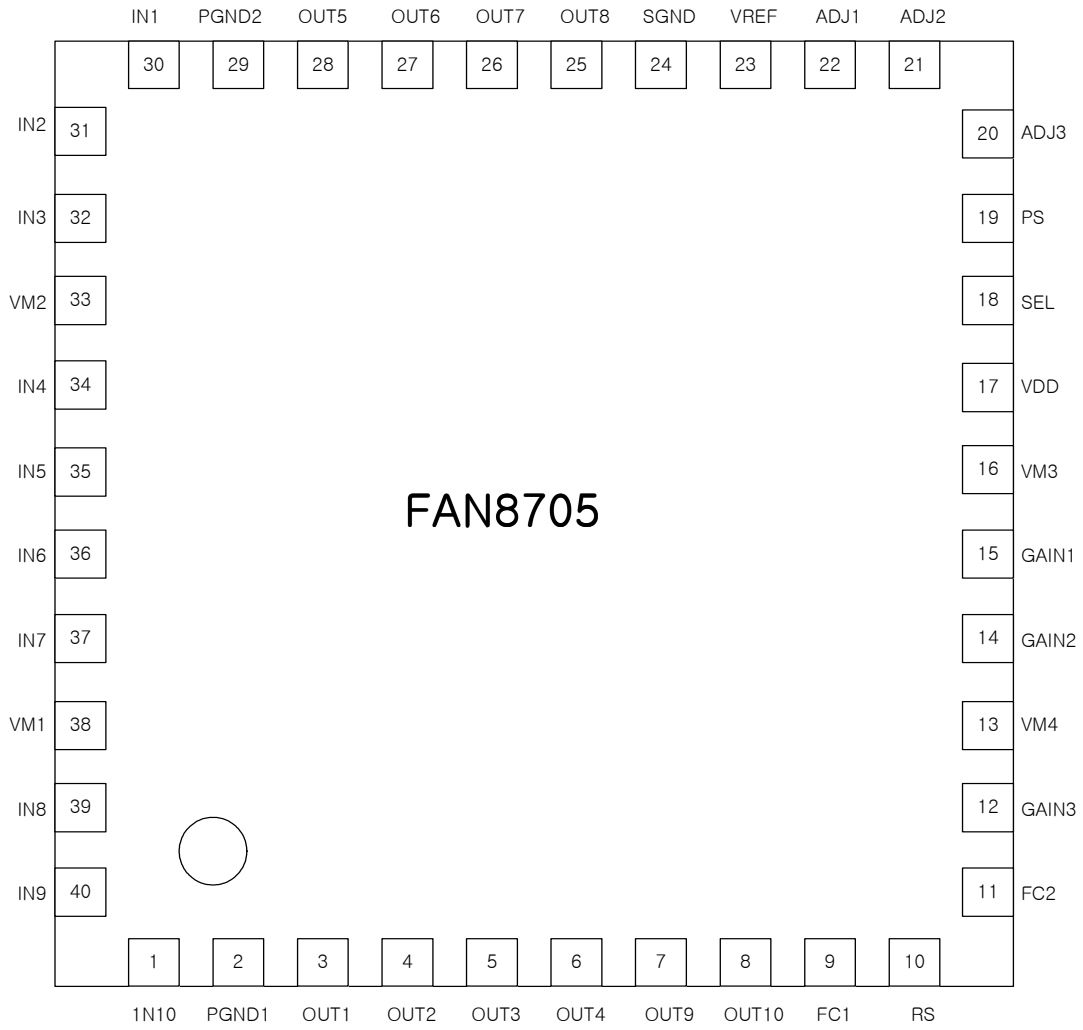

www.DataSheet4U.com

Pin Definitions

Pin Number	Pin Name	I/O	Pin Function Description	Remark
1	IN10	I	Logic input 10	
2	PGND1	P	Power ground 1 for Out 1~4	
3	OUT1	A	Motor output 1	
4	OUT2	A	Motor output 2	
5	OUT3	A	Motor output 3	
6	OUT4	A	Motor output 4	
7	OUT9	A	Motor output 9	
8	OUT10	A	Motor output 10	
9	FC1	A	Compensation 1	
10	RS	A	Motor current sensing for Out9~10	
11	FC2	A	Compensation 2	
12	GAIN3	I	Gain select for Out9~10	
13	VM4	P	Power supply for Out9~10	
14	GAIN2	I	Gain select for Out5~6	
15	GAIN1	I	Gain select for Out1~4	
16	VM3	P	Power supply for Out7~8	
17	VDD	P	Logic power supply	
18	SEL	I	CH1,2 logic input change	
19	PS	I	Power save	
20	ADJ3	A	Out9~10 current adjust	
21	ADJ2	A	Out5~6 voltage adjust	
22	ADJ1	A	Out1~4 voltage adjust	
23	VREF	A	Reference output	
24	SGND	P	Signal ground	
25	OUT8	A	Motor output 8	
26	OUT7	A	Motor output 7	
27	OUT6	A	Motor output 6	
28	OUT5	A	Motor output 5	
29	PGND2	P	Power ground 2 for Out5~8	
30	IN1	I	Logic input 1	
31	IN2	I	Logic input 2	
32	IN3	I	Logic input 3	
33	VM2	P	Power supply for Out5~6	
34	IN4	I	Logic input 4	
35	IN5	I	Logic input 5	
36	IN6	I	Logic input 6	
37	IN7	I	Logic input 7	
38	VM1	P	Power supply for Out1~4	
39	IN8	I	Logic input 8	
40	IN9	I	Logic input 9	

Block Diagram

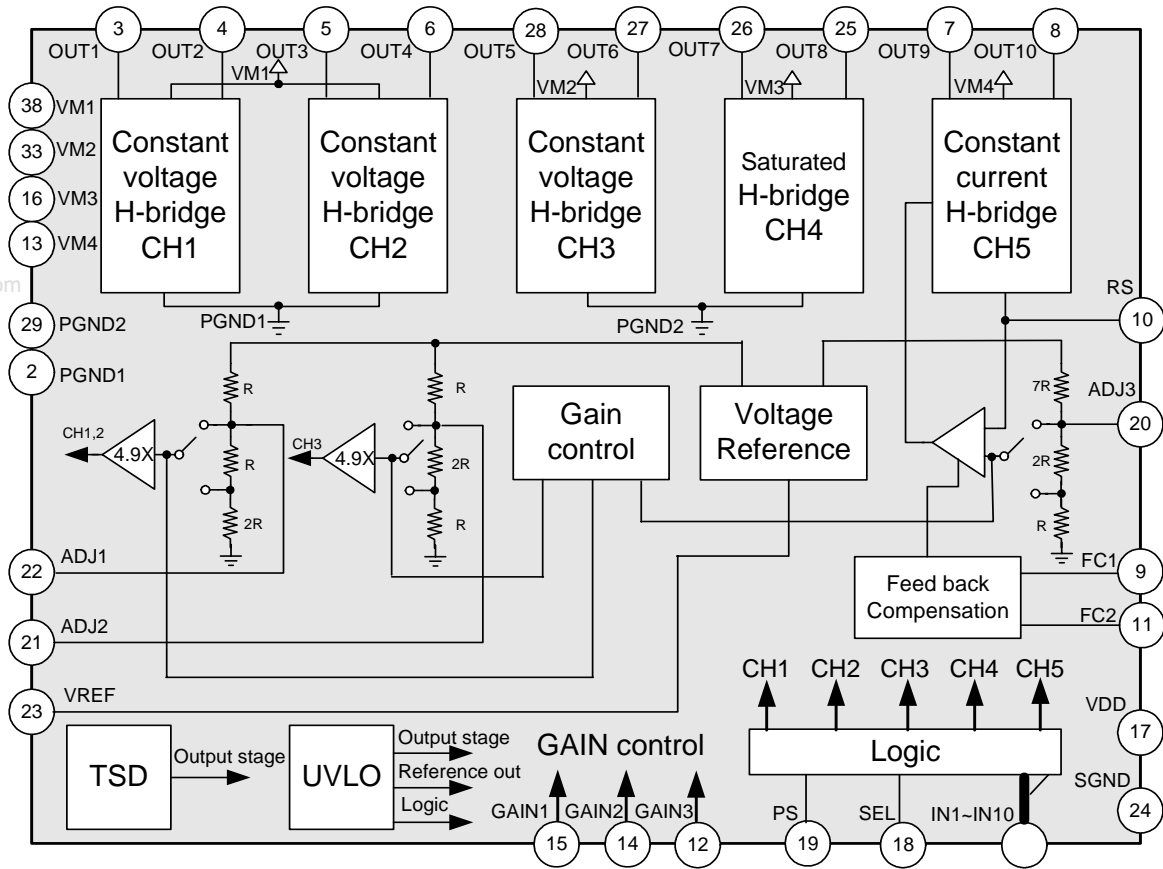

Equivalent Circuits

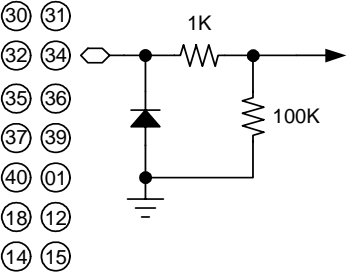
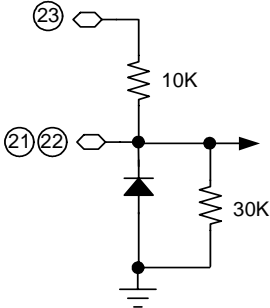
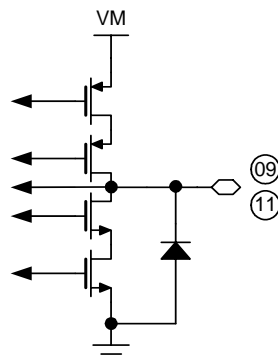
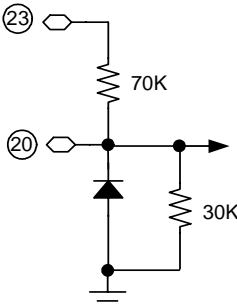
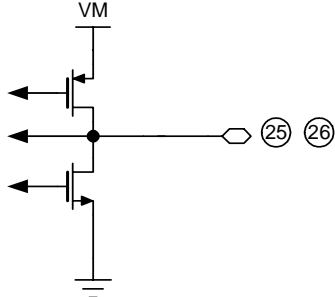
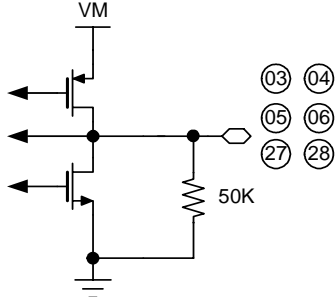
Logic Input	ADJ1, ADJ2
 <p>Logic Input equivalent circuit diagram showing a 1K resistor connected to pins 30, 31, 32, 34, 35, 36, 37, 39, 40, 01, 18, 12, 14, and 15. A diode is connected to ground, and a 100K resistor is connected to ground.</p>	 <p>ADJ1, ADJ2 equivalent circuit diagram showing a 10K resistor connected to pin 23, a diode connected to ground, and a 30K resistor connected to ground. Pins 21 and 22 are also shown.</p>
FC1, FC2	ADJ3
 <p>FC1, FC2 equivalent circuit diagram showing a VM supply, a diode connected to ground, and pins 09 and 11.</p>	 <p>ADJ3 equivalent circuit diagram showing a 70K resistor connected to pin 23, a diode connected to ground, and a 30K resistor connected to ground. Pin 20 is also shown.</p>
OUT7, OUT8	OUT1 ~ 6
 <p>OUT7, OUT8 equivalent circuit diagram showing a VM supply and pins 25 and 26.</p>	 <p>OUT1 ~ 6 equivalent circuit diagram showing a VM supply, a diode connected to ground, a 50K resistor connected to ground, and pins 03, 04, 05, 06, 27, and 28.</p>

Equivalent Circuits

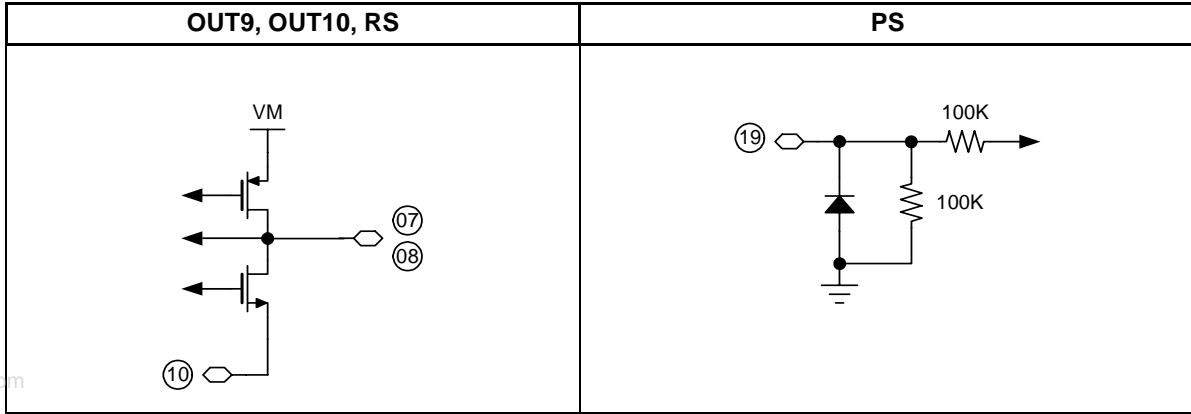

www.DataSheet4U.com

Absolute Maximum Ratings (Ta = 25°C)

Parameter	Symbol	Value	Unit
Maximum power supply voltage	VDDMAX, VM MAX	5.5	V
Thermal resistance	Rja	100/52	°C/W
Maximum power dissipation	PD MAX	1.25/2.4	W
Maximum output voltage	VOM AX	6.5	V
Maximum output current	IOM AX	0.8	A
Operating temperature	TOPR	-25 ~ 85	°C
Storage temperature	TSTG	-55 ~ 150	°C

note

- Should not exceed PD or ASO value.
- Refer: EIA/JESD 51-2 & EIA/JESD 51-3 & EIA/JESD 51-5 & EIA/JESD 51-7
- Case 1: Single layer PCB with 1 signal plane only, PCB size 76mm × 114mm × 1.6mm.
- Case 2: Multi layer PCB with 1 signal, 1 power and 1 ground planes, PCB size 76mm × 114mm × 1.6mm, Cu plane sizes for power and ground 74mm × 74mm × 0.035mm.

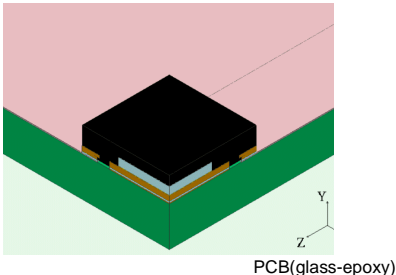
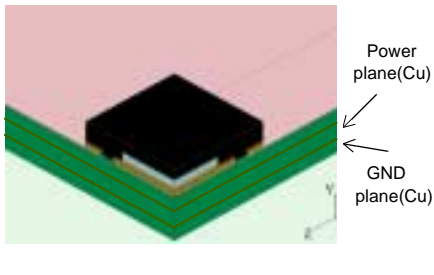
Case 1	Case 2	Remark
 <p>Pd=1.25W</p>	 <p>Pd=1.8W</p>	<p>Pd is measured base on the JEDEC/STD(JESD 51-2)</p>

Recommended Operating Conditions (Ta = 25°C)

Parameter	Symbol	Min.	Typ.	Max.	Unit
Supply voltage	VDD	2.4	-	5.0	V

Power Dissipation Curve

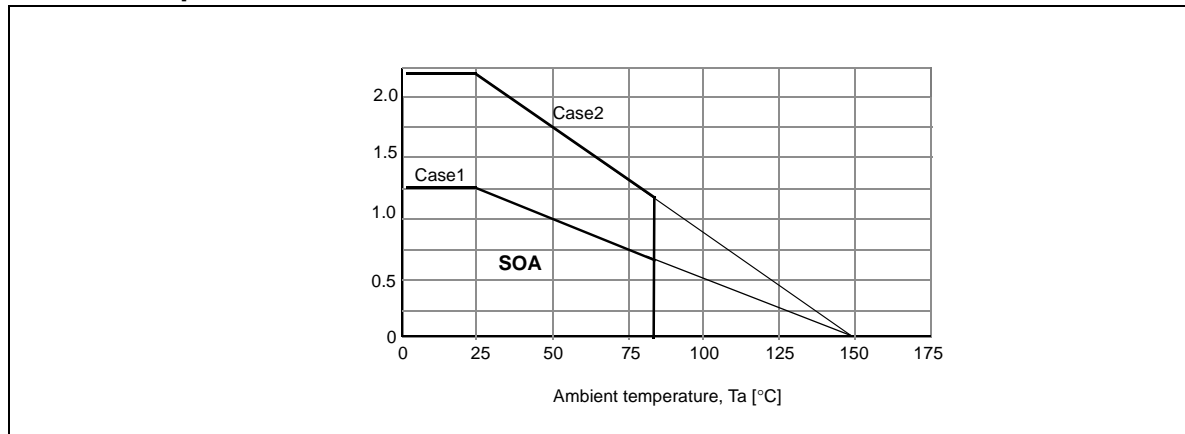

PCB condition : When mounted on 76.2mm × 114mm × 1.57mm PCB (glass epoxy material).

FAN8705 Electrical Characteristics

(Ta = 25°C, VDD = VM = 3V unless otherwise specified)

Parameter	Symbol	Conditions	Min.	Typ.	Max.	Unit
Total						
Standby current	ISTB	PS = L	-	-	1	μA
VDD Operating current	IOPR	PS = H	-	1	3	mA
Low voltage protection off	VUVLOF		-	-	2.39	V
Low voltage protection on	VUVLO		1.8	-	-	V
Input stage						
Logic input high voltage	V _{IH}		0.7XVDD	-	-	V
Logic input low voltage	V _{IL}		-	-	0.3XVDD	V
Logic input high current	I _{IH}	V _{input} = 3V	-	40	60	μA
Logic input low current	I _{IL}	V _{input} = 0V	-1	-	-	μA
Output Stage						
Ron resistance(CH1~CH4)	RON1	I _O =200mA (Upper+Lower)	-	1.1	1.5	Ω
Ron resistance(CH5)	RON2	I _O =200mA (Upper+Lower)	-	0.9	1.3	Ω
Constant voltage output		V _{in} =0.4V	1.85	1.95	2.05	V
Constant current accuracy			279	300	321	mA
Reference						
Reference voltage	VREF	IREF=2mA	0.93	0.98	1.03	V

Switching characteristics

(Ta = 25°C, VDD = VM = 3V unless otherwise specified)

CH1,2,3 Constant voltage H-bridge switching time ^{note1}						
Output turn on time	T _{ON}	Input rising time = 20ns Input 50% output 50%		1.5	3	μS
Output turn off time	T _{OFF}	Input rising time = 20ns Input 50% output 50%		0.03	0.1	μS
Output rising time	T _r	Input rising time = 20ns Output voltage 10% to 90%		1.5	3	μS
Output falling time	T _f	Input rising time = 20ns Output voltage 90% to 10%		0.03	0.1	μS
CH4 Saturated H-bridge switching time ^{note1}						
Output turn on time	T _{ON4}	Input rising time = 20ns Input 50% output 50%		0.2	0.5	μS
Output turn off time	T _{OFF4}	Input rising time = 20ns Input 50% output 50%		0.15	0.3	μS
Output rising time	T _{r4}	Input rising time = 20ns Output voltage 10% to 90%		0.1	0.3	μS
Output falling time	T _{f4}	Input rising time = 20ns Output voltage 90% to 10%		0.03	0.1	μS
CH5 Constant current switching time ^{note1}						
Output turn on time	T _{ON5}	Input rising time = 20ns Input 50% output 50%		0.5	1	μS
Output turn off time	T _{OFF5}	Input rising time = 20ns Input 50% output 50%		0.07	0.2	μS
Output rising time	T _{r5}	Input rising time = 20ns Output voltage 10% to 90%		0.1	0.3	μS
Output falling time	T _{f5}	Input rising time = 20ns Output voltage 90% to 10%		0.03	0.1	μS

note

1. Guaranteed by design. not tested

Rotation mode

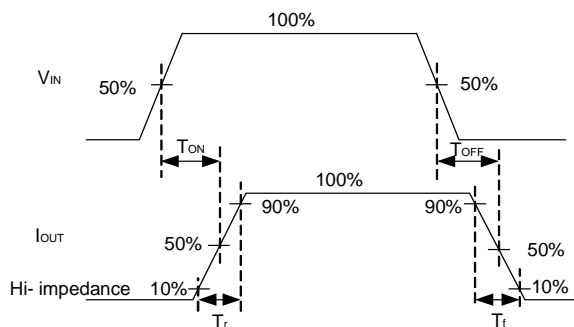

Brake mode

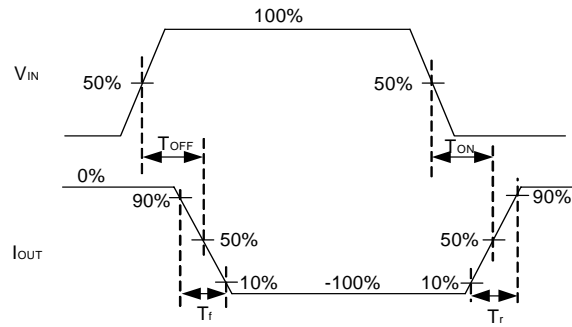

Operation Truth Table

	IN1	IN2	IN3	IN4	IN5	IN6	IN7	IN8	IN9	IN10	SEL	OUT 1	OUT 2	OUT 3	OUT 4	OUT 5	OUT 6	OUT 7	OUT 8	OUT 9	OUT 10	Remark							
	L	L	L	L	L	L	L	L	L	L	L	Z	Z	Z	Z	Z	Z	Z	Z	Z	Z	Z	Standby						
CH1	L	L										L	Z	Z											Z				
	L	H											Rotation																
	H	L											Rotation																
	H	H											Z	Z															
CH2			L	L										L			Z	Z							Z				
			L	H													Rotation												
			H	L													Rotation												
			H	H													Z	Z											
CH1 ~ CH2 2-2 phase	L	L										H	Z	Z											Z				
	L	H											Z	Z															
	H	L											H	L															
	H	H											L	H															
			L	L										H			Z	Z							Z				
			L	H													Z	Z											
			H	L													H	L											
			H	H													L	H											
CH3			L	L										L			Z	Z							Z				
			L	H													L	H											
			H	L													H	L											
			H	H													L	L											
CH4					L	L										*			Z	Z							Z		
					L	H													L	H									
					H	L													H	L									
					H	H													L	L									
CH5							L	L													Z	Z							Z
							L	H													L	H							
							H	L													H	L							
							H	H													Z	Z							

Gain control

Gain control	Input	H-bridge output control voltage	Remark
GAIN1	L	ADJ1	CH1,CH2
	H	0.67XADJ1	
GAIN2	L	ADJ2	CH 3
	H	0.33XADJ2	
GAIN3	L	ADJ3	CH 5
	H	0.33XADJ3	

Typical Performance Characteristics

Figure 1. VDD vs IOPR

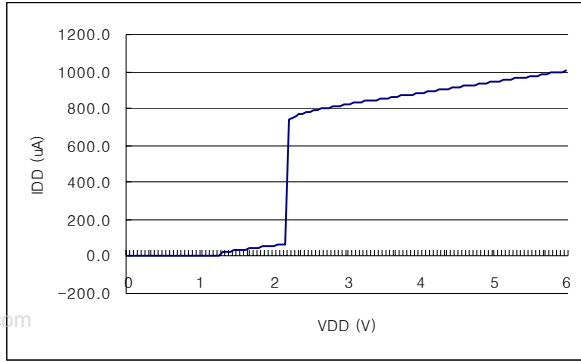

Figure 2. VDD vs ISTB

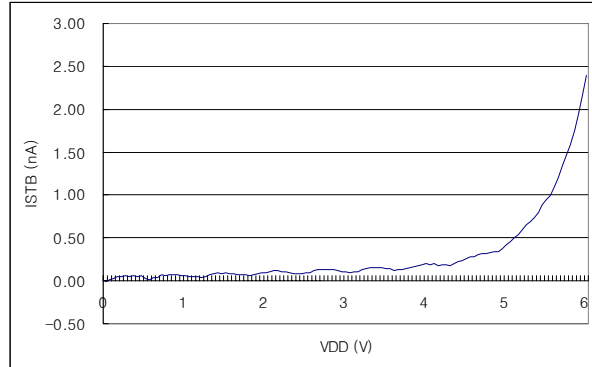

Figure 3. VDD vs IDD

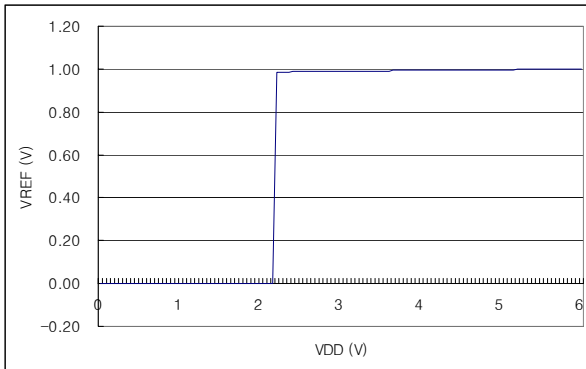

Figure 4. IREF vs VREF (VDD = 3V)

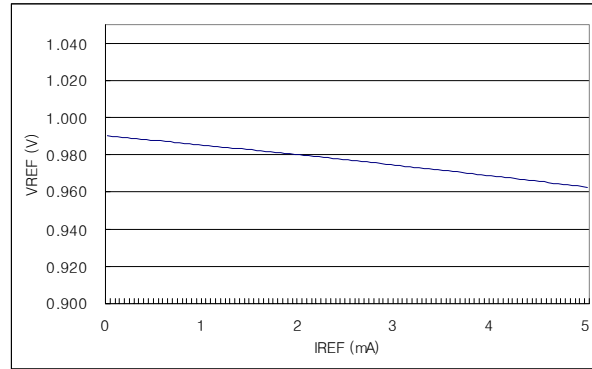

Figure 3. RON vs IM (VDD = 3V)

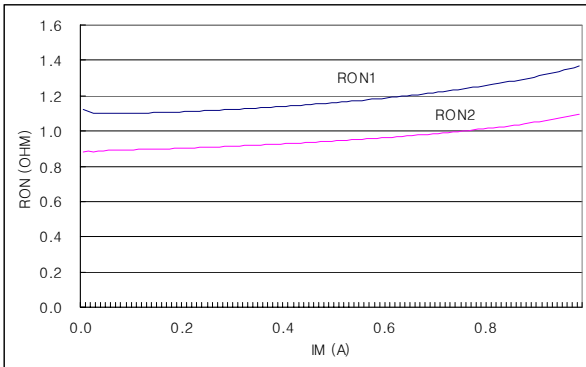
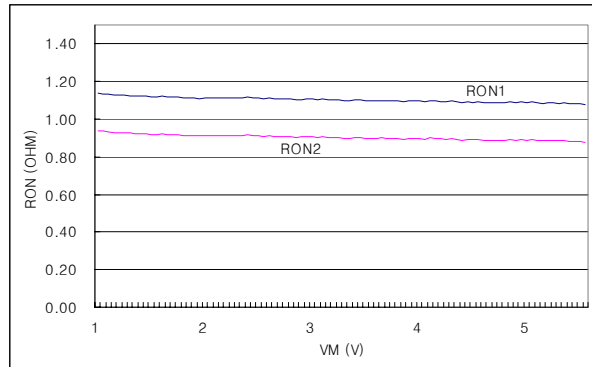

Figure 4. RON vs VM (VDD = 3V)



Application Information

1. Channel 1 and Channel 2

CH1 and CH2 are constant voltage driver. The output voltage can be calculated by following equations.

when, Gain1 = low,.

$$V_{MOTOR} = V_{ADJ1} \times 4.9 - V_{DSON} \approx V_{ADJ1} \times 4.9 = 3.6V$$

when, Gain1 = high

$$V_{MOTOR} = V_{ADJ1} \times \frac{2}{3} \times 4.9 - V_{DSON} \approx V_{ADJ1} \times \frac{2}{3} \times 4.9 = 2.4V$$

where, VMOTOR is motor driving voltage. VDSON is drain-source voltage of output lower MOSFET in on time, It's less than 0.1V@300mA. VADJ1 is about 0.75V typically as following equation. It can be adjusted by installing external resistor RADJ1. Calculated VMOTOR should be less than power supply voltage VM1 for operating constant voltage mode.

$$V_{ADJ1} = \frac{3}{4} \times V_{ref}$$

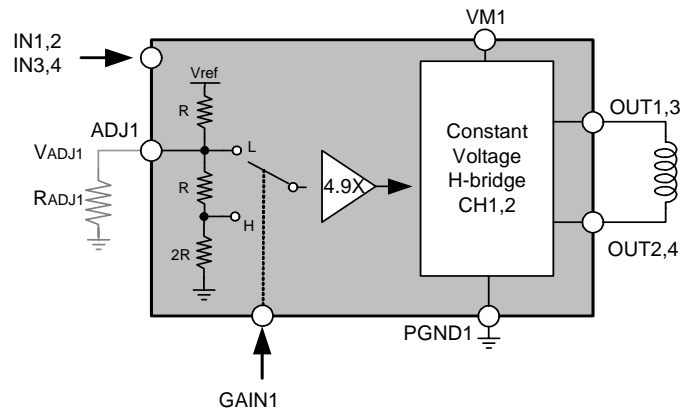

1.1 Stepping-Motor Drive

1.1.1 Three Input 2-2 Phase Excitation

SEL	IN1/IN3	IN2	IN4	OUT1	OUT2	OUT3	OUT4	Function
H	L	X	X	Z	Z	Z	Z	Stand-by(Stop)
	H	L	L	H	L	H	L	S1
	H	H	L	L	H	H	L	S2
	H	H	H	L	H	L	H	S3
	H	L	H	H	H	L	H	S4

note

- 1. X : Don't care.
- 2. Z : High impedance.

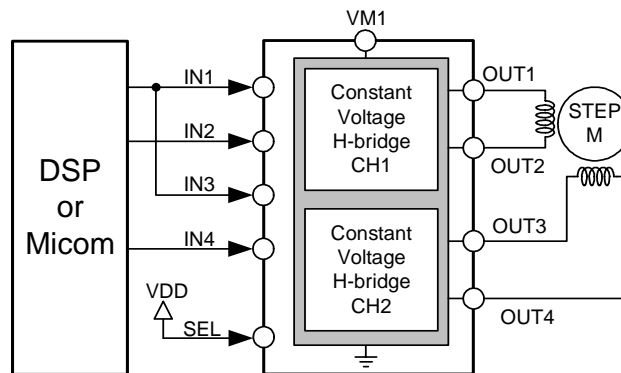
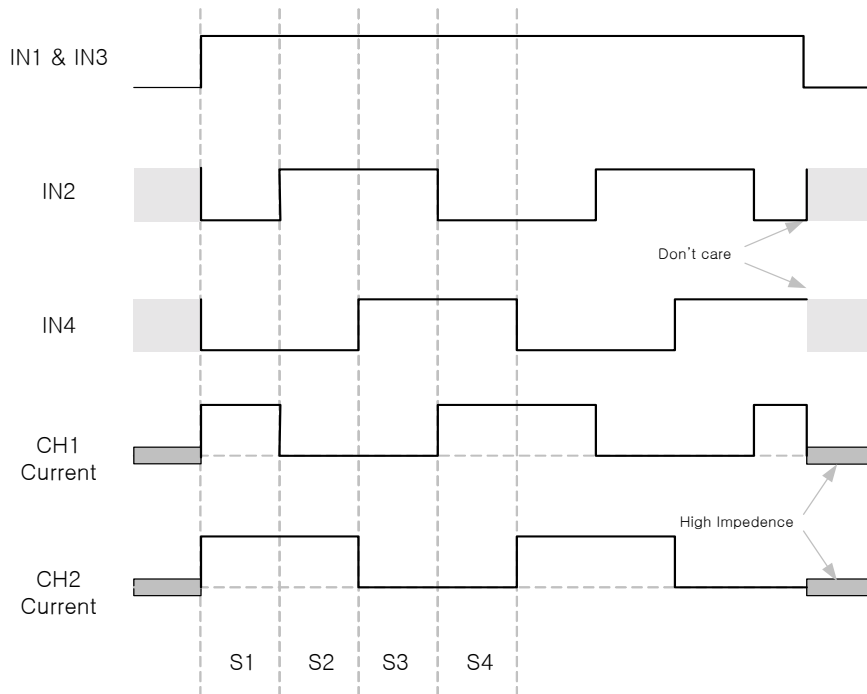

1.1.2 Four Input 1-2 Phase Excitation Mode1

SEL	IN1	IN2	IN3	IN4	OUT1	OUT2	OUT3	OUT4	Function
H	L	L	L	L	Z	Z	Z	Z	Stand-by(Stop)
	H	L	H	L	H	L	H	L	S1
	L	X	H	L	Z	Z	H	L	S2
	H	H	H	L	L	H	H	L	S3
	H	H	L	X	L	H	Z	Z	S4
	H	H	H	H	L	H	L	H	S5
	L	X	H	H	Z	Z	L	H	S6
	H	L	H	H	H	L	L	H	S7
H	L	L	X	H	L	Z	Z	S8	

note

- 1. X : Don't care.
- 2. Z : High impedance.

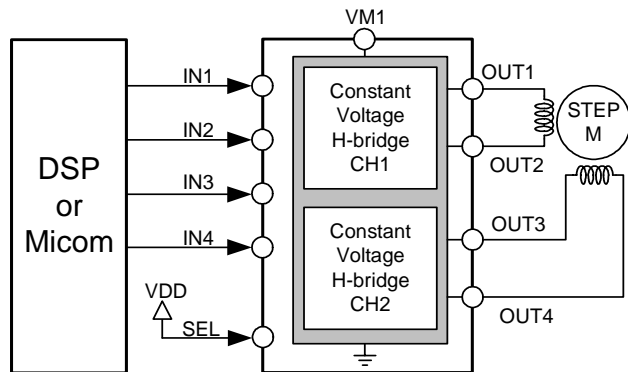
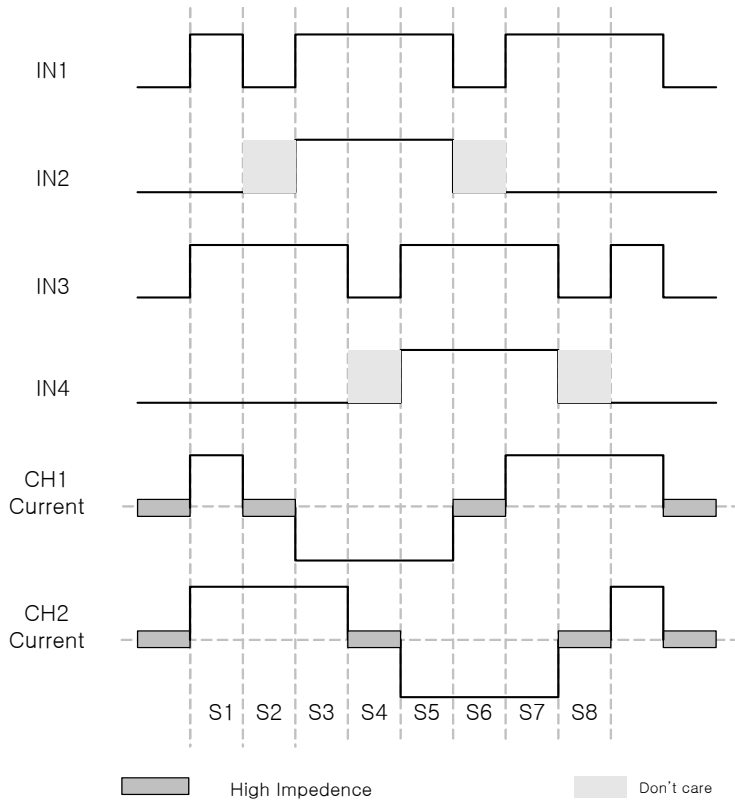

1.1.3 Four Input 1-2 Phase Excitation Mode2

SEL	IN1	IN2	IN3	IN4	OUT1	OUT2	OUT3	OUT4	Function
L	L	L	L	L	Z	Z	Z	Z	Stand-by(Stop)
	H	L	H	L	H	L	H	L	S1
	H	H	H	L	Z	Z	H	L	S2
	L	H	H	L	L	H	H	L	S3
	L	H	H	H	L	H	Z	Z	S4
	L	H	L	H	L	H	L	H	S5
	L	L	L	H	Z	Z	L	H	S6
	H	L	L	H	H	L	L	H	S7
H	L	L	L	H	L	Z	Z	S8	

note

1. Z : High impedance.

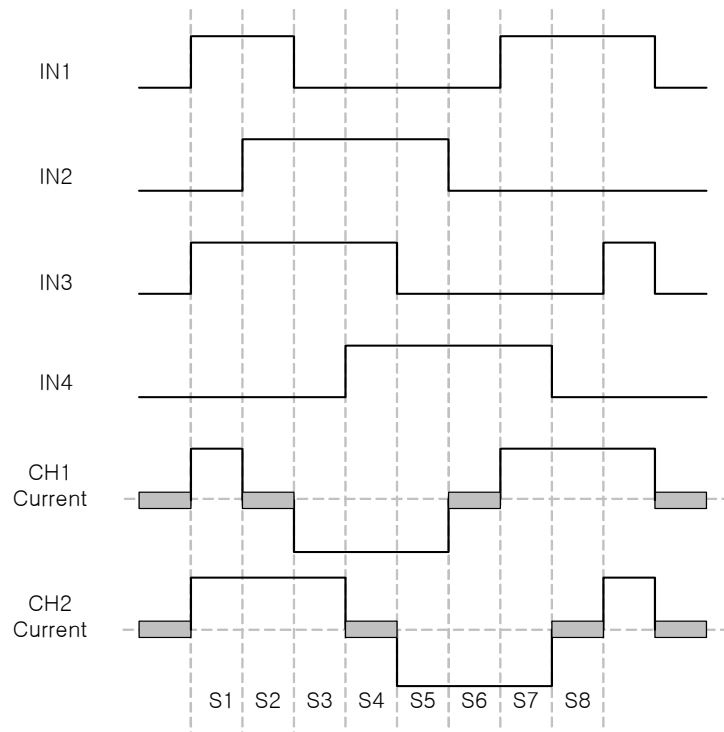

High Impedence

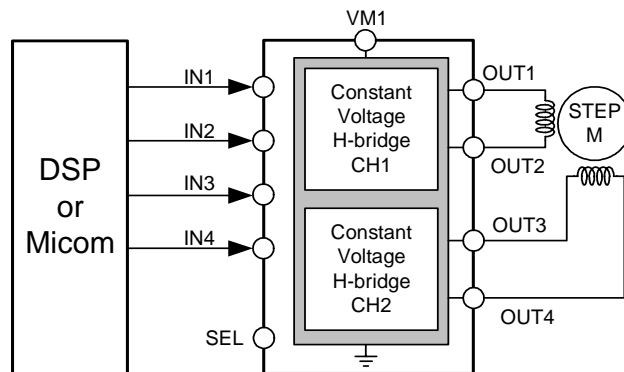

1.1.4 Pseudo Sine Wave Excitation

SEL	IN1	IN2	IN3	IN4	GAIN1	OUT1	OUT2	OUT3	OUT4	Function
L	L	L	L	L	X	Z	Z	Z	Z	Stand-by(Stop)
	H	L	H	L	H	H	L	H	L	S1
	H	H	H	L	L	Z	Z	H	L	S2
	L	H	H	L	H	L	H	H	L	S3
	L	H	H	H	L	L	H	Z	Z	S4
	L	H	L	H	H	L	H	L	H	S5
	L	L	L	H	L	Z	Z	L	H	S6
	H	L	L	H	H	H	H	L	L	H
H	L	L	L	L	H	L	Z	Z	S8	

note

1. X : Don't care.
2. Z : High impedance.

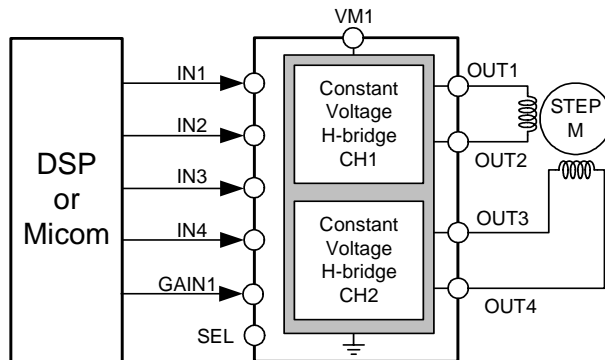
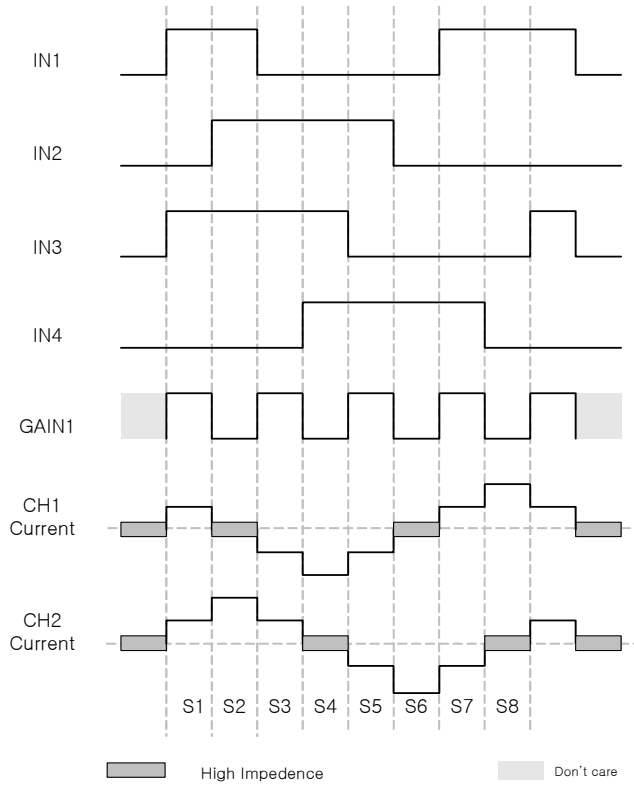

2. Channel 3

CH3 is constant voltage driver. The output voltage can be calculated by following equations.

When, Gain2 = low,.

$$V_{MOTOR} = V_{ADJ2} \times 4.9 - V_{DSON} \approx V_{ADJ2} \times 4.9 = 3.6V$$

when, Gain2 = high

$$V_{MOTOR} = V_{ADJ2} \times \frac{1}{3} \times 4.9 - V_{DSON} \approx V_{ADJ2} \times \frac{1}{3} \times 4.9 = 1.2V$$

where, VMOTOR is motor driving voltage. VDSON is drain-source voltage of output lower MOSFET in on time, It's less than 0.1V@300mA. VADJ2 is about 0.75V typically as following equation. can be adjusted by installing external resistor RADJ2. Calculated VMOTOR should be less than power supply voltage VM2 for operating constant voltage mode.

www.DataSheet4U.com

$$V_{ADJ2} = \frac{3}{4} \times V_{ref}$$

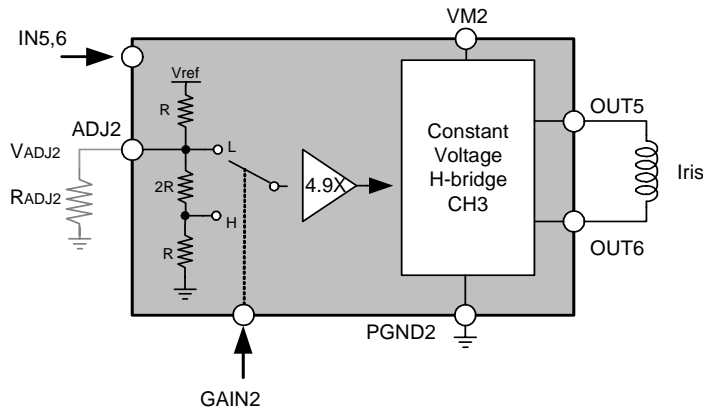

3. Channel 4

Channel 4 is operated by saturated H-bridge mode.

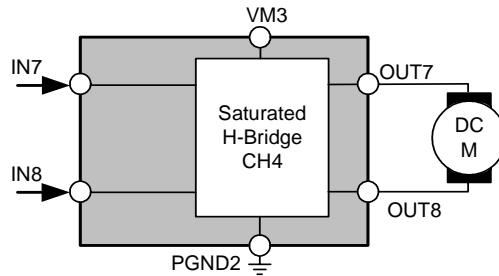

4. Channel 5

Channel 5 is constant current driver. motor current is determined by ADJ3 voltage V_{ADJ3} , sensing resistance R_{SENSE} and GAIN3 input and calculated by the following equation.

when, GAIN3 = Low

$$I_{MOTOR} = \frac{V_{ADJ3}}{R_{Sense} + R_W}$$

when, GAIN3 = High

$$I_{MOTOR} = \frac{V_{ADJ3} \times 1/3}{R_{Sense} + R_W}$$

where, R_W is internal bonding resistance and metal resistance is around 0.05Ω

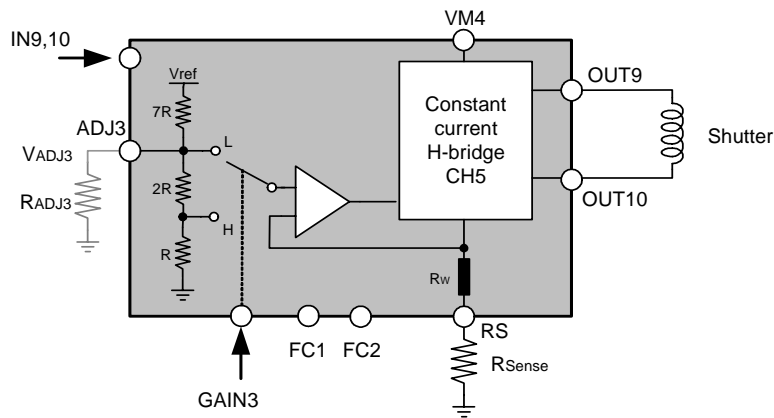

If oscillation or overshoot will be appeared in the output terminals, add external capacitors at FC1 and FC2 terminals. The output response time depend on the FC1/FC2 capacitance and interval of input signal.

6. Saturated H-Bridge Drive

Saturated H-bridge drive mode can be implemented using the constant current drive block or the constant voltage drive blocks.

6.1 Saturated H-Bridge Drive Using Constant Current Drive Block

Saturated H-bridge drive mode using the constant current drive block can be operated with ADJ3 connected to VREF input and current sensing terminal RS connected to ground.

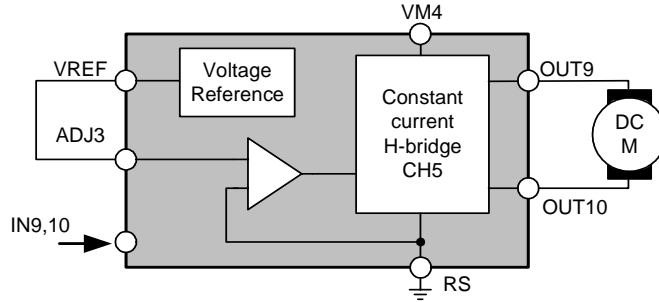

6.2 Saturated H-Bridge Drive Using Constant Voltage Drive Block

GAIN1/GAIN2 pin is open or connected to ground and ADJ1/ADJ2 input should be connected to VREF when VM1/ VM2 is less than 5V. If VM1/VM2 is more than 5V, ADJ1/ADJ2 input should be connected to power supply input.

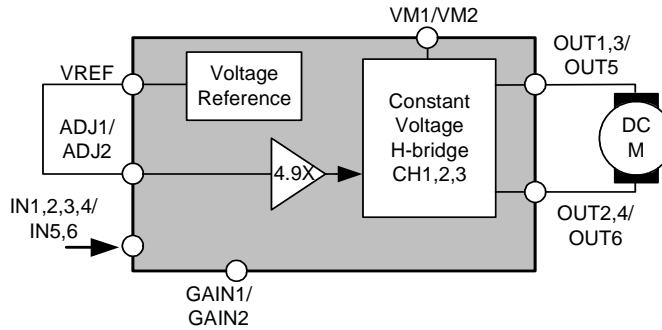

5. Power Saving

The typical timing chart to get 1 frame of still image or motion pictures for shutter operation is shown following fig. If shutter is fully opened within some time interval(t_{o1}) depending on shutter motor and mechanism, then we don't need to operate shutter motor to be opened more in 'WEAK OPEN'(t_{o2}). In other words we simply maintain the shutter open. The method to maintain this is to reduce shutter current by control GAIN3 input. So, battery power can be saved. and 'WEAK CLOSE' is the same.

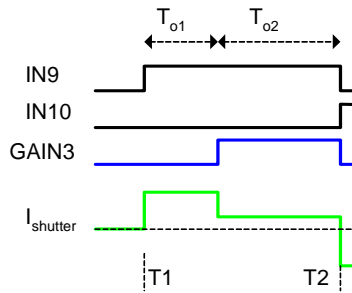
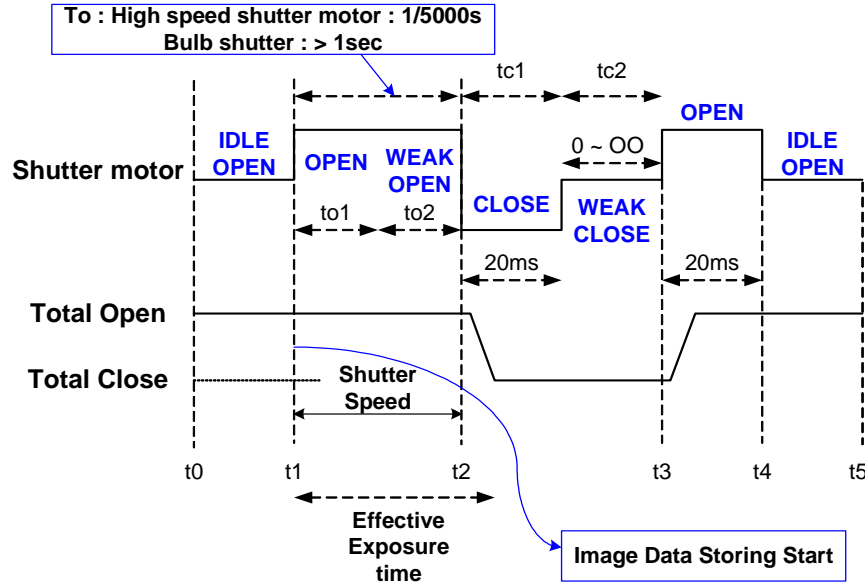

7. Short Circuit Protection

A short circuit can occur for many reasons , a short on the load, a mistake during the connection of the wires between the device and the load, an accidental short between the wires and so on. The outputs are not protected against the short circuit and if a short occurs, the big amount of current flowing through the outputs can destroy the device. To avoid this risk can be useful to add a circuitry to protect the device. FAN8705 have two types of short circuit protection, output to output short and output to ground short.

8. Thermal Shutdown

Thermal Shutdown Circuit turns OFF all outputs when the junction temperature typically reaches 175°C. It is intended to protect the device from failures due to excessive junction temperature.

The Thermal Shutdown has the hysteresis of 25°C approximately.

Typical Application Circuits 1

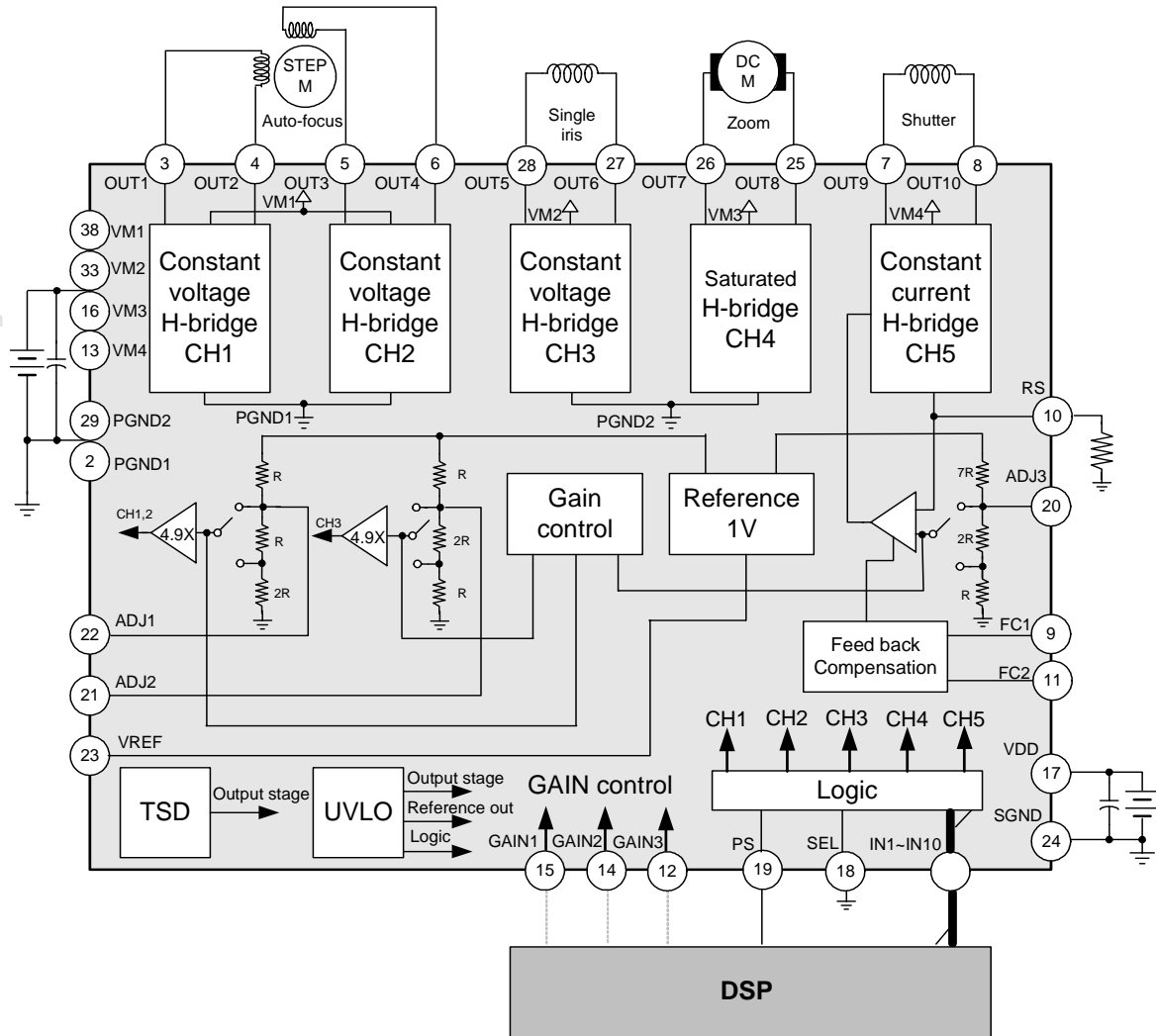

Package Dimensions (Unit: mm)

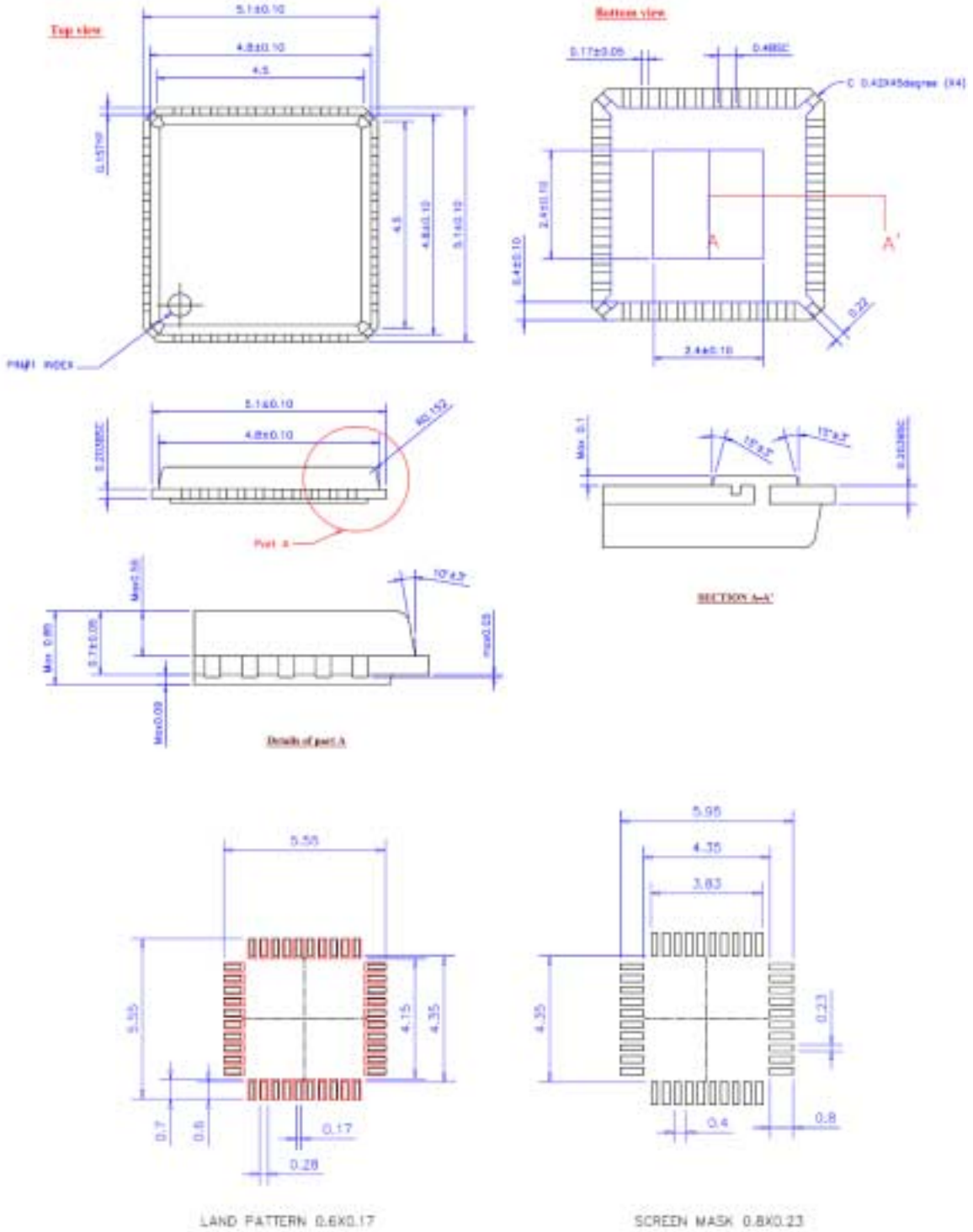

Recommended Design

TRADEMARKS

The following are registered and unregistered trademarks Fairchild Semiconductor owns or is authorized to use and is not intended to be an exhaustive list of all such trademarks.

ACEx™	FACT Quiet Series™	ISOPLANAR™	POP™	SuperFET™
ActiveArray™	FAST®	LittleFET™	Power247™	SuperSOT™-3
Bottomless™	FASTr™	MICROCOUPLER™	PowerTrench®	SuperSOT™-6
CoolFET™	FPS™	MicroFET™	QFET®	SuperSOT™-8
CROSSVOLT™	FRFET™	MicroPak™	QS™	SyncFET™
DOMET™	GlobalOptoisolator™	MICROWIRE™	QT Optoelectronics™	TinyLogic®
EcoSPARK™	GTO™	MSX™	Quiet Series™	TINYOPTO™
E ² CMOS™	HiSeC™	MSXPro™	RapidConfigure™	TruTranslation™
EnSigna™	I ² C™	OCX™	RapidConnect™	UHC™
FACT™	ImpliedDisconnect™	OCXPro™	SILENT SWITCHER®	UltraFET®
Across the board. Around the world.™	OPTOLOGIC®	SMART START™	SPM™	VCX™
The Power Franchise™	OPTOPLANAR™	Stealth™		
Programmable Active Droop™	PACMAN™			

DISCLAIMER

FAIRCHILD SEMICONDUCTOR RESERVES THE RIGHT TO MAKE CHANGES WITHOUT FURTHER NOTICE TO ANY PRODUCTS HEREIN TO IMPROVE RELIABILITY, FUNCTION OR DESIGN. FAIRCHILD DOES NOT ASSUME ANY LIABILITY ARISING OUT OF THE APPLICATION OR USE OF ANY PRODUCT OR CIRCUIT DESCRIBED HEREIN; NEITHER DOES IT CONVEY ANY LICENSE UNDER ITS PATENT RIGHTS, NOR THE RIGHTS OF OTHERS.

LIFE SUPPORT POLICY

FAIRCHILD'S PRODUCTS ARE NOT AUTHORIZED FOR USE AS CRITICAL COMPONENTS IN LIFE SUPPORT DEVICES OR SYSTEMS WITHOUT THE EXPRESS WRITTEN APPROVAL OF FAIRCHILD SEMICONDUCTOR CORPORATION. As used herein:

1. Life support devices or systems are devices or systems which, (a) are intended for surgical implant into the body, or (b) support or sustain life, or (c) whose failure to perform when properly used in accordance with instructions for use provided in the labeling, can be reasonably expected to result in significant injury to the user.

2. A critical component is any component of a life support device or system whose failure to perform can be reasonably expected to cause the failure of the life support device or system, or to affect its safety or effectiveness.

PRODUCT STATUS DEFINITIONS

Definition of Terms

Datasheet Identification	Product Status	Definition
Advance Information	Formative or In Design	This datasheet contains the design specifications for product development. Specifications may change in any manner without notice.
Preliminary	First Production	This datasheet contains preliminary data, and supplementary data will be published at a later date. Fairchild Semiconductor reserves the right to make changes at any time without notice in order to improve design.
No Identification Needed	Full Production	This datasheet contains final specifications. Fairchild Semiconductor reserves the right to make changes at any time without notice in order to improve design.
Obsolete	Not In Production	This datasheet contains specifications on a product that has been discontinued by Fairchild semiconductor. The datasheet is printed for reference information only.

Rev. 17