

FBA09A (92mm)

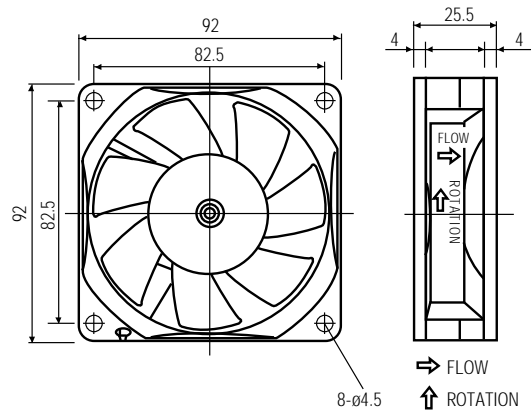

Housing with solid corner type is also available

CUT OUT

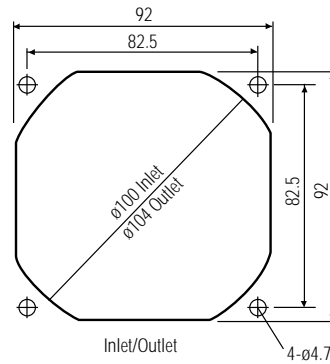

Features

- Operating Temperature: -10°C — +70°C (65% RH)
- Storage Temperature: -40°C — +75°C (65% RH)
- Bearing Type: Hydro Wave
- Connector Type: Plug-In
- Aerodynamic blade and venturi design

- Locked rotor protection and auto-start function
- Lower circuit noise by new IC
- Optional third lead wire signal (Locked rotor alarm sensor, 2PPR)
- Easy value add access to lead wires via plug-in connector on housing

Basic Data (nominal at room temperature)

	Rated Voltage (V)	Operating Voltage (V)	Rated Current (mA)	Rated Input (W)	Nominal Speed (r/min)	Maximum Air Flow		Maximum Air Pressure		Noise (dB-A)
						(m3/min)	(CFM)	(mmH2O)	(Pa)	
FBA09A12L	12	7—13.8	110	1.32	2100	1.21	42.7	2.30	22.6	27.0
FBA09A12M	12	7—13.8	150	1.80	2450	1.36	48.0	3.00	29.4	30.0
FBA09A12H	12	7—13.8	225	2.70	2850	1.61	56.8	3.98	39.0	35.0
FBA09A12U	12	7—13.8	430	5.16	3450	1.95	68.8	5.0	49.0	43.0
FBA09A24L	24	14—27.6	80	1.92	2100	1.21	42.7	2.30	22.6	27.0
FBA09A24M	24	14—27.6	110	2.64	2450	1.36	48.0	3.00	29.4	30.0
FBA09A24H	24	14—27.6	140	3.36	2850	1.61	56.8	3.98	39.0	35.0

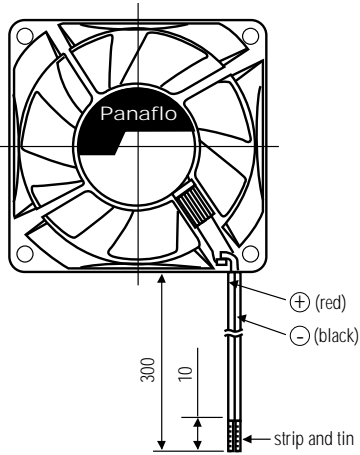

All dimensions in mm.

Lead Wire

All lead wires are 295 mm. in length \pm 15 mm. (bare wire 10mm \pm 5mm.)

Housing and Fan Blade: Plastic (PET, PBT, ABS)

Size

92.0 x 92.0 x 25.5
(3.62 x 3.72 x 1.00)

Weight

110 grams (3.88 ounces)

Case Quantity

100 per box

Conversion Factors

1 mm H₂O = 9.8 PA

1 m³/min = 35.313 CFM

— P—Q
— N—Q

FBA09A (92mm)
Characteristics

