

## Fibre Channel Transceiver 1.0625 GBaud

PRELIMINARY DATA

### FEATURES

- Serial Link Transceiver
  - serializer and deserializer
  - implementing the Fibre Channel FC0 and FC1 layers
- Direct support for 1.0625 GBaud Fibre Channel (ANSI X3.230-1994) rates
- Fibre Channel 10-bit Interface (ANSI TR/X3.18-199X)
- Direct interfaces to optical transceivers
- Plesiochronous mode operation
  - transmitter and receiver clock frequencies may differ by up to 100 ppm
- Integrated Fibre Channel 8b/10b encode/decode (optional use through JTAG)
- Byte and word synchronization of incoming serial stream
- Supports any DC-balanced encoding scheme
- Internal Loop-Back for Self-Test
- Random Pattern Auto-Test
- Optional integrated impedance adaptation to transmission line characteristics (50 or 75 ohms)
- TTL compatible parallel I/O's
- JTAG Test Access Port
- 0.35 $\mu$  CMOS Technology for low cost and low power
- PQFP package available in two sizes: 14x14 mm (FC106/14) or 10x10 mm (FC106/10)

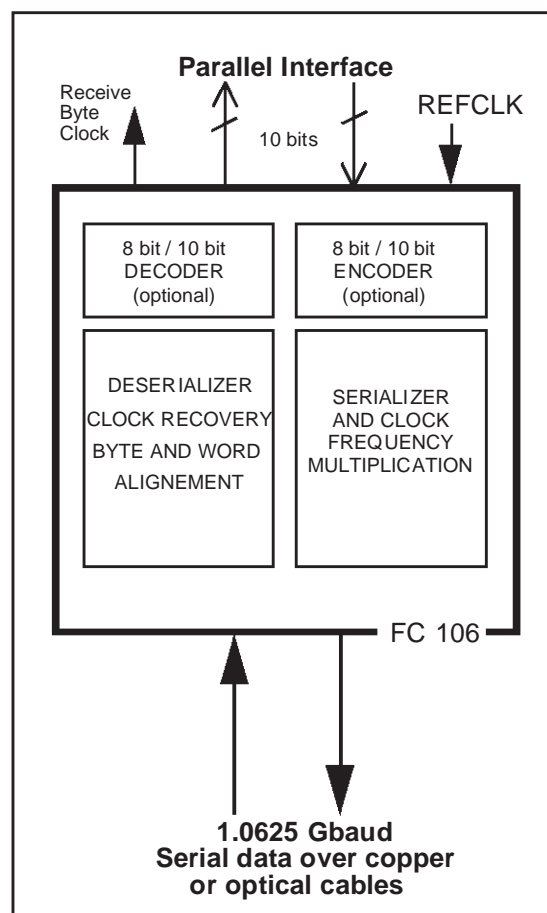

### APPLICATIONS

- Fibre Channel Arbitrated Loop
- Fibre Channel fabric
- Transmission schemes encoding bytes as 10-bit characters to form a DC-balanced stream
- High performance backplane interconnect

---

# Table of Contents

<b>1</b>	<b>General Description</b>	<b>4</b>
<b>2</b>	<b>Interface Diagram</b>	<b>6</b>
<b>3</b>	<b>Functional Description</b>	<b>7</b>
	3.1 Block diagram	8
	3.2 Input latches	8
	3.3 8bit/10bit Encoder/Decoder	9
	3.4 DLL clock generator	9
	3.5 Serializer functional description and reference clock	9
	3.6 Serializer latches and XOR-tree	10
	3.7 Serial input multiplexer	10
	3.8 Deserializer functional description	10
	3.9 Bit alignment	11
	3.10 Byte and word alignment	12
	3.11 Clock recovery	12
	3.12 Serial input-output buffer	13
	3.13 I/O impedance control	14
	3.14 Self-test	15
<b>4</b>	<b>Serial I/O Electrical Model</b>	<b>16</b>
<b>5</b>	<b>Electrical Specifications</b>	<b>17</b>
	5.1 Absolute maximum ratings	17
	5.2 Operating conditions	17
	5.3 DC characteristics	18

<b>6</b>	<b>Timing Specifications</b>	<b>20</b>
	6.1 Transmit interface timing and latency	20
	6.2 Receive interface timing	21
	6.2.1 Receive clock timing and latency	21
	6.2.2 Receive interface timing	23
	6.3 Serial Input/output AC characteristics	24
<b>7</b>	<b>FC106 Pin Description</b>	<b>25</b>
	7.1 Pin summary	25
	7.2 Pin functions	26
<b>8</b>	<b>Package Specifications</b>	<b>29</b>
	8.1 FC106 64-pin PQFP pinout	29
	8.2 FC106 64-pin Quad Flat-pack package dimensions	30
	8.2.1 FC106/14: 14x14 mm package dimensions	30
	8.2.2 FC106/10: 10x10 mm package dimensions	31

# 1 General Description

The FC106 Fibre Channel transceiver chip implements the lower layer protocols of the ANSI X3.230-1994 Fibre Channel standard. The Fibre Channel standard specifies the mapping of various upper layer protocols (ULP) such as SCSI, IP and HiPPI to a common lower layer protocol, together with appropriate electrical and optical high performance specifications. Fibre Channel provides a channel over which concurrent communication of a variety of ULP's may exist on a single interconnect between workstations, mainframes and supercomputers, and provides a connection to mass storage devices and other peripherals.

The FC106 implements the Fibre Channel electrical transceiver physical layer specification for 1.0625 Gbit/s. At this frequency, the Fibre Channel delivers 100 MByte/s of data bandwidth over a twin coaxial or twin optical fibre cable. This bandwidth equals or exceeds most bus bandwidths. The FC106 chip performs the high speed serialization and deserialization function that makes bus-bandwidth, serial communication possible. This chip can drive electrical cables directly or it can interface with suitable optical modules. Figure 1.1 shows the different connections.

**Figure 1.1 FC106 chip connections**

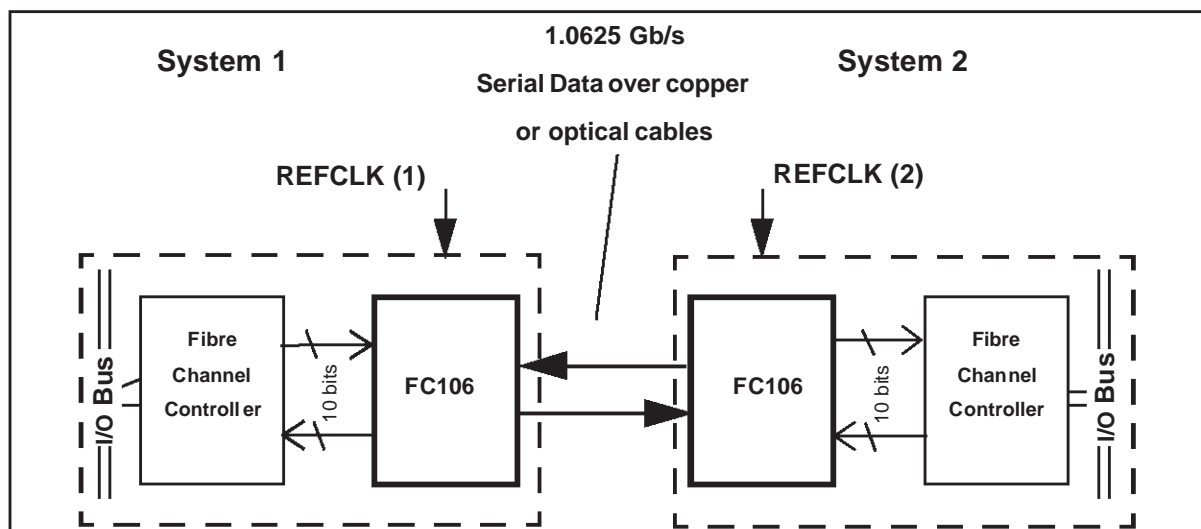

The parallel interface on the FC106 is compatible with the 10-Bit Interface Specification (ANSI TR/X3.18-1998) which defines a common, standard signaling interface between the Fibre Channel Physical and Protocol layers. In addition, the FC106 can be used for all other proprietary serial links transmitting data as 10-bit encoded characters.

The FC106 incorporates an impedance adaptor circuit (set by the pins ZC+, ZC-) to ensure high quality adaptation to the transmission line characteristic impedance. This feature is optional and the user can keep external adaptation for compatibility reasons.

## FC106

---

The FC106 integrates a loop-back path for system-level test purposes. It also includes a self-test capability in which random patterns are transmitted through the internal loop-back path and compared after reception.

The FC106 is implemented in a standard digital 0.35 $\mu$  CMOS process. Its typical power consumption is 0.4 Watts (not including the power required to drive the TTL parallel output port, which is in the 0.1 Watt range for output capacitive loads of 10 pF per pin).

## 2 Interface Diagram

Figure 2.1 Interface diagram

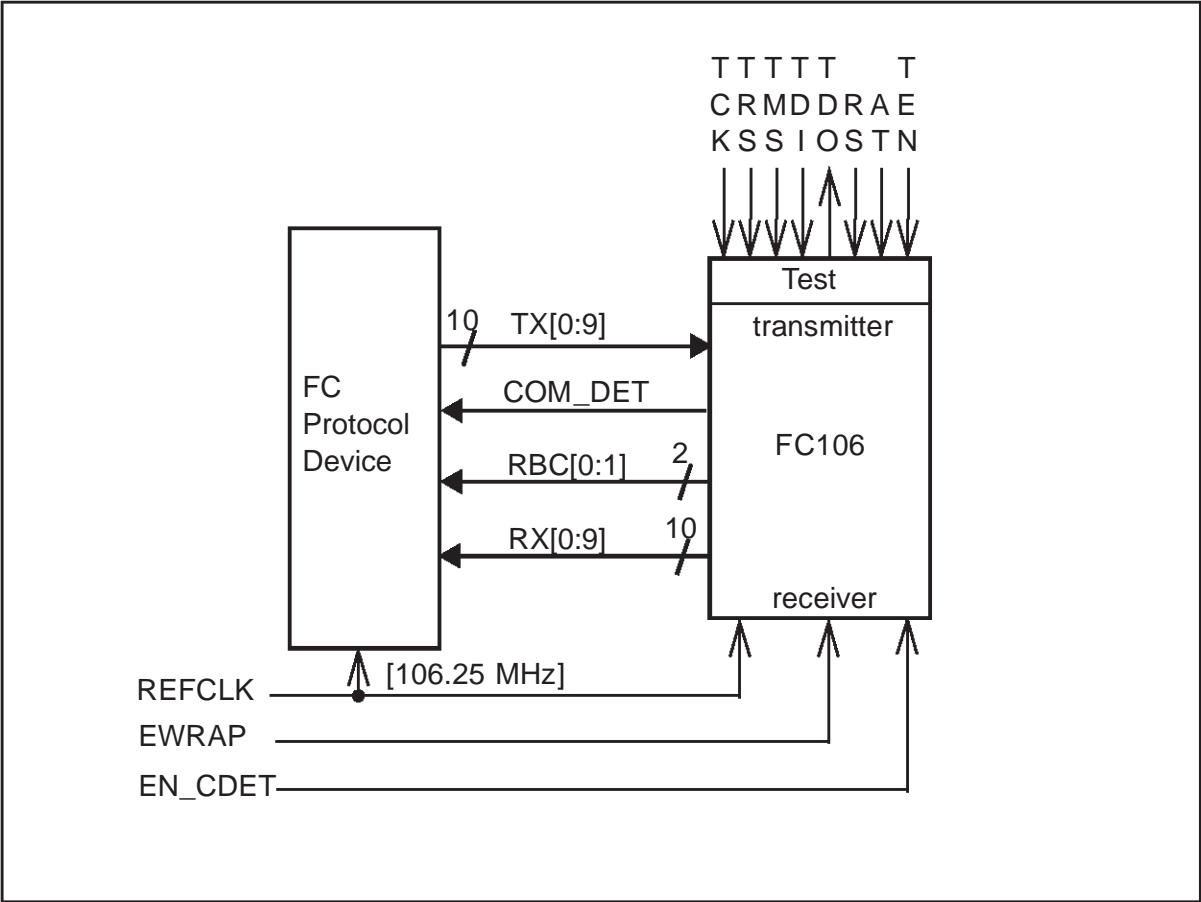

### 3 Functional Description

The FC106 provides all required signals in the 10-Bit Interface Specification for Fibre Channel. It also provides 10 pins for additional functions (these pins are marked in the following by \*). The additional functions are:

- impedance control (ZC+\*, ZC-\*)
- production test through JTAG (TCK(\*)-TRSTN(\*)-TMS(\*)-TDI(\*)-TDO(\*)- TEST ENABLE(\*)
- self-test of the chip (AT\*)
- reset pin (RS) (but note that another reset is automatically generated in the chip during power on).

In addition to implementing the Fibre Channel standard, the FC106 is adaptable through the JTAG path to the transmission of any sequence of 10-bit encoded characters at rates varying between 1 and 1.1 Gbaud.

### 3.1 Block diagram

Figure 3.1 Block diagram

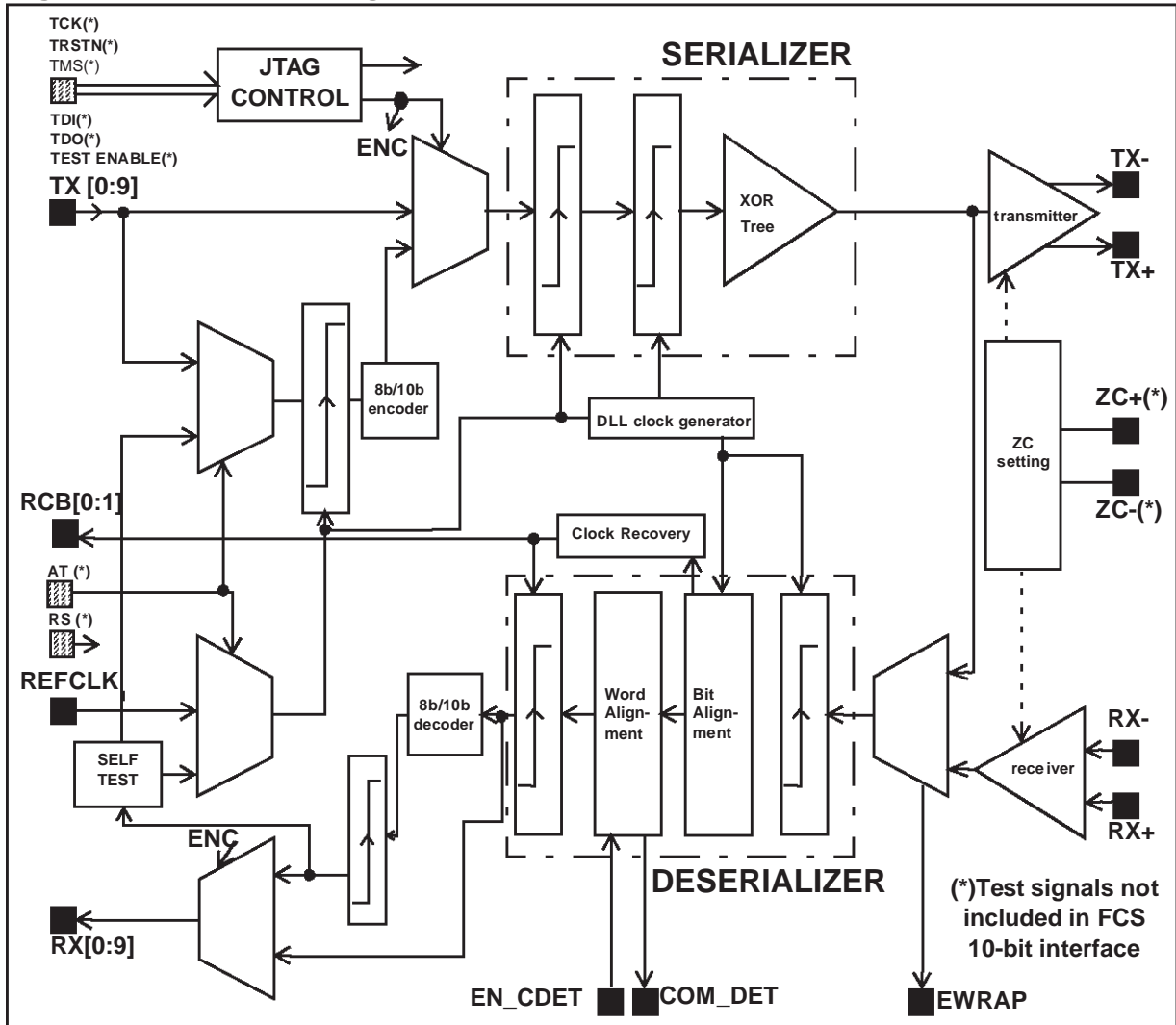

### 3.2 Input latches

The transmitter accepts 10-bit wide TTL parallel data at inputs TX[0:9]. The user-provided reference clock signal REFCLK is also used as the transmit byte clock. The TX[0:9] and REFCLK signals must be properly aligned, as shown in Section 6.1: *Transmit interface timing and latency* on page 20.



### **3.3 8bit/10bit Encoder/Decoder**

In normal operation mode, the FC106 accepts 10-bit pre-encoded data, and provides to the application, 10-bit encoded data (as specified in the ANSI 10-bit Interface Specification).

In addition, the FC106 contains an 8b/10b encoder/decoder, which can be inserted into the data flow. The selection of this mode is made through the JTAG path. In this mode, the FC106 accepts and delivers bytes on 9 bits (8 bits of data on TX/RX[0:7] and 1 bit on TX/RX[8] which is used to differentiate control characters). The timings of the parallel I/O ports are identical in both modes: using the 8b/10b encoder/decoder increases the transmission latency by 2 byte clock periods (equivalent to a 4 meter increase of the cable length).

### **3.4 DLL clock generator**

The Delay Locked Loop (DLL) block generates the internal clocks. These are required by the transmitter section to perform its function, and by the receiver block to generate the reference clocks which are used to recover the serial data input frequency. These clocks are based on the user supplied reference byte clock REFCLK. This clock is multiplied by 10 to generate the required serial output data rate. No external components are required to operate the DLL Clock Generator.

### **3.5 Serializer functional description and reference clock**

The FC106 serializer performs the serialization of 10-bit pre-encoded parallel data at signaling rates up to 1.0625 Gb/s. System design is simplified by the integration into the chip of a block performing clock multiplication from the parallel data clock.

It accepts 10-bit encoded parallel data words which are clocked into the device at 1/10 of the signaling rate. For Fibre Channel use, data should be encoded for transmission using the 8B/10B block code described in the Fibre Channel specification. The FC106 serializes the input data and transmits it at a signaling rate of 10 times the frequency of the REFCLK input. The device includes a Delay-Locked-Loop based clock multiplier that generates the 1.0625 Gbaud clocks. This DLL is fully monolithic and requires no external components. Its acquisition time, at power-up, is less than 16 microseconds.

The FC106 loads parallel data on the rising edge of REFCLK. The delay through the FC106 from loading the code-group to the transmission of the first bit of the code-group on the TX+, TX- pair, is 17.4 ns with an extra 9.4 ns if the 8b10b encoding function is enabled.

A loop-back-mode signal EWRAP is provided allowing internal dynamic self-test of the chip. When EWRAP is low, the output of the transmitter is sent to the TX+ and TX- output pins, and the input of the receiver is driven by the signals entered through the RX+ and RX- pins.

When EWRAP is high, the output of the transmitter is sent directly to the input of the receiver.

### **3.6 Serializer latches and XOR-tree**

The parallel data words TX[0:9] are individually sampled using the clocks provided by the DLL Clock Generator. The outputs of these serializer latches are merged through an Exclusive-OR tree, in order to generate the output data bit streams.

### **3.7 Serial input multiplexer**

The Input Multiplexer supports the internal loopback of the high speed serial signal for test purposes.

In normal operation, EWRAP is set low. The serial output data stream is placed at TX+/TX- outputs, and the serial data accepted at RX+/RX- is transmitted to the deserializer block.

When wrap-mode is activated by setting EWRAP high, the serial data generated by the serializer block is internally wrapped to the input of the deserializer block.

### **3.8 Deserializer functional description**

The FC106 deserializer operates at signaling rates up to 1.0625 Gb/s, as specified in the Fibre Channel standard. It extracts the clock and retimes the data from the serial bit stream. The serial bit stream should be encoded as 10-bit characters (for example the 8B/10B code for Fibre Channel) which provide a transition density greater than 10%. The retimed serial bit stream is converted into a 10-bit parallel output word. The FC106 has internal DLL based clock recovery circuit which requires no external components.

When the DLL of the serializer clock multiplier is locked to the expected data rate (defined by REFCLK), the retiming acquisition time (to lock to the incoming serial data stream) is less than 3 microseconds.

The FC106 provides byte and data word alignment using a comma symbol recognition mechanism.

The 7-bit comma symbol is defined in Fibre Channel specification as a [0:6]= 0011111. This pattern is only contained within special characters known as K28.1, K28.5 and K28.7 defined specifically for synchronization by Fibre Channel.

Serial data is received on the RX+ and RX- pins. The DLL clock recovery circuit will lock to the data stream if the clock to be recovered is within 0.01% of the expected data rate. For

## FC106

---

example, if the REFCLK used is 106.25 MHz, then the incoming data serial signaling rate must be  $1.0625 \pm 0.0001$  Gb/s.

The FC106 provides 2 TTL recovered clocks RBC[0] and RBC[1], which are both driven at a frequency of one twentieth of the serial signaling rate. These clocks are generated by the clock recovery DLL, which is phase locked to the serial data. RBC[1] is 180° out of phase with RBC[0]. If serial data is not present, or does not meet the required transition density or signaling rate, the RBC frequencies will be half of the expected recovered clock frequency (defined by REFCLK). This function replaces the optional LCK\_REF signal that is specified in the Fibre Channel 10-bit interface. When no data is present, phase adjustments are required for switching between a locking to incoming data and locking to REFCLK. The specification on output clocks RBC[0:1] is maintained during these adjustments. The clock periods are not truncated.

The serial data is retimed and deserialized. Parallel data is loaded into the output register, and therefore accessible on the output data port. For Fibre Channel use, bytes 1 and 3 of the receive data word will be accessible on the rising edge of RBC[0], and bytes 0 and 2 on the rising edge of RBC[1].

Word synchronization is enabled in the FC106 by connecting the EN\_CDET pin to  $V_{dd}$ . When EN\_CDET is set high, the FC106 examines serial data for the presence of a positive disparity comma symbol (0011111). Improper alignment occurs when a comma symbol straddles a 10-bit boundary or is not aligned within the 10-bit transmission character. Proper alignment is reached by shifting the boundary of the parallel output.

At power up the FC106 will not be in synchronization and data alignment is not established. The COM\_DET output signal is then set low. When a comma symbol is detected, COM\_DET is set high (if EN\_CDET is already set high). COM\_DET will go high only during a cycle in which RBC[1] is rising (see Section 6.2.2: *Receive interface timing* on page 23 for precise timing).

Note that if EN\_CDET is set low, but a comma is detected while the input stream is already word-aligned, COM\_DET will be set high again.

### 3.9 Bit alignment

The alignment block aligns the incoming data bit stream and the reference clocks generated by the DLL Clock Generator. It compensates for clock frequency dispersions between the crystals generating the respective reference clocks REFCLK of the transmitting and receiving chips.

### 3.10 Byte and word alignment

The word alignment function is performed under control of the EN\_CDET signal.

When EN\_CDET is high, the word alignment function is operational. If an improperly aligned comma is encountered, the internal data is shifted to realign the comma character at the deserializer output (RX[0:9]). In this process, up to three characters prior to the comma character may be corrupted.

### 3.11 Clock recovery

The clock recovery block generates the two receiver byte clocks RBC[0:1] at half the frequency corresponding to the RX+/RX- byte data rate. These two byte clocks are 180° out of phase with each other. They are alternatively used to clock the 10-bit parallel output data.

### 3.12 Serial input-output buffer

Figure 3.2 shows a simplified schematic of the serial I/O.

Figure 3.2 Schematic diagram of serial I/O

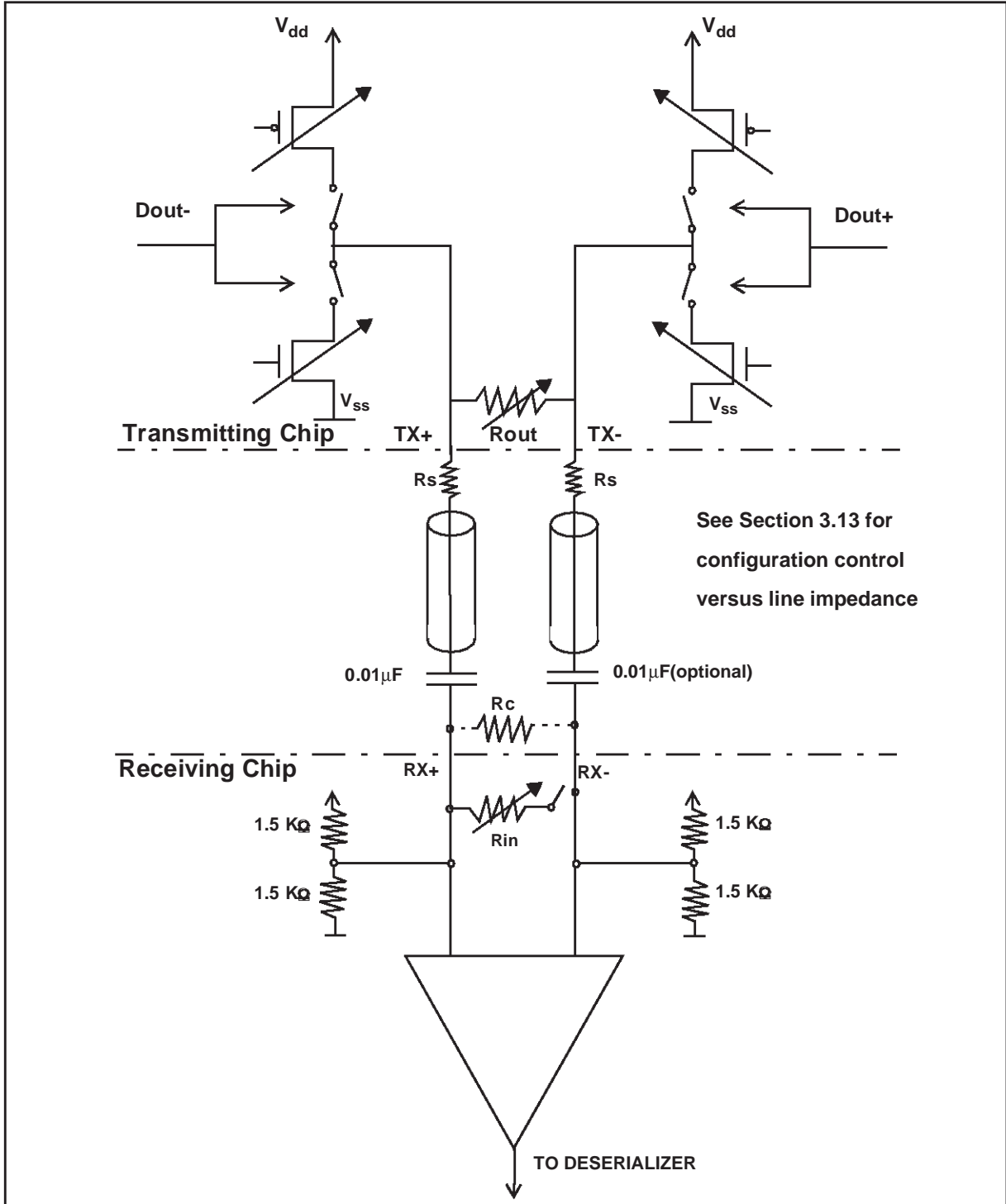

### 3.13 I/O impedance control

The ZC block sets the internal RX+/RX- and the TX+/TX- matching impedance. Table 3.1 details the different settings.

**Table 3.1 ZC block settings**

		ZC+	ZC-	ADD Rs +/-1%	ADD Rc +/-1%
<p><b>Case 1: 50Ω line</b></p>	<p>LINE = 50Ω External Rc</p>	<p>OPEN or V<sub>dd</sub></p>	<p>OPEN or V<sub>dd</sub></p>	<p>0 Ω</p>	<p>100 Ω</p>
<p><b>Case 2: 50Ω line</b></p>	<p>LINE = 50Ω No external Rc Use internal Rc</p>	<p>V<sub>ss</sub></p>	<p>OPEN or V<sub>dd</sub></p>	<p>0 Ω</p>	<p>NONE</p>
<p><b>Case 3: 75Ω line</b></p>	<p>LINE = 75Ω External Rc</p>	<p>OPEN or V<sub>dd</sub></p>	<p>OPEN or V<sub>dd</sub></p>	<p>25 Ω</p>	<p>150 Ω</p>
<p><b>Case 4: 75Ω line</b></p>	<p>LINE = 75Ω External Rc</p>	<p>OPEN or V<sub>dd</sub></p>	<p>V<sub>ss</sub></p>	<p>0 Ω</p>	<p>150 Ω</p>
<p><b>Case 5: 75Ω line</b></p>	<p>LINE = 75Ω No external Rc Use internal Rc</p>	<p>V<sub>ss</sub></p>	<p>V<sub>ss</sub></p>	<p>0 Ω</p>	<p>NONE</p>

Case 3 and 4 are identical applications: Case 3 allows better on board compatibility with other FC parts that request 25Ω series resistors. Exact value of R<sub>out</sub> and R<sub>in</sub> are detailed in Section 5.3: DC characteristics on page 18.

## 3.14 Self-test

The self-test block generates its own internal clock (the frequency of which can be digitally tuned through the JTAG port), and pseudo-random patterns. This data is encoded, serialized, deserialized (through the loop-back test path, or through an external connection between TX+/TX- and RX+/RX-) and decoded. The recovered data is checked; the errors and the number of transmitted bytes are internally counted. The contents of these counters are accessible through the JTAG path. This block is activated by the AT signal.

In normal operation, AT is tied to  $V_{dd}$  and the self-test block is disabled.

During production tests, AT is forced to  $V_{ss}$ , allowing full speed dynamic tests, even at wafer level.

# 4 Serial I/O Electrical Model

This simplified model is given for typical board simulation, within 15% precision. The termination at the receiving end can be either internal or external, following Section 3.13.

**Figure 4.1 Serial I/O electrical schematic diagram**

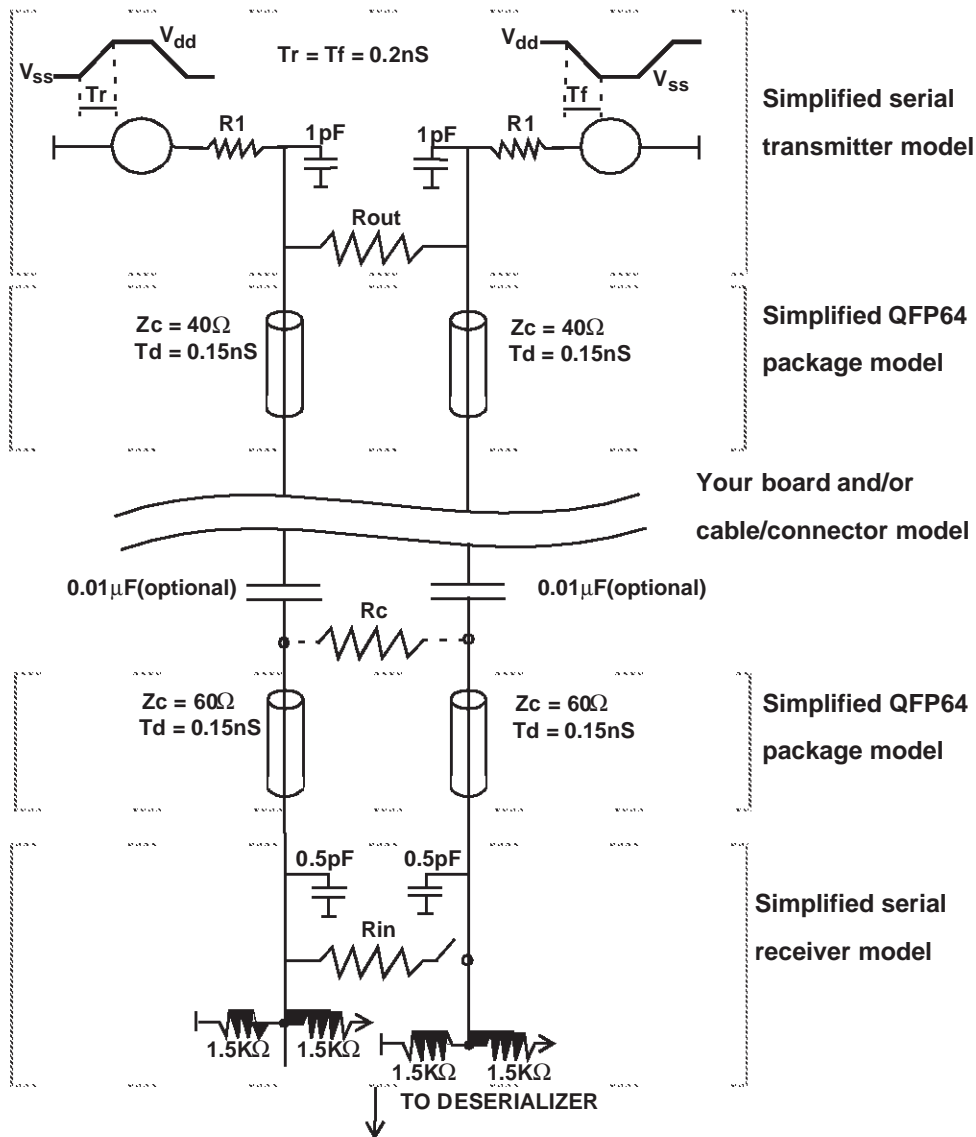

		50Ω CONFIGURATION	75Ω CONFIGURATION
PARAMETER VALUES FOR TYPICAL SIMULATION	R1	100Ω	150Ω
	R <sub>out</sub>	200Ω	300Ω
	R <sub>c</sub>	100Ω if external termination	150Ω if external termination
	R <sub>in</sub>	100Ω if internal termination	150Ω if internal termination



## 5 Electrical Specifications

### 5.1 Absolute maximum ratings

**Table 5.1 Absolute maximum ratings**

Symbol	Parameter	Units	Min	Max
$V_{dd}$	Supply Voltage	V	0	4
$V_{INL}$	Serial signal input low level	V	-0.5	
$V_{INH}$	Serial signal input high level	V		$V_{dd}+0.5$
	ZC+, ZC-	V		$V_{dd}+0.5$
	TTL input signals	V		5.5
$T^{\circ}C_{MAX}$	Maximum assembly temperature (for 10 seconds maximum)	$^{\circ}C$		260
	Storage temperature	$^{\circ}C$	-65	150

*Note* Stresses greater those listed under “Absolute Maximum Ratings” may cause permanent damage to the device. This is a stress rating only and functional operation of the device at these or any other conditions above those indicated in the operational sections of this specification is not guaranteed. Exposure to absolute maximum rating conditions for extended periods may affect device reliability. During overload conditions ( $V_{IN} > V_{dd}$  or  $V_{IN} < V_{SS}$ ) the voltage on pins with respect to ground ( $V_{SS}$ ) must not exceed the values defined by the Absolute Maximum Ratings.

### 5.2 Operating conditions

**Table 5.2 Operating conditions**

Symbol	Parameter	Units	Min	Typ	Max
$V_{dd}$	Supply Voltage	V	3.0	3.3	3.6
	Supply Ripple (DC to 3 GHz)	mV			100
$T_A$	Ambient temperature	$^{\circ}C$	0	25	70
IDD	Supply current @ 25 $^{\circ}C$ , 3.3 volts with parallel outputs loaded by 10pF	mA		150	

## 5.3 DC characteristics

The following values apply to the analog signals TX+, TX-, RX+ and RX-

**Table 5.3 DC characteristics for TX+, TX-, RX+ and RX-**

Symbol	Parameter	Units	Min.	Typ	Max.
$V_{OLS50}$	Serial output low level, terminated differentially by an external 100Ω resistor ( $Z_{c+} = Z_{c-} = \text{"open"}$ )	V	0.90	1.05	1.20
$V_{OHS50}$	Serial output high level, terminated differentially by an external 100Ω resistor ( $Z_{c+} = Z_{c-} = \text{"open"}$ )	V	1.50	1.80	2.10
$V_{OLS75}$	Serial output low level, terminated differentially by an external 150Ω resistor ( $Z_{c+} = \text{"open"}$ - $Z_{c-} = \text{"Vss"}$ )	V	0.90	1.05	1.20
$V_{OHS75}$	Serial output high level, terminated differentially by an external 150Ω resistor ( $Z_{c+} = \text{"open"}$ - $Z_{c-} = \text{"Vss"}$ )	V	1.50	1.80	2.10
$V_{OD50}$	Serial output peak-to-peak differential voltage, terminated differentially by an external 100 Ω resistor ( $Z_{c+} = Z_{c-} = \text{"open"}$ )	V	1.20	1.50	1.80
$V_{OD75}$	Serial output peak-to-peak differential voltage, terminated differentially by an external 150 Ω resistor ( $Z_{c+} = \text{"open"}$ - $Z_{c-} = \text{"Vss"}$ )	V	1.20	1.50	1.80
$R_{OUT50}$	Internal differential output impedance. When 50Ω line ( $Z_{c+} = Z_{c-} = \text{"open"}$ )	Ω	77	100	169
$R_{OUT75}$	Internal differential output impedance. When 75Ω line ( $Z_{c+} = \text{"open"}$ - $Z_{c-} = \text{"Vss"}$ )	Ω	116	150	255
$R_{IN50}$	Internal differential input impedance. When enabled for 50Ω line ( $Z_{c+} = V_{ss}$ / $Z_{c-} = \text{"open"}$ )	Ω	59	100	183
$R_{IN75}$	Internal differential output impedance. When enabled for 75Ω line ( $Z_{c+} = Z_{c-} = V_{ss}$ )	Ω	95	150	265
$V_{ISWS}$	Serial input peak-to-peak differential voltage on RX+ and RX-	V	0.2	-	-

*Note* Values above are given with normal Zc setting. In accordance with Section 3.13, it is still possible to stay with 50Ω internal control and connect the part to 75Ω impedance line by adding 25Ω series resistances.

The following values apply to the logic signals.

**Table 5.4 DC characteristics for logic signals**

Symbol	Parameter	Conditions	Units	Min.	Typ	Max
$V_{IL}$	Input "low" voltage level	$V_{dd}=3.3V$	V	-	-	0.8
$V_{IH}$	Input "high" voltage level	$V_{dd}=3.3V$	V	2.0	-	5.5
VOL	Low level output voltage	$V_{dd}=3.3V$ $I_{ol} = 3mA$	V			0.4
VOH	High level output voltage	$V_{dd}=3.3V$ $I_{oh} = 3mA$	V	2.4		
$I_{IL}$	Input low current	$V_{dd}=\max$ $V_{in}=\text{GND}$	$\mu A$		125	
$I_{IH}$	Input high current	$V_{dd}=\max$ $V_{in}=V_{dd}$	$\mu A$		125	

## 6 Timing Specifications

All AC measurements are made from the reference voltage level of the clock (1.4 volts), to the valid input or output data levels.

### 6.1 Transmit interface timing and latency

Figure 6.1 Transmit interface timing and latency

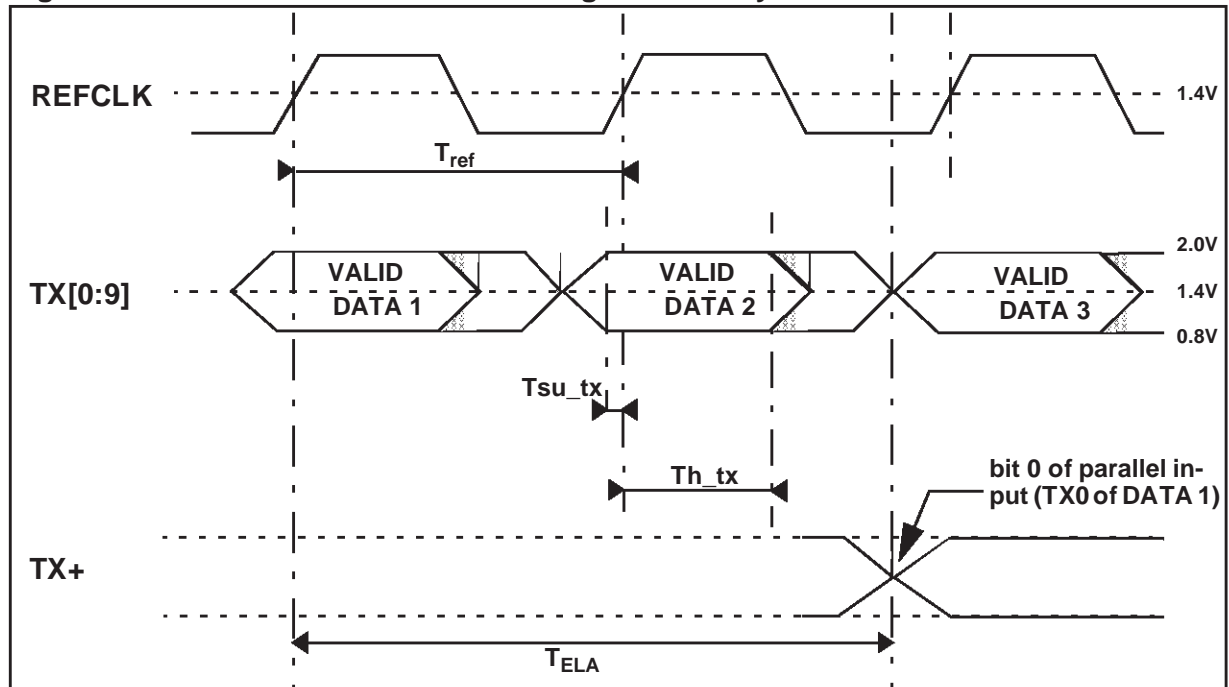

Table 6.1 Transmit interface timing characteristics

Parameter	Description	Min	Typ	Max	Units
$F_{ref}=1/T_{ref}$	Reference clock frequency	100	106.25	110	MHz
$F_{tol}$	Frequency tolerance (dispersion between REFCLK of transmitter and receiver chips)	100	-	+ 100	ppm
$T_r$	REFCLK Clock Rise Time (0.8 to 2V)	0.6	-	2.4	nS
$T_f$	REFCLK Clock Fall Time (0.8 to 2V)	0.6	-	2.4	nS
CLKJIT	REFCLK Jitter			40	pS
DT	REFCLK duty Cycle	40	-	60	%
$T_{su\_tx}$	Data set-up to a rising edge of REFCLK	0	-	-	ns
$T_{h\_tx}$	Data hold after a rising edge of REFCLK	1.5	-	-	ns
$TX-T_r, T_f$	Parallel data rise and fall time (10 pF load)	0.6	-	3	ns
$T_{ELA}$	Data Emission Latency (delay from the initial 10-bit word load to the serial transmission of bit 0)	-	-	1 REFCLK cycle + 8 ns	

## 6.2 Receive interface timing

### 6.2.1 Receive clock timing and latency

Figure 6.2 Receive clock timing

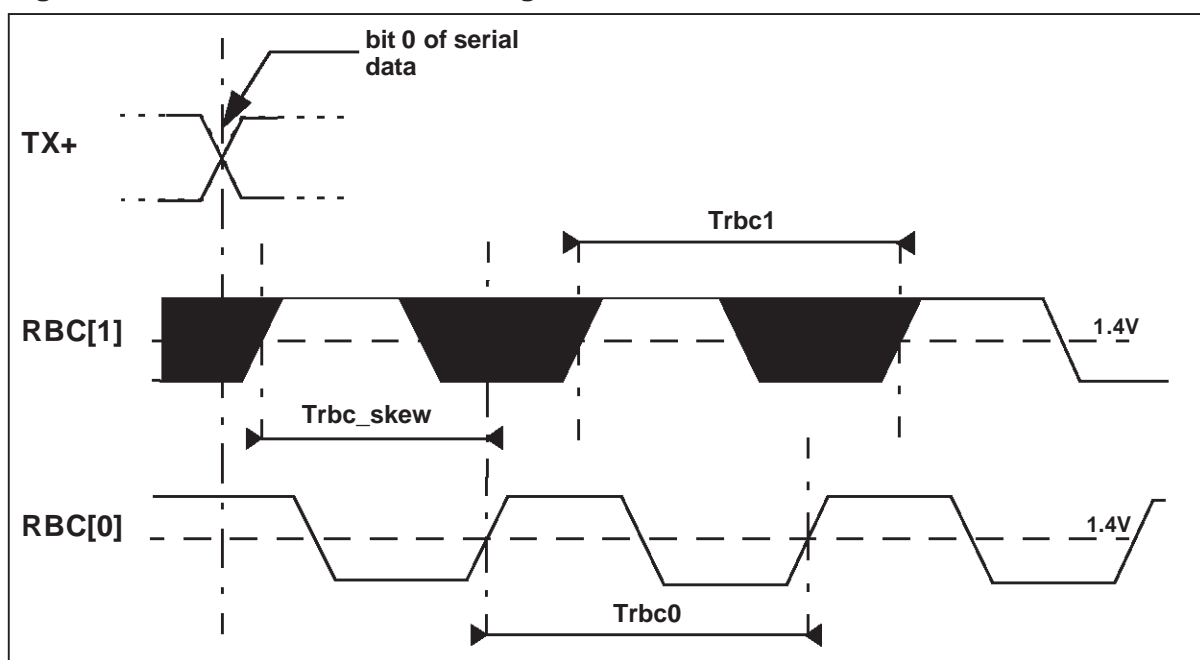

Table 6.2 Receive clock timing characteristics

Parameter	Description	Min	Typ	Max	Units
Trbc0	RBC[0] frequency <sup>1</sup>		53.125		MHz
Trbc1	RBC[1] frequency <sup>1</sup>		53.125		MHz
Trbc_skew	RBC skew	8.9	-	9.9	ns
RBC[0,1] Tr, Tf	Receive clock rise and fall time (10pF load)	-	2.5	-	ns

- Exact frequency of RBC(0,1) depends upon the received data frequency. During byte alignment, the frequency of clocks RBC[0] and RBC[1] may vary by less than 1% of the specified typical value. The clocks are guaranteed to be glitch free.

Figure 6.3 Receive clock latency

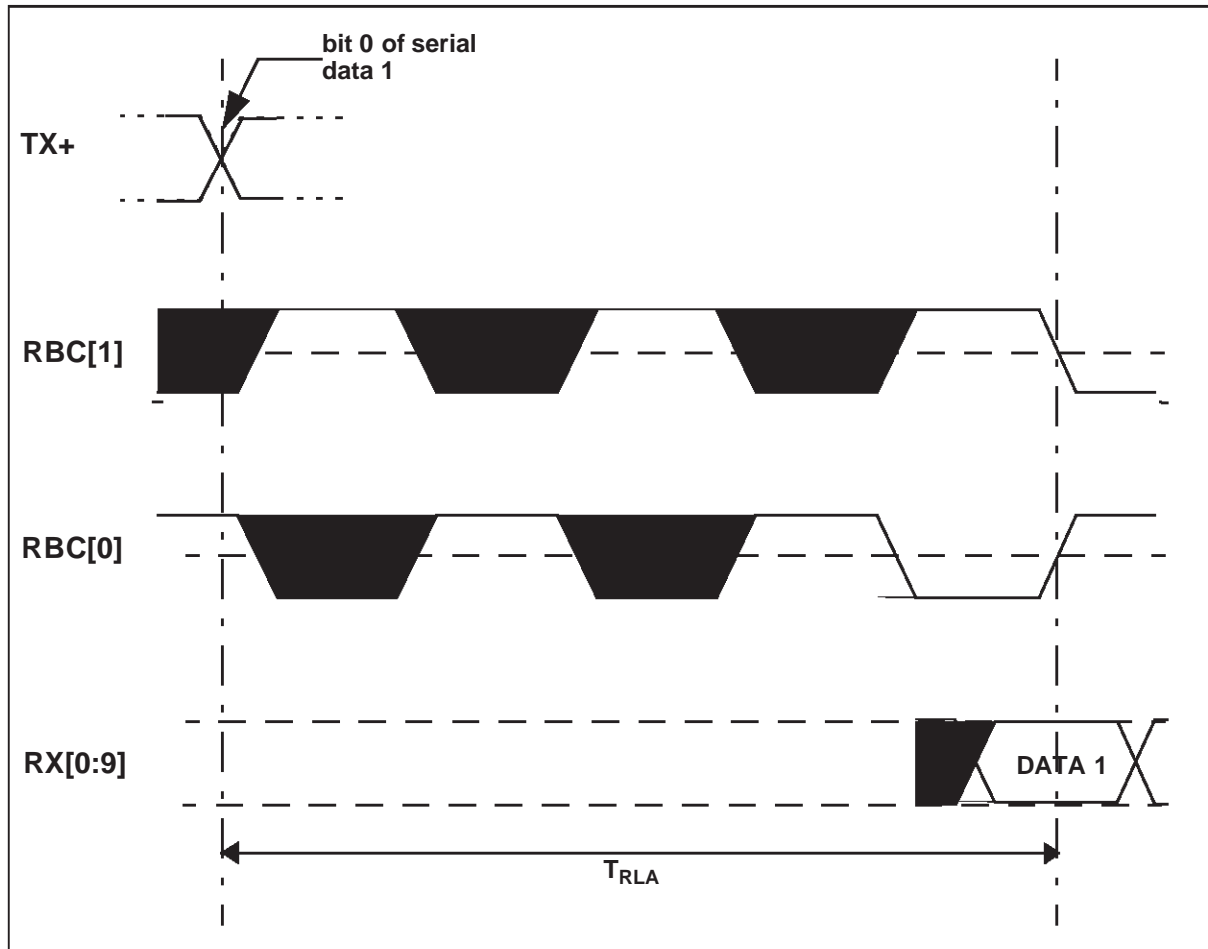

Table 6.3 Receive clock latency characteristics

Parameter	Description	Min	Typ	Max	Units
$T_{RLA}$	Data Reception Latency: Serial (first bit at receiver) to 10-bit parallel output sampled by RBC[0,1].	-	-	5 RBC cycles + 4 ns	ns

### 6.2.2 Receive interface timing

Figure 6.4 Receive interface timing

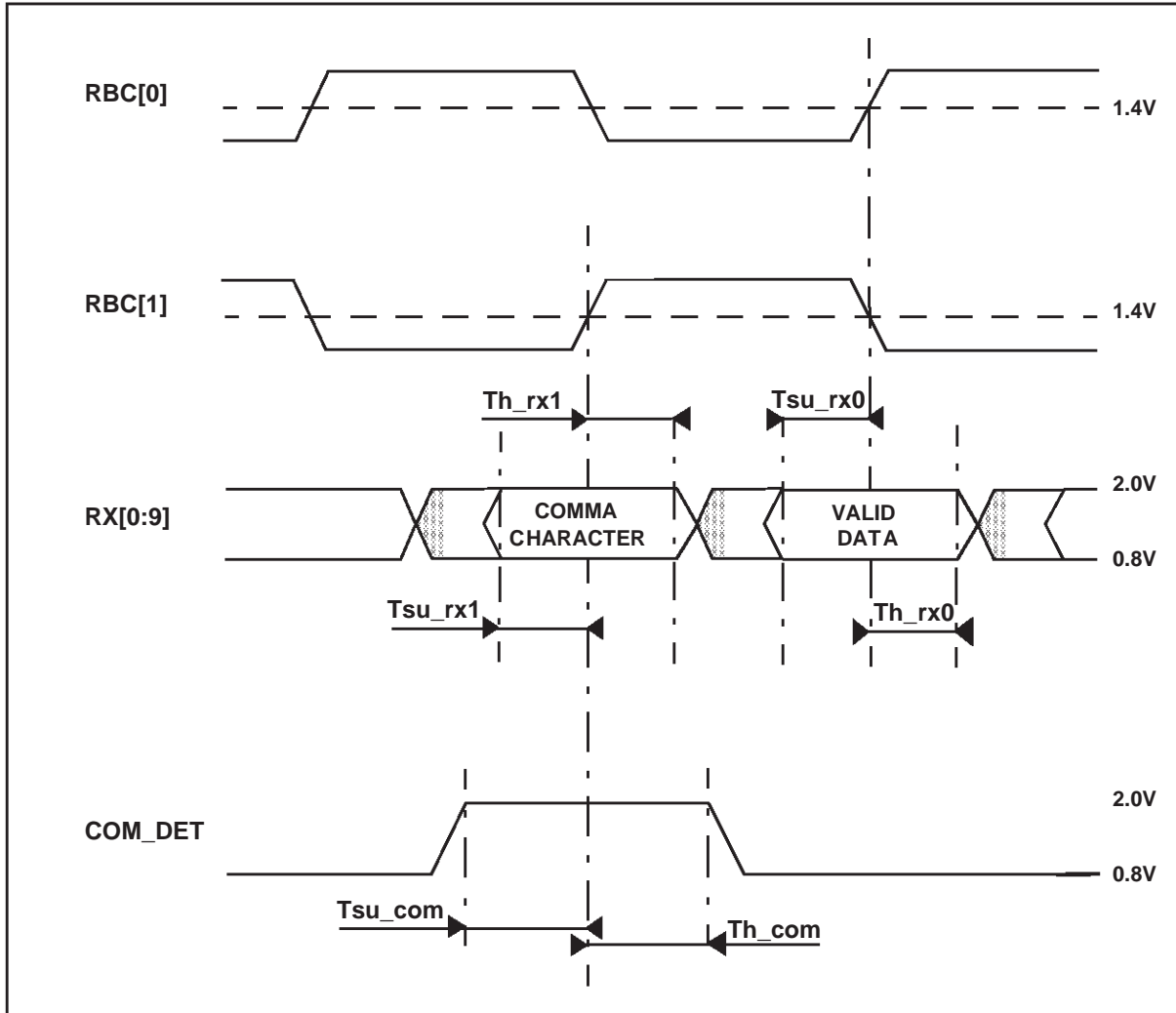

Table 6.4 Receive interface characteristics

Parameter	Description	Min	Typ	Max	Units
$T_{su\_rx1}$	Data valid before a rising edge of RBC[1]	3	-	-	ns
$T_{th\_rx1}$	Data valid after a rising edge of RBC[1]	1.5	-	-	ns
$T_{su\_rx0}$	Data valid before a rising edge of RBC[0]	3	-	-	ns
$T_{th\_rx0}$	Data valid after a rising edge of RBC[0]	1.5	-	-	ns
$T_{su\_com}$	Signal COM_DET valid before a rising edge of RBC[1]	3	-	-	ns

## FC106

---

Parameter	Description	Min	Typ	Max	Units
Th_com	Signal COM_DET valid after a rising edge of RBC[1]	1.5	-	-	ns
COM_DET Tr, Tf	COM_DET rise and fall time (10pF load)		2.5		ns
RX[0:9]	RX(n) rise and fall time (10pF load)		2.5		ns

## 6.3 Serial Input/output AC characteristics

Table 6.5 Serial I/O AC characteristics

Parameter	Description	Min	Typ	Max	Units
t <sub>RS</sub>	Serial output rise time, terminated by the FC106 receiver (20%-80%)	-	200	-	ps
t <sub>FS</sub>	Serial output fall time, terminated by the FC106 receiver (20%-80%)	-	200	-	ps
t <sub>SK</sub>	Differential skew between TX+ and TX-, terminated by the FC106 receiver	-	-	25	ps



## 7 FC106 Pin Description

### 7.1 Pin summary

Table 7.1 Pin summary

Pin	Level	Description
AT*	CMOS	This signal places the chip in a self-test mode when tied low. It should be tied to $V_{dd}$ in any other state of the chip, as specified in the 10-Bit Interface Specification standard.
COM_DET	CMOS	COM_DET is an indication that the data byte (byte 0 of word 0) associated with the current RBC[1] contains a valid comma symbol.
EN_CDET	CMOS	EN_CDET enables the chip to perform the byte alignment function on comma symbols. When EN_CDET is high, the byte alignment function is operational. When EN_CDET is low, the current byte alignment is maintained.
EWRAP	CMOS	EWRAP causes the chip to internally loop serialized transmit data to the deserializer. EWRAP is active on high level.
RBC[0]	CMOS	RBC[0] is the 53.125 MHz receive byte clock that the protocol device will use to register the bytes 1 and 3 of the received data word. This clock may be stretched during byte alignment (never slivered or truncated).
RBC[1]	CMOS	RBC[1] is the 53.125 MHz receive byte clock that the protocol device will use to register the bytes 0 and 2 of the received data word. RBC[1] is 180° out of phase with RBC[0]. This clock may be stretched during byte alignment (never slivered or truncated).
REFCLK	CMOS	REFCLK is the 106.25 MHz reference clock. The frequency tolerance for this clock should meet ANSI X3.230-1994 Fibre Channel FC-PH specifications for a Fibre Channel use. See Section 6.1: <i>Transmit interface timing and latency</i> on page 20.
RX+, RX-	Special	RX+ and RX- are the differential inputs for serialized data on the receiver.
RX[0:9]	CMOS	RX[0:9] is the 10-bit parallel received data presented by the chip to the upper layer for further processing. The received data byte 0 containing the comma symbol will be byte aligned to RBC[1], i.e. byte 0 is in phase with RBC[1]. The order of reception on the serial input is RX[0] first, followed by RX[1] through to RX[9].
TCK*, TRSTN*, TMS*, TDI*, TDO*	CMOS	These signals are compliant to the JTAG specification.
TEST ENABLE*	CMOS	Used during ATPG test, connected at $V_{ss}$ in normal operation.
TX+, TX-	Special	TX+ and TX- are the differential outputs for serialized data on the transmitter.

Pin	Level	Description
TX[0:9]	CMOS	TX[0:9] is the 10-bit parallel transmit data presented to the chip for serialization and transmission onto the media. The order of transmission is TX[0] through to TX[9].
ZC+ <sup>1</sup> , ZC- <sup>*</sup>	CMOS	These pins are used to control the input and output impedance in accordance with the configuration outlined in Section 3.13: <i>I/O impedance control</i> on page 14.

1. indicates signals that are not included in the Fibre Channel 10-Bit Interface Specification.

## 7.2 Pin functions

Table 7.2 Pin functions

Pin Name	Pin #	I/O	pull up/down	Description in standard running conditions	TEST pins
V <sub>ss</sub>	1	-	-	Ground Pin	
TX[0]	2	I	pd	Bit 0 of parallel transmit data (first bit sent)	
TX[1]	3	I	pd	Bit 1 of parallel transmit data	
TX[2]	4	I	pd	Bit 2 of parallel transmit data	
V <sub>dd</sub>	5	-	-	Power Pin	
TX[3]	6	I	pd	Bit 3 of parallel transmit data	
TX[4]	7	I	pd	Bit 4 of parallel transmit data	
TX[5]	8	I	pd	Bit 5 of parallel transmit data	
TX[6]	9	I	pd	Bit 6 of parallel transmit data	
V <sub>dd</sub>	10	-	-	Power Pin	
TX[7]	11	I	pd	Bit 7 of parallel transmit data	
TX[8]	12	I	pd	Bit 8 of parallel transmit data	
TX[9]	13	I	pd	Bit 9 of parallel transmit data (last bit sent)	
V <sub>ss</sub>	14	-	-	Ground Pin	
V <sub>ss</sub> /RS	15	(I)	pd	Must be tied to GND during normal operation. During power up, an internal circuit will automatically reset the chip. Nevertheless RS allows a forced reset (when high), during normal operation.	External reset
NC/TDI	16	(I)	pd	Not connected	JTAG scan in
NC/TCK	17	(I)	pd	Not connected	Test clock pin for JTAG

## FC106

Pin Name	Pin #	I/O	pull up/down	Description in standard running conditions	TEST pins
V <sub>dd</sub> /TRSTN	18	(I)	pu	Must be tied to V <sub>dd</sub> .	Reset pin for JTAG
EWRAP	19	I	pd	When tied to V <sub>dd</sub> , causes the chip to internally loop serialized transmit data to the deserializer.	
V <sub>dd</sub> /TMS	20	(I)	pu	Must be tied to V <sub>dd</sub> .	Test mode select for JTAG
V <sub>ss</sub>	21	-	-	Ground Pin	
REFCLK	22	I	pd	Reference clock frequency 106.25 MHz	
V <sub>dd</sub>	23	I	-	Power Pin	
EN_CDET	24	I	pu	Enables the chip to perform the byte alignment function when HIGH.	
TEST ENABLE	25	I	pd	Must be tied to GND.	Tie to V <sub>dd</sub> for AT PG
NC/TDO	26	(O)	-	Not connected	JTAG scan out
NC	27	-	-	Not connected	
V <sub>dd</sub> /AT	28	(I)	pu	Must be tied to V <sub>dd</sub> .	Places the chip in auto test mode when LOW.
V <sub>dd</sub>	29	-	-	Power Pin	
RBC[1]	30	O	-	Receive byte clock used by the protocol to register byte 0 and 2 of the receive parallel data.	
RBC[0]	31	O	-	Receive byte clock used by the protocol to register byte 1 and 3 of the receive parallel data.	
V <sub>ss</sub>	32	-	-	Ground Pin	
V <sub>ss</sub>	33	-	-	Ground Pin	
RX[9]	34	O	-	Bit 9 of parallel receive data (last bit received)	
RX[8]	35	O	-	Bit 8 of parallel receive data	
RX[7]	36	O	-	Bit 7 of parallel receive data	
V <sub>dd</sub>	37	-	-	Power Pin	
RX[6]	38	O	-	Bit 6 of parallel receive data	
RX[5]	39	O	-	Bit 5 of parallel receive data	
RX[4]	40	O	-	Bit 4 of parallel receive data	
RX[3]	41	O	-	Bit 3 of parallel receive data	
V <sub>dd</sub>	42	-	-	Power Pin	

## FC106

Pin Name	Pin #	I/O	pull up/ down	Description in standard running conditions	TEST pins
RX[2]	43	O	-	Bit 2 of parallel receive data	
RX[1]	44	O	-	Bit 1 of parallel receive data	
RX[0]	45	O	-	Bit 0 of parallel receive data (first bit received).	
V <sub>ss</sub>	46	-	-	Ground Pin	
COM_DET	47	O	-	Goes high when detecting a comma symbol. Data byte associated with RBC[1] contains valid comma symbol.	
ZC-	48	1	pu	Used for impedance adaptation (see Section 3.13)	
ZC+	49	1	pu	Used for impedance adaptation (see Section 3.13)	
V <sub>dd</sub>	50	-	-	Power Pin	
V <sub>ss</sub>	51	-	-	Ground Pin	
RX-	52	I	-	One of the differential inputs for serialized data on the receiver. Serial input frequency must be $1.0625 \pm 0.0001$ Gb/s.	
V <sub>dd</sub>	53	-	-	Power Pin	
RX+	54	I	-	One of the differential inputs for serialized data on the receiver. Serial input frequency must be $1.0625 \pm 0.0001$ Gb/s.	
V <sub>dd</sub>	55	-	-	Power Pin	
V <sub>ss</sub>	56	-	-	Ground Pin	
V <sub>dd</sub>	57	-	-	Power Pin	
V <sub>ss</sub>	58	-	-	Ground Pin	
V <sub>dd</sub>	59	-	-	Power Pin	
V <sub>dd</sub>	60	-	-	Power Pin	
TX-	61	O	-	One of the differential outputs for serialized data on the transmitter. Serial output rate depends on REFCLK.	
TX+	62	O	-	One of the differential outputs for serialized data on the transmitter. Serial output rate depends on REFCLK.	
V <sub>dd</sub>	63	-	-	Power Pin	
NC	64	-	-	Not connected	

# 8 Package Specifications

The FC106 is available in two sizes of 64-pin plastic quad flat-pack: the FC106/14 measures 14x14 mm and the FC106/10 measures 10x10 mm.

## 8.1 FC106 64-pin PQFP pinout

Figure 8.1 Pinout for 64-pin PQFP (both 14x14 mm and 10x10 mm sizes)

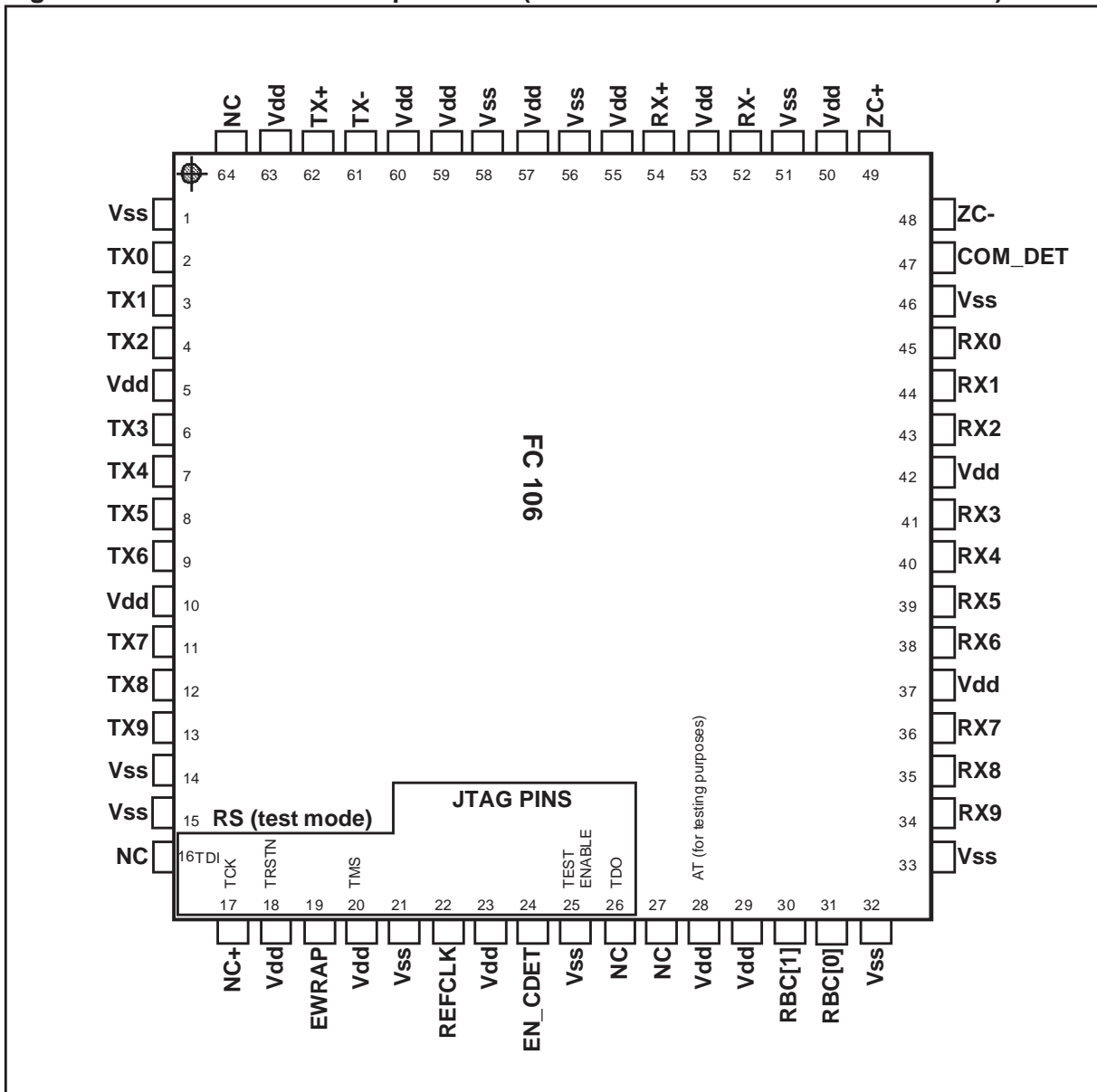

## 8.2 FC106 64-pin Quad Flat-pack package dimensions

### 8.2.1 FC106/14: 14x14 mm package dimensions

Figure 8.2 Data for 64-pin 14x14 mm PQFP

DIM	mm			inch		
	MIN.	TYP.	MAX.	MIN.	TYP.	MAX.
A	-	-	2.35	-	-	0.093
A1	-	-	0.25	-	-	0.010
A2	1.95	2.00	2.10	0.077	0.079	0.083
b	0.30	0.35	0.40	0.012	0.014	0.016
c	-	-	0.17	-	-	0.067
D	16.95	17.20	17.45	0.667	0.677	0.687
D1	13.90	14.00	14.10	0.547	0.551	0.555
D2	-	12.00	-	-	0.472	-
e	-	0.80	-	-	0.031	-
E	16.95	17.20	17.45	0.667	0.677	0.687
E1	13.90	14.00	14.10	0.547	0.550	0.555
E2	-	12.00	-	-	0.472	-
$\theta$	0°-7°					
L	0.78	0.88	1.03	0.031	0.035	0.041

PQFP64

Body: 14 x 14 x 2.0 mm

Footprint: 3.20 mm

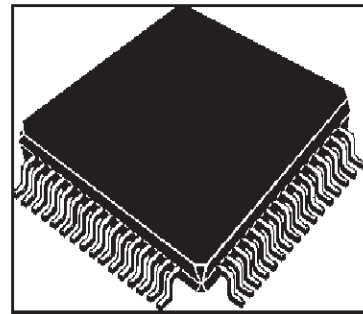

Thermal resistance = 45°C/W (still air)

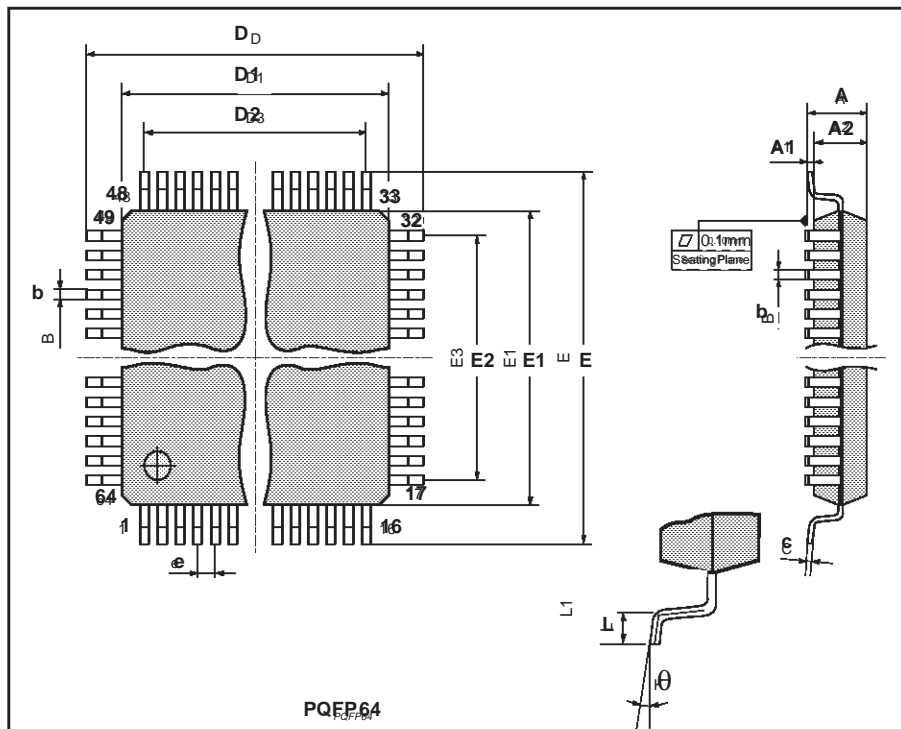

### 8.2.2 FC106/10: 10x10 mm package dimensions

Figure 8.3 Data for 64-pin 10x10 mm PQFP

DIM	mm			inch		
	MIN.	TYP.	MAX.	MIN.	TYP.	MAX.
A	-	-	2.45	-	-	0.097
A1	0.25	-	0.50	0.010	-	0.020
A2	1.95	2.00	2.10	0.077	0.079	0.083
b	0.17	0.22	0.27	0.007	0.009	0.011
c	-	-	0.17	-	-	0.067
D	12.95	13.20	13.45	0.510	0.520	0.530
D1	9.90	10.00	10.10	0.390	0.394	0.398
D2	-	7.50	-	-	0.295	-
e	-	0.50	-	-	0.020	-
E	12.95	13.20	13.45	0.510	0.520	0.530
E1	9.90	10.00	10.10	0.390	0.394	0.398
E2	-	7.50	-	-	0.295	-
$\theta$	0°-7°					
L	0.78	0.88	1.03	0.031	0.035	0.041

PQFP64

Body: 10 x 10 x 2.0 mm

Footprint: 3.20mm

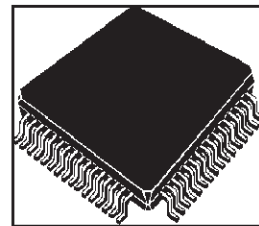

Thermal resistance = 45°C/W (still air)

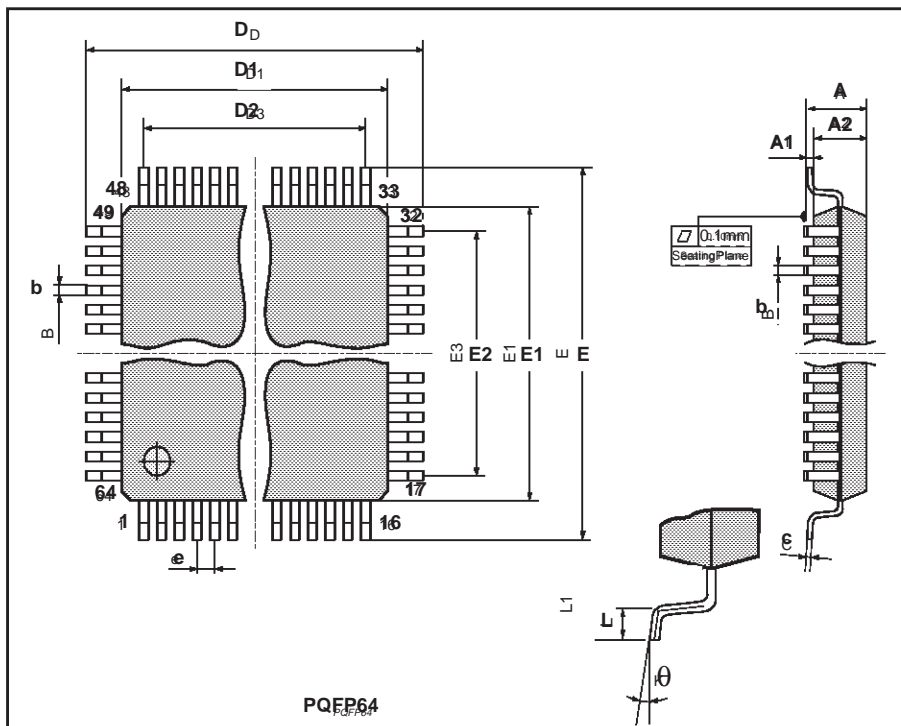

Information furnished is believed to be accurate and reliable. However, STMicroelectronics assumes no responsibility for the consequences of use of such information nor for any infringement of patents or other rights of third parties which may result from its use. No license is granted by implication or otherwise under any patent or patent rights of STMicroelectronics. Specifications mentioned in this publication are subject to change without notice. This publication supersedes and replaces all information previously supplied. STMicroelectronics products are not authorized for use as critical components in life support devices or systems without express written approval of STMicroelectronics. This circuit uses patents licensed by BULL S.A..

The ST logo is a trademark of STMicroelectronics.

© 1998 STMicroelectronics - All Rights Reserved

STMicroelectronics GROUP OF COMPANIES

Australia - Brazil - Canada - China - France - Germany - Italy - Japan - Korea - Malaysia - Malta - Mexico - Morocco -  
The Netherlands - Singapore - Spain - Sweden - Switzerland - Taiwan - United Kingdom - U.S.A.