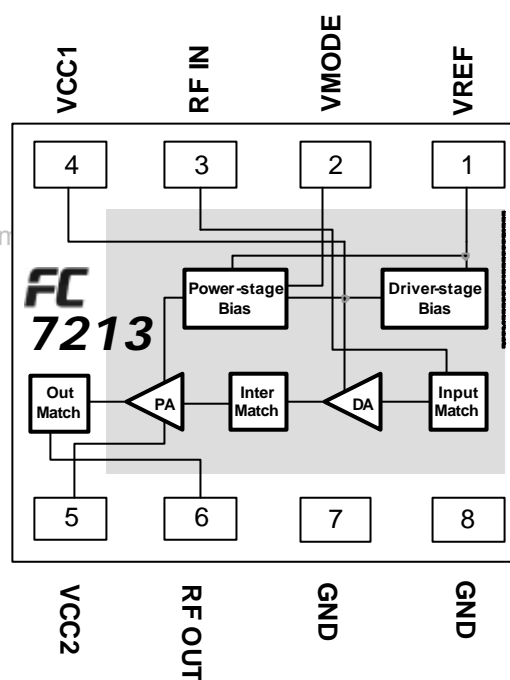

**DESCRIPTION**

FC7213 is a high-power, high-efficiency power amplifier module for US-PCS CDMA wireless handsets. It consists of a two-stage amplifier, 50-ohm input/output matching networks, and additional bias control circuitry. FC7213 provides excellent performance up to 28-dBm output power only with single-mode operation. This single-mode operation in FC7213 eliminates the need for mode change between low-power and high-power/high-gain modes. This advantage enables any handsets that use FC7213 to carry out one step calibration in any handsets with low idle current. FC7213 is assembled in a 3-mm x 3-mm leadless package without any passive components in it. This package provides excellent electrical stability and low thermal resistance. FC7213 is manufactured with an advanced InGaP HBT MMIC process.

**FEATURES**

- Small surface mounting package (3x3x1.32mm)
- Operating frequency: 1850~1910MHz
- Single-mode operation up to 28dBm
- Very low quiescent current: 34mA
- Optimized for a 50-Ω system
- Lead-free package
- No passive component in package
- Low leakage current in shutdown mode: < 1uA

**FUNCTIONAL BLOCK DIAGRAM****(TOP VIEW)****APPLICATIONS**

- US PCS CDMA Wireless Handsets

**REVISION HISTORY**

- **Preliminary** version datasheet release: October 5, 2004
- **Preliminary** version datasheet release: December 30, 2004
- **Preliminary** version datasheet release: February 28, 2005

For latest specifications, technical questions and additional product information, visit website or e-mail

FCI Inc.  
 2nd Fl. Korea First Bank B/D,  
 6-8 Sunae-Dong Bundang-Gu,  
 Sungnam City, Gyunggi-do,  
 463-020, KOREA

Website: <http://www.fci.co.kr>  
 E-mail : [info@fci.co.kr](mailto:info@fci.co.kr)  
 Phone : 82-31-711-6444  
 Fax: 82-31-714-6576

**ABSOLUTE MAXIMUM RATINGS**

Parameter	Unit	Min	Max
Supply Voltage (Vcc)	V	-	+5
Mode Control Voltage (VMODE)	V	-	+3.2
Reference Voltage (VREF)	V	-	+3.2
RF Input Power (RF IN)	dBm	-	+7
Storage Temperature (Tstg)	°C	-55	+125

*Stress in excess of the absolute ratings may cause permanent damage. Functional operation is not implied under these conditions. Exposure to absolute ratings for extended periods of time may adversely affect reliability.*

**RECOMMENDED OPERATING CONDITIONS**

Parameter	Unit	Min	Typ	Max	Note
Operating Frequency(f)	MHz	1850	1880	1910	
Supply Voltage(Vcc)	V	+3.2	+3.4	+4.2	
Reference Voltage (VREF)	V	+2.7 0	+2.8 0	+2.9 +0.5	PA "on" PA "shut down"
Mode Control Voltage(VMODE)	V	+2.6 0	+2.8 0	+3.0 0.5	Low Mode High Mode
RF Output Power (RF OUT)	dBm	- -	+28	- -	Vcc=+3.4V

*The device may be operated safely over these conditions.*

**BIAS CONTROL**

Power Mode		VREF	VMODE	Range
CDMA Mode	Low Mode	2.8V	2.6~3V	<-15dBm
	High Mode	2.8V	0~0.5V	-15 ~ 28dBm
Shut Down		0.0V	0.0V	-

**ELECTRICAL CHARACTERISTICS**

(Test Condition : Vcc = 3.4V, Vref = 2.8V, T = +25 and Frequency = 1880MHz)

Parameter		Unit	Specification			Note
			Min	Typ	Max	
High Mode (Vmode=0V)	Gain	dB	-	29.5 28	-	Pout=28dBm Pout=16dBm
	Adjacent Channel Power at $\pm 1.25$ MHz offset*	dBc	-	-50 -50	-	Pout=28dBm Pout=16dBm
	Adjacent Channel Power At $\pm 2.25$ MHz offset*	dBc	-	-58 -60	-	Pout=28dBm Pout=16dBm
	Total Supply Current	mA	-	480 125	-	Pout=28dBm Pout=16dBm
	Power-Added Efficiency	%	-	38.7 9.4	-	Pout=28dBm Pout=16dBm
	Quiescent Current (Icq)	mA	-	34	-	
** Low Mode (Vmode=2.8V)	Gain	dB	-	16	-	Pout=<-15dBm
	Adjacent Channel Power at $\pm 1.25$ MHz offset*	dBc	-	<-50	-	Pout=<-15dBm
	Adjacent Channel Power At $\pm 2.25$ MHz offset*	dBc	-	<-60	-	Pout=<-15dBm
	Quiescent Current (Icq)	mA	-	16	-	
Reference Current	mA	-	2.9	-	Through Vref Pin(2.8V)	
Mode Control Current	mA	-	0.2	-	Through Vmode Pin	
Leakage Current	uA	-	1	-	Vcc=3.4V, Vref=0V, Vmode=0V	
Noise in Receive Band	DBm/Hz	-	-136	-	1930MHz to 1990MHz	
Harmonics 2fo Harmonics 3fo	dBc	-	-30 -30	-	Pout<28dBm	
Input Impedance	VSWR	-	1.5:1	-		
Ruggedness-No damage	VSWR	-	10:1	-	Pout<28dBm, all phases	

\*Test Condition; Primary Channel BW=1.23 MHz, Adjacent Channel BW=30 kHz

\*\*In the case that the transmitter has a wide dynamic range, it will be enough to use high mode only without switching operation.

**PIN DESCRIPTION**

Pin	Name	Description	Pin	Name	Description
1	VREF	Reference Voltage	5	VCC2	Supply Voltage
2	VMODE	Mode Control Voltage	6	RF OUT	RF Output
3	RF IN	RF Input	7	GND	Ground
4	VCC1	Supply Voltage	8	GND	Ground

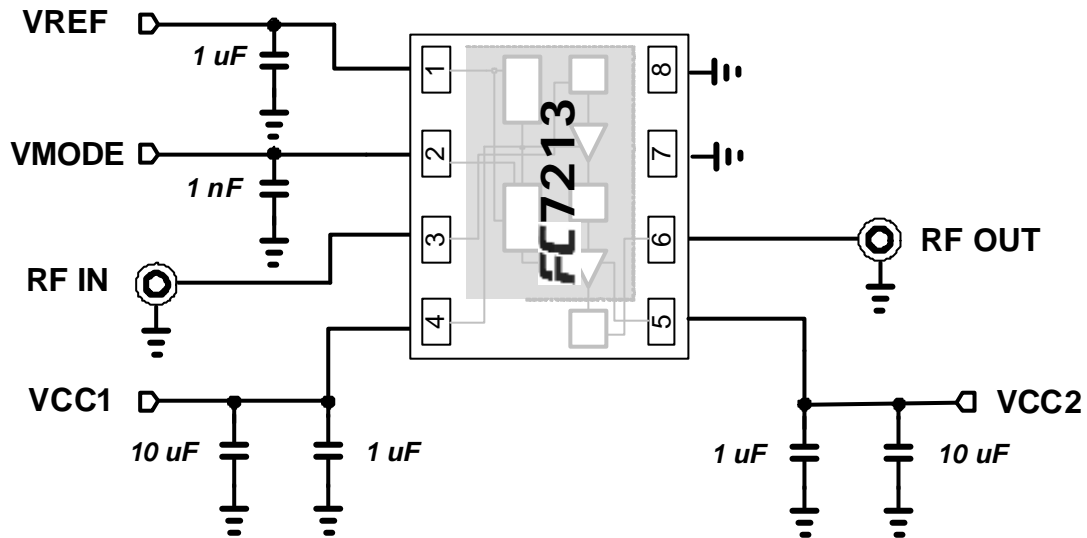
**EVALUATION BOARD SCHEMATIC (TOP VIEW)**

**PACKAGE OUTLINE AND DIMENSIONS**

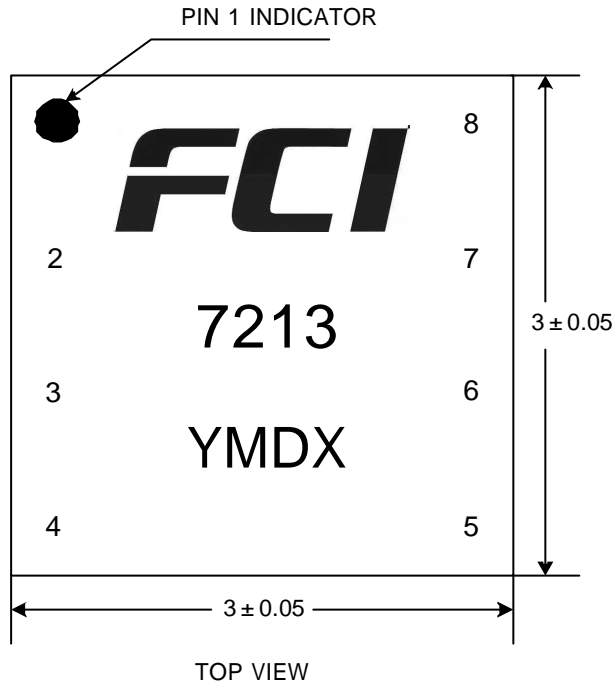

Line	Device Marking Description
1	FCI's Company Name
2	7213 = Product Name
3	YMDX LOT Code Y = Year code M = Month code D = Day code X = Manufacture code
	Pin 1 Identifier

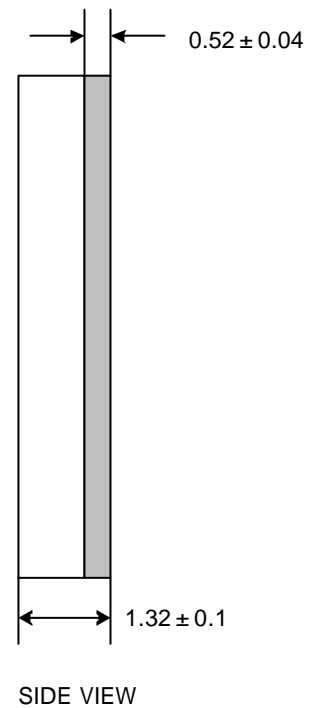
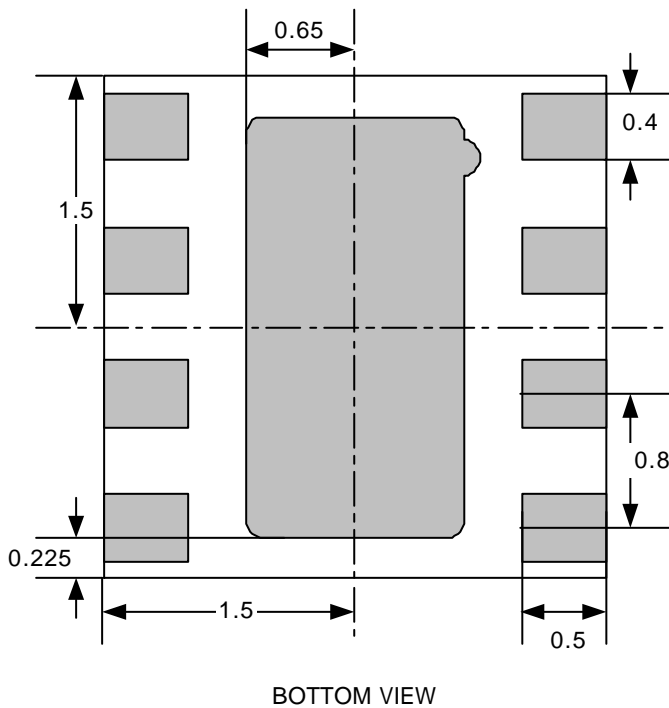

All dimensions are in millimeters